

Description: **ROBINHOOD WALL CANOPY**
Model Number: **RWH3CL6SS, RWH3CL9SS**

Typical design

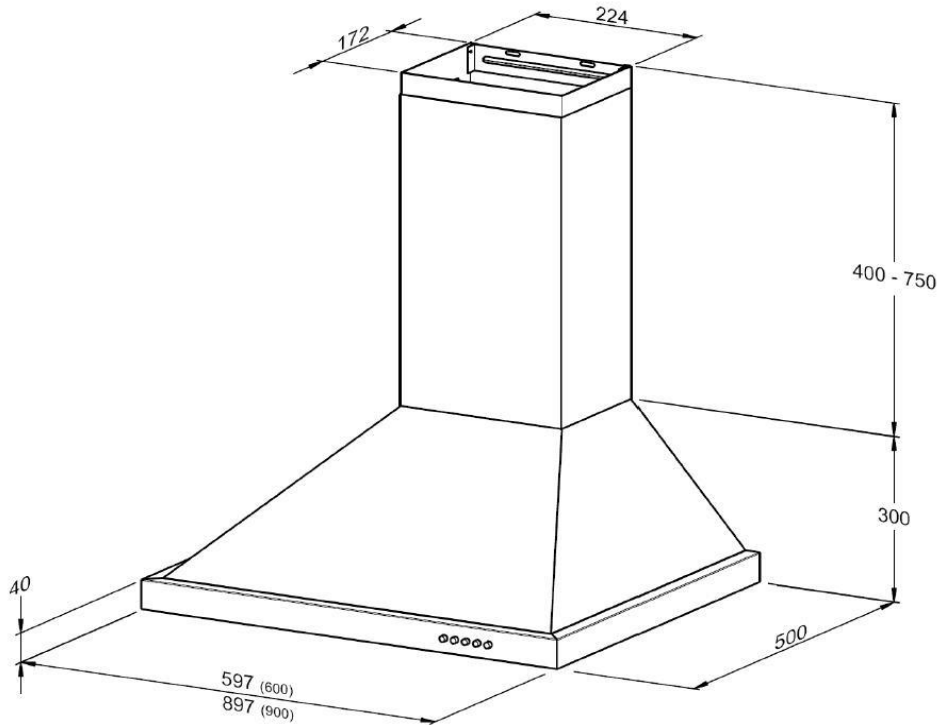

Features and benefits

High performance extraction fan

High performance extraction fan rapidly removes steam, smoke and cooking smells from your kitchen. Three-speed switch lets you select the fan strength you need – half strength for steamed vegetables; full strength for stir fries.

LED lamps

2x3 watt LED lamps illuminate the entire cooking surface. GU10 type lamps are quick and easy to replace.

Multi-layered micromesh filters

Multi-layered micromesh filters effectively trap grease. They're simple to remove and are easily maintained with a regular clean in the dishwasher.

Rectilinear design

Simple styling makes cleaning easy. High quality stainless steel and the fingertip controls are easy to clean with a damp cloth.

Thermal overload switch

Thermal overload function that senses extreme heat and disconnects power to the motor temporarily. If you have a cooking disaster, and something catches fire, the rangehood automatically switches off to prevent flames and sparks being sucked into the ducting or ceiling.

Recirculation option

In situations where ducting isn't possible, your rangehood can be fitted with charcoal filters that effectively cleanse the air before returning it to the kitchen.

Specifications

Technical data:

- 3 speed centrifugal motor: 330watts, Class F, 10uF/450V
- 2 x 3 Watt LED GU10 type lamps
- Maximum power consumption: 370 watts
- Gauge of steel: 0.6 mm
- Type of steel: 430 stainless steel
- Finish of steel : brush number 4
- 240 Volt. 50 Hertz. 370 Watt Max.
- Tested to EMC CISPR14:2001
- Electrical approval: AS/NZS 3350.2.31.2001
- Performance tested to IEC61591 (replaces AS2682-1984)
- Filter specifications: Three layered micro mesh
- Length of power cord: 1500mm
- Ducting outlet: 150mm diameter round outlet – top ducting
- Recirculation option through top duct outlet

Gross weight: RWH3CL6SS 12.2kg. RWH3CL9SS 15.4kg

Carton volume: 0.132m³ (600 model), 0.194m³ (900 model)

Carton dimensions : 650 x 370 x 550mm (600 model), 955 x 370 x 550mm (900 model)

Rangehood dimensions: 597 x 500 x 300mm (600 model), 897 x 500 x 300mm (900 model)

Performance data:

○ RWH3CL6SS

○ RWH3CL9SS

Fan speed 1	450m ³ /hr	Fan speed 1	450m ³ /hr
Fan speed 2	640m ³ /hr	Fan speed 2	640m ³ /hr
Fan speed 3	850m ³ /hr	Fan speed 3	850m ³ /hr
Noise speed 1	56.3dB	Noise speed 1	56.3dB
Noise speed 2	65.3dB	Noise speed 2	65.3dB
Noise speed 3	70.4dB	Noise speed 3	70.4dB

New Zealand

Monaco Corporation Ltd
Telephone: (09) 415 6000
Facsimile: (09) 415 7400
Email: enquiries@robinhood.co.nz
www.robinhood.co.nz

Australia

Shiro Australia Pty Ltd
ABN 28 002 386 129
Telephone: 1800 648 556
Facsimile: 1800 628 577
Email: enquiries@robinhood.com.au
www.robinhood.com.au

