

Description

ROBINHOOD ATALA POWERPACK 52CM LED PANEL LIGHT
RPL3CL52BK



Key Features

Motor Type

DC Motor

Max Motor Performance

850 m³/hr

Control Type

Touch & Gesture Control

Lighting

1 x 15W LED Panel

Warranty

5 years warranty on parts & labour from the date of purchase
(For domestic use only)

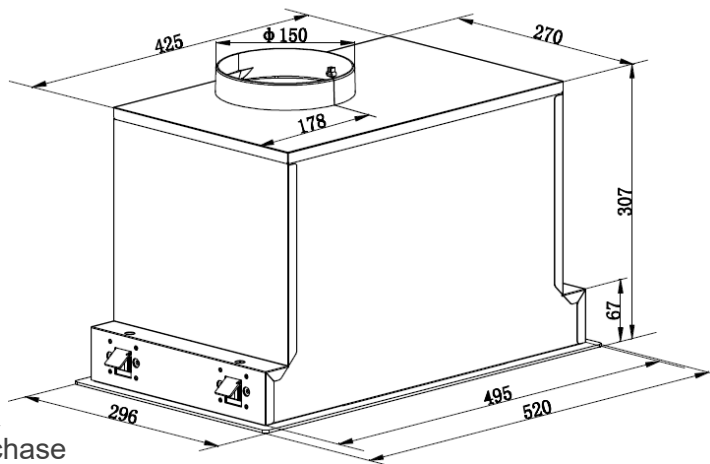

Dated 22/03/2024

Specifications

Voltage	220~240v
Frequency	50~60Hz
Motor Type/ Power	DC motor/ 145W
Energy Efficiency Index (EEI)	A++
Max Motor Performance	850 m ³ /hr
Power Levels	3
Control Type	Touch & gesture control
Light/ Colour Temperature	1 x 15W LED panel
Filter	1 x 3 layers aluminium filter
Optional Charcoal Filter	Yes. RHCF115
Ducting Outlet	Ø150mm
Power Cord Length	1.5m
Product Dimensions (WxDxH)	520 x 296 x 307mm
Carton Dimensions (WxDxH)	565 x 410 x 340mm
Cut-out Size (WxD)	500 x 275mm
Gross/ Net Weight	11.5/ 9.5Kg

Power Level	Air Flow & Noise Level*	
	Air Flow (m ³ /hr) (IEC 61591)	Noise Level (dB) (IEC 60704-2-13)
1	220	38
2	600	54
3	825	63

*Air Flow & Noise Level testing is conducted in a controlled lab environment as per the IEC standards.