

Description: **ROBINHOOD POWERPACK**
Model Number: **RPA3CI6SS/WH, RPA3CI9SS/WH**

Typical design

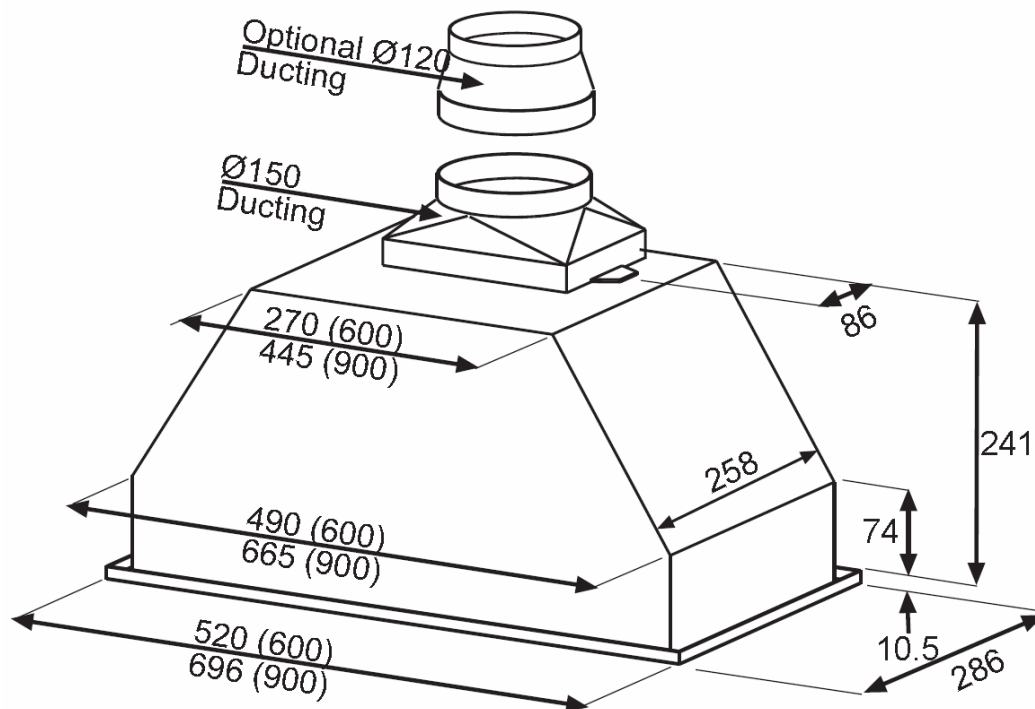

All dimensions in mm

Features and benefits

High performance extraction motor

High performance extraction motor rapidly removes steam, smoke and cooking smells from your kitchen. Three-speed switch lets you select the fan strength you ever need. With significant improved performance of the new motor, unit has top performance of 551 m³/hr air movement but only 290 Watt maximum power consumption. Saving your energy while delivering second to none performance to your kitchen environment.

Incandescent lamps

40 watt incandescent lamps illuminate the entire cooking surface. Lamps are quick and easy to replace.

Multi-layered micromesh filters

Multi-layered micromesh filters effectively trap grease. They're simple to remove and are easily maintained with a regular clean in the dishwasher.

Rectilinear design

Simple styling makes cleaning easy. High quality stainless or powder coated steel and the fingertip controls are easy to clean with a damp cloth.

Thermal overload switch

Thermal overload function that senses extreme heat and disconnects power to the motor. If you have a cooking disaster, and something catches fire, the rangehood automatically switches off to prevent flames and sparks being sucked into the ducting or ceiling.

Recirculation option

In situations where ducting isn't possible, your rangehood can be fitted with charcoal filters that effectively cleanse the air before returning it to the kitchen.

Specifications

Technical data:

- 3 speed centrifugal motor
- 2 x 40 Watt incandescent lamps
- Air movement: 551 m³/hr MAX.
- Static pressure: 384 Pa.
- Gauge of steel : 0.6mm
- Type of steel (Stainless steel panel): 430 stainless steel
- Finish of steel (Stainless steel panel): brush number 4
- Type of steel (White panel): panel steel
- Finish of steel (White panel): powder coat appliance white
- 240 Volt. 50 Hertz. 290 Watt MAX.
- Tested to EMC AS/NZS – CISPR14:2001
- Electrical approval AS/NZS 3350.2.31.2001
- Performance tested to IEC61591 (replaces AS2682-1984)
- Filter specifications: Three layered micro mesh
- Length of power cord: 1250mm
- Ducting outlet: 150mm diameter round outlet (120 diameter outlet adaptor is also supplied)
- Recirculation option through top ducting outlet

Gross weight: RPA3CI6SS/WH 9.2 kg; RPA3CI9SS/WH 11.5 kg

Carton volume: 0.064m³ (600 model), 0.083m³ (900 model)

Carton dimensions : 567 x 340 x 330mm (600 model), 743 x 340 x 330mm (900 model)

Rangehood dimensions: 520 x 286 x 252mm (600 model), 696 x 286 x 252mm (900 model)

Performance data:

○ RPA3CI6SS/WH

○ RPA3CI9SS/WH

Fan speed 1	412m ³ /hr	Fan speed 1	417m ³ /hr
Fan speed 2	489m ³ /hr	Fan speed 2	491m ³ /hr
Fan speed 3	551m ³ /hr	Fan speed 3	551m ³ /hr
Noise speed 1	51.5dB	Noise speed 1	51.2dB
Noise speed 2	63.6dB	Noise speed 2	62.4dB
Noise speed 3	66.5dB	Noise speed 3	65.6dB

New Zealand

Robinhood Ltd
Telephone: 0800 760 667
Facsimile: 0800 276 246
Email: enquiries@robinhood.co.nz
www.robinhood.co.nz

Australia

Robinhood PTY Ltd
Telephone: 1800 648 556
Facsimile: 1800 628 577
Email: enquiries@robinhood.com.au
www.robinhood.com.au

