

Description:
Model Numbers:

ROBINHOOD WASHING MACHINE AND DRYER STACKING KIT
RHWDSTACKKIT
FOR RHWM9W/RHFL75W & RHHPD7W/RHCD7W

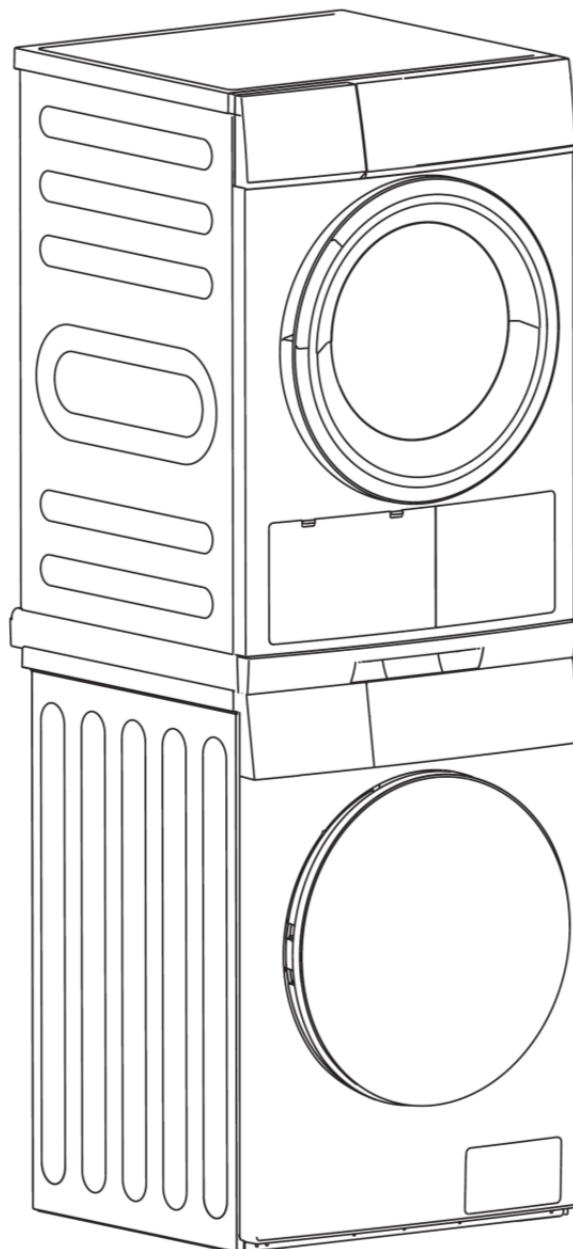

Models may vary slightly from images pictured

Safety Warnings



Please follow the installation manual to ensure you correctly install the stacking kit correct. This stacking kit should only be installed by persons competent in such matters.



Two or more people are needed when installing the dryer on top of the washing machine.



Please ensure that the Washing Machine and Clothes Dryer are not connected to the power supplies prior to installing the stacking kit.



This stacking kit can only be used to stack the nominated Robinhood Clothes Dryers onto the nominated Robinhood Washing Machines. Use on any other models/makes could result in an electrical/safety hazard. Check the Robinhood website or Service Department if unsure before commencing installation.



Do not tilt either appliance more than 30° when installing the kit.



The drawer built into the stacking kit is only suitable for placing clothes. The maximum weight on the drawer should be no more than 16kg. Please do not place objects greater than 16kg, small children or babies on the drawer of the stacking kit.



This kit is supplied with the screws necessary for installation. Do not use different screws than supplied, as this may cause an electrical/safety hazard.



The stacking kit is suitable for installing on front loading Washing Machines with a cabinet depth of 440mm, 510mm or 540mm.



No responsibility will be taken by Robinhood for damage to appliances or injury caused by incorrect installation of this kit.

Parts List

- A- Stacking kit (1)
- B- Screw M6 (1)
- C- Screw M4 (6)
- D- Gasket (1)
- E1-Rear fixing block (Right 1)
- E2- Rear fixing block (Left 1)
- F1- Front fixing block (Right 1)
- F2- Front fixing block (Left 1)
- G- Top panel fixing block (1)

NOTE: Parts E1& E2 are not used in this stacking kit.

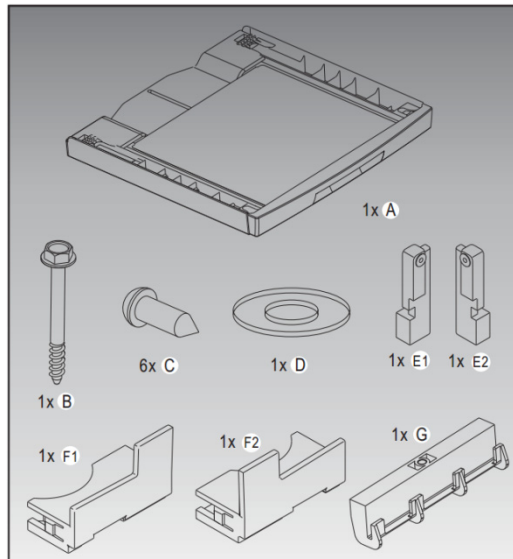

Installation

Step 1: Ensure the installation of the Robinhood front loading washing machine is completed according to the appliance's installation manual, and adjust the balance of the washing machine.

Step 2: Check that all parts listed in the parts list are present.

Step 3: Place the stacking kit on the top panel of the washing machine with the handle of the stacking kit to the front. As shown below, align the stacking kit on top of the washing machine so that it is even on both sides.

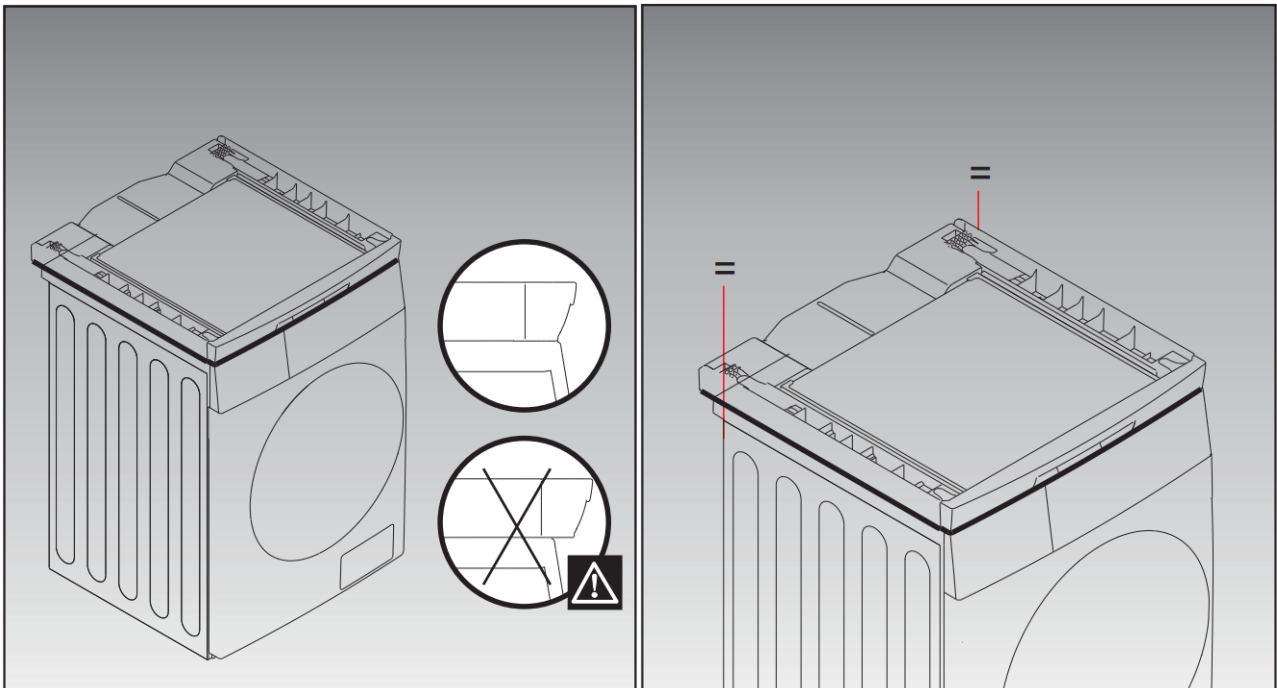

Installation

Step 4: Mark the positions of the six installation screw holes in the stacking kit on the top of the washing machine. Carefully drill through the six pilot holes in the top of the washing machine (take care that the drill it is only as long as the screws supplied). Place the stacking kit back on the washing machine and screw into place using the six screws provided (C). Do not over tighten. Screw in by hand or use a torque less than 10nm).

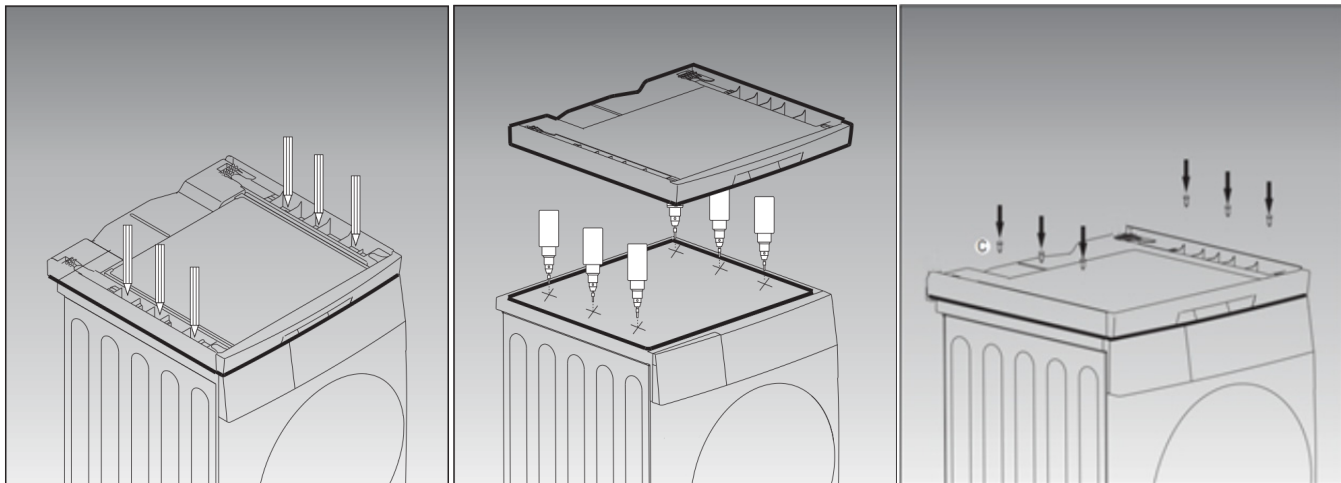

Step 5: Install the top panel fixing block (G). Place the top panel fixing block onto the top panel of the washing machine. Align the mounting hole of the block with the mounting hole of the stacking kit, and fix into place using the supplied M6 screw (B) and gasket (D). Do not over tighten.

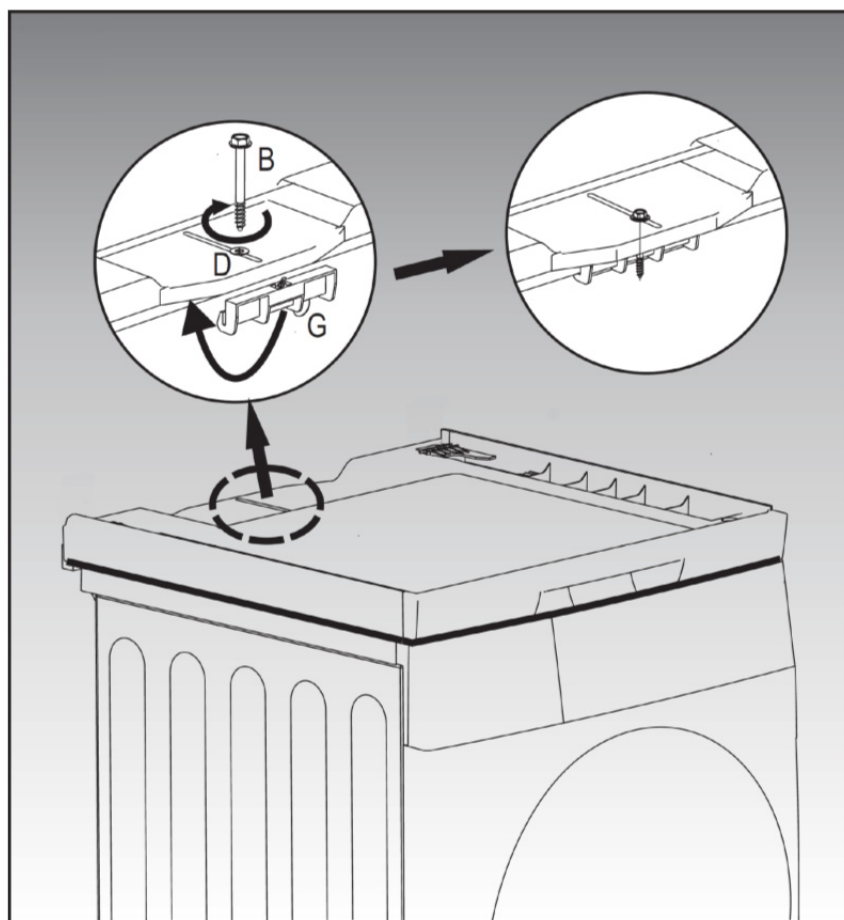

Installation

Step 6: Adjust the feet of the clothes dryer. For clothes dryers with four adjustable feet screw the front feet out by 16mm and the rear feet by 12mm. Check that the clothes dryer sits stable on a flat surface.

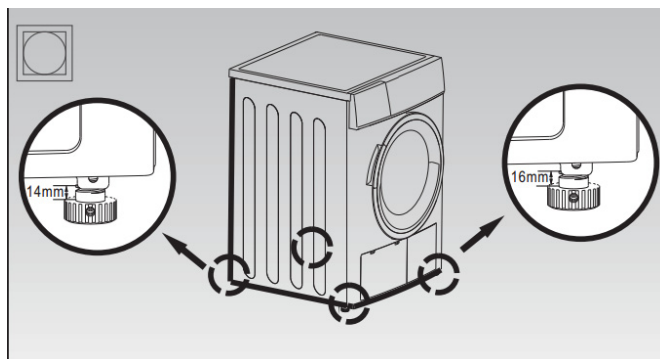

Step 7: Pull the drawer handle out, and place the clothes dryer in the frame of the stacking kit. Note: Place the front feet on the outside of the card slot first, then push the dryer backwards, so that the feet of the dryer slip into the slots. Fit the two front fixing blocks (F1 & F2) into the slots at the front of the stacking kit. Take note of the orientation of the two parts.

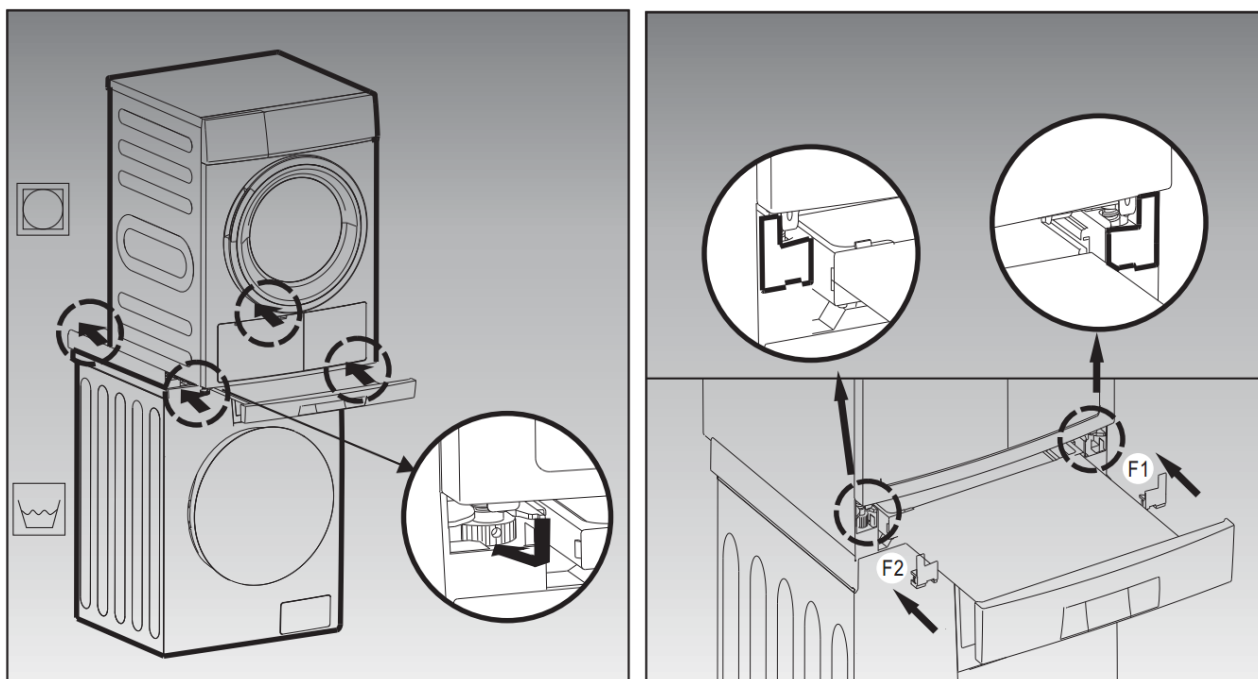

Installation

Step 8: Check that the clothes dryer is not loose inside the stacking kit. Pull out the drawer & check that there is no interference. If this is all good, the installation is complete. Reconnect all power and water sources. When using either appliance for the first time, check that the clothes dryer does not move within the stacking kit. Check that the connections are all still in place periodically.

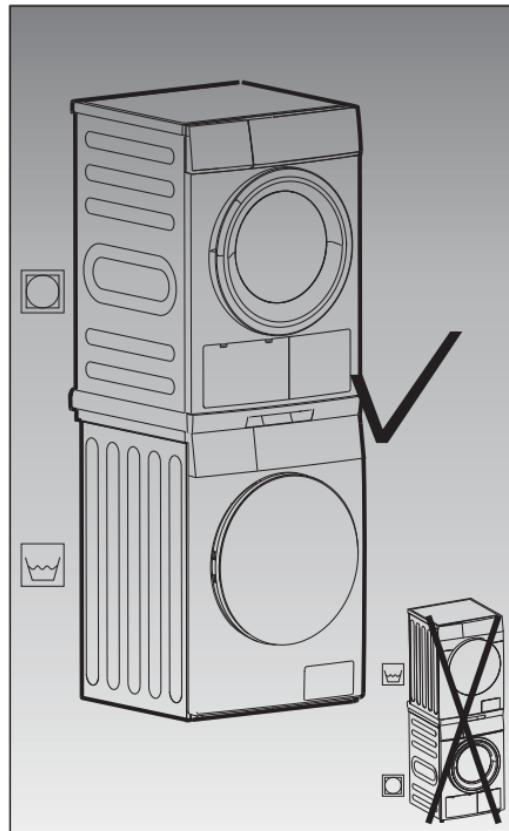

The stacking kit is suitable for use with the following appliances:
RHHPD7W/RHCD7W
RHWM9W/RHFL75W

Warranty Certificate (New Zealand)

Terms and Conditions

The following conditions apply in respect of the warranty given in this certificate:

1. Monaco Corporation Limited ("Monaco") warrants the following Robinhood products against manufacturing defects and faulty materials, under normal use and subject to the exclusions in this certificate, for a period of:
Rangehood, Ovens, Cooktops, Dishwashers, Refrigeration, Washing machines, Clothes Dryers - 24 months from date of original purchase for domestic use.
Uniduct – 12 months from date of original purchase for domestic use.
Ironing centre – 12 months from date of original purchase for domestic use.
Taps, including Pull-out and Mixer taps – 5 years on parts only from date of original purchase domestic for use, 24 months parts and labour from date of original purchase for domestic use
Sinks sets– 5 years on stainless steel sink including draining bench from date of original purchase for domestic use, 6 months on all stainless steel accessories, including wire rack, colander and tray from date of original purchase for domestic use.
Laundry Tub - 5 years on stainless bowl, 24 months on Tap, Cabinet and other components from the date of original purchase for domestic use.

"Original purchase", when used in this certificate, means purchase by the customer directly from Monaco or one of its approved suppliers.

2. This warranty is limited to the repair or replacement, at our option, within the warranty period of any component part which we at our discretion determine to contain faulty materials or a manufacturing defect in breach of this warranty. This warranty is subject to terms and conditions set out in this certificate.
3. The warranty only applies within New Zealand.
4. The customer must produce the original invoice or other purchase documentation as proof of the original purchase date.

Warranty exclusions

1. The warranty does not apply where, in Monaco's opinion:
The defect is caused by misuse, wear and tear, dirt, fire or accidental damage.
The product has been repaired or serviced by an unauthorised person.
The product was not installed in accordance with our instructions.
The product was purchased overseas or was not designed for use in New Zealand.
The product was not used, cleaned or cared for in accordance with our instructions.
The product was used outdoors.
2. In addition, this warranty does not extend to damage or defects which in our opinion, directly or indirectly arise from or are due to:
Exposing the product to acidic or corrosive materials or chemicals such as dyes, solvents, denture cleaner or acetone;
Using inappropriate household cleaning products such as abrasive cream or powder cleansers, furniture polish, bleach, mentholated spirits, drain cleaners, sugar soap, metal pads and strongly alkaline or acidic cleaners;
Heat damage, including from washing the product at high temperatures;
Impact or mishandling the product, including the impact caused by objects scraped along, thrown or dropped on the product surface or excessive weight being placed on the product;
Structural or support changes in or affecting the building or the application where the product has been installed;
Failure to clean or maintain the product as recommended; or
any other causes specified in the product information as being excluded from this warranty.
3. Variations with the colour or gloss within the product or any ageing or fading of colour, shine or gloss level over time are not covered by this warranty. The warranty does not cover visual imperfections or blemishes in the surface and edges of the product that were not brought to your supplier's attention at the time you inspected the product.
4. Costs incurred on installation or removal of a product, or any reinstallation of a product, or any associated costs, are not covered by this warranty.
5. Monaco will not be liable for consequential or indirect loss or damage whatsoever and however arising out of or in connection with the supply, performance or removal of the product, including (but not limited to) loss of profit, loss of revenue, loss of contract, loss of goodwill or increased cost of workings, even if due to the negligence of Monaco or any of its approved suppliers, employees or agents.
6. Charcoal filters and light bulbs are not covered by this warranty
7. This warranty and the statements contained in this certificate or other documents given to you do not exclude, restrict or modify the application of any term implied into this warranty by statute, provided that (to the extent any statutory provision permits Monaco to limit its liability for a breach of an implied condition or warranty) Monaco's liability for such breach is limited to the payment of the cost of replacing the product, repairing the product or acquiring an equivalent product.
8. Subject to clause 5, our obligations under this warranty are limited to those set out in this certificate, and this warranty is expressly instead of all other warranties, express or implied, including any implied warranty of merchantability or fitness for a particular purpose and notwithstanding any course of dealing between the parties or custom and usage in trade to the contrary.

Terms and conditions are subject to change.

Warranty Certificate (Australia)

Terms and Conditions

If you are a consumer under the Australian Consumer Law, our goods come with guarantees that cannot be excluded under the Australian Consumer Law. You are entitled to a replacement or refund for a major failure and for compensation for any other reasonably foreseeable loss or damage. You are also entitled to have the goods repaired or replaced if the goods fail to be of acceptable quality and the failure does not amount to a major failure

1. Shriro Australia Pty Limited ("Shriro") also warrants the following Robinhood products against manufacturing defects and faulty materials, under normal use and subject to the exclusions in this certificate, for a period of:

Rangehood, Ovens, Cooktops, Dishwashers, Refrigeration, Washing machines, Clothes Dryers - 24 months from date of original purchase for domestic use.

Uniduct – 12 months from date of original purchase for domestic use.

Ironing centre – 12 months from date of original purchase for domestic use.

Taps, including Pull-out and Mixer taps – 5 years on parts only from date of original purchase domestic for use, 24 months parts and labour from date of original purchase for domestic use

Sinks sets– 5 years on stainless steel sink including draining bench from date of original purchase for domestic use, 6 months on all stainless steel accessories, including wire rack, colander and tray from date of original purchase for domestic use.

Laundry Tub - 5 years on stainless bowl, 24 months on Tap, Cabinet and other components from the date of original purchase for domestic use. "Original purchase", when used in this certificate, means purchase by the customer directly from Shriro or one of its approved suppliers.

2. This warranty is limited to the repair or replacement, at our option, within the warranty period of any component part which we at our discretion determine to contain faulty materials or a manufacturing defect in breach of this warranty. This warranty is subject to terms and conditions set out in this certificate.

3. The warranty only applies within Australia.

4. For warranty service outside of capital city metropolitan area or 30 km from nearest authorised service agent you will be liable for reasonable travelling expenses and the cost of transport of the product or parts to and from the service agent

5. To make a claim under this warranty, you must produce the original invoice or other purchase documentation as proof of the original purchase date.

You must send your claim to Shriro Australia Pty Limited, 104 Vanessa Street, Kingsgrove NSW 2208 within 7 days of any alleged defect or failure of the product first becoming apparent, you are responsible for the expense of making a claim under this warranty.

This warranty is given by:

Shriro Australia Pty Ltd

ABN 28 002 386 129

Telephone: 1800 648 556

Facsimile: 1800 628 577

Email: enquiries@robinhood.com.au

www.robinhood.com.au

Attention Customer Services Manager

Warranty exclusions

1. The warranty does not apply where, in Shriro's opinion:

The defect is caused by misuse, wear and tear, dirt, fire or accidental damage.

The product has been repaired or serviced by an unauthorised person.

The product was not installed in accordance with our instructions.

The product was purchased overseas or was not designed for use in Australia.

The product was not used, cleaned or cared for in accordance with our instructions.

The product was used outdoors.

2. All Robinhood Rangehoods are suitable for indoor use only and not suitable over BBQs or charcoal cookers designed for outdoor use.

3. In addition, this warranty does not extend to damage or defects which in our opinion, directly or indirectly arise from or are due to: exposing the product to acidic or corrosive materials or chemicals such as dyes, solvents, denture cleaner or acetone; using inappropriate household cleaning products such as abrasive cream or powder cleansers, furniture polish, bleach, mentholated spirits, drain cleaners, sugar soap, metal pads and strongly alkaline or acidic cleaners; heat damage, including from washing the product at high temperatures;

impact or mishandling the product, including the impact caused by objects scraped along, thrown or dropped on the product surface or excessive weight being placed on the product; structural or support changes in or affecting the building or the application where the product has been installed; failure to clean or maintain the product as recommended; or any other causes specified in the product information as being excluded from this warranty.

4. Variations with the colour or gloss within the product or any ageing or fading of colour, shine or gloss level over time are not covered by this warranty. The warranty does not cover visual imperfections or blemishes in the surface and edges of the product that were not brought to your supplier's attention at the time you inspected the product.

5. We will not be responsible under this warranty for, nor pay the costs of, removing the existing product, or reinstalling the new product, or any associated costs or damages.

6. Charcoal filters and light bulbs are not covered by this warranty

The benefits given by this warranty are in addition to other rights and remedies of consumers under any law in relation to the goods which cannot be excluded.

This warranty certificate is not intended to create a contract between Shriro Australia Pty Limited and the purchaser.

New Zealand

Monaco Corporation Ltd

Telephone: (09) 415 6000

Facsimile: (09) 415 7400

Email:

customer-care@monacocorp.co.nz

www.robinhood.co.nz

Australia

Shriro Australia Pty Limited

ABN 28 002 386 129

Telephone: 1800 648 556

Facsimile: 1800 628 577

Email: customer-care@shriro.com.au

www.robinhood.com.au

