

Description: **ROBINHOOD 90CM CURVED GLASS ISLAND CANOPY RANGEHOOD**
 Model Number: **RIV3CL9G**

Typical design

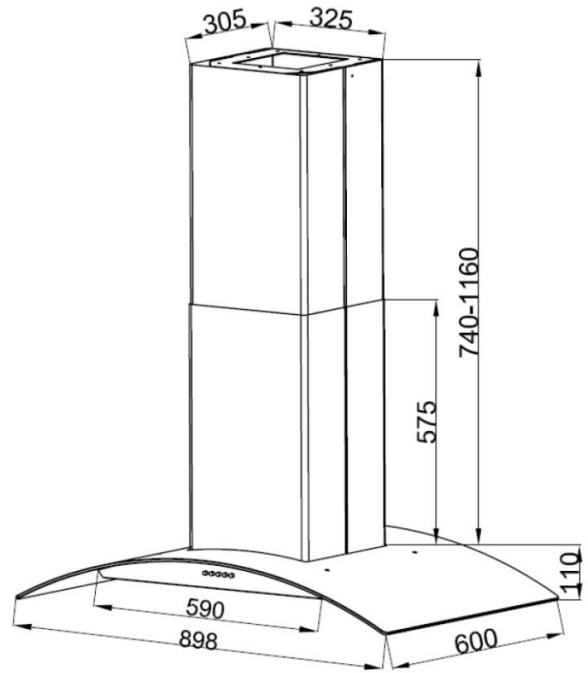

Features and benefits

- **High performance extraction fan**
 With a max gross airflow 800 m³/hr, high performance extraction fan rapidly removes steam, smoke and cooking smells from your kitchen. Three-speed switch lets you select the fan strength you need.
- **LED lamps**
 4x 1.5W LED lamps efficiently illuminate the entire cooking surface.
- **Multi-layered micromesh filters**
 Multi-layered micromesh filters effectively trap grease. They're simple to remove and are easily maintained with a regular clean in the dishwasher.
- **Dual Side Controls**
 Full electronic controls on both sides mean the rangehood can be controlled whatever side of the island you're on.
- **Extra-wide design**
 Tempered safety glass hood with Stainless Steel body in extra wide design that is perfect for wide cooktops, like six-burner cooktops.
- **Thermal overload switch**
 Thermal overload function that senses extreme heat and disconnects power to the motor temporarily. If you have a cooking disaster, and something catches fire, the rangehood automatically switches off to prevent flames and sparks being sucked into the ducting or ceiling.
- **Delay timer**
 Rangehood turns off automatically after 15 mins, clearing away all residual cooking odors and steam.

Specifications

Technical data:

Motor type	3 speed centrifugal motor
Lights	4 x 1.5 Watt LED lamps
Type of steel	430 stainless steel
Finish of steel	Brush number 4
Power	223W, 220-240 Volt,50 hertz
Electrical approval AS/NZS	60335.2.31:2004 + A1, A2, A3
EMC AS/NZS	CISPR14:2001
Performance tested to	IEC61591
Filter	Multi- layered micro mesh
Length of power cord	1500mm
Ducting outlet	150mm diameter round outlet – top ducting
Recirculation option	No, ducted only

Gross weight: 30.0kg.

Carton volume: 0.287m³

Carton dimensions : W980W x D450 x H650mm

Rangehood dimensions: W898 x D600 x H850-1270

Performance data:

- RIV3CL9G

Fan speed 1	485 m ³ /hr
Fan speed 2	600 m ³ /hr
Fan speed 3	740 m ³ /hr
Noise speed 1	53 dB
Noise speed 2	58 dB
Noise speed 3	62 dB

New Zealand

Monaco Corporation Ltd
Telephone: (09) 415 6000
Facsimile: (09) 415 7400
Email: enquiries@robinhood.co.nz
www.robinhood.co.nz

Australia

Shiro Australia Pty Ltd
ABN 28 002 386 129
Telephone: 1800 648 556
Facsimile: 1800 628 577
Email: enquiries@robinhood.com.au
www.robinhood.com.au

