

Description: **ROBINHOOD ISLAND CANOPY**
Model Number: **RIE3CL9SS**

Typical design

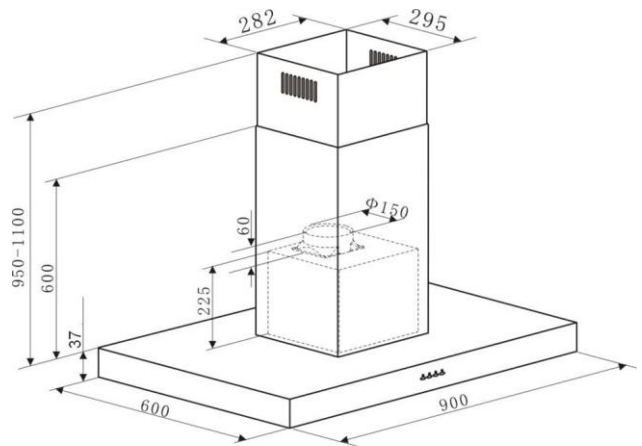

Features and benefits

- **High performance extraction fan**
High performance extraction fan rapidly removes steam, smoke and cooking smells from your kitchen. Three-speed switch lets you select the fan strength you need – half strength for steamed vegetables; full strength for stir fries.
- **LED Lamps**
4x 3 watt LED lamps efficiently illuminate the entire cooking surface.
- **Multi-layered micromesh filters**
Multi-layered micromesh filters effectively trap grease. They're simple to remove and are easily maintained with a regular clean in the dishwasher.
- **Dual Side Controls**
Control panels on both sides mean the rangehood can be controlled whatever side of the island you're on.
- **Rectilinear design**
Simple styling makes cleaning easy. High quality stainless steel and the fingertip controls are easy to clean with a damp cloth.
- **Thermal overload switch**
Thermal overload function that senses extreme heat and disconnects power to the motor temporarily. If you have a cooking disaster, and something catches fire, the rangehood automatically switches off to prevent flames and sparks being sucked into the ducting or ceiling.
- **Recirculation option**
In situations where ducting isn't possible, your rangehood can be fitted with charcoal filters that effectively cleanse the air before returning it to the kitchen.

Specifications

Technical data:

- 3 speed centrifugal motor
- 4 x 3 Watt LED lamps
- Gauge of steel: 0.6 mm
- Type of steel: 430 stainless steel
- Finish of steel: brush number 4
- 240 Volt. 50 Hertz. 277 Watt Max.
- Tested to EMC AS/NZS – CISPR14:2001
- Electrical approval: AS/NZS 60335.2.31:2004 + A1, A2, A3
- Performance tested to IEC61591 (replaces AS2682-1984)
- Filter specifications: three layered micro mesh
- Length of power cord: 1500mm
- Ducting outlet: 150mm diameter round outlet – top ducting
- Recirculation option through top duct outlet (charcoal filter 2620 – 3 Pack)

Gross weight: RIE3CL9SS 30.0kg.

Carton volume: 0.281m³

Carton dimensions : 650 x 370 x 550mm (600 model), 955 x 370 x 550mm (900 model)

Rangehood dimensions: 900 x 600 x 600-1100

Performance data:

- RIE3CL9SS

Fan speed 1	485 m ³ /hr
Fan speed 2	729 m ³ /hr
Fan speed 3	902 m ³ /hr
Noise speed 1	49 dB
Noise speed 2	59 dB
Noise speed 3	64 dB

New Zealand

Monaco Corporation Ltd
Telephone: (09) 415 6000
Facsimile: (09) 415 7400
Email: enquiries@robinhood.co.nz
www.robinhood.co.nz

Australia

Shiro Australia Pty Ltd
ABN 28 002 386 129
Telephone: 1800 648 556
Facsimile: 1800 628 577
Email: enquiries@robinhood.com.au
www.robinhood.com.au

