

Description

ROBINHOOD STAINLESS STEEL/BLACK GLASS WALL CANOPY
RHWC60TB (ARGUS 60); RHWC90TB (ARGUS 90)



RHWC60TB



RHWC90TB

Key Features

Max Motor Performance

1200 m³/hr

AC Motor

Fully sealed AC motor in weldless casing

Metal Fan Blades

With Teflon finish to ensure smooth air flow

Slide/Touch Control

User friendly control enables easy operation

Lower Noise Level

46dB at power level 1

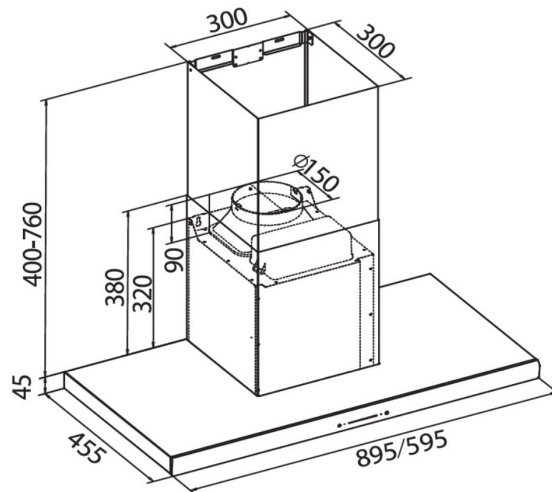

Specifications

AESTHETICS

Rangehood Type	Wall Canopy
Finish	Stainless Steel + Black Glass
Filter Type	Decorative SS/Aluminium Filters
No. of Filters	RHWC60TB: 2 PCs RHWC90TB: 3 PCs
Light	2 * 2W LED

TECHNICAL DETAILS

Power Levels	3 + Intensive
Motor Wattage	180W
Voltage/Frequency	240V/50Hz
Total Power Consumption	184W
Plug	Fitted, 10AMP

DUCTING

Ducting Diameter	Ø150mm
Ducting Type	Can be ducted or recirculated
Optional Charcoal Filter	CARBONFTLDEEU (Pack of 2) EXTKITDEEU27 (For 2.7m stud)
Optional Extension Flue	EXTKITDEEU30 (For 3.0m stud)

DIMENSIONS & WEIGHTS

	RHWC60TB	RHWC90TB
Chimney Size (W*D*H)	300*300*(400-760)mm	300*300*(400-760)mm
Product Dimensions (W*D*H)	595*455*(445-805)mm	895*455*(445-805)mm
Carton Dimensions (W*D*H)	655*530*530mm	955*530*530mm
Net/Gross Weight	17.5/19.0Kg	19.0/24.0Kg

IEC 61591 Test Data		
Power Level	Air Flow (m ³ /hr)	Noise Level (dB)
1	520	46
2	633	51
3	819	55
Intensive	965	61