

Description: **ROBINHOOD 60CM BUILT-IN OVEN 9 FUNCTIONS, 72L, TOUCH CNTRL FULLY PRG**

Model Number: **RHBO69BX**

Typical design



Dimensions

Oven size	
Width	595mm
Depth	565mm
Height	595mm

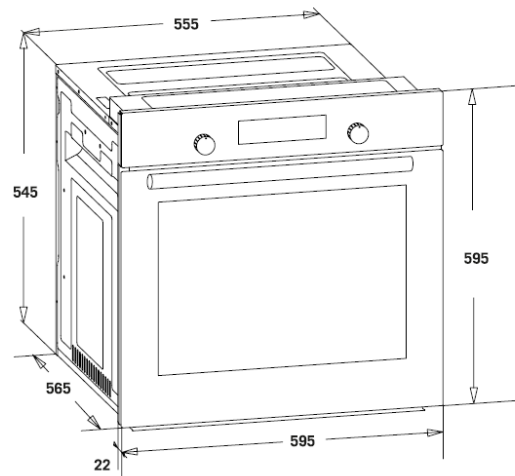

Specifications

Electrical specifications

Voltage:	220-240 50hz
Top heating element:	1,000W
Bottom heating element:	1,200W
Grill heating element:	2,000W
Cooling fan:	20W
Turbo heating element:	1,800W
Oven lamp (15W):	Square lamp X2
Turbo fan:	24W
Front panel:	Black glass panel + Inox finish
Timer:	Digital Timer Programmer (6 touch) White
Functions:	Lamp only,Bake,Steam assisted cleaning, Upper element, Grill,Grill with fan,Fan bake,Rear element with fan &Defrost
Volume type:	72L
Door type:	Removable glass oven door
Low-E glass:	Yes
Door glass type:	Triple glass
Knob:	Z Black model
Handle:	T2 Model with black plastic foot
Cavity type:	Black enamel
Tray:	1
Wire shelf:	2
Side wire racks:	Yes (4 level)
Nett weight:	27.7kg
Gross weight:	26.5kg
Carton dimensions:	660mm*655mm*640mm
Carton volume:	0.28m ³

New Zealand

Monaco Corporation Ltd
Telephone: (09) 415 6000
Facsimile: (09) 415 7400
Email: enquiries@robinhood.co.nz
www.robinhood.co.nz

Australia

Shriro Australia Pty Ltd
ABN 28 002 386 129
Telephone: 1800 648 556
Facsimile: 1800 628 577
Email: enquiries@robinhood.com.au
www.robinhood.com.au