

Description: **ROBINHOOD 60CM BUILT-IN OVEN 5 FUNCTIONS 70L BLACK**

Model Numbers: **OBD605K70B**



Model Pictured: OBD605K70B

\*Actual product may vary from the picture

# Contents

## Congratulations!

Thank you for choosing one of our appliances. Before you use the appliance, we strongly recommend that you read through the whole user manual which provides important safety instructions and description of the product and the proper use of its functions.

To avoid the ever-present risks involved with using an electrical appliance it is vital that the oven is installed correctly and that you read the safety instructions carefully to avoid misuse and hazards. It is important that you retain these instructions and your proof of purchase along with any other important documents about this product for future reference.

Due to continual product development, Robinhood reserves the right to alter specifications or appearances without notice.

Important Safety Instructions.....	1
Electrical Connection.....	2
Appliance Details.....	3
Installation.....	4
Accessories.....	5
Operating Instructions.....	6-7
Before Using the Oven for the First Time.....	7
Maintenance and Cleaning.....	8-9
Troubleshooting.....	10
Warranty Certificate (New Zealand).....	11
Warranty Certificate (Australia).....	12

## Disposal Information

- Most of the packing materials are recyclable. Please dispose of these materials through your local recycling depot or by placing them in appropriate collection containers.
- If you wish to discard this product, please contact your local authorities and ask for the correct method of disposal.

## Important Safety Instructions

This User Instruction Manual contains important information, including safety & installation points, which will enable you to get the most out of your appliance. Please keep it in a safe place so that it is easily available for future reference; for you or any person not familiar with the operation of the appliance.

- This appliance and its accessible parts become hot during use. Care should be taken to avoid touching heating elements.
- Children less than 8 years of age shall be kept away unless continuously supervised.
- This appliance is not intended for use by persons (including children) with reduced physical, sensory or mental capabilities, or lack of experience and knowledge, unless they have been given supervision or instruction concerning use of the appliance by a person responsible for their safety.
- Children should be supervised to ensure that they do not play with the appliance.
- A steam cleaner is not to be used to clean this appliance.
- Do not use harsh abrasive cleaners or metal scrapers to clean the oven door glass as this can scratch the surface, which may result in the oven glass shattering.
- **Warning:** The appliance must not be installed behind a decorative door in order to avoid overheating.
- The air must not be discharged into a flue that is used for exhausting fumes from appliances burning gas or other fuels.



### Danger of fire

- Do not allow paper or cloth to come into contact with any heating element.
- Never store or use corrosive chemicals, vapors, flammables or nonfood products in or near the oven. It is specifically designed for use when heating or cooking food. The use of corrosive chemicals in heating or cleaning will damage the appliance and can result in injury
- If food inside an oven should ignite, keep the door closed. Switch off the oven and disconnect from the power supply.
- Exercise caution when opening the door. Standing to the side, open the door slowly and slightly to let hot air and/or steam escape. Keep your face clear of the opening and make sure there are no children or pets near the oven. After the release of hot air and/or steam, proceed with your cooking. Keep the door closed at all times unless necessary for cooking or cleaning purposes.
- Only use utensils that are suitable for use with ovens.



### Warning: Danger of explosion

- Liquids and other foods must not be heated in sealed containers as they are liable to explode.
- If smoke is observed, switch off the oven and keep the door closed in order to stifle any flames.
- Do not allow any accessories or electric cables to come into contact with the hot parts of the oven.



### Warning: Hot surfaces; risk of burns

- During use the appliance becomes hot. Care should be taken to avoid touching heating elements inside the oven.
- **Warning:** Accessible parts may become hot during use. Young children should be kept away.
- Never move racks or pans when they are hot. Wait until they cool.
- This appliance is designed for domestic household use and can be built into a standard kitchen cabinet or housing unit.
- Certain types of vinyl or laminate kitchen furniture are particularly prone to heat damage or discolouration at high temperatures.
- Do not place heavy objects on the oven door or lean them against the oven door whilst it is open, as this can cause damage to the oven door hinges.
- Do not leave hot oil or fat unattended as it is a fire hazard.
- Do not place pans or baking trays directly onto the base of the oven cavity, even if aluminum foil is placed underneath them.
- Do not allow the power cable or plug to come into contact with the hot areas of appliance.
- Do not install the appliance next to curtains or soft furnishings.
- Do not attempt to lift or move the oven by the oven door or handle, as this can damage it or result in injury to the person lifting the oven.
- **Warning:** Do not install behind a decorative door in order to avoid overheating.

# Electrical Connection

## Electrical Safety



### Danger of electric shock

- If the supply cord is damaged, it must be replaced by the manufacturer, its service agent or similarly qualified persons in order to avoid a hazard.
- **Note:** The appliance must be placed in such a way that the power supply is accessible at all times.
- Before connecting the appliance to the power supply, check that the power supply voltage and current rating corresponds with the power supply details shown on the appliance rating label.
- Never use a damaged appliance. Disconnect the appliance from the power source and contact your supplier if it is damaged.
- Danger of electric shock. Do not attempt to repair the appliance yourself. In case of malfunction, repairs are to be conducted by qualified personnel only.
- To avoid damaging the cord, do not squeeze, bend or chafe it on sharp edges. Keep the cord away from hot surfaces and open flames.
- Lay out the cord in such a way that no unintentional pulling or tripping over it is possible.
- Do not open the appliance casing under any circumstances. Do not insert any objects into the casing.
- Never use accessories which are not recommended by the manufacturer. They could pose a safety risk to the user and might damage the appliance. Only use original parts and accessories.
- Do not place objects with open flames, e.g. candles, on top, beside or inside the appliance.
- **WARNING:** Ensure that the appliance is switched off before replacing the lamp to avoid the possibility of electric shock.
- Fixed wiring for the appliance shall have an all-pole disconnection device.
  
- Any electrical installation must be carried out by an authorised professional.
- All fittings must be installed by a competent person in accordance with local regulations. If in doubt, consult a qualified electrician.
- **Important:** Always switch off the electricity supply at the mains during installation and maintenance. It is recommended that the fuse is withdrawn or circuit breaker switched off at the distribution board whilst work is in progress.
- This product must be earthed – if no earth feed wire is available, consult an electrician.
- Means for disconnection must be incorporated in the fixed wiring in accordance with the wiring rules. To achieve this install appropriate switched fused connection unit.
- **Note:** A switched fused connection unit having a contact separation of at least 3mm in all poles should be connected in fixed wiring.
- Connect the incoming positive, neutral and earth cables to the terminals of the switched fused connection unit. Ensure connections are tight.
- The spur outlet must still be accessible even when your oven is located in its housing to enable the appliance to be disconnected from the mains supply.

## Connection to the mains supply



### This appliance must be earthed

Our company shall not be held responsible for any damage caused by using the appliance without an earthed socket. There is a risk of electric shock, short circuit or fire when not installed by a professional. The appliance may be connected to the mains supply only by an authorized qualified person and the appliance is only guaranteed after correct installation.

There is a risk of electric shock, short circuit or fire if the mains lead is damaged in any way. The mains lead must not be clamped, bent or trapped or come into contact with hot parts of the appliance. If the mains lead is damaged, it must be replaced by a qualified electrician.

The mains supply must correspond to the data specified on the rating plate of the appliance. The appliance mains cable must correspond to the specifications and the power consumption.

## Appliance Details

<b>Voltage/frequency</b>	220-240V~50Hz
<b>Total power consumption</b>	2300W
<b>Cable type/section</b>	H05VV-F 3*1.5mm <sup>2</sup>
<b>Cable length</b>	1.2m
<b>External dimensions(height/width/depth)</b>	595/595/575 (mm)
<b>Installation dimensions(height/width/depth)</b>	600/600/565 (mm)
<b>Oven lamp</b>	25W/300°C
<b>Grill power consumption</b>	2250W

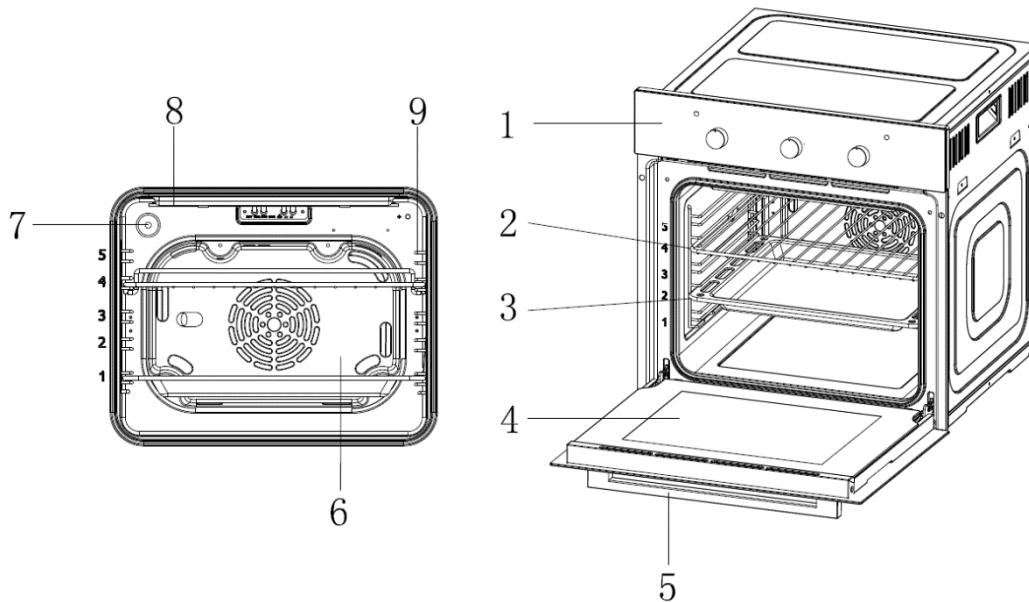

- |                  |                                   |
|------------------|-----------------------------------|
| 1. Control Panel | 6. Fan Motor (behind steel plate) |
| 2. Wire Rack     | 7. Lamp                           |
| 3. Tray          | 8. Grill Heating Element          |
| 4. Door          | 9. Side Shelf                     |
| 5. Handle        |                                   |

# Installation

The oven should be installed into a purpose built cabinet. Ensure that there is adequate space between the sides of the oven and the walls of the cabinet for ventilation (see the image below for details).

- Surfaces, synthetic laminates and adhesives used must be heat resistant (100°C minimum), and neighboring unit fronts up to 70°C.
- Kitchen cabinets must be set level and fixed. A gap of 5mm is required between the oven and surrounding unit fronts.
- If there is a drawer beneath the oven, a shelf must be installed between oven and drawer.
  - **Warning:** Handles for drawers and cupboards below the oven may become hot during use.

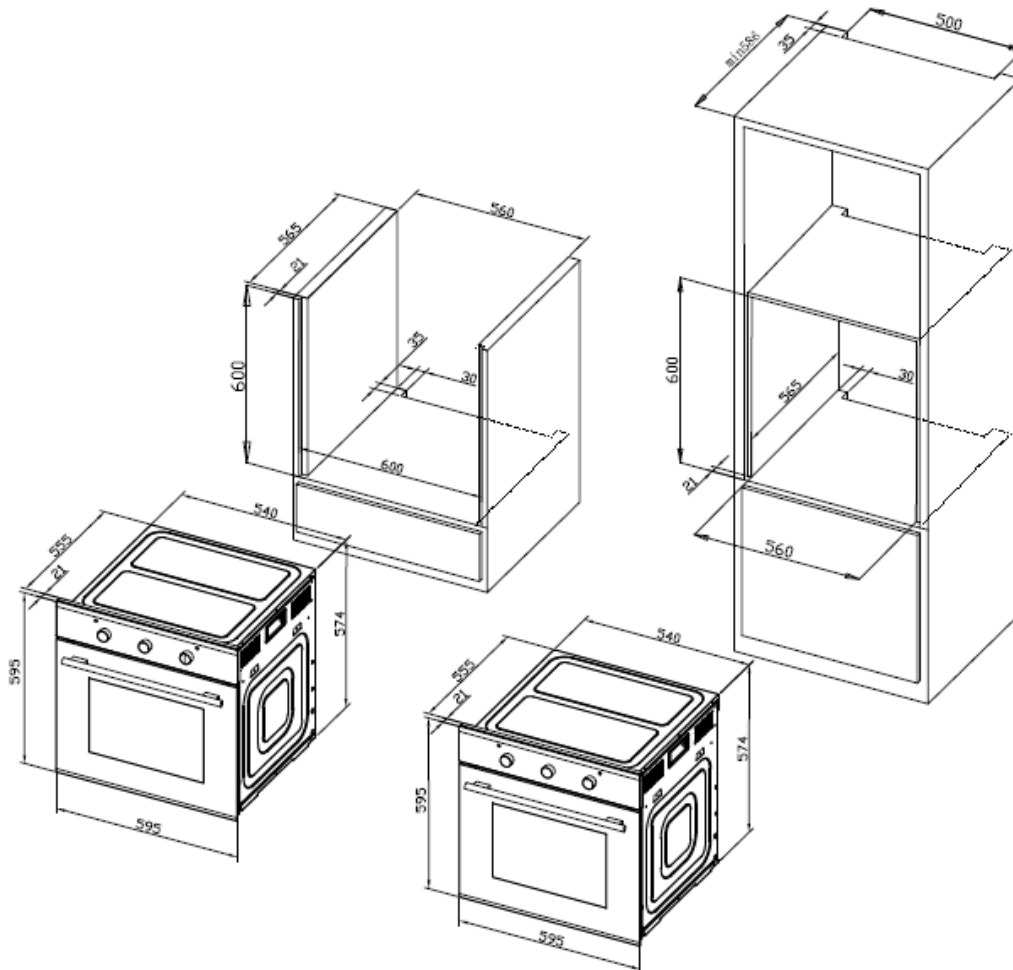

- Slide the oven through the cabinet aperture, align and secure.
- Fix your oven with the 2 screws and washers as indicated in the figure.

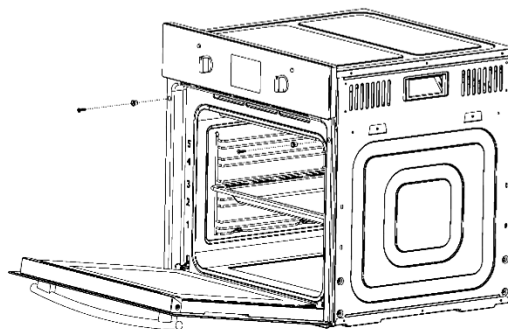

## Final check

1. Connect the appliance to the mains supply and switch on.
2. Check that the oven functions.

## Accessories

The accessories supplied with your appliance are suitable for making many different types of meals. Ensure that you always insert the accessories into the cooking compartment in the correct orientation.

### Inserting accessories

You can insert the accessories into the cooking compartment at 5 different levels. Always insert them as far as they will go so that the accessories do not touch the door panel.

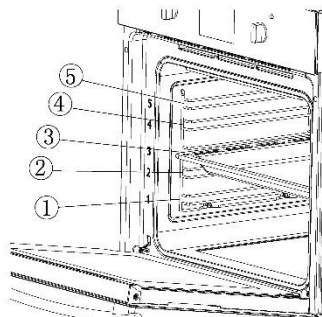

Accessories can be pulled out approximately halfway until they lock in place. This allows dishes to be removed easily.

**Note:** Accessories may temporarily deform when they become hot. Once they cool down, they regain their original shape. This does not affect normal operation.

### Oven Pan

For moist cakes, pastries, frozen meals and large roasts. It can also be used to catch dripping fat when you are grilling directly on the wire rack.

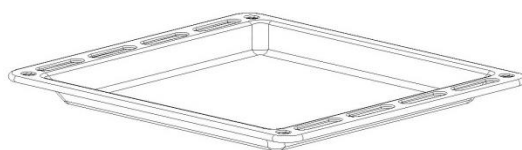

### Wire Rack

Used for roasting and for placing food to be baked, roasted or cooked in casserole dishes at the desired level.

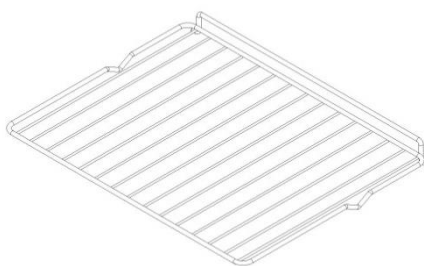

### Side Shelf

Provides five different levels for the above accessories to be placed.

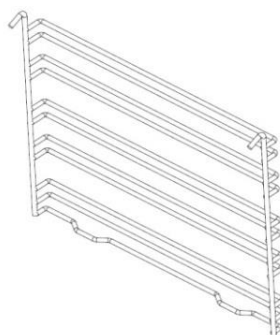

# Operating Instructions

## Control Panel

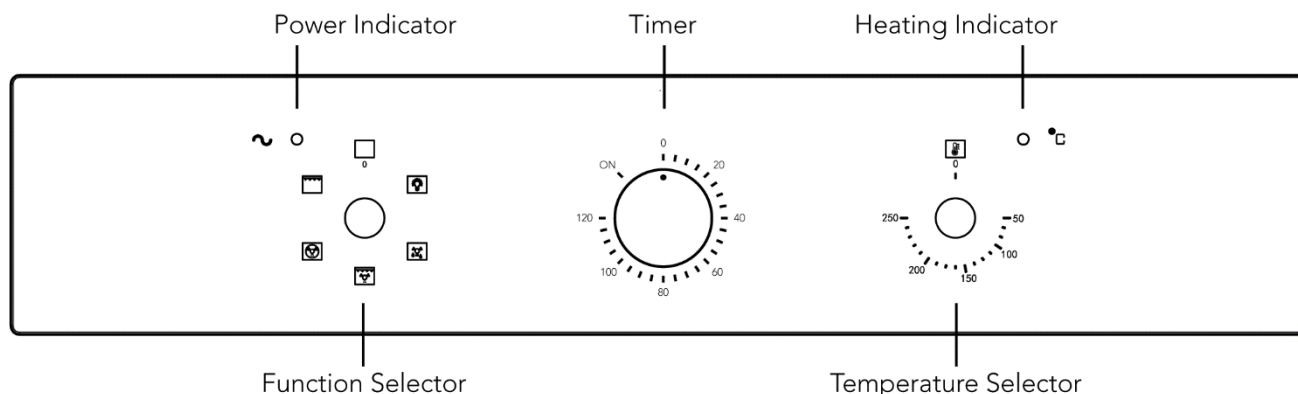

## Function selector

Use the function selector to set the type of heating. There are five functions available:



### OVEN LIGHT

Press to turn the interior light on and off.



### DEFROST

The fan runs without heat to reduce the defrosting time of frozen foods. The time required to defrost the food will depend on the room temperature, the quantity and type of food.



### FAN AND GRILL

This method of cooking utilises the top element in conjunction with the fan, which helps to provide a quick circulation of heat. This function is suitable where quick browning is required and "sealing" the juices in, such as steaks, hamburgers, some vegetables etc.



### CONVENTIONAL GRILL

This method of cooking utilises the inner and outer parts of the top element, which directs heat downwards onto the food. This function is suitable for grilling medium or large portions of sausages, bacon, steaks, fish etc.



### FAN FORCED

This method of cooking uses the circular element whilst the heat is distributed by the fan. This results in a faster and more economical cooking process and allows food to be cooked simultaneously on different shelves, preventing the transmission of smells and tastes from one dish to another.

## Oven Timer

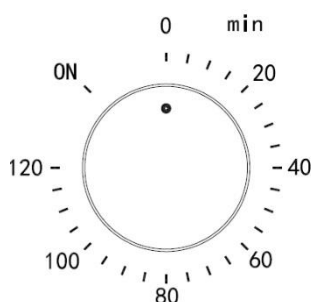

If you do not wish to use the timer, set the dial to the 'On' position. This will allow you to use the oven in manual mode.

To use the timer, set the dial to the desired amount of time (in a range of 0 – 120 minutes). The oven will automatically turn off when the time limit is reached.



# Operating Instructions

## Thermostat

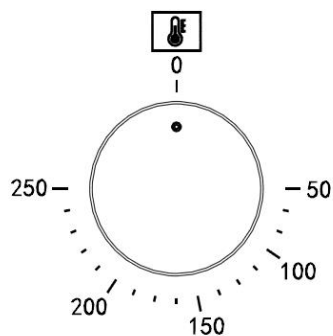

The oven thermostat control dial sets the required temperature of the oven. It is possible to regulate the temperature within a range of 50 - 250°C.

## Before Using the Oven for the First Time

### Heating the Oven

To remove the new oven smell, heat up the oven whilst it is empty and closed. Let the oven run for an hour with both top and bottom elements on. A temperature of 240°C is ideal for this purpose. Ensure that no packaging has been left inside or attached to the oven.

- Use the function selector to set Top / Bottom heating.
- Set the thermostat to 240°C. After an hour, switch off the oven. To do so, turn the function selector to the off position.

### Cleaning the Accessories

Before you use the accessories for the first time, clean them thoroughly with hot soapy water and a soft dish cloth.

## Maintenance and Cleaning

- The oven should be cleaned after every use.
- The oven chamber should only be washed with warm water and a small amount of washing-up liquid.
- After cleaning the oven chamber wipe it dry.
- Never clean the oven surfaces by steam cleaning.
- The oven cavity should only be cleaned with warm soapy water, using either a sponge or soft cloth. No abrasive cleaners should be used.
- Any stains that may appear on the bottom of the oven will have originated from food splashes or spilt food. These splashes occur during the cooking process. These could possibly be a result of the food being cooked at an excessively high temperature or being placed in cookware that is too small.
- You should select a cooking temperature and function that is appropriate for the food that you are cooking. You should also ensure that the food is placed in an adequately sized dish and that you use the drip tray where appropriate.
- Outer parts of the oven should only be cleaned with warm soapy water, using either a sponge or soft cloth. No abrasive cleaners should be used.
- If you use any form of oven cleaner on your appliance, then you must check with the manufacturer of the cleaner that it is suitable for use on your appliance.
- Do not use cleaning products containing abrasive materials for the cleaning and maintenance of the glass front panel.
- No oven cleaner or any other special cleaning agent is required for cleaning the oven. It is recommended to wipe the oven with a damp cloth while it is still warm.

### Removing the Door

To make it easier to clean the inside of your oven, the oven door can be removed, by proceeding as follows (fig. 1-2):

- Open the door completely and lift the 2 levers "B" (fig.1);
- Now, shutting the door slightly, you can lift it out by pulling out the hooks "A" as shown in figure 2.

### Reattaching the Door

- With the door in a vertical position, insert the two hooks "A" into the slots;
- Ensure that seat "D" is hooked perfectly onto the edge of the slot (move the oven door backwards and forward slightly);
- Keep the oven door open fully, unhook the 2 levers "B" downwards and then shut the door again.

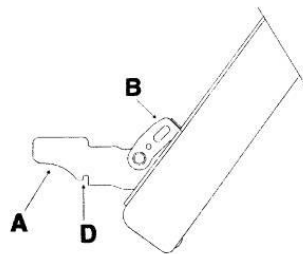

Fig 1

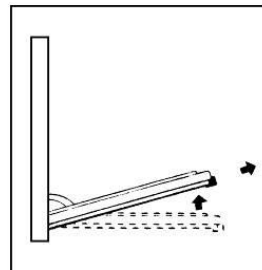

Fig 2

### Removing the Glass Panels

- Remove the oven door and place it on a piece of cloth or towel on a stable surface.
- Using one hand to push the glass from underneath and the other hand to pull it from above, remove the glass panels.

**Warning:** Scratches on the glass can lead to it shattering during use. Do not use tools which can cause scratches or abrasive or corrosive cleaning products to clean the glass.

# Maintenance and Cleaning

## Replacing the Oven Lamp

If the oven lamp fails, it must be replaced.

**Warning:** Disconnect the oven from the power source before replacing the lamp. Danger of electric shock.

- Disconnect the oven from the power source.
- Unscrew the glass cover by turning it anti-clockwise.
- Replace the lamp with an identical one.
- Screw the glass cover back on by turning it clockwise.
- Reconnect the power source.
- Test that the lamp works.

### Lamp Details

Voltage:	220-240VAC
Wattage:	25W
Socket:	G9
Temperature rating:	300°C

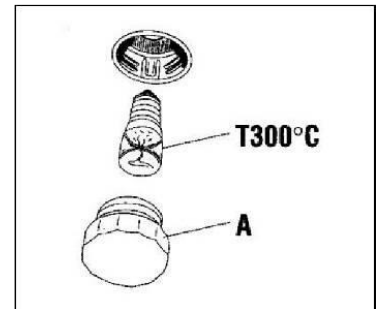

## Interior Wire Shelves

The two wire shelves come with a built-in safety feature to help minimise them being accidentally pulled fully out. This comes in the way of a "step", positioned part-way in from the rear of the accessory. To fit them into the oven, push the wire shelf part way into the oven until the step "catches", then angle the part over the step & fully insert. To remove, repeat the operation in reverse.

## Regular Inspections

Besides keeping the oven clean, you should:

- Carry out periodic inspections of the control elements and cooking units of the oven. After the guarantee has expired you should have a technical inspection of the oven carried out at a service centre at least once every two years.
- Fix any operational faults
- Carry out periodical maintenance of the cooking units of the oven.



**Caution:** Maintenance should only be done by a qualified technician.

## Troubleshooting

When first using your oven, it may emit a particular smell or some smoke. This is normal. Please refer to the 'Before Using the Oven for the First Time' section for instructions on how to properly start using your oven for the first time.

Use the below table to check for solutions if any faults occur. If none of the below is relevant to your issue, please contact support or a qualified technician.

Problem	Possible Reason	Suggestion
Oven isn't working.	Not connected to the power source.	Check that the oven is properly plugged in and switched on at the wall.
	Circuit breaker malfunction.	Reset the circuit breakers.
	Forgot to set the timer function.	Set the timer to the desired time, or to 'On' for no timer.
Lamp isn't turning on.	Lamp has blown.	Change for a new lamp.
Oven stops working during operation.	Power supply interrupted.	Check that your kitchen lights and other appliances are still working.
	Automatic thermal shutdown.	Check that the cooling fans are working.
Oven not heating.	Thermostat not set.	Set up the temperature.
	Forgot to set the timer.	Set the timer to the desired time, or to 'On' for no timer.
	Heating element damaged.	Change for a new heating element
Water leaks from the door during operation.	Door seal is damaged.	Replace the door seal.
	Door hinge is damaged.	Replace the door hinge.
Oven fans remain running after oven has finished cooking.	Oven needs to cool its working parts.	Put your hand to the outlet and feel for hot air. If yes, this is normal.
		If the air temperature from the outlet is room temperature, need to change for a new normal open thermostat.

# Warranty Certificate (New Zealand)

## Terms and Conditions

The following conditions apply in respect of the warranty given in this certificate:

1. Monaco Corporation Limited ("Monaco") warrants the following Robinhood products against manufacturing defects and faulty materials, under normal use and subject to the exclusions in this certificate, for a period of:
  - Rangehood, Ovens, Cooktops, Dishwashers, Refrigeration - 24 months from date of original purchase for domestic use.
  - Uniduct - 12 months from date of original purchase for domestic use.
  - Ironing centre - 12 months from date of original purchase for domestic use.
  - Sinks sets- 5 years on stainless steel sink including draining bench from date of original purchase for domestic use, 6 months on all stainless steel accessories, including wire rack, colander and tray from date of original purchase for domestic use.
  - Laundry Tub - 5 years on stainless bowl, 24 months on Tap, Cabinet and other components from the date of original purchase for domestic use.

"Original purchase", when used in this certificate, means purchase by the customer directly from Monaco or one of its approved suppliers.

2. This warranty is limited to the repair or replacement, at our option, within the warranty period of any component part which we at our discretion determine to contain faulty materials or a manufacturing defect in breach of this warranty. This warranty is subject to terms and conditions set out in this certificate.
3. The warranty only applies within New Zealand.
4. The customer must produce the original invoice or other purchase documentation as proof of the original purchase date.

## Warranty exclusions

1. The warranty does not apply where, in Monaco's opinion:
  - The defect is caused by misuse, wear and tear, dirt, fire or accidental damage. The product has been repaired or serviced by an unauthorised person.
  - The product was not installed in accordance with our instructions.
  - The product was purchased overseas or was not designed for use in New Zealand. The product was not used, cleaned or cared for in accordance with our instructions.
  - The product was used outdoors.
2. In addition, this warranty does not extend to damage or defects which in our opinion, directly or indirectly arise from or are due to:
  - Exposing the product to acidic or corrosive materials or chemicals such as dyes, solvents, denture cleaner or acetone; Using inappropriate household cleaning products such as abrasive cream or powder cleansers, furniture polish, bleach, mentholated spirits, drain cleaners, sugar soap, metal pads and strongly alkaline or acidic cleaners;
  - Heat damage, including from washing the product at high temperatures;
  - Impact or mishandling the product, including the impact caused by objects scraped along, thrown or dropped on the product surface or excessive weight being placed on the product;
  - Structural or support changes in or affecting the building or the application where the product has been installed;
  - Failure to clean or maintain the product as recommended; or any other causes specified in the product information as being excluded from this warranty.
3. Variations with the colour or gloss within the product or any ageing or fading of colour, shine or gloss level over time are not covered by this warranty. The warranty does not cover visual imperfections or blemishes in the surface and edges of the product that were not brought to your supplier's attention at the time you inspected the product.
4. Costs incurred on installation or removal of a product, or any reinstallation of a product, or any associated costs, are not covered by this warranty.
5. Monaco will not be liable for consequential or indirect loss or damage whatsoever and however arising out of or in connection with the supply, performance or removal of the product, including (but not limited to) loss of profit, loss of revenue, loss of contract, loss of goodwill or increased cost of workings, even if due to the negligence of Monaco or any of its approved suppliers, employees or agents.
6. Charcoal filters and light bulbs are not covered by this warranty
7. This warranty and the statements contained in this certificate or other documents given to you do not exclude, restrict or modify the application of any term implied into this warranty by statute, provided that (to the extent any statutory provision permits Monaco to limit its liability for a breach of an implied condition or warranty) Monaco's liability for such breach is limited to the payment of the cost of replacing the product, repairing the product or acquiring an equivalent product.
8. Subject to clause 5, our obligations under this warranty are limited to those set out in this certificate, and this warranty is expressly instead of all other warranties, express or implied, including any implied warranty of merchantability or fitness for a particular purpose and notwithstanding any course of dealing between the parties or custom and usage in trade to the contrary.

Terms and conditions are subject to change.

# Warranty Certificate (Australia)

## Terms and Conditions

If you are a consumer under the Australian Consumer Law, our goods come with guarantees that cannot be excluded under the Australian Consumer Law. You are entitled to a replacement or refund for a major failure and for compensation for any other reasonably foreseeable loss or damage. You are also entitled to have the goods repaired or replaced if the goods fail to be of acceptable quality and the failure does not amount to a major failure.

1. Shriro Australia Pty Limited ("Shriro") also warrants the following Robinhood products against manufacturing defects and faulty materials, under normal use and subject to the exclusions in this certificate, for a period of:
  - Rangehood, Ovens, Cooktops, Dishwashers, Refrigeration - 24 months from date of original purchase for domestic use.
  - Uniduct - 12 months from date of original purchase for domestic use.
  - Ironing centre - 12 months from date of original purchase for domestic use.
  - Sinks sets- 5 years on stainless steel sink including draining bench from date of original purchase for domestic use, 6 months on all stainless steel accessories, including wire rack, colander and tray from date of original purchase for domestic use.
  - Laundry Tub - 5 years on stainless bowl, 24 months on Tap, Cabinet and other components from the date of original purchase for domestic use. "Original purchase", when used in this certificate, means purchase by the customer directly from Shriro or one of its approved suppliers.
2. This warranty is limited to the repair or replacement, at our option, within the warranty period of any component part which we at our discretion determine to contain faulty materials or a manufacturing defect in breach of this warranty. This warranty is subject to terms and conditions set out in this certificate.
3. The warranty only applies within Australia.
4. For warranty service outside of capital city metropolitan area or 30 km from nearest authorised service agent you will be liable for reasonable travelling expenses and the cost of transport of the product or parts to and from the service agent
5. To make a claim under this warranty, you must produce the original invoice or other purchase documentation as proof of the original purchase date. You must send your claim to Shriro Australia Pty Limited, 104 Vanessa Street, Kingsgrove, NSW, 2208, within 7 days of any alleged defect or failure of the product first becoming apparent. You are responsible for the expense of making a claim under this warranty.

*This warranty is given by:*

Shriro Australia Pty Ltd, ABN: 28 002 386 129

Telephone: 1800 648 556

Facsimile: 1800 628 577

Email: [customercare@robinhood.com.au](mailto:customercare@robinhood.com.au)

[www.robinhood.com.au](http://www.robinhood.com.au)

Attention: Customer Services Manager

## Warranty exclusions

1. The warranty does not apply where, in Shriro's opinion:
  - The defect is caused by misuse, wear and tear, dirt, fire or accidental damage. The product has been repaired or serviced by an unauthorised person.
  - The product was not installed in accordance with our instructions.
  - The product was purchased overseas or was not designed for use in Australia.
  - The product was not used, cleaned or cared for in accordance with our instructions.
  - The product was used outdoors.
2. All Robinhood Rangehoods are suitable for indoor use only and not suitable over BBQs or charcoal cookers designed for outdoor use.
3. In addition, this warranty does not extend to damage or defects which in our opinion, directly or indirectly arise from or are due to: exposing the product to acidic or corrosive materials or chemicals such as dyes, solvents, denture cleaner or acetone; using inappropriate household cleaning products such as abrasive cream or powder cleansers, furniture polish, bleach, mentholated spirits, drain cleaners, sugar soap, metal pads and strongly alkaline or acidic cleaners; heat damage, including from washing the product at high temperatures; impact or mishandling the product, including the impact caused by objects scraped along, thrown or dropped on the product surface or excessive weight being placed on the product; structural or support changes in or affecting the building or the application where the product has been installed; failure to clean or maintain the product as recommended; or any other causes specified in the product information as being excluded from this warranty.
4. Variations with the colour or gloss within the product or any ageing or fading of colour, shine or gloss level over time are not covered by this warranty. The warranty does not cover visual imperfections or blemishes in the surface and edges of the product that were not brought to your supplier's attention at the time you inspected the product.
5. We will not be responsible under this warranty for, nor pay the costs of, removing the existing product, or reinstalling the new product, or any associated costs or damages.
6. Charcoal filters and light bulbs are not covered by this warranty.

The benefits given by this warranty are in addition to other rights and remedies of consumers under any law in relation to the goods which cannot be excluded.

This warranty certificate is not intended to create a contract between Shriro Australia Pty Limited and the purchaser.

### New Zealand

Monaco Corporation Ltd

Telephone: (09) 415 6000

Facsimile: (09) 415 7400

Email: [customercare@robinhood.co.nz](mailto:customercare@robinhood.co.nz)

[www.robinhood.co.nz](http://www.robinhood.co.nz)

### Australia

Shriro Australia Pty Ltd

ABN 28 002 386 129

Telephone: 1800 648 556

Facsimile: 1800 628 577

Email: [customercare@robinhood.com.au](mailto:customercare@robinhood.com.au)

[www.robinhood.com.au](http://www.robinhood.com.au)

IM Ref: OBD605K70B IM 28/2021/10FC

