

HEF302TCOM

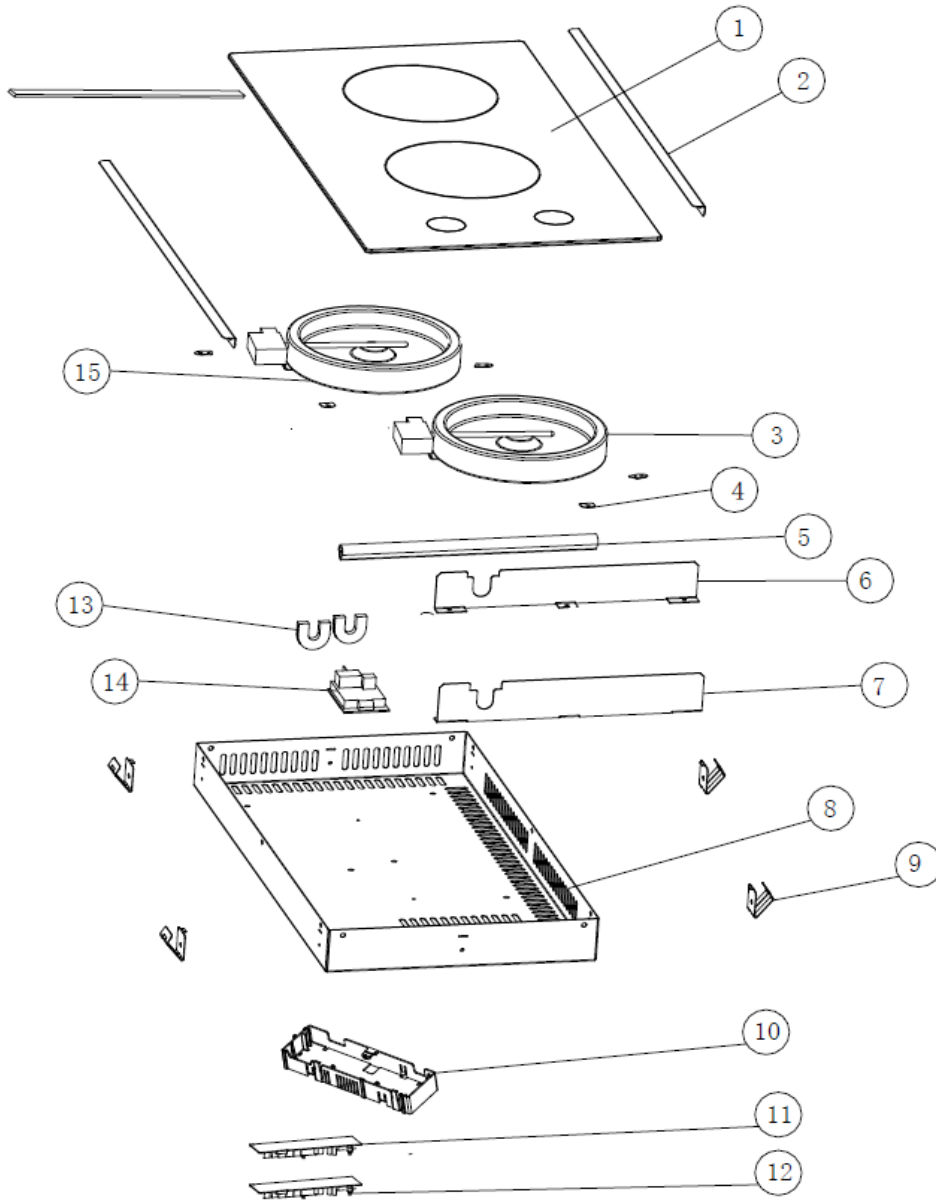

SEQ	PART NO.	QTY (in Product)	DESCRIPTION
1	303070100180	1	GLASS CERAMIC PANEL
2	303010300001	2	L-SHAPED GLASS BRACKET
3	303050300016	1	SINGLE RING PLATE (1200W)
4	303010300021	6	PLATE BLOCK
5	303040200004	1	SILICONE STRIP
6	303010200015	1	HEAT SHIELD 1
7	303010200016	1	HEAT SHIELD 2
8	303010100010	1	BOTTOM CASE
9	303010300021	4	BUCKLE
10	303040100001	1	MOUNTING FRAME FOR THE PCB BOARD
11	290030100022	1	PCB BOARD
12	290030200023	1	DISPLAY
13	303040200002	2	U-SHAPED SILICONE RING
14	303050600001	1	TERMINAL BOX
15	303050300013	1	DOUBLE RING PLATE (1700W)