

Description: **ROBINHOOD 60CM CERAMIC COOKTOP WHITE**

Model Number: **HEC604KWH**



# Contents

## Congratulations!

Thank you for choosing one of our appliances. Before you use the appliance, we strongly recommend that you read through the whole user manual which provides important safety instructions and description of the product and the proper use of its functions.

To avoid the ever-present risks involved with using an electrical appliance it is vital that the oven is installed correctly and that you read the safety instructions carefully to avoid misuse and hazards. It is important that you retain these instructions and your proof of purchase along with any other important documents about this product for future reference.

Due to continual product development, Robinhood reserves the right to alter specifications or appearances without notice.

Important Safety Instructions.....	1
Product Information .....	2
Installation.....	3
Operating Instructions.....	4
Maintenance and Cleaning.....	5
Warranty Certificate (New Zealand).....	6
Warranty Certificate (Australia) .....	7

## Disposal Information

- Most of the packing materials are recyclable. Please dispose of these materials through your local recycling depot or by placing them in appropriate collection containers.
- If you wish to discard this product, please contact your local authorities and ask for the correct method of disposal.

# Important Safety Instructions

**IMPORTANT:** Read the assembly instruction section and safety precautions of this booklet carefully before removing the contents of this carton.

1. This appliance is not intended for use by persons (including children) with reduced physical, sensory or mental capabilities, or lack of experience or knowledge, unless they have been given supervision or instruction concerning the use of the appliance by a person responsible for their safety. Children should be supervised to ensure that they do not play with the appliance.
2. After removing the packaging, make sure to check if there is any damage to the appliance. If there is any damage (including cracked glass), never attempt to use the appliance and immediately contact your Authorised Service Centre. As packaging materials can be dangerous to children, they need to be collected immediately and put out of reach.
3. In certain circumstances electrical appliances may be a danger hazard. Check the conformity of voltage and power settings, which are specified on the information plate attached to the appliance and/or packaging, with the usage conditions available.
4. Do not place heavy objects in or on these appliances, use for storage or as a cutting surface. This appliance is designed for cooking food only. Use flat based, stable cooking pots only.
5. This appliance is designed for domestic household use only and for the cooking of domestic food products. Use as a commercial appliance will void the warranty. It should not to be used in a marine environment or outdoors and must be fully built in. Do not use the appliances until fully installed.
6. A means for disconnection must be incorporated in the fixed wiring in accordance with the wiring rules.
7. The electrical connection must be accessible after installation. The appliance must be electrically isolated before any maintenance can be performed.
8. The appliance is not intended to be operated by means of an external timer or separate remote control system.
9. Electrical connection must be made as per local wiring rules and regulations. Do not disconnect the appliance with wet hands or bare feet, and do not disconnect the power cord with extreme force.
10. Ensure that the kitchen is well ventilated or mechanical ventilation is in use while cooking on this appliance.
11. Do not store or use flammable materials or aerosols near the cooktop. Items made from aluminium, plastic or plastic film should also be kept away from the appliance, as they may fuse to the surface.
12. **WARNING** – The surface temperature of this appliance exceeds 95°C. To avoid a hazard, under bench access must be restricted. Aboard must be installed underneath the cooktop.
13. **WARNING** - The cooktop will become hot during and directly after use. Do not touch the surface during this time, as it may be hot and can cause burns. To avoid burns, children should be kept away.
14. Cleaning may only be commenced on the appliance once it has cooled down and is turned off. Do not use a steam jet or any other high pressure cleaning equipment to clean the appliance.
15. When the appliance is not being used, turn the appliance off.
16. Where this appliance is installed in a caravan, it shall NOT be used as a space heater.
17. Do not modify this appliance.
18. Do not use harsh abrasive cleaners or sharp metal scrapers to clean the glass surface as they can scratch the surface, which may result in the glass shattering. Clean the glass using a warm damp cloth (e.g. dishcloth) and dry it with a soft dry tea towel.
19. All cabinetry and materials used in the installation must be able to withstand a minimum temperature of 100°C above the ambient temperature of the room it is located in, whilst in use. Certain types of vinyl or laminate kitchen furniture are particularly prone to heat damage or discolouration at temperatures below the guidelines given above. Any damage caused by the appliance being installed without adhering to the temperature limits set out above will be the liability of the owner. To avoid any hazards, limit access to the under-bench section of the cooktop.
20. The appliance must be installed and put into operation by an authorised technician under the conditions provided by the manufacturer in this manual. The manufacturer cannot be held responsible for any damage that might occur due to faulty installation.
21. Damage can occur to bench tops if pots and pans are allowed to overlap the bench top. This can result in heat being transferred to the bench top. Ensure that correct sized pots & pans are used. Cast iron and cast aluminium cookware with damaged bases may scratch the cooktop surface if they are dragged across it. Pans should be lifted on and off the cooktop surface and not dragged. Cooking zones should not be switched on without cookware placed on it. Also the cookware should not be empty for any length of time.
22. If any cracking is noticed on the vitro-ceramic cooktop, turn the appliance off immediately and call your Authorised Service Centre.
23. Do not leave the cooktop while cooking with solid or liquid oils. There may be flaming up in conditions of extreme heating.
24. Never pour water onto the flames occurring from oil. Immediately turn the cooktop off and cover the pan with a lid or fire blanket in order to smother the flame.
25. The ceramic cooker hob must be installed by qualified personnel or technicians. We have professionals at your service. Please never conduct the operation by yourself.
26. The ceramic cooker hob shall not be mounted to cooling equipment, dishwashers and rotary dryers.
27. The ceramic cooker hob shall be installed such that better heat radiation can be ensured to enhance its reliability.
28. The wall and induced heating zone above the work surface shall withstand heat.
29. To avoid any damage, the sandwich layer and adhesive must be resistant to heat.
30. A steam cleaner is not to be used.

## Product Information

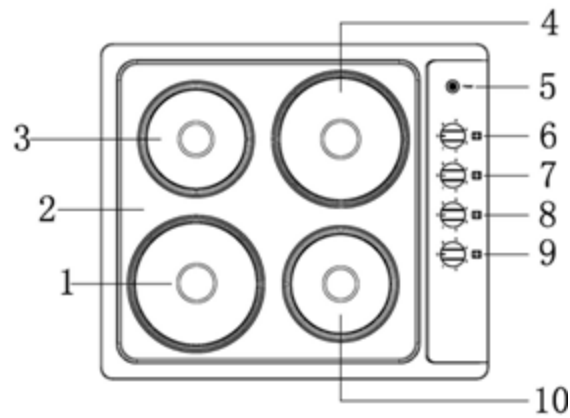

- |                                |                                  |
|--------------------------------|----------------------------------|
| 1. Front left hotplate, Ø180mm | 6. Rear left hotplate control    |
| 2. Panel                       | 7. Rear right hotplate control   |
| 3. Rear left hotplate, Ø145mm  | 8. Front right hotplate control  |
| 4. Rear right hotplate, Ø180mm | 9. Front left hotplate control   |
| 5. Power indicator             | 10. Front right hotplate, Ø145mm |

Model	HEC604KWH
Cooking Zones	4
Supply Voltage	220 - 240VAC ~50Hz
Rated Power	5000W

## Technical Information

### Cooking Zones

Front left:	180, 1 x 1.5 kW solid hot plate
Rear left:	145, 1 x 1.0 kW solid hot plate
Rear right:	180, 1 x 1.5 kW solid hot plate
Front right:	145, 1 x 1.0 kW solid hot plate
Total power:	5.0kW

# Installation

The kitchen area should be dry and aired and equipped with efficient ventilation. When installing the cooktop, easy access to all control elements should be ensured.

This is a built-in ceramic, which means that its back wall and one side wall can be placed next to a high piece of furniture or a wall. Coating or veneer used on fitted furniture must be applied with a heat-resistant adhesive (100°C). This prevents surface deformation or detachment.

A rangehood should be installed at a minimum height of 650mm above the surface of the cooktop, or, if a different value is specified by the manufacturer of the rangehood, the greater of the two values.

## Assembly

- Cut an opening in the benchtop according to the dimensions in the figure below.
- Check seal for perfect fit and overall cover. Lower the electric hob into place and align correctly.
- Using a standard screwdriver, tighten the tension clamps evenly starting at the centre and moving diagonal, until the built-in rim is tight on the worktop.

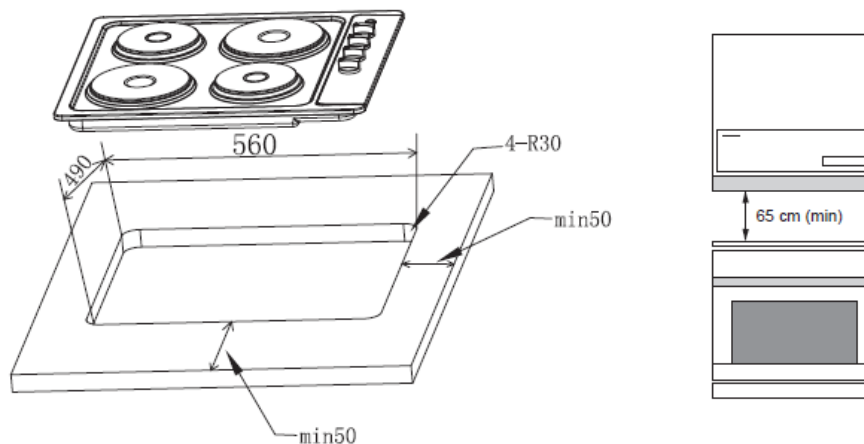

## Electrical Installation

**Note:** This appliance must be installed by a qualified electrician.

**Supply connection:** 30A (Double pole switched fused outlet with 3mm contact gap).

If the mains supply cable is damaged, then it must be replaced by an appropriate replacement. The mains supply cable should be replaced in accordance with the following instructions:

- Switch the appliance off at the control switch.
- Open the terminal block on the underside of the hob.
- Unscrew the terminal screws fixing the cable.
- The "green-yellow" earth wire must be connected to the terminal marked  $\perp$ . It must be about 10 mm longer than the live and neutral wires.
- The "blue" neutral wire must be connected to the terminal marked with letter (N) - the live wire must be connected to the terminal marked with letter (L).

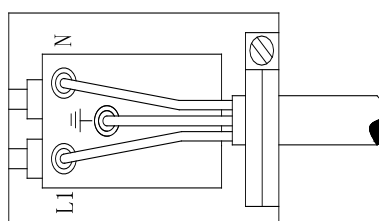

# Operating Instructions

The heat level can be adjusted gradually by turning the appropriate knob to the left or right. When the cooktop is in use, the power indicator light will be on.

## Heat Level Selection

- 0 Switch off
- 1 Min. Warming up
- 2 Stewing vegetables, slow cooking
- 3 Cooking soups, larger dishes
- 4 Slow frying
- 5 Grilling meat, fish
- 6 Max. Fast heating up, fast cooking, frying

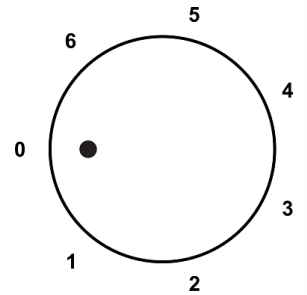

The cooktop panel can be cleaned using washing liquids or gentle liquid scrubbing agents and wiped dry.

The surface of the hotplates should be regularly polished with white mineral oil or silicone oil. Do not use animal or vegetable fats like butter, lard, oil, etc. for this.

The hotplate should be cleaned using warm water with a bit of washing liquid. Larger stains can be removed using gentle scrubbing liquids.

An appropriately selected pan saves energy. A pan should have a thick, flat base with a diameter equal to the hotplate diameter as in that case is transferred most efficiently.



wrong



wrong

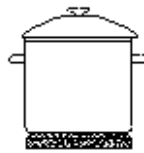

right

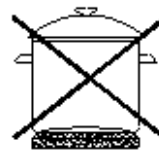

wrong

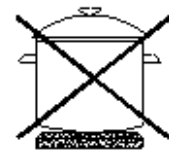

wrong

**WARNING:** Unattended cooking on a hob with fat or oil can be dangerous and may result in a fire.

## Maintenance and Cleaning



**Caution:**

All repairs and regulatory activities should be carried out by the appropriate service centre or by an appropriately authorized fitter.

If your appliance appears not to be operating correctly, please contact the supplier.

**DO NOT ATTEMPT TO REPAIR THE APPLIANCE YOURSELF.**

**Warning:** Before performing any cleaning or maintenance, ensure that the cooktop is switched off and disconnected from the power source.

**Warning:** Ensure that the cooktop is cool before performing any cleaning or maintenance.

Ensure that you regularly clean the cooktop. Use a soft, warm, damp cloth with some washing detergent. Avoid scratching the hotplates. Heavy duty scourers, some nylon scourers and harsh / abrasive agents may scratch the surface. Always read the label of your cleaning agent or scourer before use.

Make sure that you wipe dry the control panel before turning the cooktop back on.

# Warranty Certificate (New Zealand)

## Terms and Conditions

The following conditions apply in respect of the warranty given in this certificate:

1. Monaco Corporation Limited ("Monaco") warrants the following Robinhood products against manufacturing defects and faulty materials, under normal use and subject to the exclusions in this certificate, for a period of:
  - Rangehood, Ovens, Cooktops, Dishwashers, Refrigeration - 24 months from date of original purchase for domestic use.
  - Uniduct - 12 months from date of original purchase for domestic use.
  - Ironing centre - 12 months from date of original purchase for domestic use.
  - Sinks sets- 5 years on stainless steel sink including draining bench from date of original purchase for domestic use, 6 months on all stainless steel accessories, including wire rack, colander and tray from date of original purchase for domestic use.
  - Laundry Tub - 5 years on stainless bowl, 24 months on Tap, Cabinet and other components from the date of original purchase for domestic use.

"Original purchase", when used in this certificate, means purchase by the customer directly from Monaco or one of its approved suppliers.

2. This warranty is limited to the repair or replacement, at our option, within the warranty period of any component part which we at our discretion determine to contain faulty materials or a manufacturing defect in breach of this warranty. This warranty is subject to terms and conditions set out in this certificate.
3. The warranty only applies within New Zealand.
4. The customer must produce the original invoice or other purchase documentation as proof of the original purchase date.

## Warranty exclusions

1. The warranty does not apply where, in Monaco's opinion:
  - The defect is caused by misuse, wear and tear, dirt, fire or accidental damage. The product has been repaired or serviced by an unauthorised person.
  - The product was not installed in accordance with our instructions.
  - The product was purchased overseas or was not designed for use in New Zealand. The product was not used, cleaned or cared for in accordance with our instructions.
  - The product was used outdoors.
2. In addition, this warranty does not extend to damage or defects which in our opinion, directly or indirectly arise from or are due to:
  - Exposing the product to acidic or corrosive materials or chemicals such as dyes, solvents, denture cleaner or acetone; Using inappropriate household cleaning products such as abrasive cream or powder cleansers, furniture polish, bleach, mentholated spirits, drain cleaners, sugar soap, metal pads and strongly alkaline or acidic cleaners;
  - Heat damage, including from washing the product at high temperatures;
  - Impact or mishandling the product, including the impact caused by objects scraped along, thrown or dropped on the product surface or excessive weight being placed on the product;
  - Structural or support changes in or affecting the building or the application where the product has been installed;
  - Failure to clean or maintain the product as recommended; or any other causes specified in the product information as being excluded from this warranty.
3. Variations with the colour or gloss within the product or any ageing or fading of colour, shine or gloss level over time are not covered by this warranty. The warranty does not cover visual imperfections or blemishes in the surface and edges of the product that were not brought to your supplier's attention at the time you inspected the product.
4. Costs incurred on installation or removal of a product, or any reinstallation of a product, or any associated costs, are not covered by this warranty.
5. Monaco will not be liable for consequential or indirect loss or damage whatsoever and however arising out of or in connection with the supply, performance or removal of the product, including (but not limited to) loss of profit, loss of revenue, loss of contract, loss of goodwill or increased cost of workings, even if due to the negligence of Monaco or any of its approved suppliers, employees or agents.
6. Charcoal filters and light bulbs are not covered by this warranty
7. This warranty and the statements contained in this certificate or other documents given to you do not exclude, restrict or modify the application of any term implied into this warranty by statute, provided that (to the extent any statutory provision permits Monaco to limit its liability for a breach of an implied condition or warranty) Monaco's liability for such breach is limited to the payment of the cost of replacing the product, repairing the product or acquiring an equivalent product.
8. Subject to clause 5, our obligations under this warranty are limited to those set out in this certificate, and this warranty is expressly instead of all other warranties, express or implied, including any implied warranty of merchantability or fitness for a particular purpose and notwithstanding any course of dealing between the parties or custom and usage in trade to the contrary.

Terms and conditions are subject to change.



# Warranty Certificate (Australia)

## Terms and Conditions

If you are a consumer under the Australian Consumer Law, our goods come with guarantees that cannot be excluded under the Australian Consumer Law. You are entitled to a replacement or refund for a major failure and for compensation for any other reasonably foreseeable loss or damage. You are also entitled to have the goods repaired or replaced if the goods fail to be of acceptable quality and the failure does not amount to a major failure.

1. Shriro Australia Pty Limited ("Shriro") also warrants the following Robinhood products against manufacturing defects and faulty materials, under normal use and subject to the exclusions in this certificate, for a period of:
  - Rangehood, Ovens, Cooktops, Dishwashers, Refrigeration - 24 months from date of original purchase for domestic use.
  - Uniduct - 12 months from date of original purchase for domestic use.
  - Ironing centre - 12 months from date of original purchase for domestic use.
  - Sinks sets- 5 years on stainless steel sink including draining bench from date of original purchase for domestic use, 6 months on all stainless steel accessories, including wire rack, colander and tray from date of original purchase for domestic use.
  - Laundry Tub - 5 years on stainless bowl, 24 months on Tap, Cabinet and other components from the date of original purchase for domestic use. "Original purchase", when used in this certificate, means purchase by the customer directly from Shriro or one of its approved suppliers.
2. This warranty is limited to the repair or replacement, at our option, within the warranty period of any component part which we at our discretion determine to contain faulty materials or a manufacturing defect in breach of this warranty. This warranty is subject to terms and conditions set out in this certificate.
3. The warranty only applies within Australia.
4. For warranty service outside of capital city metropolitan area or 30 km from nearest authorised service agent you will be liable for reasonable travelling expenses and the cost of transport of the product or parts to and from the service agent
5. To make a claim under this warranty, you must produce the original invoice or other purchase documentation as proof of the original purchase date. You must send your claim to Shriro Australia Pty Limited, 104 Vanessa Street, Kingsgrove, NSW, 2208, within 7 days of any alleged defect or failure of the product first becoming apparent. You are responsible for the expense of making a claim under this warranty.

*This warranty is given by:*

Shriro Australia Pty Ltd, ABN: 28 002 386 129  
Telephone: 1800 648 556  
Facsimile: 1800 628 577  
Email: [customercare@robinhood.com.au](mailto:customercare@robinhood.com.au)  
[www.robinhood.com.au](http://www.robinhood.com.au)  
Attention: Customer Services Manager

## Warranty exclusions

1. The warranty does not apply where, in Shriro's opinion:
  - The defect is caused by misuse, wear and tear, dirt, fire or accidental damage. The product has been repaired or serviced by an unauthorised person.
  - The product was not installed in accordance with our instructions.
  - The product was purchased overseas or was not designed for use in Australia.
  - The product was not used, cleaned or cared for in accordance with our instructions.
  - The product was used outdoors.
2. All Robinhood Rangehoods are suitable for indoor use only and not suitable over BBQs or charcoal cookers designed for outdoor use.
3. In addition, this warranty does not extend to damage or defects which in our opinion, directly or indirectly arise from or are due to: exposing the product to acidic or corrosive materials or chemicals such as dyes, solvents, denture cleaner or acetone; using inappropriate household cleaning products such as abrasive cream or powder cleansers, furniture polish, bleach, mentholated spirits, drain cleaners, sugar soap, metal pads and strongly alkaline or acidic cleaners; heat damage, including from washing the product at high temperatures; impact or mishandling the product, including the impact caused by objects scraped along, thrown or dropped on the product surface or excessive weight being placed on the product; structural or support changes in or affecting the building or the application where the product has been installed; failure to clean or maintain the product as recommended; or any other causes specified in the product information as being excluded from this warranty.
4. Variations with the colour or gloss within the product or any ageing or fading of colour, shine or gloss level over time are not covered by this warranty. The warranty does not cover visual imperfections or blemishes in the surface and edges of the product that were not brought to your supplier's attention at the time you inspected the product.
5. We will not be responsible under this warranty for, nor pay the costs of, removing the existing product, or reinstalling the new product, or any associated costs or damages.
6. Charcoal filters and light bulbs are not covered by this warranty.

The benefits given by this warranty are in addition to other rights and remedies of consumers under any law in relation to the goods which cannot be excluded.

This warranty certificate is not intended to create a contract between Shriro Australia Pty Limited and the purchaser.

### New Zealand

Monaco Corporation Ltd  
Telephone: (09) 415 6000  
Facsimile: (09) 415 7400  
Email: [customercare@robinhood.co.nz](mailto:customercare@robinhood.co.nz)  
[www.robinhood.co.nz](http://www.robinhood.co.nz)

### Australia

Shriro Australia Pty Ltd  
ABN 28 002 386 129  
Telephone: 1800 648 556  
Facsimile: 1800 628 577  
Email: [customercare@robinhood.com.au](mailto:customercare@robinhood.com.au)  
[www.robinhood.com.au](http://www.robinhood.com.au)