

Description: **Robinhood 60cm ceramic standard electric hob with knob controls**

Model Numbers: **HEAB604FKG**

Typical design



Dimensions

Cooktop size	
Width	580mm
Depth	510mm
Height	50mm
Cut out width	560mm
Cut out depth	490mm

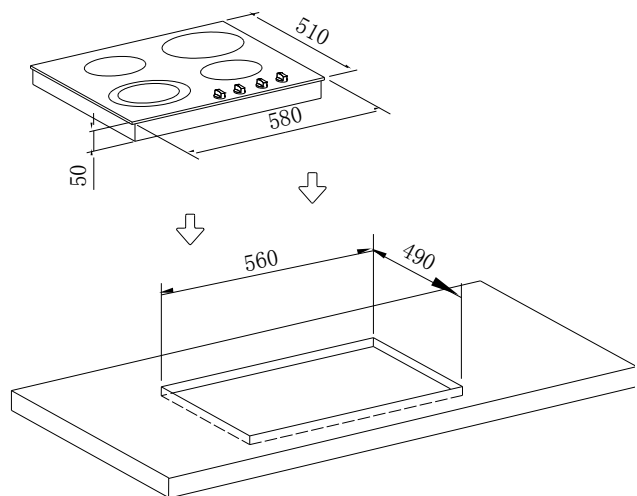

Specifications

Electrical Approval: App: NSW27102
Electrical Standard: AS/NZS 60335.2.6:2008 inc, amendment 1,2 & 3

Electrical specifications

Voltage: 220-240V 50hz
Cook Top wattage: 6000W

Right hand front radiant heating element: 160mm diameter, 1200W
Right hand rear radiant heating element: 200mm diameter, 1800W
Left hand front radiant heating element: 200mm diameter, 1800W
Left hand rear radiant heating element: 160mm diameter, 1200W

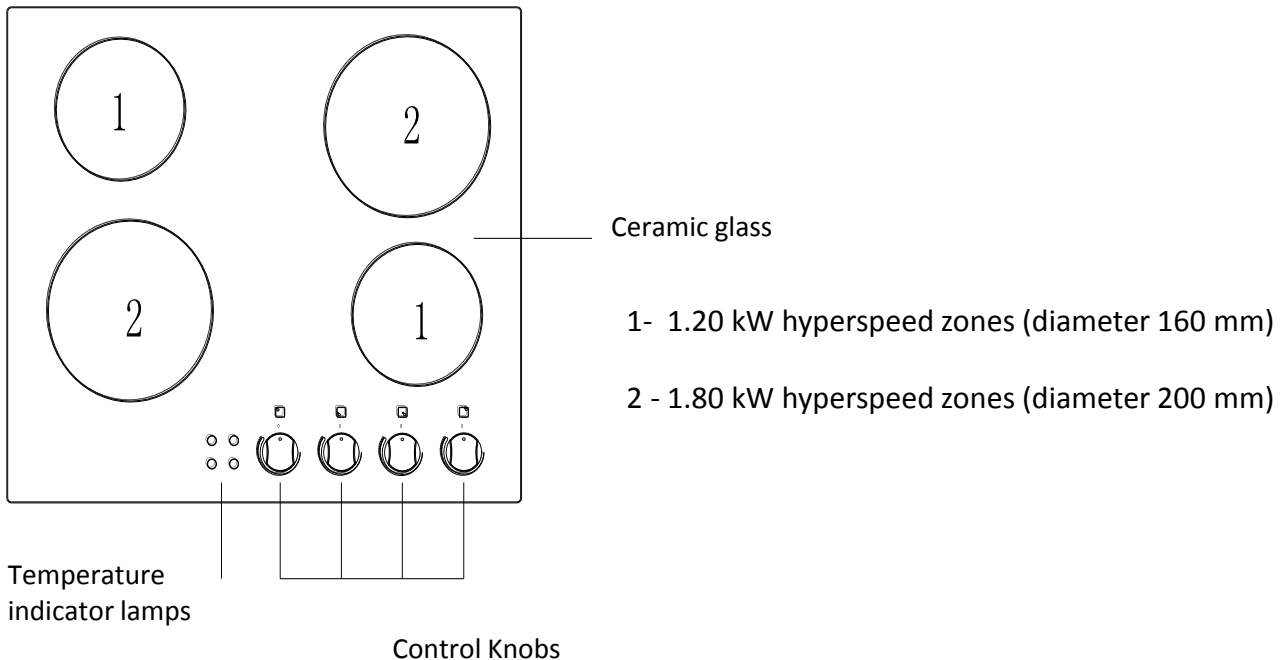

Gross weight: 9.9kg
Nett weight: 8kg
Carton volume: 0.053m³
Carton dimensions: 680mm x 595mm x 131mm

New Zealand

Monaco Corporation Ltd
Telephone: (09) 415 6000
Facsimile: (09) 415 7400
Email: enquiries@robinhood.co.nz
www.robinhood.co.nz

Australia

Shriro Australia Pty Ltd
ABN 28 002 386 129
Telephone: 1800 648 556
Facsimile: 1800 628 577
Email: enquiries@robinhood.com.au
www.robinhood.com.au