

Identifying your American Classic Hub

American Classic Rear Hub - 15mm axle or 17mm axle

(A) 15mm hub

This hub uses four 15267 fully sealed bearings.

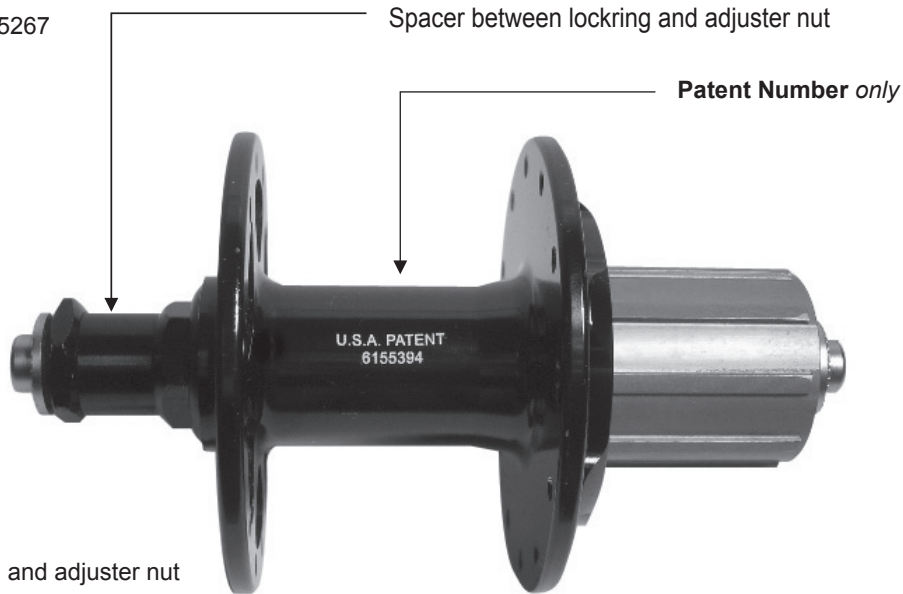

Identifiers Include:

Patent Number *only*
Spacer between locking and adjuster nut

(B) 17mm hub

This hub uses four 6803 C3 fully sealed bearings. Two in the hub shell and two in the free hub body.

Stainless steel standard,
Ceramic available as
an upgrade.

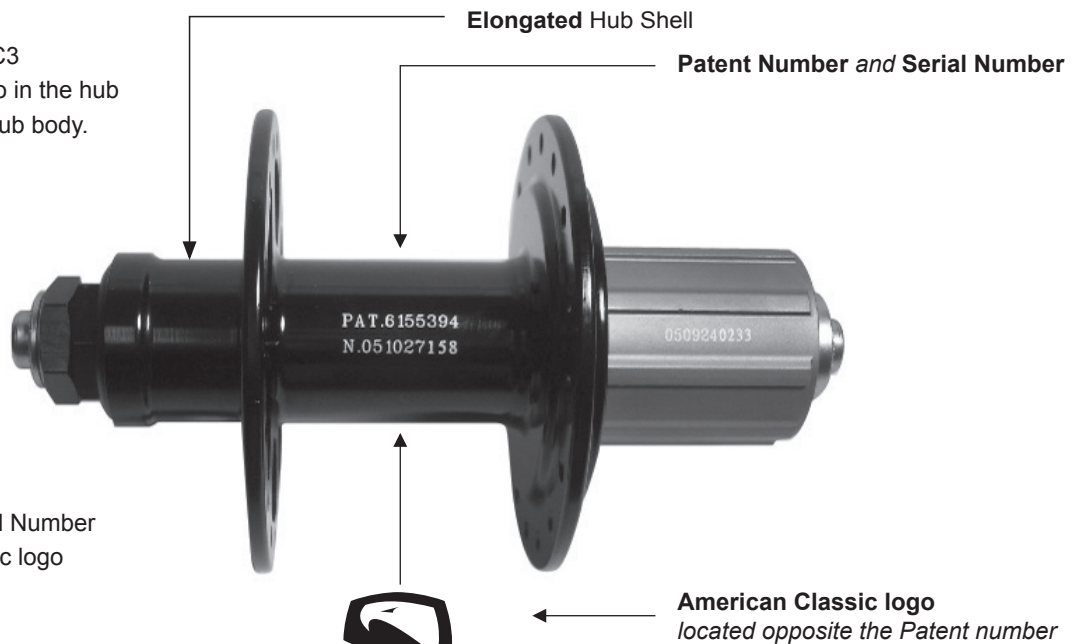

Identifiers include:

Patent Number *and* Serial Number
Two Line American Classic logo
Elongated hub shell.



All repairs should be performed by a Professional Bicycle Mechanic.