

MTB Disc Syntace X12 Thru-Axle Retrofit Page 1

Making Your MTB Disc Hub Syntace X12 Thru-Axle Compatible.

- Syntace X12 142mm x 12mm Thru-Axle, is compatible with the Disc 225 17mm axle hub only. Please make sure you are working with a 17mm Disc 225 hub before attempting retrofit. See manual: "Rear Cassette Hub: Which Do I Have?" at www.amclassic.com
- **Tools Needed:** Two 19mm cone wrenches, 135mm quick release, axle vise or smooth clamp.
- **While disassembling the hub, keep all loose parts organized on a clean rag or paper towel. Do NOT modify or bend the cassette body loop spring in any way. Proper re-assembly is important to rider safety.**

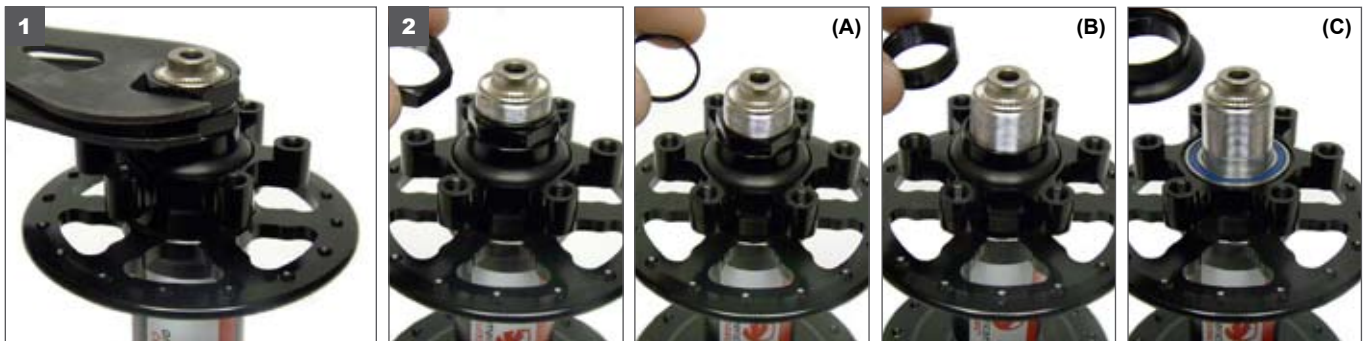

1. Using two 19mm cone wrenches, loosen the lock and adjusting nut. 2. Remove lock nut. A. Some hubs have a 1.5mm axle spacer. B. Remove adjuster nut. C. Remove spacer with attached dust seal.

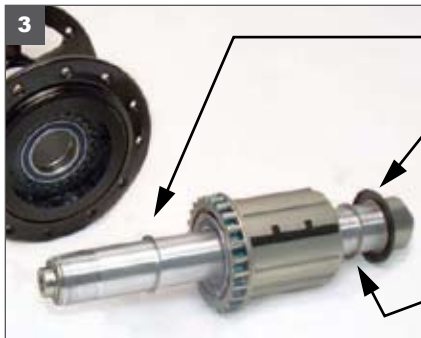

Very Important!
 Locate the 0.5mm axle spacer, which is either stuck to the drive side hub shell bearing or the inner bearing on the cassette body. This spacer is critical to maintaining the correct engagement, do not lose!
 Reuse the dust seal.
 Do not reuse 0.5mm axle spacer.



3. Separate cassette body and axle from the hub shell by grabbing the body and pulling out from the drive side. 4. Remove large black pawl seal.

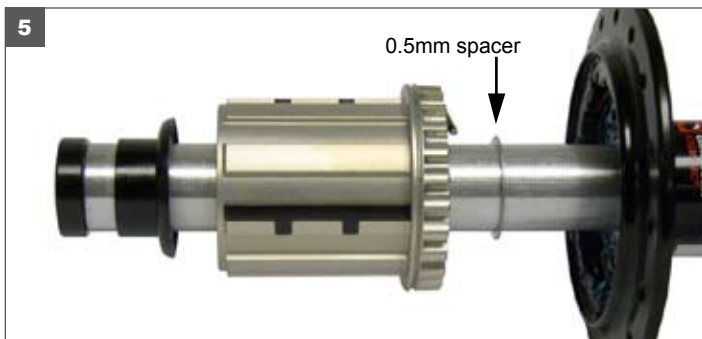

5. Syntace X12 Axle Assembly

With a thin layer of clean grease coating the cassette body teeth, join the axle, cassette body and spacers with the hub shell.

Order: End Cap > Spacer with Dust Seal > Shimano cassette body > 0.5mm spacer > Hub shell.

Continue to Page 2.

MTB Disc Syntace X12 Thru-Axle Retrofit Page 2

Making Your MTB Disc Hub Syntace X12 Thru-Axle Compatible.



Very Important:

6. The large black Pawl Seal **MUST** be installed after the cassette body and axle have been joined with the hub shell.

With the axle pushed completely into the hub shell and pawls engaged with the cassette body, install the large black pawl seal.

NOTE: After completing Step 6, be sure the seal is securely in the groove on the cassette body and you can rotate the body freely without the seal moving.

A bit of Tri-Flow® or similar lubricant will help with friction between the groove in the body and this seal.

Final Hub Assembly:

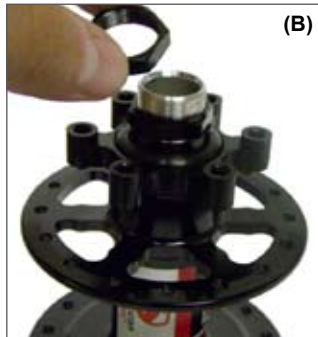

7. Grease the threads and install the spacer with dust seal. (A) Finger tighten the adjusting nut with the shoulder side facing the hub shell. (B) Install the lock nut and finger tighten. (C) Using two 19mm cone wrenches, remove all play on adjusting nut, then back off one half rotation, 180 degrees.



8. Make sure the lock nut is fully threaded onto the axle and place threadless end cap on axle.



9. Pressing in the end cap.

Place a quick release through the axle with the lever on the drive side. Tighten quick release and clamp down, the end cap will partially press into the axle. Continue to tighten the quick release and clamp down until the end cap is fully pressed into the axle.

Continue to Page 3.

MTB Disc Syntace X12 Thru-Axle Retrofit Page 3

Making Your MTB Disc Hub Syntace X12 Thru-Axle Compatible.

Final Bearing Adjustment In Frame:

The purpose of adjustability is to extend the life of your bearings, reduce friction and rolling resistance to boost performance. The desired adjustment for American Classic hubs is described as “slightly more than no play” as to not overload the bearings. Some play will be removed with the clamping action of your quick release. Be sure the two outer dust seals on each end of the axle are covering the bearings completely. This adjustment is the same for road and mountain wheel sets.



10. Place the wheel in the frame and clamp down quick release. Hold the adjusting nut in place with a 19mm cone wrench, still one half rotation loose from Step 7, tighten the lock nut against the adjusting nut. Once the lock nut is tight, check for the desired adjustment by wiggling the tire at the rim to feel for “slightly more than no play.” If the adjustment is not correct continue to Step 10.



11. Hold the adjusting nut in place and loosen the lock nut. Slightly tighten or loosen the adjusting nut and hold in place. With the adjusting nut in place, tighten down the lock nut. Wiggle rim. Repeat Step 11 until the desired adjustment is achieved. Make sure the lock nut is tightened down when finished.

Removing Syntace X12 Axle:



Removing the end cap. Using a smooth clamp to hold the drive side end cap, loosen the lock nut with a 19mm cone wrench. The lock nut will push the non-drive side end cap free from the axle.



Once the end cap is free from the axle follow the overhaul document: “MTB Disc Hub 17mm – Overhaul/Bearing Change” at www.amclassic.com to put the quick release axle back in.