



AMERICAN CLASSIC

A CLASSIC IS REBORN

BICYCLE TIRE RANGE 2022

AMCLASSIC.COM

AMERICAN CLASSIC AND INNOVATION



American Classic exemplifies the pinnacle of performance bicycle engineering and innovation. In 1982, Bill Shook, the founder of American Classic left the beaten path to seek new and innovative ways to improve bicycle technology with the single-minded purpose of making bicycle sport enjoyable for all.

A global search for the finest production facility led American Classic to start its own manufacturing in 1996. The singular focus on every product detail fast-tracked American Classic to become a leader in the aftermarket.

Now American Classic is back with a complete line of tire products. Through its research and development in rubber technology, American Classic can once again push forward its innovation that exceeds all expectations.

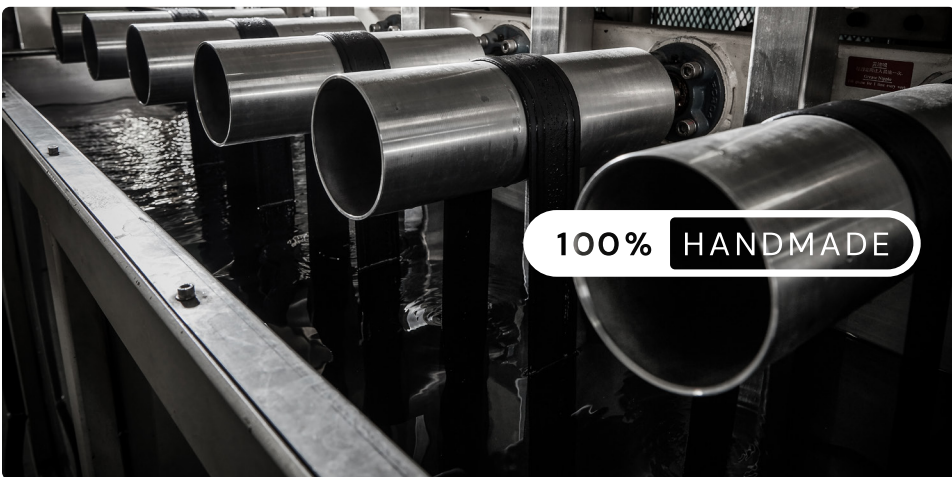

100% HANDMADE





TUBE TYPE

TUBELESS READY

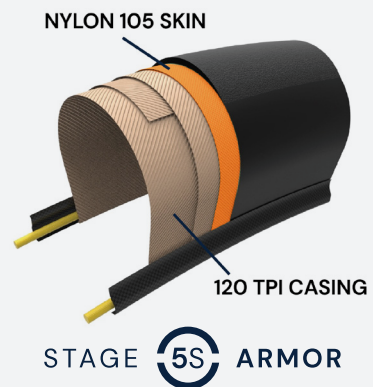
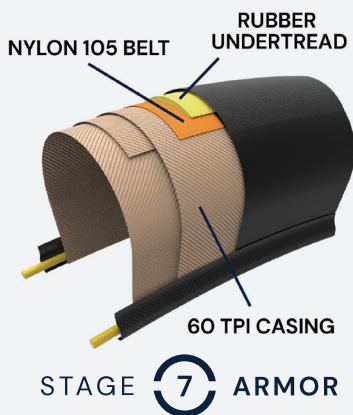
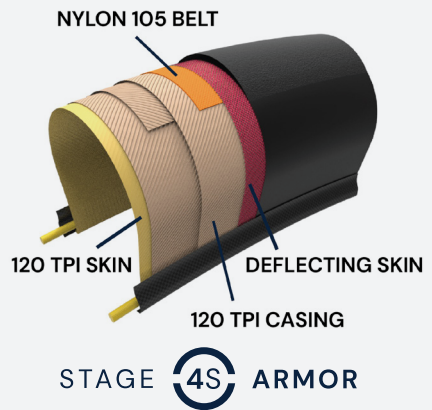
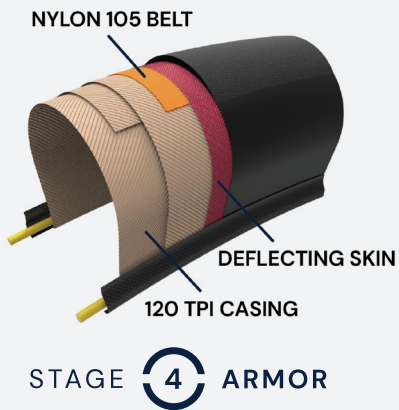
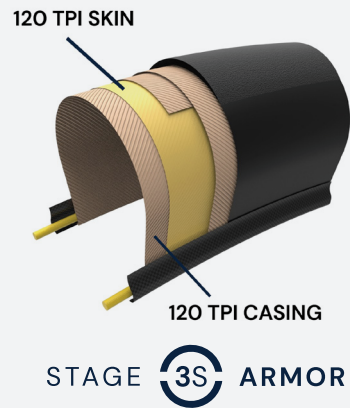
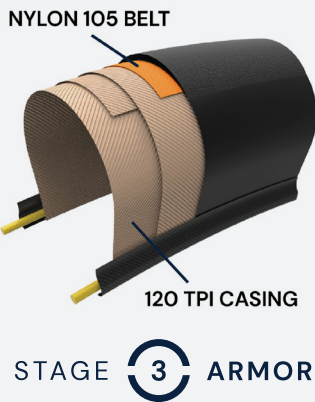



TIMEKEEPER

ROAD PERFORMANCE

TORCHBEARER

ALL-WEATHER ROAD



TUBE TYPE

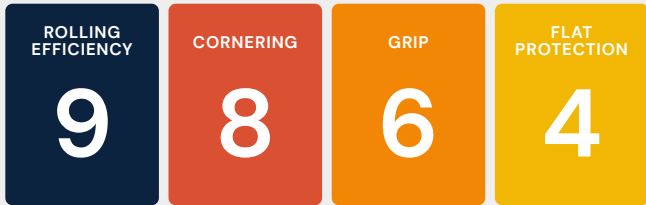

TUBE TYPE

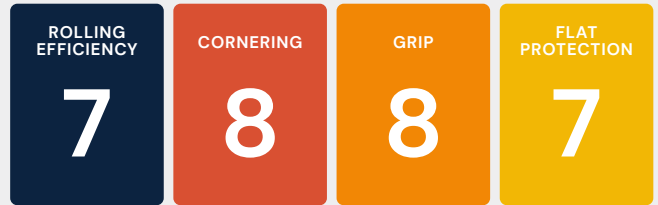

TUBELESS READY

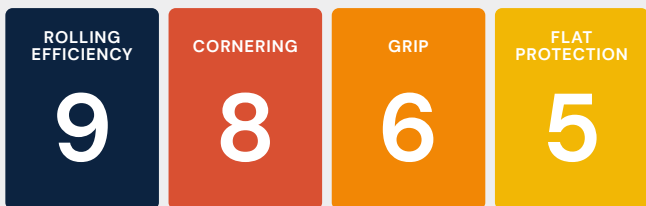

TUBELESS READY

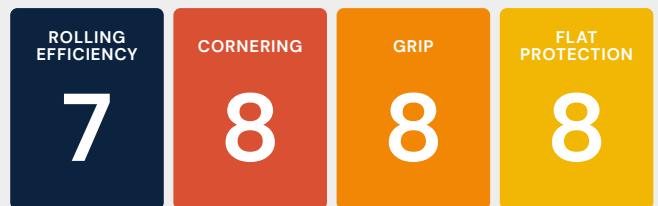

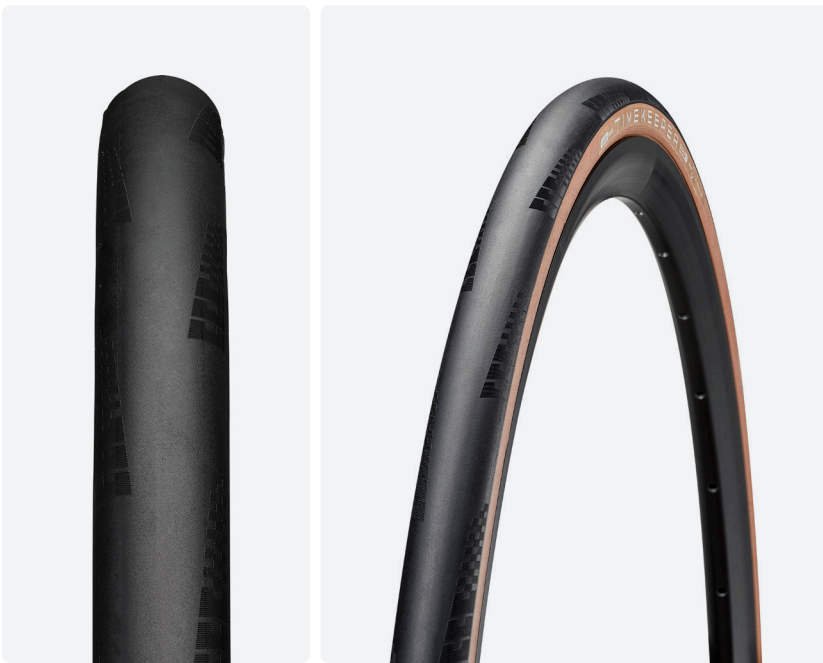

TIMEKEEPER

The Timekeeper is our premier road racing tire. Utilizing our signature Rubberforce S tread compound, now mixed with more silica, the Timekeeper is the fastest rolling tire in the American Classic road collection. With lightning-fast straight-line speed and confidence-inspiring cornering, the Timekeeper can help you set your next segment PR and climb the ranks of the weeknight crit. The 120 TPI construction and Stage 3 Armor and Stage 3S Armor flat protection make for a supple and smooth-riding tire that can fend off common puncture hazards. The Timekeeper is available in Tubeless Ready and tube type constructions with sidewall color choices of black or tan.



ROLLING EFFICIENCY	CORNERING	GRIP	FLAT PROTECTION
9	8	6	4 TUBE TYPE 5 TUBELESS READY



SPECIFICATIONS

Article	Size	Sidewall Color	Technology	Bead	Compound	Protection	TPI	Weight	MSRP
3R70025TL-BLK-A	700x25 / 25-622	Black	Tubeless Ready	Folding	Rubberforce S	Stage 3S Armor	120	305g	USD 45
3R70025TL-TAN-A	700x25 / 25-622	Tan	Tubeless Ready	Folding	Rubberforce S	Stage 3S Armor	120	305g	USD 45
3R70028TL-BLK-A	700x28 / 28-622	Black	Tubeless Ready	Folding	Rubberforce S	Stage 3S Armor	120	335g	USD 45
3R70028TL-TAN-A	700x28 / 28-622	Tan	Tubeless Ready	Folding	Rubberforce S	Stage 3S Armor	120	335g	USD 45
3R70030TL-BLK-A	700x30 / 30-623	Black	Tubeless Ready	Folding	Rubberforce S	Stage 3S Armor	120	375g	USD 45
3R70030TL-TAN-A	700x30 / 30-622	Tan	Tubeless Ready	Folding	Rubberforce S	Stage 3S Armor	120	375g	USD 45
3R70025TT-BLK-A	700x25 / 25-622	Black	Tube Type	Folding	Rubberforce S	Stage 3 Armor	120	210g	USD 40
3R70025TT-TAN-A	700x25 / 25-622	Tan	Tube Type	Folding	Rubberforce S	Stage 3 Armor	120	215g	USD 40
3R70028TT-BLK-A	700x28 / 28-622	Black	Tube Type	Folding	Rubberforce S	Stage 3 Armor	120	235g	USD 40
3R70028TT-TAN-A	700x28 / 28-622	Tan	Tube Type	Folding	Rubberforce S	Stage 3 Armor	120	240g	USD 40
3R70030TT-BLK-A	700x30 / 30-622	Black	Tube Type	Folding	Rubberforce S	Stage 3 Armor	120	260g	USD 40
3R70030TT-TAN-A	700x30 / 30-624	Tan	Tube Type	Folding	Rubberforce S	Stage 3 Armor	120	265g	USD 40

TECHNOLOGY

TUBELESS READY

Ultimate construction of speed, comfort and flat protection.

STAGE 3 ARMOR

Ultralight puncture protection and a supple ride.

STAGE 3S ARMOR

Ultralight puncture and casing protection

ROAD HAZARD REPLACEMENT

A one-time 50% off MSRP replacement if you puncture or tear a tire while riding.

RUBBERFORCE S

The fastest compound synthesized for maximum speed and grip for road racing.



TORCHBEARER

The Torchbearer offers versatile performance in a variety of road conditions. Our progressive tread design provides excellent grip and handling to support your town-line sprint while providing low rolling resistance for long days in the saddle. The Stage 4 Armor and Stage 4S Armor flat protection provides all-weather-ready puncture and tear protection from bead to bead, and the 120 TPI construction delivers a responsive ride no matter the pavement condition. The Torchbearer is available in Tubeless Ready and tube type constructions with black sidewalls.



ROLLING EFFICIENCY	CORNERING	GRIP	FLAT PROTECTION
7	8	8	7 TUBE TYPE 8 TUBELESS READY



SPECIFICATIONS

Article	Size	Sidewall Color	Technology	Bead	Compound	Protection	TPI	Weight	MSRP
5R70025TL-BLK-A	700x25 / 25-622	Black	Tubeless Ready	Folding	Rubberforce S	Stage 4S Armor	120	365	USD 45
5R70028TL-BLK-A	700x28 / 28-622	Black	Tubeless Ready	Folding	Rubberforce S	Stage 4S Armor	120	380	USD 45
5R70032TL-BLK-A	700x32 / 32-622	Black	Tubeless Ready	Folding	Rubberforce S	Stage 4S Armor	120	395	USD 45
5R70025TT-BLK-A	700x25 / 25-622	Black	Tube Type	Folding	Rubberforce S	Stage 4 Armor	120	270	USD 40
5R70028TT-BLK-A	700x28 / 28-622	Black	Tube Type	Folding	Rubberforce S	Stage 4 Armor	120	275	USD 40
5R70032TT-BLK-A	700x32 / 32-622	Black	Tube Type	Folding	Rubberforce S	Stage 4 Armor	120	300	USD 40

TECHNOLOGY

TUBELESS READY

Ultimate construction of speed, comfort and flat protection.

STAGE 4 ARMOR

Bead to bead cut and puncture protection.

STAGE 4S ARMOR

2 layers of bead to bead cut and puncture protection.

ROAD HAZARD REPLACEMENT

A one-time 50% off MSRP replacement if you puncture or tear a tire while riding.

RUBBERFORCE S

The fastest compound synthesized for maximum speed and grip for road racing.



LAMPLIGHTER

The Lamplighter is our modern E-bike and city performance tire designed to get you anywhere with ease - thanks to its Rubberforce R compound that balances speed, traction, and reliability. The Stage 7 Armor construction makes it nearly impervious to flats while our progressive tread pattern provides traction across varied pavement and light trail surfaces. The continuous center section is road-bike-fast, with micro-siping to clear water and improve wet traction and cornering. The Lamplighter is available in tube type construction with black sidewalls.



E BIKE READY



SPECIFICATIONS

Article	Size	Sidewall Color	Technology	Bead	Compound	Protection	TPI	Weight	MSRP
7R70040TT-BLK-A	700x40 / 40-622	Black	Tube Type	Folding	Rubberforce R	Stage 7 Armor	60	580	USD 40
7R70050TT-BLK-A	700x50 / 50-622	Black	Tube Type	Folding	Rubberforce R	Stage 7 Armor	60	710	USD 40
7R65047TT-BLK-A	650bx47 / 47-584	Black	Tube Type	Folding	Rubberforce R	Stage 7 Armor	60	670	USD 40

TECHNOLOGY

TUBE TYPE

Advanced construction for dependable, universal performance.

STAGE 7 ARMOR

Double puncture protection and long lasting performance.

ROAD HAZARD REPLACEMENT

A one-time 50% off MSRP replacement if you puncture or tear a tire while riding.

RUBBERFORCE R

The modern compound balancing speed, traction, and reliability for city riding.



MODELS	USAGE	GRIP INTENSITY
--------	-------	----------------

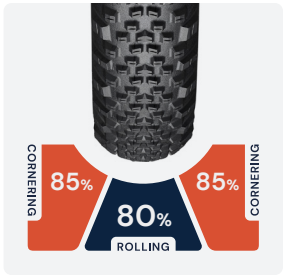
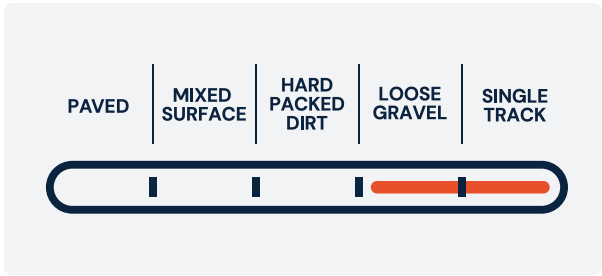
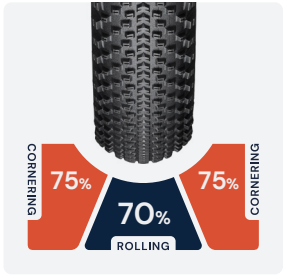
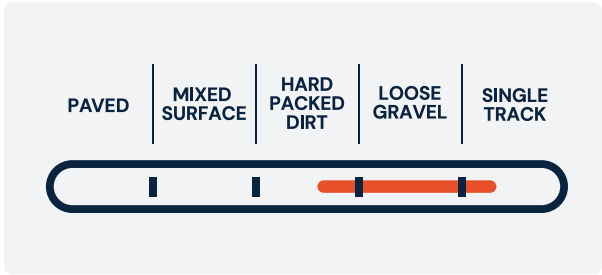
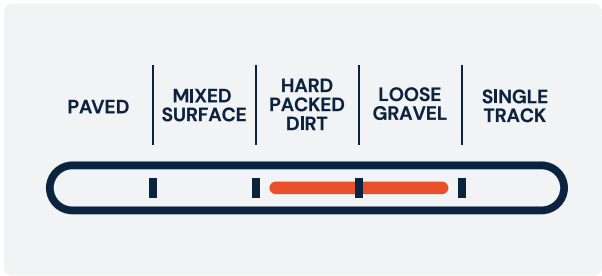
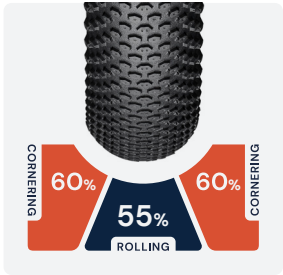
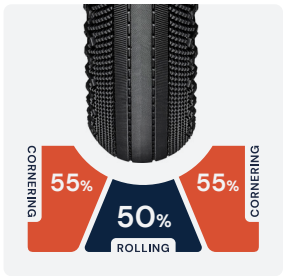



KIMBERLITE

For fast adventures on both pavement and gravel, look to the Kimberlite tire. This go-anywhere tire performs like a road tire on pavement and hooks up on hardpack dirt surfaces. The semi-slick tread starts with a smooth center for decreased rolling resistance on smoother surfaces, transitions thru progressively more aggressive zones for maximum lateral traction, and wraps up with robust edge knobs for dependable cornering. The Tubeless 120 TPI casing provides the ultimate construction for speed and comfort, and the Stage 5S Armor provides a tire that is lighter, faster, and more cut, tear, and abrasion resistant. The Kimberlite is available in Tubeless Ready construction with sidewall color choices of black, tan, and brown.



PAVED | MIXED SURFACE | HARD PACKED DIRT | LOOSE GRAVEL | SINGLE TRACK



SPECIFICATIONS

Article	Size	Sidewall Color	Technology	Bead	Compound	Protection	TPI	Weight	MSRP
OG70035TL-BLK-A	700x35 / 35-622	Black	Tubeless Ready	Folding	Rubberforce G	Stage 5S Armor	120	490g	USD 45
OG70035TL-TAN-A	700x35 / 35-622	Tan	Tubeless Ready	Folding	Rubberforce G	Stage 5S Armor	120	490g	USD 45
OG70035TL-BWN-A	700x35 / 35-622	Brown	Tubeless Ready	Folding	Rubberforce G	Stage 5S Armor	120	490g	USD 45
OG70040TL-BLK-A	700x40 / 40-622	Black	Tubeless Ready	Folding	Rubberforce G	Stage 5S Armor	120	520g	USD 45
OG70040TL-TAN-A	700x40 / 40-622	Tan	Tubeless Ready	Folding	Rubberforce G	Stage 5S Armor	120	525g	USD 45
OG70040TL-BWN-A	700x40 / 40-622	Brown	Tubeless Ready	Folding	Rubberforce G	Stage 5S Armor	120	525g	USD 45
OG70050TL-BLK-A	700x50 / 50-622	Black	Tubeless Ready	Folding	Rubberforce G	Stage 5S Armor	120	640g	USD 45
OG70050TL-TAN-A	700x50 / 50-622	Tan	Tubeless Ready	Folding	Rubberforce G	Stage 5S Armor	120	640g	USD 45
OG70050TL-BWN-A	700x50 / 50-622	Brown	Tubeless Ready	Folding	Rubberforce G	Stage 5S Armor	120	640g	USD 45
OG65047TL-BLK-A	650bx47 / 47-584	Black	Tubeless Ready	Folding	Rubberforce G	Stage 5S Armor	120	600g	USD 45
OG65047TL-TAN-A	650bx47 / 47-584	Tan	Tubeless Ready	Folding	Rubberforce G	Stage 5S Armor	120	605g	USD 45
OG65047TL-BWN-A	650bx47 / 47-584	Brown	Tubeless Ready	Folding	Rubberforce G	Stage 5S Armor	120	605g	USD 45

TECHNOLOGY

TUBELESS READY

Ultimate construction of speed, comfort and flat protection.

STAGE 5S ARMOR

Casing protection and secure hold for rough terrain.

ROAD HAZARD REPLACEMENT

A one-time 50% off MSRP replacement if you puncture or tear a tire while riding.

RUBBERFORCE G

The compound engineered for dependable grip and fully-built for adventure.

GRIP INTENSITY

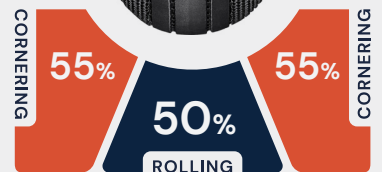



AGGREGATE

The Aggregate is the optimal all-around tire for paved, hardpack, and light gravel terrain. The evenly spaced knobs speed over smoother surfaces with minimal vibration while their hexagonal shape provides predictable handling over looser conditions. That is combined with our signature Rubberforce G tread compounds for impressive grip in the dirt and the new Stage 5S Armor construction offers both supreme ride quality and abrasion resistance. The Aggregate is available in Tubeless Ready construction with sidewall color choices of black, tan, and brown.



PAVED | MIXED SURFACE | HARD PACKED DIRT | LOOSE GRAVEL | SINGLE TRACK



SPECIFICATIONS

Article	Size	Sidewall Color	Technology	Bead	Compound	Protection	TPI	Weight	MSRP
2G70040TL-BLK-A	700x40 / 40-622	Black	Tubeless Ready	Folding	Rubberforce G	Stage 5S Armor	120	480g	USD 45
2G70040TL-TAN-A	700x40 / 40-622	Tan	Tubeless Ready	Folding	Rubberforce G	Stage 5S Armor	120	485g	USD 45
2G70040TL-BWN-A	700x40 / 40-622	Brown	Tubeless Ready	Folding	Rubberforce G	Stage 5S Armor	120	485g	USD 45
2G70050TL-BLK-A	700x50 / 50-622	Black	Tubeless Ready	Folding	Rubberforce G	Stage 5S Armor	120	605g	USD 45
2G70050TL-TAN-A	700x50 / 50-622	Tan	Tubeless Ready	Folding	Rubberforce G	Stage 5S Armor	120	610g	USD 45
2G70050TL-BWN-A	700x50 / 50-622	Brown	Tubeless Ready	Folding	Rubberforce G	Stage 5S Armor	120	610g	USD 45
2G65047TL-BLK-A	650bx47 / 47-584	Black	Tubeless Ready	Folding	Rubberforce G	Stage 5S Armor	120	560g	USD 45
2G65047TL-TAN-A	650bx47 / 47-584	Tan	Tubeless Ready	Folding	Rubberforce G	Stage 5S Armor	120	565g	USD 45
2G65047TL-BWN-A	650bx47 / 47-584	Brown	Tubeless Ready	Folding	Rubberforce G	Stage 5S Armor	120	565g	USD 45

TECHNOLOGY

TUBELESS READY

Ultimate construction of speed, comfort and flat protection.

STAGE 5S ARMOR

Casing protection and secure hold for rough terrain.

ROAD HAZARD REPLACEMENT

A one-time 50% off MSRP replacement if you puncture or tear a tire while riding.

RUBBERFORCE G

The compound engineered for dependable grip and fully-built for adventure.

GRIP INTENSITY





UDDEN

The Udden features tightly-spaced, low-profile center knobs with aggressive cornering tread for an efficient tire that works well across hardpack, dirt and gravel. The Udden is suited for long days of exploration and lining up on next corner where anything could be around the next corner. As the results of years of R&D we have created the specially-tuned Rubberforce G tread compound and Stage 5S Armor construction giving the Udden impressive grip in the dirt and improved ride quality and abrasion resistance. The Udden is available in Tubeless Ready construction with sidewall color choices of black, tan, and brown.



SPECIFICATIONS

Article	Size	Sidewall Color	Technology	Bead	Compound	Protection	TPI	Weight	MSRP
4G70040TL-BLK-A	700x40 / 40-622	Black	Tubeless Ready	Folding	Rubberforce G	Stage 5S Armor	120	520g	USD 45
4G70040TL-TAN-A	700x40 / 40-622	Tan	Tubeless Ready	Folding	Rubberforce G	Stage 5S Armor	120	525g	USD 45
4G70040TL-BWN-A	700x40 / 40-622	Brown	Tubeless Ready	Folding	Rubberforce G	Stage 5S Armor	120	525g	USD 45
4G70050TL-BLK-A	700x50 / 50-622	Black	Tubeless Ready	Folding	Rubberforce G	Stage 5S Armor	120	610g	USD 45
4G70050TL-TAN-A	700x50 / 50-622	Tan	Tubeless Ready	Folding	Rubberforce G	Stage 5S Armor	120	615g	USD 45
4G70050TL-BWN-A	700x50 / 50-622	Brown	Tubeless Ready	Folding	Rubberforce G	Stage 5S Armor	120	615g	USD 45
4G65047TL-BLK-A	650bx47 / 47-584	Black	Tubeless Ready	Folding	Rubberforce G	Stage 5S Armor	120	570g	USD 45
4G65047TL-TAN-A	650bx47 / 47-584	Tan	Tubeless Ready	Folding	Rubberforce G	Stage 5S Armor	120	575g	USD 45
4G65047TL-BWN-A	650bx47 / 47-584	Brown	Tubeless Ready	Folding	Rubberforce G	Stage 5S Armor	120	575g	USD 45

TECHNOLOGY

TUBELESS READY

Ultimate construction of speed, comfort and flat protection.

STAGE 5S ARMOR

Casing protection and secure hold for rough terrain.

ROAD HAZARD REPLACEMENT

A one-time 50% off MSRP replacement if you puncture or tear a tire while riding.

RUBBERFORCE G

The compound engineered for dependable grip and fully-built for adventure.

GRIP INTENSITY





WENTWORTH

The Wentworth features an innovative tread design that is both fast-rolling and mud-clearing for riding through the worst conditions without sacrificing pedaling efficiency on hardpack. The central chevrons provide straight-line speed, while the widely spaced side knobs allow you to carve through ruts and damp corners while powering through slippery transitions. Combined with our signature Rubberforce G tread compound and new Stage 5S Armor construction, this tire provides impressive grip in the dirt and improves both ride quality and abrasion resistance compared to its predecessor. The Wentworth is available in Tubeless Ready construction with sidewall color choices of black, tan, and brown.



PAVED | MIXED SURFACE | HARD PACKED DIRT | LOOSE GRAVEL | SINGLE TRACK



SPECIFICATIONS

Article	Size	Sidewall Color	Technology	Bead	Compound	Protection	TPI	Weight	MSRP
6G70040TL-BLK-A	700x40 / 40-622	Black	Tubeless Ready	Folding	Rubberforce G	Stage 5S Armor	120	505g	USD 45
6G70040TL-TAN-A	700x40 / 40-622	Tan	Tubeless Ready	Folding	Rubberforce G	Stage 5S Armor	120	510g	USD 45
6G70040TL-BWN-A	700x40 / 40-622	Brown	Tubeless Ready	Folding	Rubberforce G	Stage 5S Armor	120	510g	USD 45
6G70050TL-BLK-A	700x50 / 50-622	Black	Tubeless Ready	Folding	Rubberforce G	Stage 5S Armor	120	650g	USD 45
6G70050TL-TAN-A	700x50 / 50-622	Tan	Tubeless Ready	Folding	Rubberforce G	Stage 5S Armor	120	655g	USD 45
6G70050TL-BWN-A	700x50 / 50-622	Brown	Tubeless Ready	Folding	Rubberforce G	Stage 5S Armor	120	655g	USD 45
6G65047TL-BLK-A	650bx47 / 47-584	Black	Tubeless Ready	Folding	Rubberforce G	Stage 5S Armor	120	605g	USD 45
6G65047TL-TAN-A	650bx47 / 47-584	Tan	Tubeless Ready	Folding	Rubberforce G	Stage 5S Armor	120	610g	USD 45
6G65047TL-BWN-A	650bx47 / 47-584	Brown	Tubeless Ready	Folding	Rubberforce G	Stage 5S Armor	120	610g	USD 45

TECHNOLOGY

TUBELESS READY

Ultimate construction of speed, comfort and flat protection.

STAGE 5S ARMOR

Casing protection and secure hold for rough terrain.

ROAD HAZARD REPLACEMENT

A one-time 50% off MSRP replacement if you puncture or tear a tire while riding.

RUBBERFORCE G

The compound engineered for dependable grip and fully-built for adventure.

GRIP INTENSITY





KRUMBEIN

The Krumbein is American Classic's most aggressive gravel tire ideal for gravel roads, loose trails, and fast singletrack. The all-weather design includes tall side lugs for cornering grip on loose and rocky conditions, chamfered center knobs minimize rolling resistance, and there is plenty of space between knobs to prevent mud build-up. Combined with our signature Rubberforce G tread compounds and Stage 5S Armor construction, this tire provides impressive grip in the dirt and improves both ride quality and abrasion resistance compared to its predecessor. The Krumbein is available in Tubeless Ready construction with sidewall color choices of black, tan, and brown.



PAVED | MIXED SURFACE | HARD PACKED DIRT | LOOSE GRAVEL | SINGLE TRACK



SPECIFICATIONS

Article	Size	Sidewall Color	Technology	Bead	Compound	Protection	TPI	Weight	MSRP
8G70040TL-BLK-A	700x40 / 40-622	Black	Tubeless Ready	Folding	Rubberforce G	Stage 5S Armor	120	540g	USD 45
8G70040TL-TAN-A	700x40 / 40-622	Tan	Tubeless Ready	Folding	Rubberforce G	Stage 5S Armor	120	545g	USD 45
8G70040TL-BWN-A	700x40 / 40-622	Brown	Tubeless Ready	Folding	Rubberforce G	Stage 5S Armor	120	545g	USD 45
8G70050TL-BLK-A	700x50 / 50-622	Black	Tubeless Ready	Folding	Rubberforce G	Stage 5S Armor	120	670g	USD 45
8G70050TL-TAN-A	700x50 / 50-622	Tan	Tubeless Ready	Folding	Rubberforce G	Stage 5S Armor	120	675g	USD 45
8G70050TL-BWN-A	700x50 / 50-622	Brown	Tubeless Ready	Folding	Rubberforce G	Stage 5S Armor	120	675g	USD 45
8G65047TL-BLK-A	650bx47 / 47-584	Black	Tubeless Ready	Folding	Rubberforce G	Stage 5S Armor	120	625g	USD 45
8G65047TL-TAN-A	650bx47 / 47-584	Tan	Tubeless Ready	Folding	Rubberforce G	Stage 5S Armor	120	630g	USD 45
8G65047TL-BWN-A	650bx47 / 47-584	Brown	Tubeless Ready	Folding	Rubberforce G	Stage 5S Armor	120	630g	USD 45

TECHNOLOGY

TUBELESS READY

Ultimate construction of speed, comfort and flat protection.

STAGE 5S ARMOR

Casing protection and secure hold for rough terrain.

ROAD HAZARD REPLACEMENT

A one-time 50% off MSRP replacement if you puncture or tear a tire while riding.

RUBBERFORCE G

The compound engineered for dependable grip and fully-built for adventure.

GRIP INTENSITY





TECTONITE

The Tectonite front-specific tire relies on a directional tread that includes ramped center knobs, angled shoulder lugs, and alternating transition knobs to provide numerous angles of traction for consistent and reliable cornering no matter how hard you push into the turn. For optimal performance pair the Tectonite with a Basanite tire on the rear wheel.

The Tectonite is available in both Trail and Enduro versions with casing, construction, and tread compounds specific to the intended use. Trail models feature our Stage TR Armor construction for efficient climbing, predictable cornering, and long days on singletrack. Enduro models feature our Stage EN Armor construction for a tire that provides grip through blind corners, confidence over rock gardens, and the ability to cruise back up the trail. Both Stage TR Armor and Stage EN Armor constructions are Tubeless Ready.



SPECIFICATIONS

Article	Size	Position	Sidewall Color	Technology	Bead	Protection	TPI	Weight	MSRP
1M29250EN-BLK-A	29x2.5 / 64-622	Front	Black	Tubeless Ready	Folding	Stage EN Armor	120	1230g	USD 50
1M27250EN-BLK-A	27.5x2.5 / 64-584	Front	Black	Tubeless Ready	Folding	Stage EN Armor	120	1150g	USD 50
1M29250TR-BLK-A	29x2.5 / 64-622	Front	Black	Tubeless Ready	Folding	Stage TR Armor	60	1080g	USD 48
1M27250TR-BLK-A	27.5x2.5 / 64-584	Front	Black	Tubeless Ready	Folding	Stage TR Armor	60	1010g	USD 48

TECHNOLOGY

TUBELESS READY

Ultimate construction of speed, comfort and flat protection.

ROADHAZARD REPLACEMENT

A one-time 50% off MSRP replacement if you puncture or tear a tire while riding.

STAGE EN ARMOR

Enduro-Rated construction for higher speeds on aggressive terrain

STAGE TR ARMOR

Lightweight Trail-Rated construction with an aggressive tread for dry and rocky terrain.





BASANITE

Loose berms, choppy trails, and rugged rock gardens stand no chance against the Basanite. The Basanite is designed as a rear tire with ramped knobs for improved speed that alternate in shape and size for braking control. Alternating shoulder lugs and central knobs provide grip at any angle. The large knobs all include hatch marks, or cupped profiles, improving grip on harder-packed terrain.

The Basanite is available in both Trail and Enduro versions with casing, construction, and tread compounds specific to the intended use. Trail models feature our Stage TR Armor construction for efficient climbing, predictable cornering, and long days on singletrack. Enduro models feature our Stage EN Armor construction for a tire that provides grip through blind corners, confidence over rock gardens, and the ability to cruise back up the trail. Both Stage TR Armor and Stage EN Armor constructions are Tubeless Ready.



SPECIFICATIONS

Article	Size	Position	Sidewall Color	Technology	Bead	Protection	TPI	Weight	MSRP
3M29240EN-BLK-A	29x2.4 / 61-622	Rear	Black	Tubeless Ready	Folding	Stage EN Armor	120	1200g	USD 50
3M27240EN-BLK-A	27.5x2.4 / 61-584	Rear	Black	Tubeless Ready	Folding	Stage EN Armor	120	1120g	USD 50
3M29240TR-BLK-A	29x2.4 / 61-622	Rear	Black	Tubeless Ready	Folding	Stage TR Armor	60	1050g	USD 48
3M27240TR-BLK-A	27.5x2.4 / 61-584	Rear	Black	Tubeless Ready	Folding	Stage TR Armor	60	990g	USD 48

TECHNOLOGY

TUBELESS READY

Ultimate construction of speed, comfort and flat protection.

ROAD HAZARD REPLACEMENT

A one-time 50% off MSRP replacement if you puncture or tear a tire while riding.

STAGE EN ARMOR

Enduro-Rated construction for higher speeds on aggressive terrain.

STAGE TR ARMOR

Lightweight Trail-Rated construction with an aggressive tread for dry and rocky terrain.





VULCANITE

The Vulcanite is a go-anywhere tire featuring tall knobs for traction in loose terrain with hatch marks and siping for additional traction in hard-packed conditions, and ramped central knobs for straight-line speed. And its semi-open tread block layout reduces debris build-up and increases bite on rocky terrain and roots.

The Vulcanite is available in both Trail and Enduro versions with casing, construction, and tread compounds specific to the intended use. Trail models feature our Stage TR Armor construction for efficient climbing, predictable cornering, and long days on singletrack. Enduro models feature our Stage EN Armor construction for a tire that provides grip through blind corners, confidence over rock gardens, and the ability to cruise back up the trail. Both Stage TR Armor and Stage EN Armor constructions are Tubeless Ready.



SPECIFICATIONS

Article	Size	Position	Sidewall Color	Technology	Bead	Protection	TPI	Weight	MSRP
5M29250EN-BLK-A	29x2.5 / 64-622	Front or Rear	Black	Tubeless Ready	Folding	Stage EN Armor	120	1230g	USD 50
5M27250EN-BLK-A	27.5x2.5 / 64-584	Front or Rear	Black	Tubeless Ready	Folding	Stage EN Armor	120	1150g	USD 50
5M29250TR-BLK-A	29x2.5 / 64-622	Front or Rear	Black	Tubeless Ready	Folding	Stage TR Armor	60	1080g	USD 48
5M27250TR-BLK-A	27.5x2.5 / 64-584	Front or Rear	Black	Tubeless Ready	Folding	Stage TR Armor	60	1010g	USD 48

TECHNOLOGY

TUBELESS READY

Ultimate construction of speed, comfort and flat protection.

ROAD HAZARD REPLACEMENT

A one-time 50% off MSRP replacement if you puncture or tear a tire while riding.

STAGE EN ARMOR

Enduro-Rated construction for higher speeds on aggressive terrain.

STAGE TR ARMOR

Lightweight Trail-Rated construction with an aggressive tread for dry and rocky terrain.





MAUKA

Mauka is Hawaiian for “toward the mountain” and that’s where this tire excels. This all-condition tire climbs like a cross-country tire and descends like a trail tire. We’ve engineered a downcountry tire that rips up long climbs and provides grip and confidence on descents by combining a fast-rolling center tread with sturdy side lugs, and our lightweight Stage TR-L construction. This is topped off with our signature Rubberforce G tread compound for impressive grip in off-road conditions. The Mauka is available in a Tubeless Ready construction with black sidewalls.



SPECIFICATIONS

Article	Size	Sidewall Color	Technology	Bead	Compound	Protection	TPI	Weight	MSRP
3D29240DC-BLK-A	29x2.4 / 61-622	Black	Tubeless Ready	Folding	Rubberforce G	Stage TR-L Armor	60	830g	USD 45

TECHNOLOGY

TUBELESS READY

Ultimate construction of speed, comfort and flat protection.

ROADHAZARD REPLACEMENT

A one-time 50% off MSRP replacement if you puncture or tear a tire while riding.

RUBBERFORCE G

The compound engineered for dependable grip and fully-built for adventure.

STAGE TR-L ARMOR

Stage TR-L is a lighter weight version of our Trail construction for aggressive cross-country use.





AMERICAN CLASSIC

AMCLASSIC.COM

v10, July 6 2022