



E8



TORO E8

Performance Curves

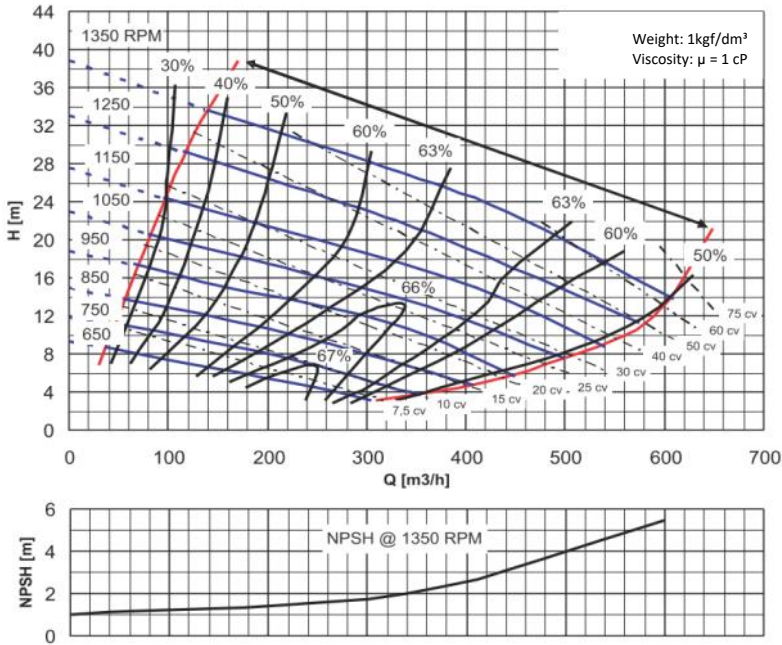

Specification

Maximum flow rate	605m ³ /h
Maximum height pressure	34m
Maximum speed	1350 rpm
Weight	574 kg
GD ²	2.8 (kg m ²)
Maximum diameter of solids	3"
Suction flange diameter	8" BSP
Discharge flange diameter	8" BSP
Rotor diameter	14 3/4"
Diameter of drain connections	2" BSP

Priming Height

650 rpm - 2.7m	1050 rpm - 6m
750 rpm - 3.6m	1150 rpm - 6.4m
850 rpm - 4.5m	1250 rpm - 6.7 m
950 rpm - 4.5m	1350 rpm - 7 m

Cutaway View

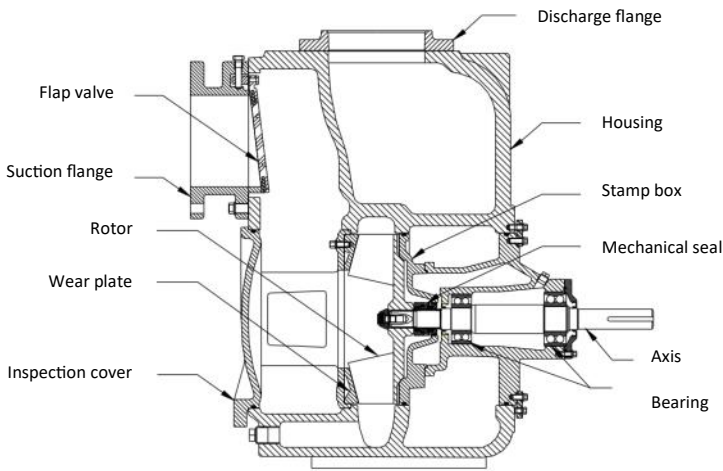

About TORO

Toro E self-priming pumps are the result of listening to our customers. Used on numerous projects around the world, they meet the demand for a self-priming pump with the same level of service and support as other Intrax products. Toro E is the ideal robust solution for a wide range of industries, highlighting conventional and lithium mining, chemical and petrochemical, among others. Available in a series of state-of-the-art coatings, they provide a finish resistant to abrasion and corrosion, guaranteeing the correct operation with dirty fluids or with suspended particles.

Dimension

