



HL40 Lamella Tank

40m² Settling Area Lamella Tank

The HL40 is designed to effectively recover suspended solid particles from water in continuous pumping applications.

The HL40 is a simple but effective way of ensuring that environmental pollution concerns of high suspended solids in water, from activity such as groundwork dewatering and silt laden wash water are safely met. This ensures compliance with authorities such as the Environment Agency and Water board's site water standards requirements.

These tanks are typically used with 4" pumps, though this can vary depending on the appropriate flow rate required. Where there are greater treatment volume requirements, multiple units can be easily connected in parallel to increase settlement capacity.

How it Works

Silt laden contaminated water is fed into the unit in the back chamber, where it flows around into the base of the lamella plate section of the tank. The water stream flows upward between the inclined Lamella plates. With the reduced flow, the solids fall to the plate surface, where they slide by gravity, down the plate, to the sludge collection chamber at the bottom. The sludge is then periodically drained down using the valve at the bottom of the hopper.

The HL40 effective settlement area is 40m², giving it a typical treatment flowrate of 20m³/h. The HL40 can be used in combination with coagulants and flocculants to remove superfine particles, heavy metals, and more.

Features

- Discharge ports for sludge and water
- Removable Lamella plates for easy cleaning
- Tapered sludge tank for fast effective sludge removal
- Provision for additional monitoring control to report on final water quality.
- Flocculation area
- Optional fixed ladder access and walkways for inspection and maintenance.

Benefits

- Safe solution for removing solids from water and minimising environmental damage to water courses
- Ensure compliance with Authority requirements
- Good practice for HSE requirements onsite
- Provides water suitable for safe discharge to foul or surface and inert sludge
- Easy and fast to deploy; minimal set up required
- Suitable for all suspended solids settlement
- Unlimited process time without complete washout
- Flocculant cages built into inlet for basic water treatment

Specification

Value	HL40	Unit
Mass (Empty)	3100	kg
Mass (Full)	9300	kg
Length	2.5	m
Width	2.4	m
Height	2.8	m
Settling Flowrate Limit	40	m ³ /h
Total Volume	6.2	m ³
Sludge Volume	1.1	m ³
Effective Settlement Area	40.04	m ²
Max Ground Slope Rise Widthways	30	mm
Max Ground Slope Rise Lengthways	80	mm
Max Ground Slope Widthways	0.8	deg
Max Ground Slope Lengthways	1.7	deg
Inlet Flange	DN100 PN10	-
Discharge Outlet Flange	DN150 PN16	-
Oil Skimmer Outlet	2" BSPT F Socket	-
Sludge Outlet Flange	DN100 PN10	-

EnviroHub is an Atlantic Pumps brand and is part of the Intrax Global Group. Atlantic Pumps Ltd is a Limited Company registered in England number 09400148. Registered Office: Atlantic Pumps, Unit 21 Prospect House, Colliery Close, Staveley, Derbyshire, United Kingdom, S43 3QE.

Layout Drawings

Dimension	HL40	Unit
A	2500	mm
B	2400	mm
C	2726	mm
D	2624	mm
E	2060	mm
F	2362	mm
H	1179	mm
I	800	mm
J	184	mm
K	766	mm

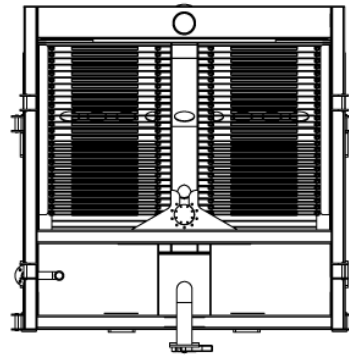

TOP

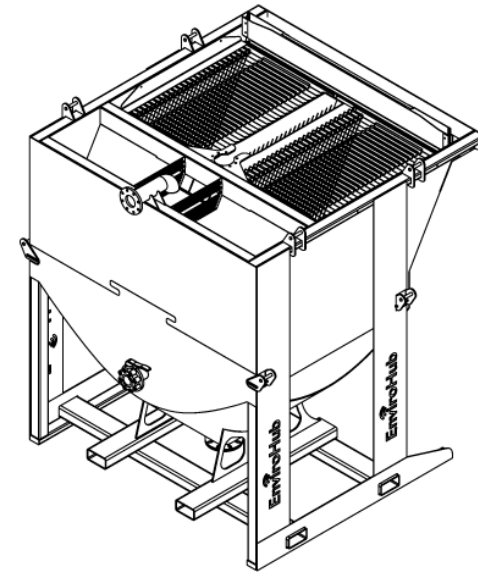

ISOMETRIC

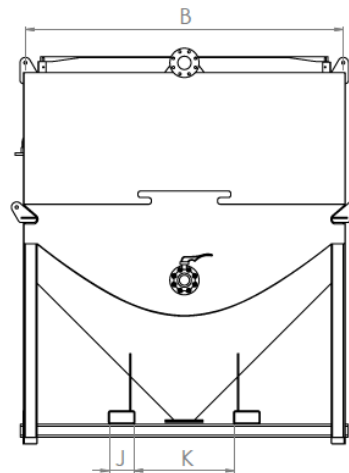

FRONT

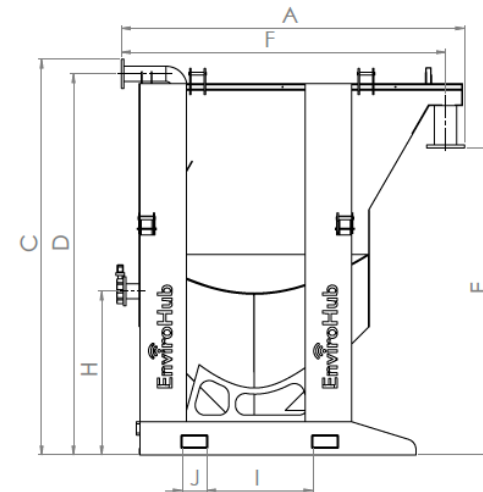

RIGHT