



HL10 Lamella Tank

10m2 Settling Area Lamella Tank

The HL10 is designed to effectively recover suspended solid particles from water in continuous pumping applications.

The HL10 is a simple but effective way of ensuring that environmental pollution concerns of high suspended solids in water, from activity such as groundwork dewatering and silt laden wash water are safely met. This ensures compliance with authorities such as the Environment Agency and Water board's site water standards requirements.

These tanks are typically used with 2" pumps, though this can vary depending on the appropriate flow rate required. Where there are greater treatment volume requirements, multiple units can be easily connected in parallel to increase settlement capacity.

How it Works

Silt laden contaminated water is fed into the unit in the back chamber, where it flows around into the base of the lamella plate section of the tank.

The water stream flows upward between the inclined Lamella plates. With the reduced flow, the solids fall to the plate surface, where they slide by gravity, down the plate, to the sludge collection chamber at the bottom. The sludge is then periodically drained down using the valve at the bottom of the hopper.

The HL10 effective settlement area is 10m², giving it a typical treatment flowrate of 5m³/H. The HL10 can be used in combination with coagulants and flocculants to remove superfine particles, heavy metals, and more.

Features

- Discharge ports for sludge and water
- Removable Lamella plates for easy cleaning
- Tapered sludge tank for fast effective sludge removal
- Provision for additional monitoring control to report on final water quality
- Flocculation area

Benefits

- Safe solution for removing solids from water and minimising environmental damage to watercourses
- Ensure compliance with Authority requirements
- Good practice for HSE requirements onsite
- Provides water suitable for safe discharge to foul or surface and inert sludge
- Easy and fast to deploy; minimal set up required
- Suitable for all suspended solids settlement
- Unlimited process time without complete washout
- Flocculant cages built into inlet for basic water treatment
- Easy transportation using either built in ground level lifting points or fork pockets

Specification

Value	HL10	Unit
Mass (Empty)	1300	kg
Mass (Full)	3800	kg
Length	2	m
Width	1.4	m
Height	2	m
Settling Flow Rate Limit	10	m ³ /h
Total Volume	2.5	m ³
Sludge Volume	0.25	m ³
Effective Settlement Area	9.975	m ²
Max Ground Slope Rise Widthways	30	mm
Max Ground Slope Rise Lengthways	80	mm
Max Ground Slope Widthways	1.2	deg
Max Ground Slope Lengthways	2.4	deg
Inlet Flange	DN80 PN10	-
Outlet Flange	DN100 PN10	-
Oil Skimmer Outlet	2" BSPT F Socket	-

EnviroHub is an Atlantic Pumps brand and is part of the Intrax Global Group. Atlantic Pumps Ltd is a Limited Company registered in England number 09400148. Registered Office: Atlantic Pumps, Unit 21 Prospect House, Colliery Close, Staveley, Derbyshire, United Kingdom, S43 3QE.

Layout Drawings

Dimension	HL10	Unit
A	1970	mm
B	1400	mm
C	1978	mm
D	1880	mm
E	1395	mm
F	1837	mm
G	227	mm
H	-	mm
I	800	mm
J	184	mm
K	626	mm
L	778	mm
M	991	mm

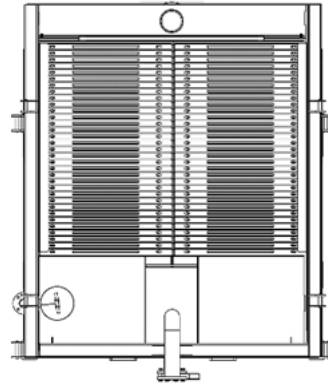

TOP

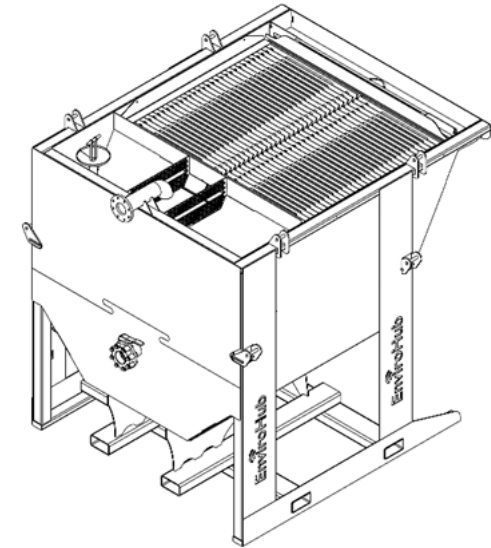

ISOMETRIC

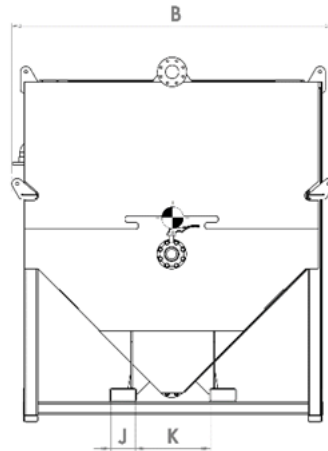

FRONT

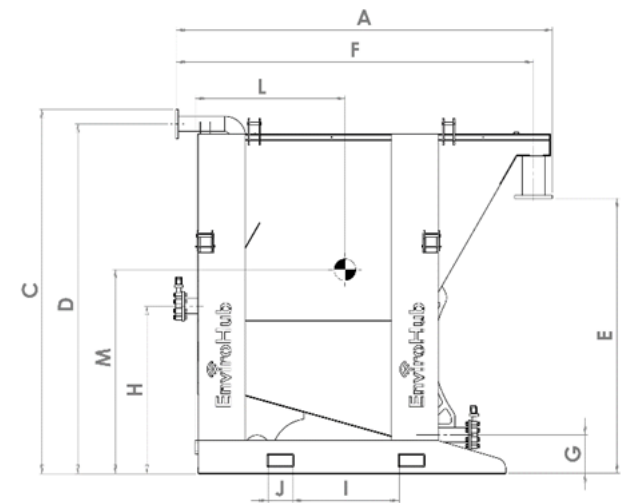

RIGHT