

AUDEX

AW PRO 2-150 TA

Designed with your industry in mind



Overview

- 2" Submersible dewatering pump
- Heavy duty cast iron body
- Lifting handle for carrying and suspending pump
- Proven and reliable design
- Rugged construction
- Built for abrasive applications
- Intelligent control system:
 - Built in water level sensor
 - Protection against reverse rotation, impeller jams and motor overload
 - High temperature cut-out
 - Automatic recovery and malfunction assessment

AUDEX
INDUSTRIAL DEWATERING

AUDEX AW PRO 2-150 TA

Specification

Capacity	Up to 30 m ³ /h
Head	Up to 20 metres
Power	1.5kW(2HP)
Power Supply	Three phase 400V±10%
Insulation Class	F
Protection Class	IP68
Cable Length	20m
Water Temperature	Up to 40°C
Max Water Depth	25m

Dimensions & Weights

d	50mm
A	235mm
A1	173mm
B	629mm
D	216mm
H	594mm
W1	135mm
N.W	43Kg
G.W	47Kg
Packing Dimensions	680 x 265 x 265

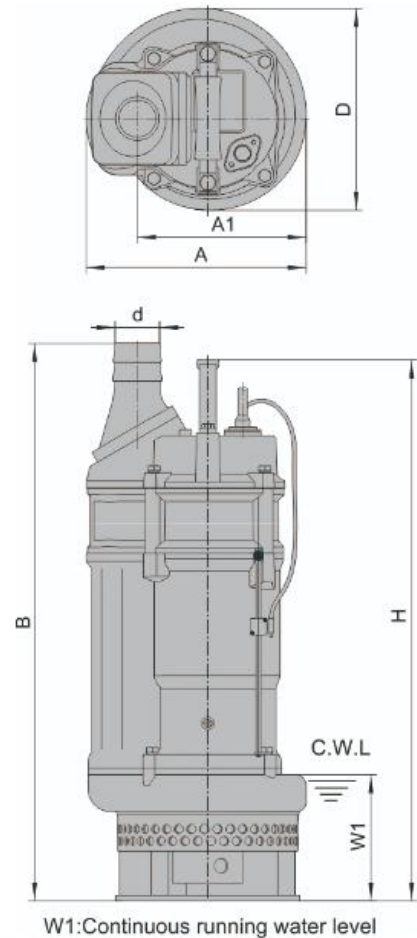

Performance

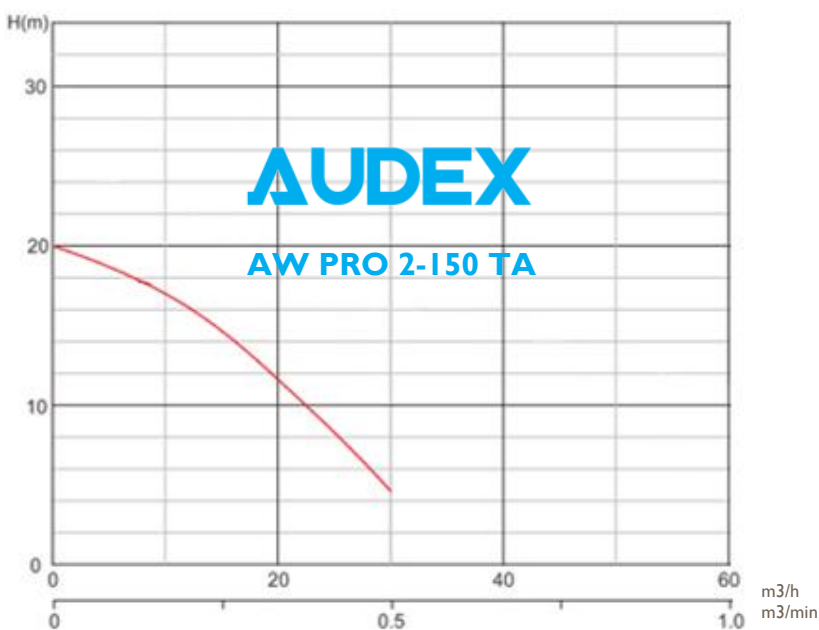

About Audex

Audex are respected manufacturers of industrial submersible and vac-prime self-priming dewatering pumps. Our pumps have been specifically developed for use in the toughest and most abrasive of applications and environments. Trusted by operators of quarries, mines and recycling facilities, Audex pumps represent quality and reliability giving you superior performance and reduced downtime. Pumps that suit your application better because they have been designed with your industry in mind.

Audex pumps are available in a range of sizes from 2" to 10" discharge, these robust pumps feature heavy-duty cast bodies, oversize shaft and bearings, hardened impellers and nitrile-lined diffusers and wear plates to maximize wear life when pumping abrasive liquids. Polyurethane lined diffuser and wear plates are available for extreme wear applications and the pumps are available in high head and stainless steel variants.

The submersible range of pumps are available with a seal fail detector system which monitors moisture levels and shuts down the pump in the event of seal wear or failure. This avoids costly rewinds and allows for a quick parts replacement without a costly full pump rebuild. Audex pumps also allow you to adjust the diffuser to compensate for wear.

Audex also manufacture a range of pontoons to mount our pumps on when installing in a lagoon, and discharge units to monitor site discharge. All this adds to up to increased pump life and less pump related down-time even in the most stringent environments.