

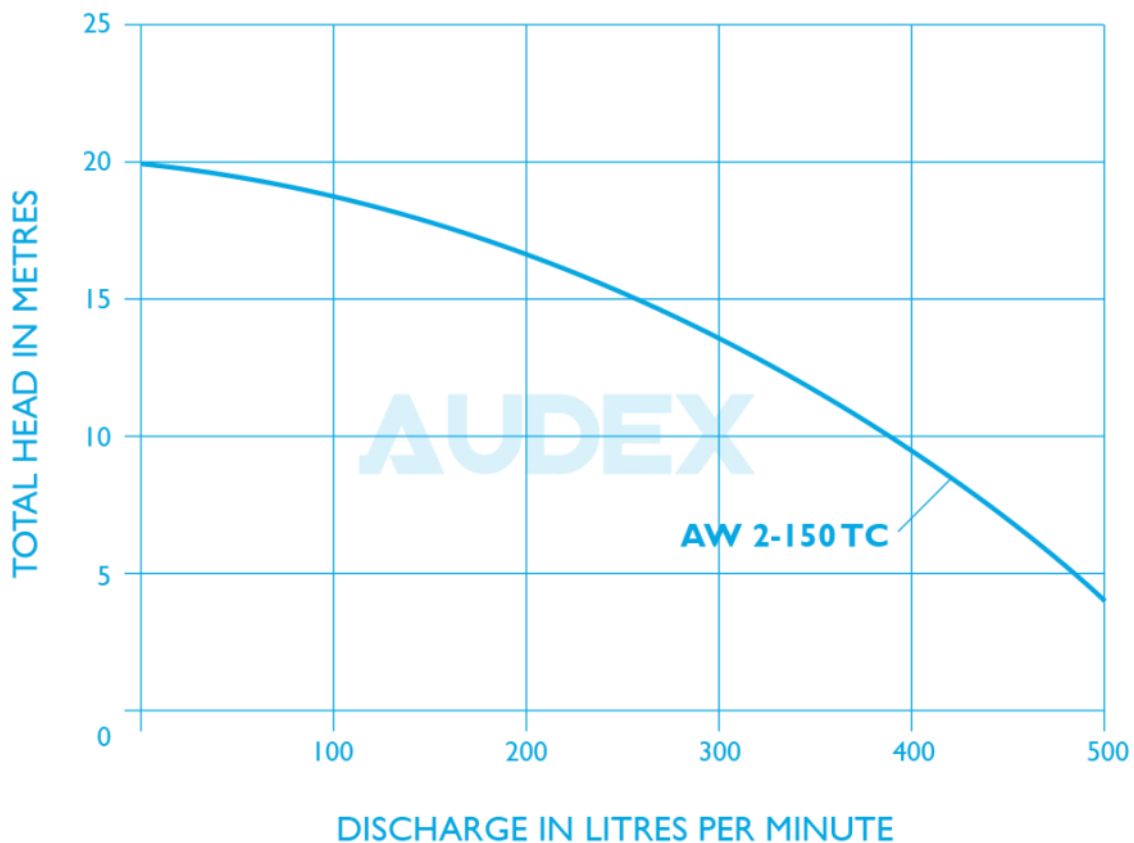

### AUDEX AW 2-150 TC 2" Submersible Dewatering Pump

- Cast iron made, heavy-duty slurry pump.
- An agitator is provided to assist smooth suction of the pumping fluid.
- The side-flow, top-discharge design keeps the motor cooling even if the pump is operated continuously with its motor exposed in air, and it makes the pump easier to be placed in a confined space.
- The pump is suitable for transferring or draining bentonite slurry used for slurry drilling, draining mixed water in civil engineering works or foundation works.
- Discharge: 50mm (2") Motor 1.5kW (2HP)

Audex are respected manufacturers of industrial submersible and vac-prime self-priming dewatering pumps. Our pumps have been specifically developed for use in the toughest and most abrasive of applications and environments. Trusted by operators of quarries, mines and recycling facilities, Audex pumps represent quality and reliability giving you superior performance and reduced downtime. Pumps that suit your application better because they have been designed with your industry in mind.



## Audex - Designed with your industry in mind

**NOTE** This information is for guidance / reference only.

For application specific drawings and curves, please contact your nearest authorised distributor at [audexpumps.com](http://audexpumps.com) 06.04.18

## AUDEX AW 2-150 TC

### Specification

Capacity: up to 30m<sup>3</sup>/hr  
 Head: up to 20m  
 Discharge: 50mm (2")  
 Power: 1.5kW (2HP)  
 Power supply: three phase 400V±10%, 50Hz  
 Insulation class: F  
 Protection class: IP68  
 Cable length: 8m  
 Water temperature: up to 40°C  
 Max. water depth: 25m

### Applications

Civil engineering  
 Mines, quarries, coal mine and slurries  
 Sewage treatment plants  
 General pumping purposes

### Special Features on Request

Other voltages  
 The length of cable is optional

### Dimensions

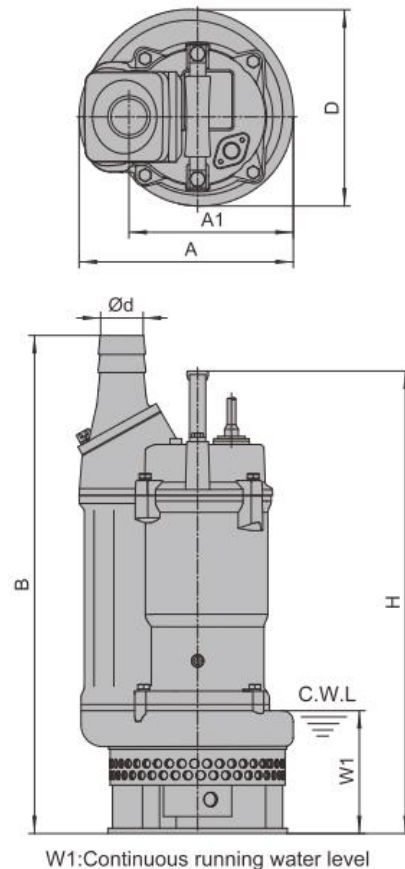

W1:Continuous running water level

D	50mm
A	235mm
A1	173mm
B	557mm
D	216mm
H	522mm
W1	135mm
N.W	37Kg
G.W	41Kg

Packing dimension  
 610 x 265 x 265mm

## Audex - Designed with your industry in mind

**NOTE** This information is for guidance / reference only.

For application specific drawings and curves, please contact your nearest authorised distributor at [audexpumps.com](http://audexpumps.com) 06.04.18