

COBRA SYSTEM R-SERIES

Instructions and Safety Manual



Read and follow all safety warnings and instructions in this manual.

Retain instructions and safety manual for future reference.

COBRA SYSTEM R-SERIES CROSSBOW INSTRUCTION MANUAL

Congratulations! You own an R-Series Crossbow! A compact, fast handling and powerful crossbow for your serious shooting enjoyment!

- The limb set comes pre-strung and is designed to be quickly attached or detached from the main body for transport and storage.
- With only a pen, nail, or bolt tip as a tool, the limb set and stock can be added or removed from the main body. With a little practice you will be able to put it together or take it apart in under ten seconds.
- Your R-Series can easily shoot good groups at 15m using its simple, open sight. The bolts that come with this crossbow have high energy and deep penetration on impact. **(Therefore you need to shoot at appropriate target materials and at safe distances. Don't underestimate the power of the bolts!)**
- It is necessary to practice a safe and correct form when operating the cocking arm and safety mechanism. **(Learn how to correctly cycle the R-Series Crossbow before trying to shoot proficiently.)** Otherwise, you can seriously harm yourself and cause your crossbow to have a short and sad service life.

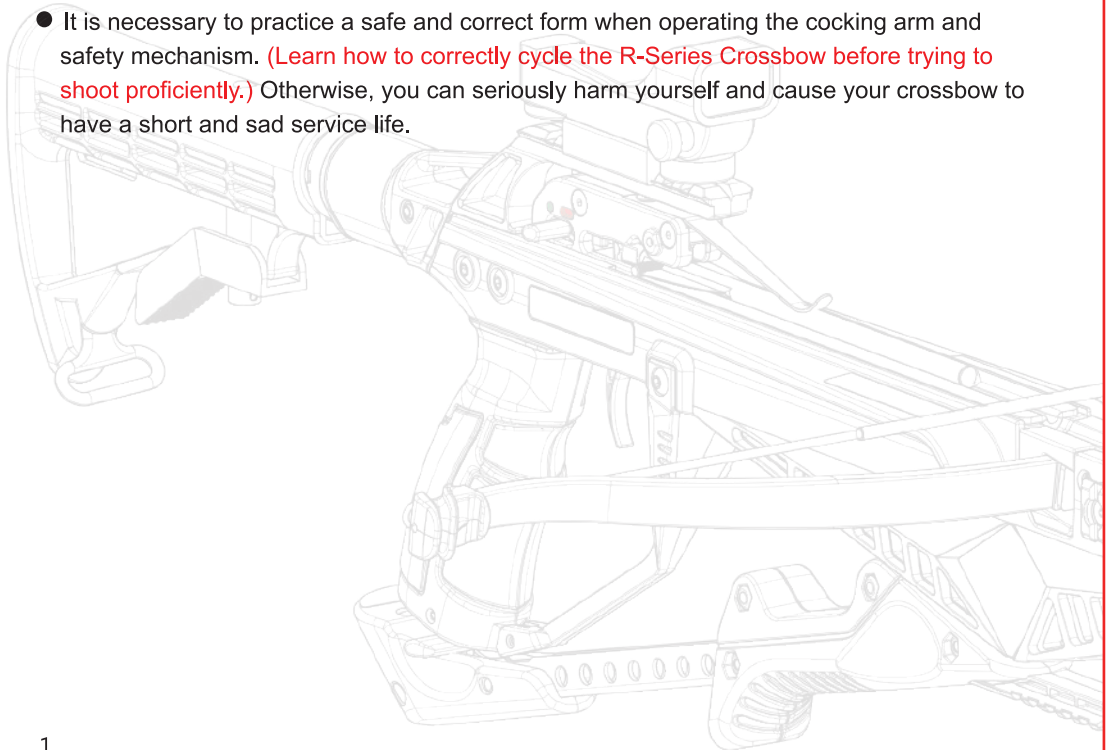

Crossbow Diagrams

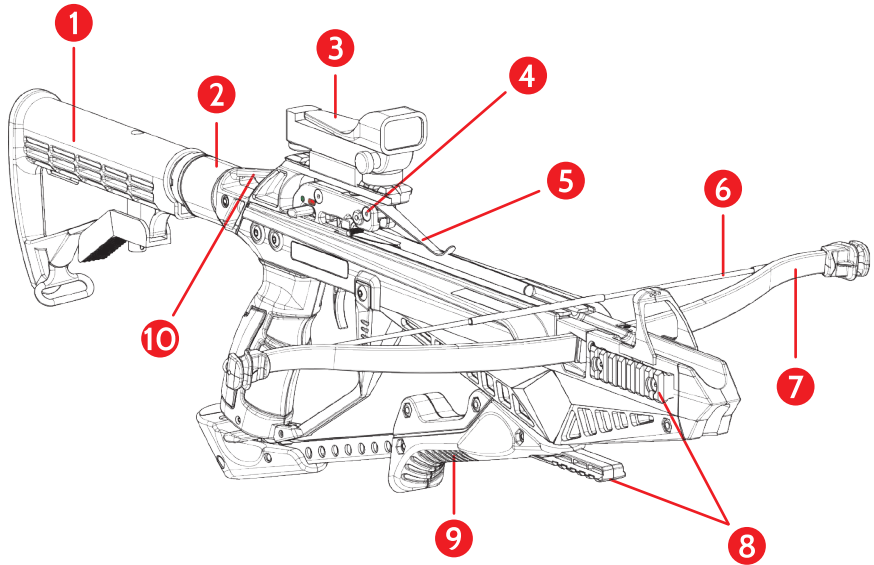

1. Stock (Extendable)
2. Buffer tube for tactical stock
3. Single position red dot sight
4. Trigger box with **fire/safe** latch
5. Crossbow bolt retention spring
6. String
7. Limb
8. Picatinny rail (Mounting optional accessories)
9. Foregrip (Adjustable position)
10. Sling mount

Package Includes :

► For Deluxe Package

- 6 x 7.5" Carbon Bolts
- 1 x String Wax
- 1 x Shoulder Sling
- 1 x AR Stock with Buffer Tube
- 1 x Single Position Red Dot Sight
- 1 x Simple Foregrip
- 1 x Safety Glasses

► For Standard Package

- 6 x 7.5" Carbon Bolts
- 1 x String Wax
- 1 x Safety Glasses

BEFORE YOU START SHOOTING! READ THIS!

DON'T LET ITS SIZE FOOL YOU! THE R-SERIES CROSSBOW IS A POWERFUL AND DANGEROUS DEVICE THAT WILL BITE YOU AND HARM OTHERS IF YOU UNDERESTIMATE IT OR DISREPECT IT. YOU HAVE BEEN WARNED!

Your R-Series Crossbow will reward you with a lot of shooting fun IF you read through the following instructions thoroughly.

EVEN MORE WARNINGS THAT YOU SHOULD READ:

- Obviously, this is not a toy and adult supervision is required. Misuse or careless use may cause serious injury, death or terrible lawsuits. Use common sense.
- It is extremely important to read and follow these instructions before attempting to use your crossbow. Serious injuries to yourself or others, damage to your crossbow, or poor performance from your crossbow could result from failure to thoroughly read and understand the instructions. Crossbows should only be used by those who are properly trained in safety or under the supervision of a qualified instructor.
- This is a high powered crossbow intended to be used by those who are 18 years of age and over.
- Purchasers and users should obey and follow all federal, state, and local laws and restrictions regarding the ownership and use of crossbows.
- **FEED YOUR CROSSBOW PROPERLY!** Use the bolts that are specifically designed for this crossbow. Usage of any other bolts may void the warranty service. **Bolts of improper stiffness, size, weight or length may cause damage to the crossbow and possibly causing personal injury.**

Parts of the crossbow:

Main body

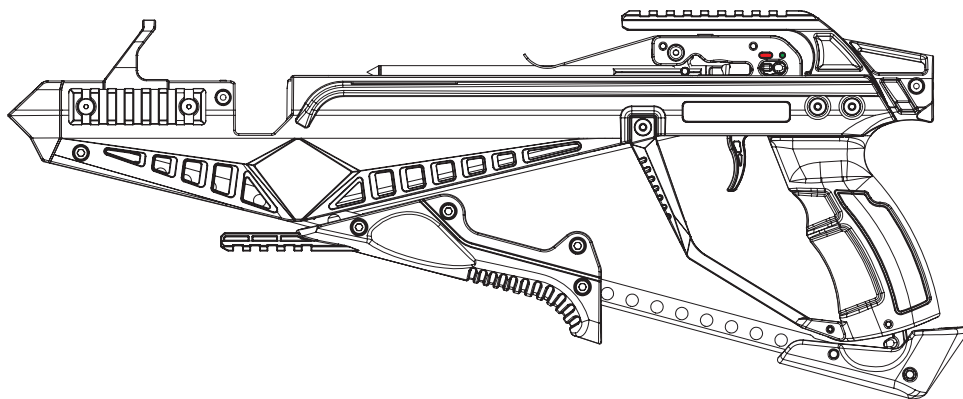

Pre-strung limb set

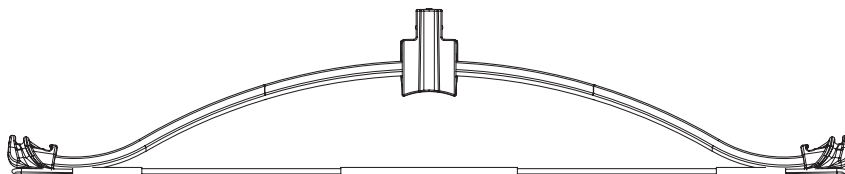

Assembly Guide

- A** Locate the quick release pin on the right side of the main body. Using a pen, nail, or bolt tip push the quick release pin in until it comes out the other side. Grab and pull the pin out until it stops.

IMPORTANT: The R-Series' Quick Locking Pins are not intended to be removed from the frame. Do not pull the pin using excessive force when assembling or disassembling the limb set or stock unit. If the Quick Locking Pin is stuck or comes out, send your R-Series Crossbow to a certified Ek Service Center for repair.

Limb quick release pin

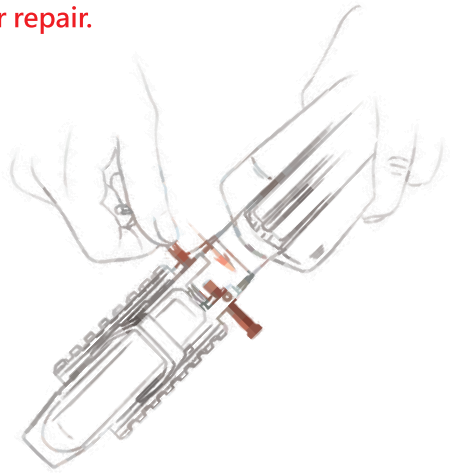
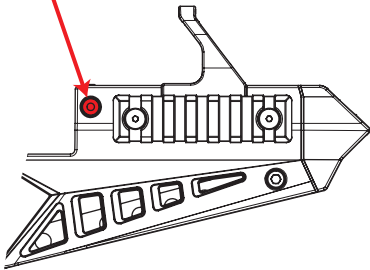

- B** Slide the limb set into the limb slot and press it gently and firmly into place.

STEP B-1

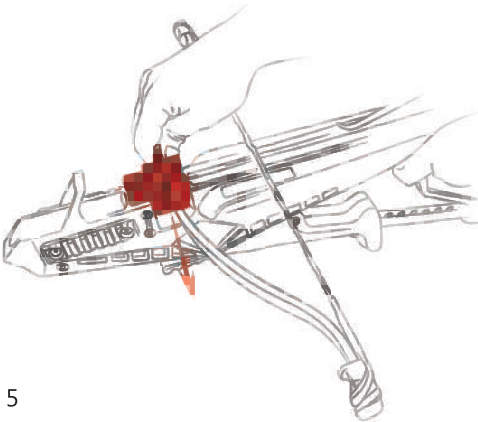

STEP B-2

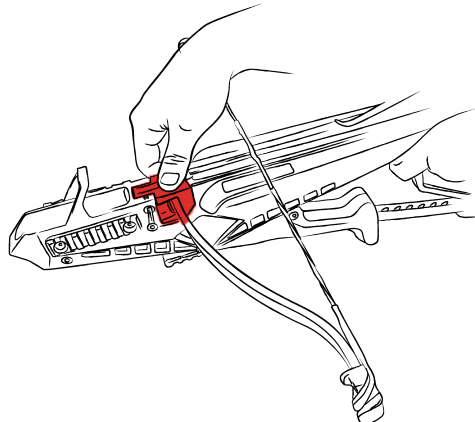

C

Push the quick release pin through the limb set until you hear a 'click' sound. Only when the quick release pin is completely locked back into position, is the limb set safely secured and ready to be cocked. (If the quick release pin does not easily go through the limb set, then the limb set is not properly seated in the limb slot.)

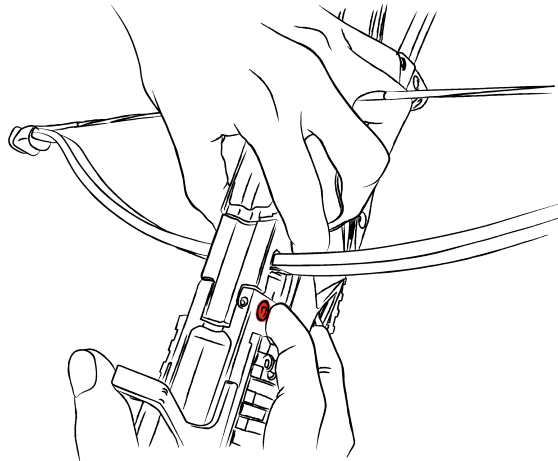
**D**

Assembly completed.

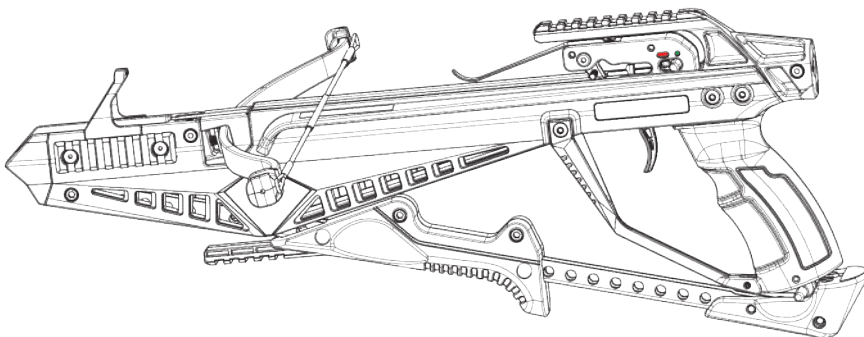

Operation Guide

Before using your R-Series Crossbow for first time, thoroughly wax the string. To maintain the string's life, keep it waxed.

- 1** Cocking the crossbow ,
Slide the safety forward into the Fire (red) position.

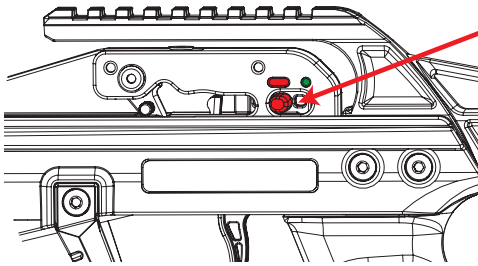

Safety in red "Fire" position.

- 2** Grab the Lever Lock with your thumb and pointer finger and pull the Lock backwards to release it from its housing in the base of the grip. Practice this movement a few times to get a feel for locking and unlocking the Lever.

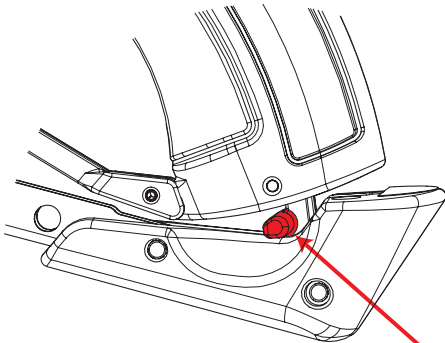

Lever Lock

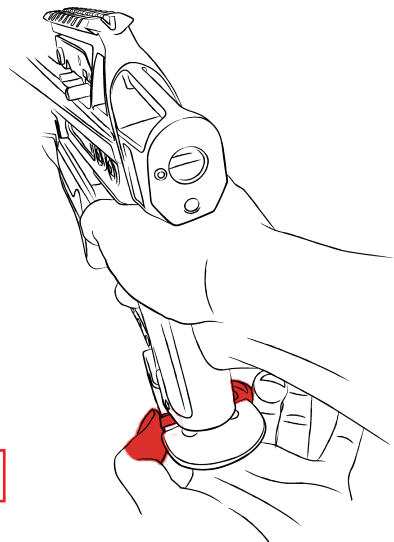

3 After the Lever Lock is released, swing the Lever forward until you can see the trigger assembly slide forward to hook the string behind the Trigger Latch. This action does not require much labor. Do not use too much power.

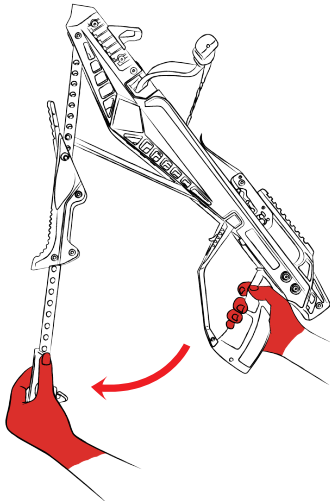

4 The string is correctly retained by the Trigger Latch. Note that the Safety has automatically slid backwards into the Safe position (green).

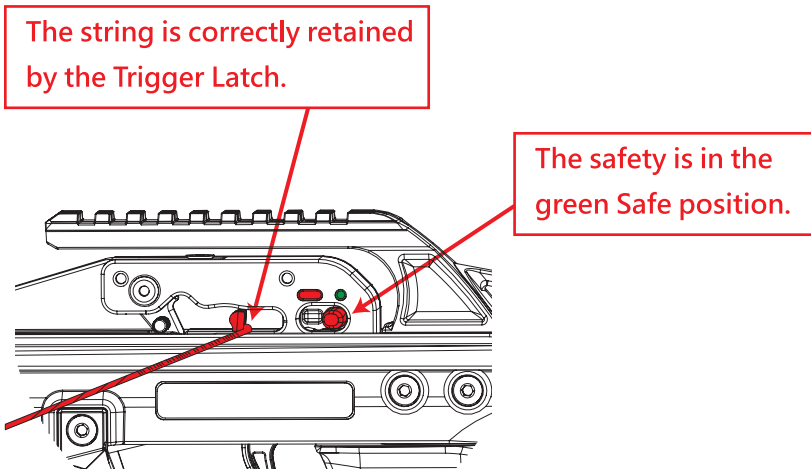

5

Firmly and evenly pull the Lever straight back to relock the Lever and complete the cocking of the crossbow. The Lever Lock should solidly engage the pistol grip with an audible click. (If the Lever Lock will not relock do not attempt to cock or fire the crossbow.)

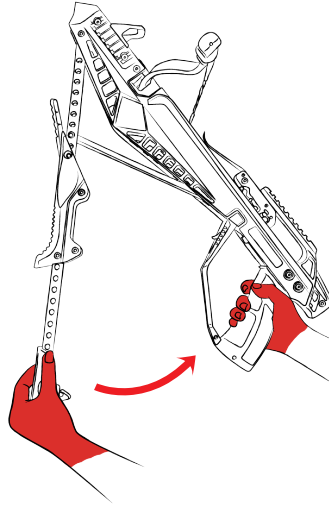
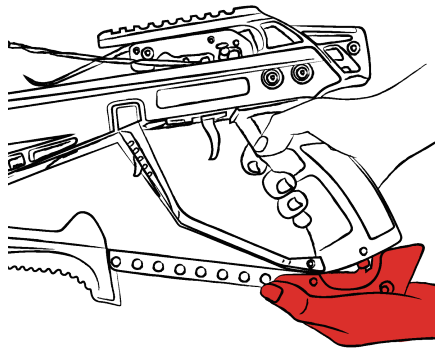
STEP 5-1**STEP 5-2****NOTE:**

When cocking the crossbow you will meet resistance as the string draws the limbs back into the firing position. Learn to use the appropriate amount of power to cock the crossbow. (The service life of the Lever mechanism will be extended by always using smooth movements when cycling the crossbow.)

Loading the bolt and firing

- A** Place the bolt evenly into the flight groove with the half-moon shapednock parallel to the string. Slide the bolt back under the retention spring, fully against the trigger latch hook.

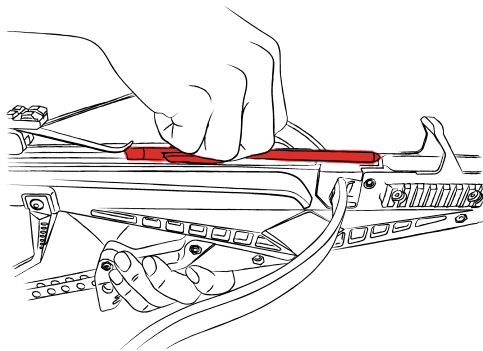

- ▶ The bolt is not pushed all the way back against the hook of the trigger latch, so the anti-dry fire mechanism is activated. This prevents the crossbow from being fired.

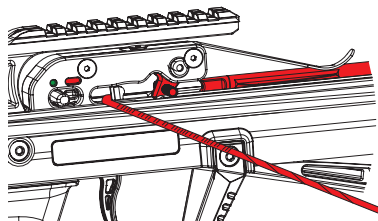

- ▶ The bolt is pushed all the way back against the hook of the trigger latch and the anti-dry fire mechanism is lifted, allowing the crossbow to be fired.

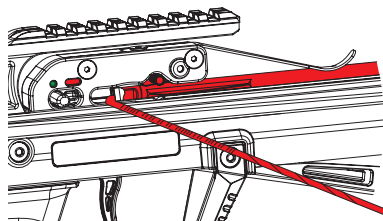

- B** Now it is time to Shoot! Slide the Safety forward into the Fire Position (Red). Aim and squeeze the trigger. Repeat!

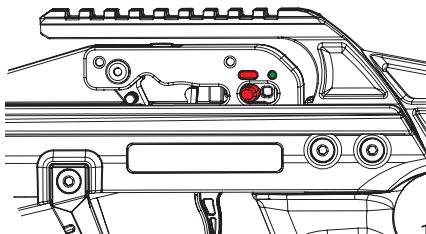

To disassemble R-Series Crossbow

Push out the limb set's quick release pin with a pen, nail, or bolt tip until it comes out on the other side. Grab and pull the pin out until it stops. You then can remove the limb set from the limb slot

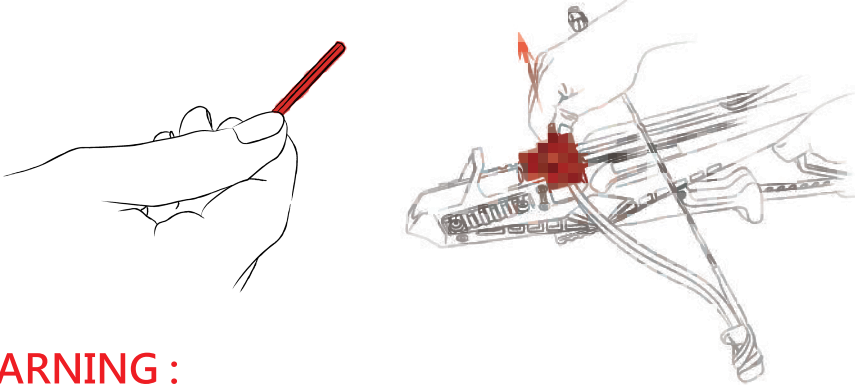

WARNING :

To avoid any injuries to yourself or others, or damage to your crossbow, the following safety instructions should be followed at all times. Understand the following images of common incorrect crossbow operations.

Incorrect hand (fingers) position during cocking :

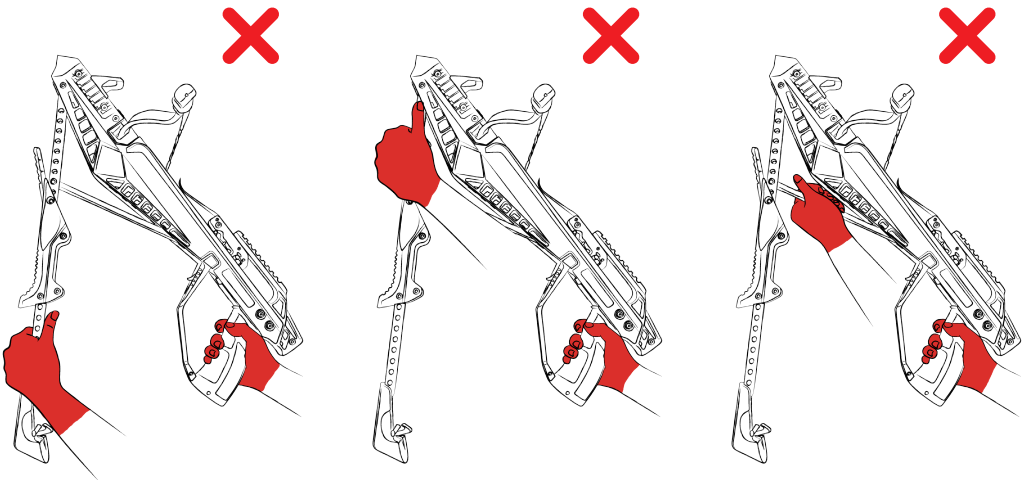

INCORRECT

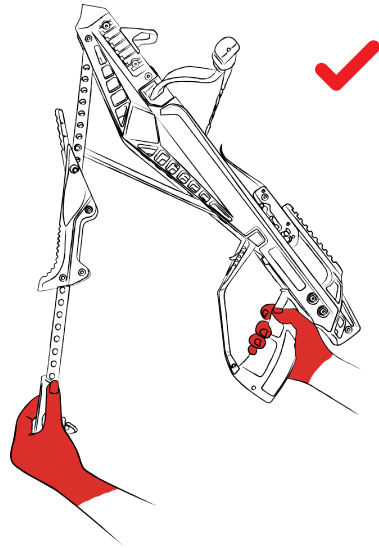
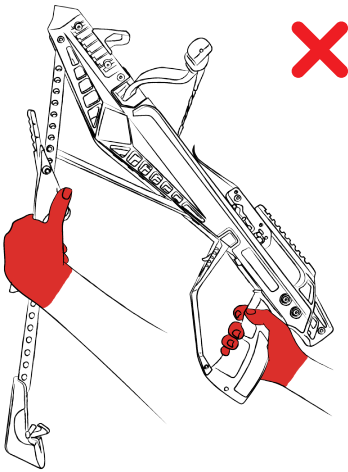

INCORRECT

CORRECT

Incorrect hand (fingers) position during Shooting :

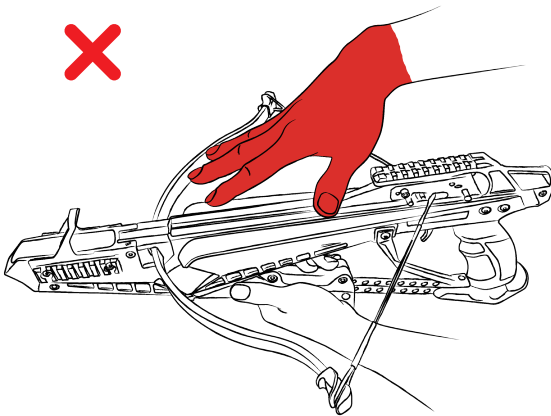

INCORRECT

Never allow your foregrip hand's fingers or thumb to move above the flight deck or into the bowstring's release path. Keep your hand and fingers in a safe position every time you cock, operate and shoot the crossbow. Placing your hands, fingers, thumbs or other body parts in the path of the bowstring will cause serious injury.

Troubleshooting

If you have cocked crossbow too quickly or incompletely, then it is not cycled correctly. The string is cocked but in the wrong place in between the trigger latch and the anti-dry fire mechanism. In this situation the crossbow can't be fired.

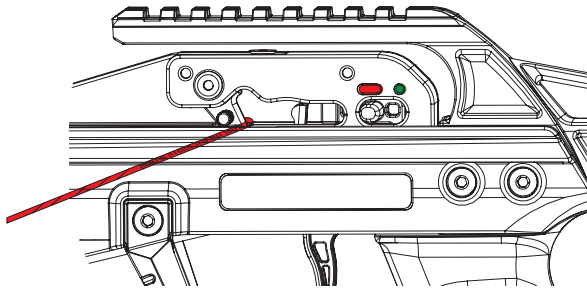

To resolve this situation carefully follow this procedure.

IMPORTANT! Remember the cocked Lever is under pressure from the Limbs. If it is unlocked without proper restraint it could quickly swing open causing you injury. Proceed carefully!

- 1** While keeping a very firm grip on the end of Lever, carefully unhook the Lever lock and let the lever swing forward in a controlled manner. Essentially, you are uncocking the crossbow. (**NOTE: The strength necessary to uncock the lever is more than required to cock it.**)

STEP 1-1

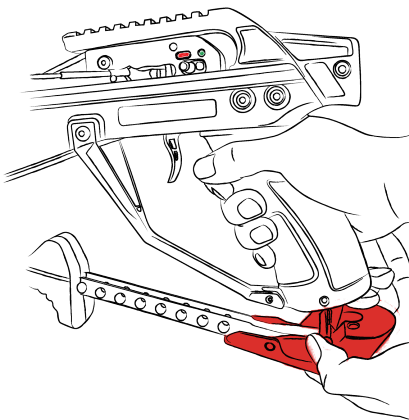

STEP 1-2

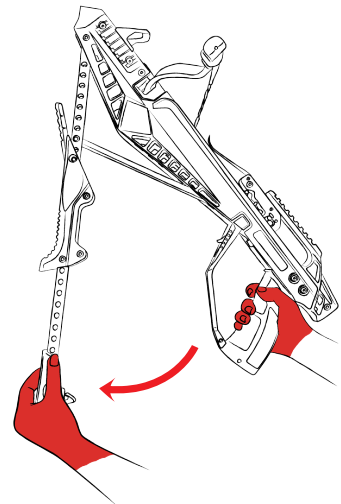

- 2** As the trigger assembly is cycled forward and the limbs are no longer under stress, you can lift the Anti-Dry Fire latch upward and free the string.

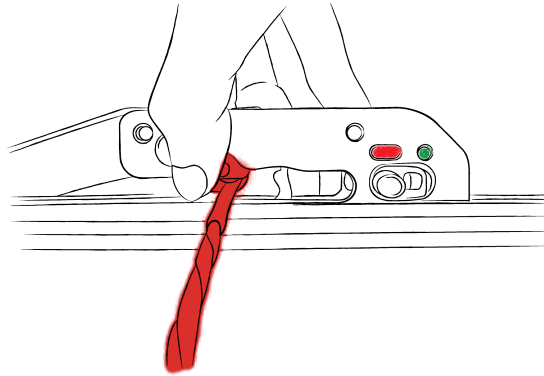

- 3** Pull the Lever back and gently cycle the trigger mechanism backwards to its original position.

STEP 3-1

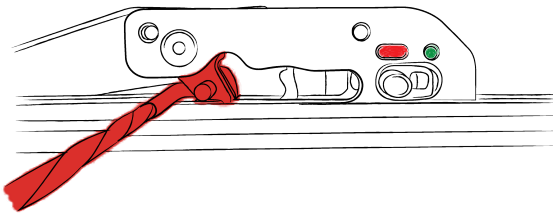

STEP 3-2

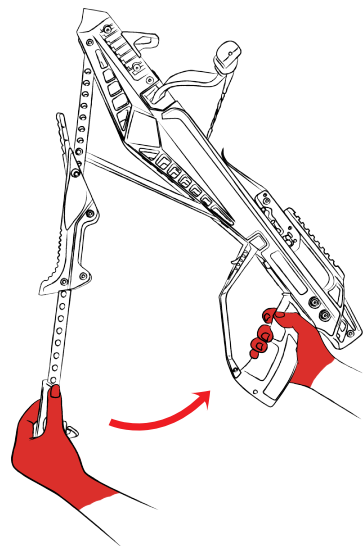

Safety Instructions

- Always make sure the bolts, screws and pins are securely tightened and in place before using.
- Never allow your fingers or thumb to move above the flight deck and keep them out of the path of the string while holding the fore-grip.
- Never **dry-fire** the crossbow. Shooting without a crossbow bolt is damaging to the crossbow. **Dry firing will void the warranty** and can result in damage to the limbs and string and possibly causing personal injury.
- Always inspect the crossbow equipment for worn, loose, damaged or missing parts. Replace any if missing, fraying or damaged parts are observed or suspected.
- Always point your crossbow in a safe direction and keep the crossbow out of the reach of children.
- Do not remove or deactivate your crossbow's safety features or accessories, potentially rendering the crossbow dangerous to you or others.
- Always keep all body parts clear of the bowstring's path during use.
- Always make sure the crossbow bolt is fully seated in the furthest back position to reduce possibility of dry fire.
- Replace strings if visible signs of fraying or broken strands are evident.
- Do not transport or store your crossbow while it is cocked or loaded.
- Do not attempt to use your crossbow under the influence of alcohol, prescription or non-prescription drugs.
- Always use suitable crossbow bolts. Crossbow Bolts of improper stiffness or weight may damage the limb set voiding the warranty and possibly causing personal injury.
- When practice shooting, wear eye protection and be sure your range is located in a spacious area free of buildings and your target is designed for crossbow use.

Maintenance And Care

1. Apply lubewax to the string and cables liberally. Do not over lubricate the center section of the crossbow string as this may cause a buildup of lubricant in the trigger mechanism. Keep the flight track and the string serving waxed to reduce friction. Always check and replace frayed or worn strings and cables.
2. Periodically put a few drops of high quality machine oil in the trigger mechanism.
3. Always store your crossbow in a cool, dry place. Do not expose your crossbow to excessive heat such as leaving it in an automobile trunk on a hot day or storing it next to a furnace vent.
4. Before each shooting session, examine all bolts (screws), pins and fasteners. Tighten all bolts (screws) as needed.
5. Be sure to have your crossbow examined annually by a qualified crossbow dealer.
6. Do not leave your crossbow cocked for extended periods of time or overnight.

Warranty Information

Subject to the terms, conditions and limitations outlined below, we guarantee 1 year warranty service to the original purchaser for our crossbows against defects in materials and workmanship that adversely affect the crossbow's operation. However, crossbow strings, cosmetic appearance and component parts and those which are subject to a variety of conditions in normal use and considered to be consumable parts will be excluded.

This limited warranty will be void if the following occur :

- Damage is caused by dry-firing or by using underweight arrows/bolts
- The instructions in the owner's manual are not followed
- The crossbow or any of its parts or accessories are altered from their original state
- The crossbow has not been maintained properly
- Failure or damage was caused by improper calibration or by abnormal use.

Please carefully package and return the product, transportation charges pre-paid to your dealers or distributors. All accessory items must be removed from the crossbow prior to shipping. If after examining a returned product, the dealer determines that the product is not subject to this limited warranty, product repairs can be provided at then-current repair rates informed by the dealer.

Warranty Registration must be mailed within 10 days of purchase to validate the warranty.

Dealer's contact information :

Model Number/Name

Date of Purchase

Purchaser's Name

Address

City

State

Zip Code

Email

Phone Number

