



HITCH MOUNT CARGO CARRIER KIT

RXHMCC
User Guide

CONTENTS

INTRODUCTION	3
SAFETY PRECAUTIONS	4
PARTS LIST	5
ASSEMBLY INSTRUCTIONS	7
ALSO AVAILABLE FOR PURCHASE	10
TECHNICAL SPECIFICATIONS	10
WARRANTY INFORMATION	11



HITCH MOUNT CARGO CARRIER KIT

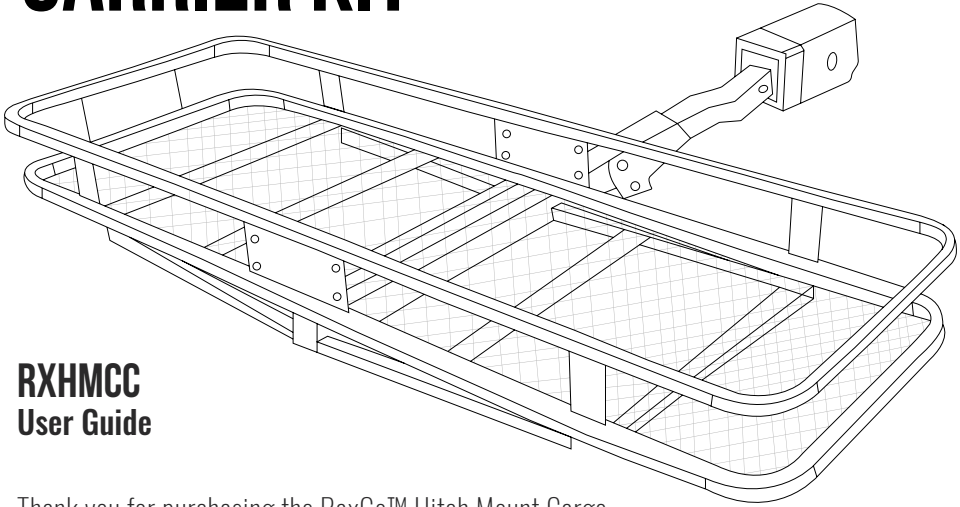

RXHMCC **User Guide**

Thank you for purchasing the RaxGo™ Hitch Mount Cargo Carrier Kit. This User Guide is intended to provide you with guidelines to ensure that operation of this product is safe and does not pose risk to the user. Any use that does not conform to the guidelines described in this User Guide may void the limited warranty.

Please read all directions before using the product and retain this guide for reference. This product is intended for personal use only. It is not intended for commercial use. This product is covered by a limited one-year warranty. Coverage is subject to limits and exclusions. See warranty for details.

SAFETY PRECAUTIONS



WARNING: CHOKING HAZARD – Small parts. This product contains small parts and is not suitable for children under 3 years old.

- Remove all packaging before using this device. Please keep all packaging materials out of reach of children and pets.
- Properly dispose of all packing materials immediately after unpacking product, as the bags used for packaging could present a suffocation or choking hazard.
- Read all instructions carefully before attempting to operate this device. Improper usage could result in injury or a reduction in efficacy.
- Make sure the hitch installed on your vehicle is rated to support up to 550 lbs. (249.5 kg.)
- When traveling with the carrier secured to a vehicle, do not exceed a speed of 80 mi/hr. (130 km/hr)
- Always check that the cargo is secure before beginning a trip.
- Make sure all the bolts and nuts are in good condition and do not appear rusted or worn out. Using worn parts can result in the rack not supporting the cargo properly.
- Be sure to research and follow all national and local regulations regarding carrying cargo on a vehicle.
- Do not exceed the rack's maximum capacity of 500 lbs. (226.8 kg.)
- Before beginning a trip, we recommend taking a test drive in a safe area to ensure the cargo is completely secure.
- Do not let children play on or around the rack as this can cause accidents, injuries, or damage the rack.

PARTS LIST

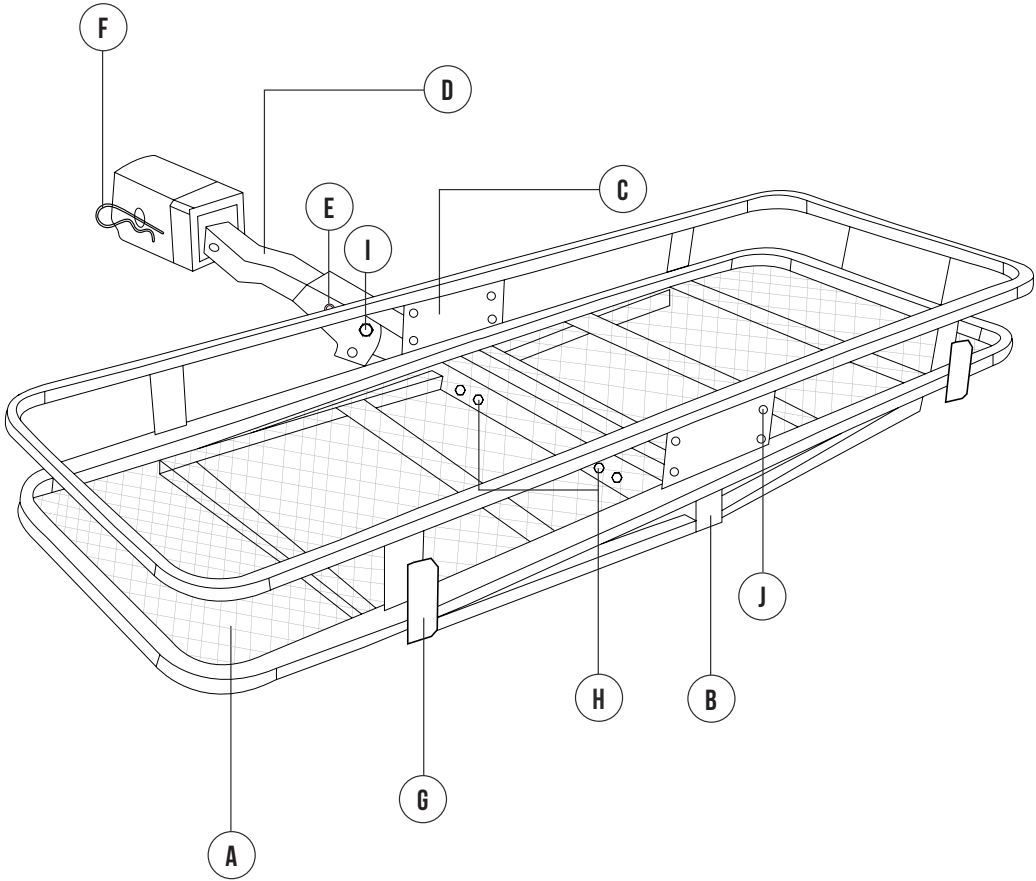

PARTS LIST

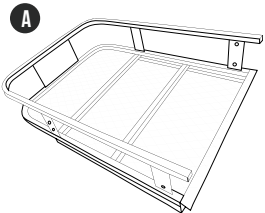
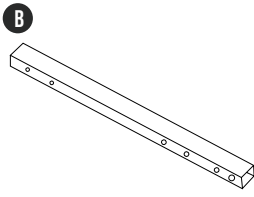
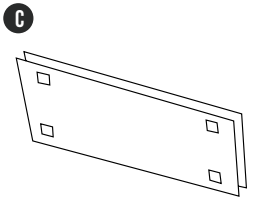
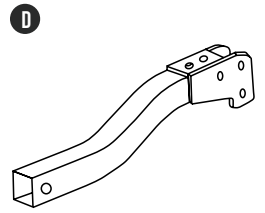
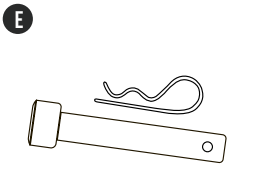
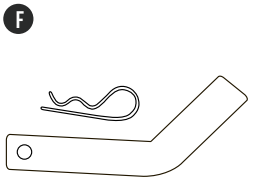
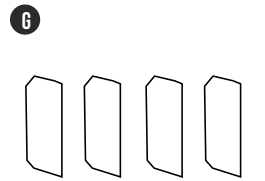
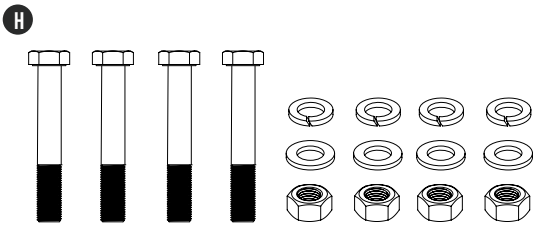
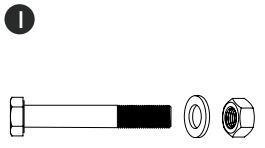
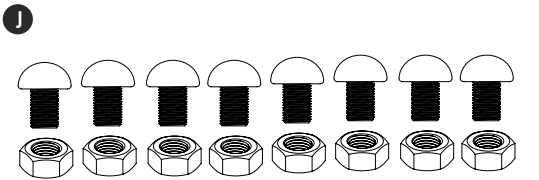
		
<p>Half Platform 2 PCS</p>	<p>Arm 1 PCS</p>	<p>Connection Plate 2 PCS</p>
		
<p>Hitch Tube 1 PCS</p>	<p>12mm Pin & Clip Set 1 PCS</p>	<p>16mm Pin & Clip Set 1 PCS</p>
		
<p>Waterproof Reflective Stickers 4 PCS</p>	<p>M10x70 Bolt Set 16 PCS</p>	
		
<p>M12x 75 Set 3 PCS</p>	<p>M8x16 Carriage Bolt Set 16 PCS</p>	

ASSEMBLY INSTRUCTIONS

1. Attach the **(B)** Arm to **(A)** Halves of Platform with **(H)** M10 x 70 Bolt Set.

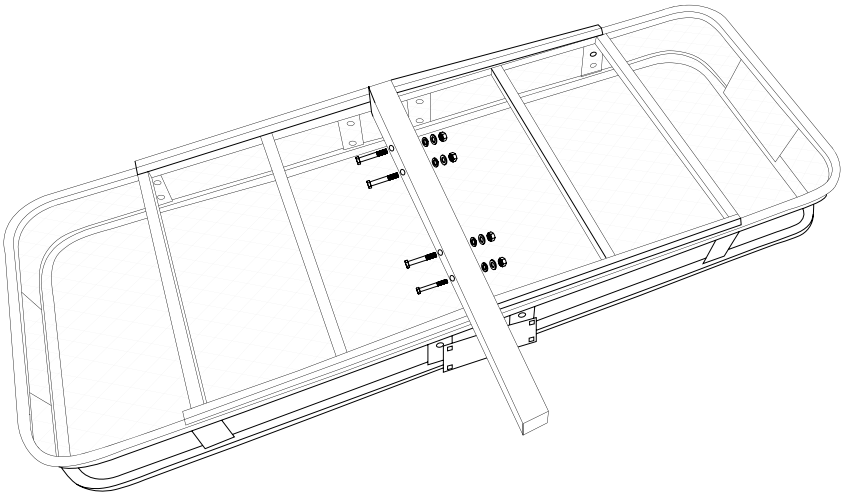

2. Assemble the Platform by attaching the **(C)** Connection Plates with **(J)** M8 x 16 Carriage Bolt Sets.

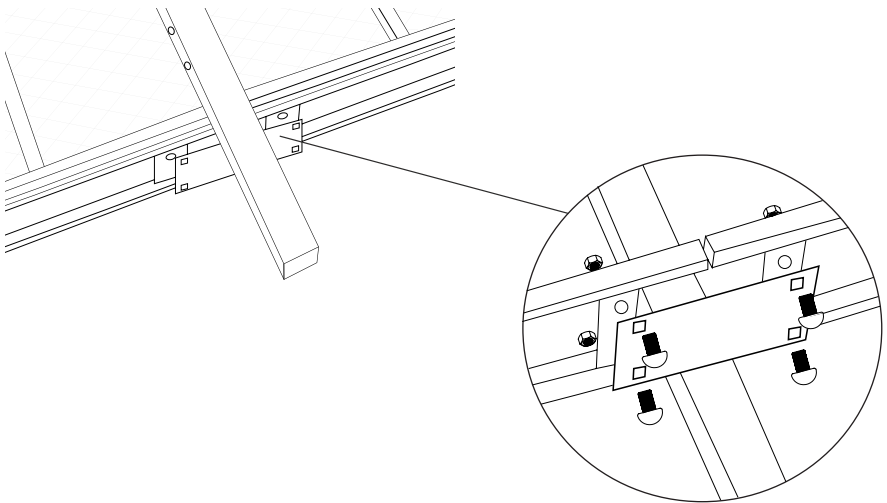

3. Connect the **(D)** Hitch Tube to the Platform by using **(I)** M12 x 75 Bolt Set and **(E)** 12mm Pin and Clip Set.

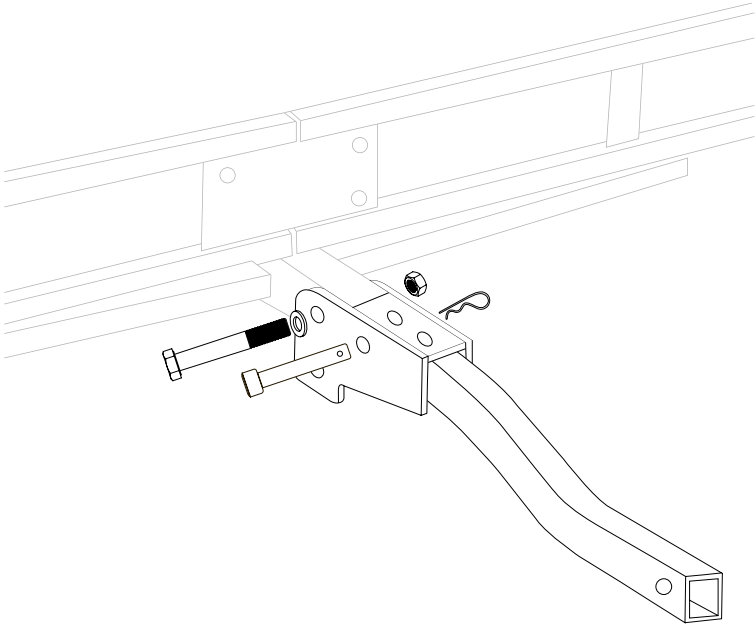

4. Mount the Assembled Carrier to your vehicle's hitch receiver by using **(F)** 16mm Pin and Clip Set.

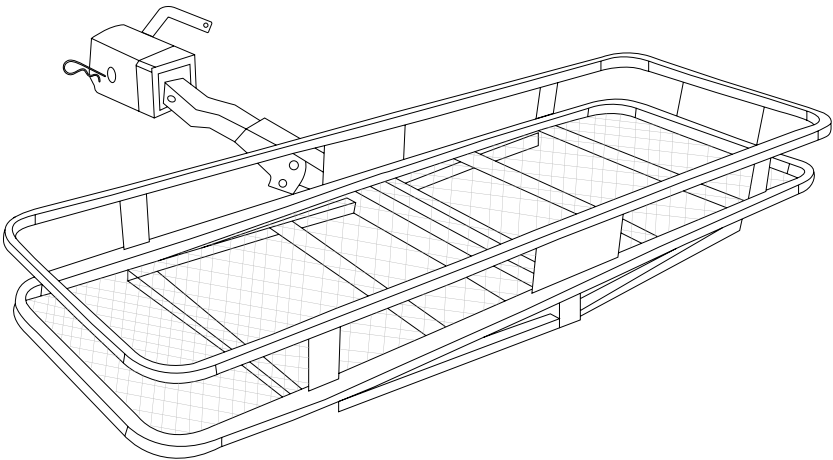

5. Adhere **(G)** Waterproof Reflective Stickers to the Platform.

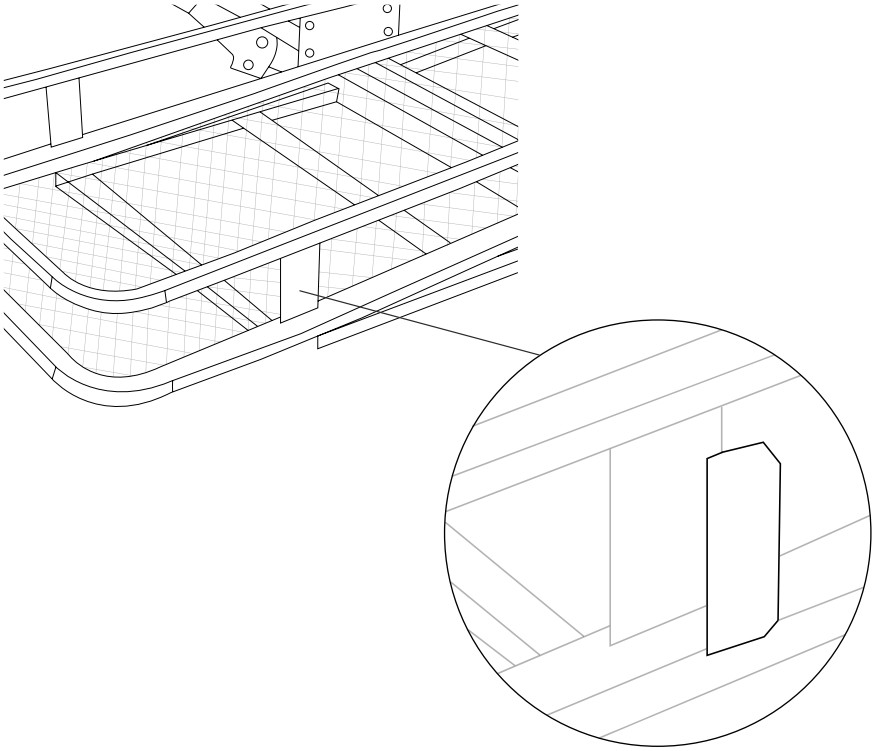

ALSO AVAILABLE FOR PURCHASE

RaxGo™ Cargo Carrier Bag

SKU: RXWPCCB

FEATURES:

- Heavy-duty, abrasion-resistant material stands up to the elements
- 100% waterproof coverage keeps your belongings secure
- Constructed of premium material with a 2" zipper flap
- Provides ample space for camping gear, luggage, and more
- Convenient collapsible design folds up for easy storage
- Safeguards your cargo from rain, snow, wind, sun, and dust

TECHNICAL SPECIFICATIONS

- Dimensions: 60" x 20" x 6"

WARRANTY INFORMATION

LIMITED WARRANTY ON RAXGO™ HITCH MOUNT CARGO CARRIER KIT

THIS LIMITED WARRANTY GIVES YOU SPECIFIC LEGAL RIGHTS AND YOU MAY ALSO HAVE OTHER RIGHTS, WHICH VARY FROM STATE TO STATE.

WE WARRANT THAT DURING THE WARRANTY PERIOD, THE PRODUCT WILL BE FREE FROM DEFECTS IN MATERIALS AND WORKMANSHIP.

LIMITATION OF LIABILITY

TO THE EXTENT NOT PROHIBITED BY LAW, THIS WARRANTY IS EXCLUSIVE AND IN LIEU OF ALL OTHER WARRANTIES, ORAL, WRITTEN, STATUTORY, EXPRESS OR IMPLIED. EXCEPT FOR THE EXPRESS WARRANTIES CONTAINED IN THIS LIMITED WARRANTY STATEMENT AND TO THE EXTENT NOT PROHIBITED BY LAW, WE DISCLAIM ALL OTHER WARRANTIES, EXPRESSED OR IMPLIED, STATUTORY OR OTHERWISE, INCLUDING WITHOUT LIMITATION, THE WARRANTIES OF MERCHANTABILITY AND FITNESS FOR A PARTICULAR PURPOSE. SOME STATES DO NOT ALLOW DISCLAIMERS OF IMPLIED WARRANTIES, SO THIS DISCLAIMER MAY NOT APPLY TO YOU. TO THE EXTENT SUCH WARRANTIES CANNOT BE DISCLAIMED UNDER THE LAWS OF YOUR JURISDICTION, WE LIMIT THE DURATION AND REMEDIES OF SUCH WARRANTIES TO THE DURATION OF THIS EXPRESS LIMITED WARRANTY.

OUR RESPONSIBILITY FOR DEFECTIVE GOODS IS LIMITED TO REPAIR, REPLACEMENT OR REFUND AS DESCRIBED BELOW IN THIS WARRANTY STATEMENT.

WHO MAY USE THIS WARRANTY? C&A Marketing, Inc. located at 114 Tived Lane East, Edison, NJ (“we”) extend this limited warranty only to the consumer who originally purchased the product (“you”). It does not extend to any subsequent owner or other transferee of the product.

WARRANTY INFORMATION

WHAT DOES THIS WARRANTY COVER? This limited warranty covers defects in materials and workmanship of the RaxGo™ Hitch Mount Cargo Carrier Kit (the “product”) for the Warranty Period as defined below.

WHAT DOES THIS WARRANTY NOT COVER? This limited warranty does not cover any damage due to: (a) transportation; (b) storage; (c) improper use; (d) failure to follow the product instructions or to perform any preventive maintenance; (e) modifications; (f) unauthorized repair; (g) normal wear and tear; or (h) external causes such as accidents, abuse, or other actions or events beyond our reasonable control.

WHAT IS THE PERIOD OF COVERAGE? This limited warranty starts on the date of your purchase and lasts for one year (the “Warranty Period”). The Warranty Period is not extended if we repair or replace the product. We may change the availability of this limited warranty at our discretion, but any changes will not be retroactive.

WHAT ARE YOUR REMEDIES UNDER THIS WARRANTY? With respect to any defective product during the Warranty Period, we will, at our sole discretion, either: (a) repair or replace such product (or the defective part) free of charge or (b) refund the purchase price of such product if an exchange unit cannot be provided.

HOW DO YOU OBTAIN WARRANTY SERVICE? To obtain warranty service, you must contact us at 1-833-722-0121 or by email at info@supportcbp.com during the Warranty Period to obtain a Defective Merchandise Authorization (“DMA”) number. No warranty service will be provided without a DMA number and return shipping costs to our facilities shall be assumed by you, the purchaser. Shipping costs of the replacement unit to you shall be assumed by us.



GET IN TOUCH!

**info@supportcbp.com
1-833-722-0121**

RAXGO is a trademark of C&A IP Holdings, LLC in the US.

All other products, brand names, company names, and logos are trademarks of their respective owners, used merely to identify their respective products, and are not meant to connote any sponsorship, endorsement or approval.

Distributed by C&A Marketing, Inc., 114 Tived Lane East, Edison, NJ 08837. Made in China.

© 2018. C&A IP Holdings, LLC. All Rights Reserved.