

LIFTKAR® PTR

POWERED TRACKED STAIRCLIMBER



INSTRUCTION MANUAL

SANO
makes life easier.



LIFTKAR® PTR

POWERED TRACKED STAIRCLIMBER

INTRODUCTION

CONGRATULATIONS!

WITH LIFTKAR PTR YOU RECEIVE A SAFE TRACKED STAIRCLIMBER. THE PURPOSE IS THAT IT HELPS YOU SAFELY CONVEY WHEELCHAIR USERS UP AND DOWN STAIRS.

The LIFTKAR PTR is a mobile unit that has been especially developed for operating on straight steps. Wheelchair users can now move around more freely and helpers no longer need to strain their backs on the stairs.

The LIFTKAR PTR can quickly be dismantled into two handy parts by shifting two levers: the base unit including rechargeable battery weighs approx. 28 kg, the handle unit approx. 11 kg. The LIFTKAR PTR ensures safe handling on the stairs. Regardless of whether you operate a professional mobility service or are a friend, relation or partner, we wish you much satisfaction in using this unit. This instruction manual is designed to help you learn how to use the LIFTKAR PTR.

In order to update you about product news as well as technical changes (e.g. options, accessoires) we ask you to register your product online.

<https://www.sano-stairclimbers.com/product-registration>



THE INSTRUCTION MANUAL DOES NOT REPLACE THE OBLIGATORY TRAINING PROVIDED BY AN AUTHORISED SPECIALIST.



LIFTKAR® PTR (incl. options headrest, backrest cushion and foldable wheelchair brackets)

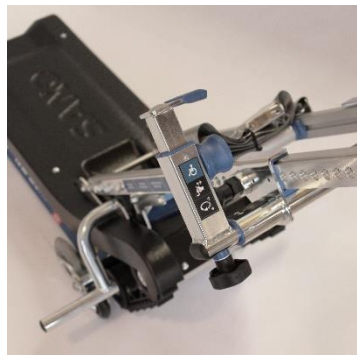
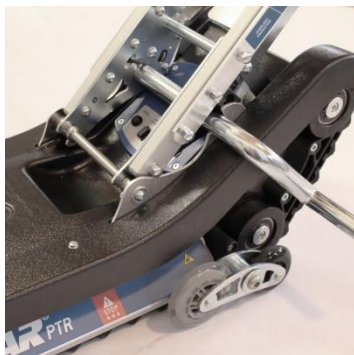

CONTENTS

(1) GENERAL SAFETY GUIDELINES	6
(2) PRODUCT DESCRIPTION	8
■ CONTROLS – HANDLE UNIT	10
■ CONTROLS – BASE UNIT	11
■ LIFTKAR PTR – INDIVIDUAL COMPONENTS	12
■ TECHNICAL DATA	13
■ INDICATORS AND CONTROLS	13
■ MAIN DIMENSIONS	14
(3) START-UP	16
■ FIRST STEPS	16
(4) OPERATION	19
■ ATTACHING THE WHEELCHAIR	19
■ OPERATION ON STAIRS	21
■ REMOVING THE WHEELCHAIR	23
■ USING THE TRACKED STAIRCLIMBER ON LEVEL SURFACES	24
■ TILTING ANGLE SENSOR	25
■ BATTERY STATUS WARNING	25
RECOMMENDATION FOR CHARGING THE BATTERY PACK	25
■ SAFETY RELEASE SYSTEM	26
(5) CLEANING & DISPOSAL	27
■ CLEANING AND DISINFECTION	27
■ DISPOSAL	27
■ RE-USE / SECOND-HAND USE	27
(6) WARRANTY & CUSTOMER SERVICE	28
■ MODIFICATION OF THE TRACKED STAIRCLIMBER	28
(7) WARRANTY & LIABILITY	29
■ WARRANTY	29
■ LIABILITY	29
(8) DECLARATION OF CONFORMITY	30
(9) NOTES	31

(1) GENERAL SAFETY GUIDELINES

- Please read this instruction manual carefully. Follow all instructions in this manual and take notice of the warning signs and pictograms on the unit. Climbing stairs presents a risk in itself and not complying with these instructions could cause accidents.
- The tracked stairclimber may only be used for the purpose for which it has been designed – transporting people on straight stairs.
- **The LIFTKAR-PTR must be operated by people who**
 - have proof of having been trained in how to operate the tracked stairclimber
 - can walk up stairs backwards
 - are both physically and mentally sound
 - are not under the influence of alcohol, drugs or medication
 - are able to maintain balance without great physical strain.
 - Children are not permitted to use the tracked stairclimber
- Never operate the LIFTKAR PTR on surfaces that are wet, slippery, polished or waxed, smooth, icy or generally do not give the operator sufficient stability, and impair the adhesion of the stairclimber tracks. Rugs and carpets can also present a risk.
- It is not possible to use the tracked stairclimber on spiral staircases or stairs with tight corners.
- Never use the LIFTKAR PTR on stairs at an inclination of more than 35°.
- Make sure that the stairs to be climbed are designed to bear the combined load of tracked stairclimber + wheelchair + weight of persons.
- Never operate the stairclimber on heavily damaged stairs (e.g. if the edges of the steps are worn away).
- Under no circumstances may you let go of the handle while operating the stairclimber on the stairs. Always operate the stairclimber with both hands.
- The LIFTKAR PTR is to be used exclusively for transporting people and suitable self-propelled wheelchairs. Your SANO specialist dealer can advise you on the suitability of your wheelchair.
- Never overload the device. The maximum load capacity (model-dependent) of the LIFTKAR PTR is 130 kg or 160 kg (weight of person + weight of wheelchair). Make sure that your wheelchair is designed to bear the weight of the person to be transported.
- The wheelchair must be in technically trouble-free condition (no damage to the frame etc., no missing or loose fittings, no modifications, tyres and brakes in good condition). If in doubt, contact your specialist dealer before using

- Make sure that nobody is below the unit while in operation on stairs.
- For transporting people using LIFTKAR PTR tracked stairclimbers, only use wheelchairs fitted with a safety belt or other personnel retention system.
- Passengers who are not able to sit securely will need to wear a belt.
- **Make sure you always wear closed, non-slip shoes when operating the LIFTKAR.**
- Do not use the LIFTKAR with a passenger until you have practised operating it perfectly without a payload. Next, try operating it again with somebody as lightweight as possible who is not disabled. The test passenger should hold onto a handrail or a second person during the climb.
- Never reach into the stairclimber tracks (risk of trapping/squashing)!
- To transport the device itself, we recommend dismantling the LIFTKAR PTR.
- The LIFTKAR PTR has a powerful 12Ah/24Volt rechargeable battery that should always be fully-charged before using the tracked stairclimber. If, for whatever reason, the battery pack should run out of power while in operation on stairs, immediately move the stairclimber down the stairs and fully recharge the battery. It is always possible to move down at least one flight of stairs, even with a rechargeable battery that is almost empty. The first sign of the battery pack running out is indicated by the stairclimber's performance. The LIFTKAR PTR becomes slower and appears to be struggling. Inexperienced operators are warned by the LED display: **if the battery pack needs to be recharged the LED display starts flashing, alternating between red and green and there is an intermittent acoustic warning signal.**
- Do not use the tracked stairclimber if unusual noises and/or vibrations occur while the LIFTKAR stairclimber is in operation. Withdraw the stairclimber from use and have it inspected by an authorised specialist.
- The following rules apply regarding ambient conditions for storing and operating the LIFTKAR tracked stairclimber: avoid exposing the tracked stairclimber to high temperatures such as direct sunlight or high air humidity as a consequence of using in a sauna area or in the rain, or similar, due to the risk of damaging the stairclimber as a result of overheating. Likewise, avoid exposing the tracked stairclimber to very low temperatures below 5°C. Do not use in the vicinity of sensitive medical equipment.

(2) PRODUCT DESCRIPTION



* options

CONTROLS - HANDLE UNIT

BACKREST CUSHION*

RETENTION BOLT



CONTROLS - BASE UNIT

FOLDABLE WHEEL CHAIR BRACKETS*



CONTROLS – HANDLE UNIT

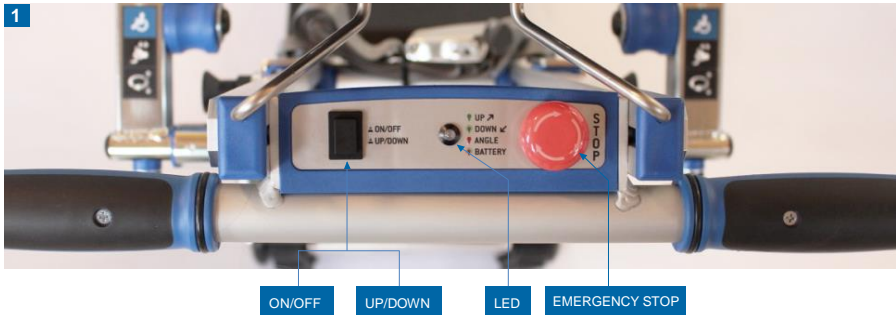

ON/OFF - UP/DOWN

- If the LIFTKAR PTR is switched off, switch it on by pressing this button. The LIFTKAR PTR automatically switches on in UP mode.
- The LED **illuminates green**.
- Press this button to switch to DOWN mode. LED **flashes green**.
- Press this button longer (approx. 2 seconds) to switch off the LIFTKAR PTR. After approx. 5 minutes of inactivity, the unit switches off automatically to save battery power.

LED

- Illuminates green in UP mode.
- Flashes green in DOWN mode.
- Changes to red if the stairs are too steep (36° - 40°). The speed of the LIFTKAR PTR is reduced automatically.
- A red light and an acoustic warning go on when the unit is overloaded, or the stairs are too steep. PTR stops.
- Flashing red and green and an acoustic warning go on if battery power is low.

EMERGENCY STOP

Stops the LIFTKAR PTR tracked stairclimber.
Reset the Emergency STOP by pulling or rotating the switch.

■ CONTROLS – BASE UNIT



KEY

The key protects the LIFTKAR PTR against unauthorised use.

ON/OFF

Same function as on handle unit.

WARNING

- Use only for loading purposes (e.g. stowing in car)

DRIVE

Starts the drive chain in the chosen climbing mode.

SPEED

Preselect switch for stair climbing speed

Speed I 4,5m/min

Speed II 5,5m/min

Speed III 6,5m/min

(2) PRODUCT DESCRIPTION

■ LIFTKAR PTR – COMPONENTS (SCOPE OF DELIVERY)



■ TECHNICAL DATA | LIFTKAR PTR

Maximum load: (incl. wheel chair)	130kg / 160kg
Minimum wheelchair width: (frame inside)	420mm
Max. inclination:	35°
Total weight:	39kg
Weight of base unit: (incl. batteries)	28kg
Range:	up to 1000 steps*
Minimum landing space:	970 x 970mm

* depending on overall weight to be transported

■ INDICATORS AND CONTROLS

BASE UNIT

- Keyswitch
- ON/OFF – UP/DOWN switch
- Speed selector switch I / II / III
- DC charging socket
- Main fuse

HANDLE UNIT

- ON/OFF – UP/DOWN switch
- Multi-function LED – battery status and inclination angle
- EMERGENCY STOP
- Activation button

(2) PRODUCT DESCRIPTION

■ MAIN DIMENSIONS

SIDE VIEW

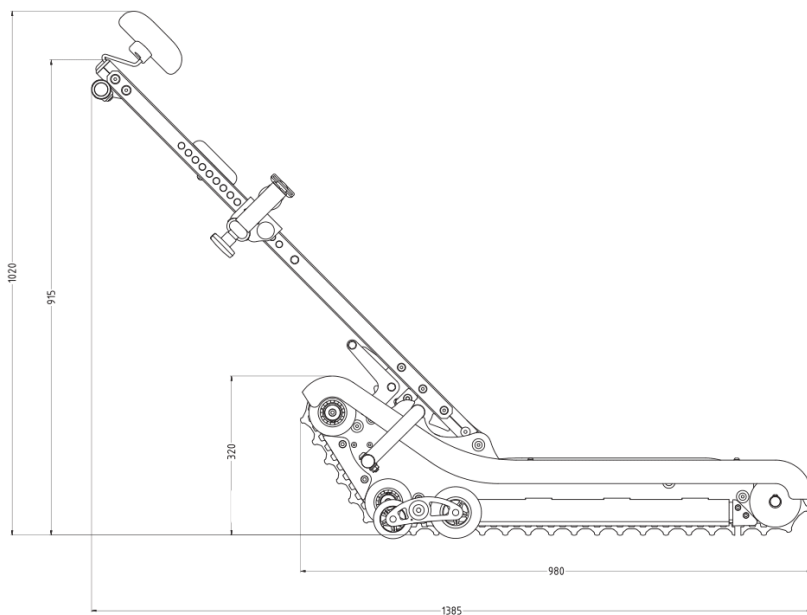

FRONT VIEW

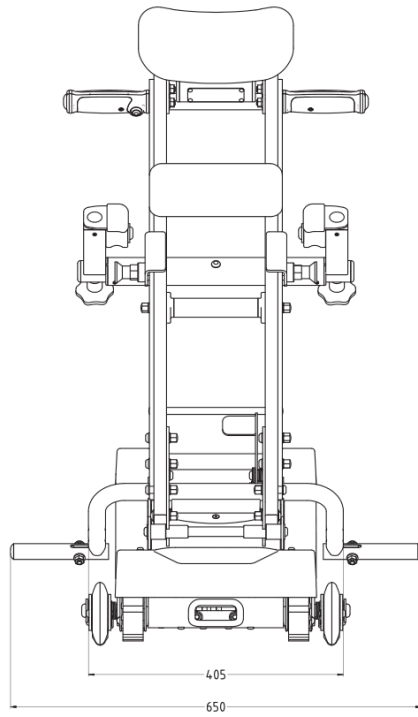

(3) START-UP

FIRST STEPS

(3.1) CHARGE BATTERY

Fully charge the 24V/12Ah battery pack installed in the base unit. This can take **up to 6 hours** depending on the residual charge. The charging socket is located on the back of the base unit.



Liftkar PTR is equipped with an inbuilt battery charger. During charging process a LED which you can find in the left side wall of the device chassis indicates the charging level:

Orange: charging process running

Green: charging process terminated, fully charged batteries



2a



2b



(3.2) INSERTING / LOCKING THE HANDLE UNIT TO THE BASE UNIT

Place the U-shaped yoke on the underside of the handle unit on the round support bar in the base unit (figure 2a). Make sure that the yoke engages with the grooves of the support bar (figure 2b). By pivoting the handle unit for-/ backwards the engagement is facilitated.

3a



(3.3) LOCKING THE HANDLE UNIT

Pivot the handle unit into the operating position. The spring loaded retention lever engages automatically. Additionally, the safety lug holds the retention lever in position.

WARNUNG

- Before operating the tracked stairclimber **always** control the position of the retention lever. The safety lug **must** be engaged!



(3.4) DETACHING THE HANDLE UNIT

Press the safety lug forward (figure 4a), subsequently draw the retention lever backwards into its lower limit position (figure 4b).



(3.5) REMOVING THE HANDLE UNIT

Pivot the handle unit forward and pull slightly upwards. Once the snap-in position is reached the handle releases itself automatically.

(4) OPERATION

■ (1) ATTACHING THE WHEELCHAIR

(4.1.1) PLACE WHEELCHAIR ON STAIRCLIMBER

Roll the wheelchair along the centreline of the base unit until the tyres of the wheelchair wheels touch the wheelchair support.



(4.1.2) PIVOT HANDLE UNIT TOWARDS WHEELCHAIR

Release handle unit and pivot it towards the wheelchair until the handle unit is approximately vertical (parallel to the wheelchair backrest).

(4.1.3) ADJUST POSITION OF WHEELCHAIR RETENTION BRACKETS

Position the wheelchair retention bracket directly underneath the bend in the wheelchair handle.

By pulling on both locking pins you can adjust the vertical position of the retention bracket to the height of the wheelchair.



(4.1.4) SECURING THE WHEELCHAIR

Adjust the position of the two slide blocks (to the left and right of the bracket) and fix them in place by tightening the two hand bolts.

Adjust the headrest and pivot the handle unit back into the operating position.

Keep both your hands on the handle unit while you do this. The spring loaded retention lever automatically moves into its front limit position.

i NOTE

- Make sure that the safety lug has engaged properly.
- Apply the brake on the wheelchair!

⚠ WARNING

- Never leave the person to be conveyed in this position unattended.

(4) OPERATION

■ (2) OPERATION ON THE STAIRS

(4.2.1.) SWITCHING ON

Switch on the tracked stairclimber using the keyswitch and the ON/OFF button.

The tracked stairclimber is automatically set to move UP. The LED is illuminated permanently green.



(4.2.2) MOVING UP

Position the tracked stairclimber (figure 2a) so that it is at an angle of 90° to the stairs.

Always hold the handle unit securely with both hands. Use the direction selector switch on the handle unit display to select "UP" (figure 2b). The LED illuminates permanently green.



Stand behind the handle unit of the tracked stairclimber as instructed during training by authorised personnel. Press the activation button on the right handle (figure 2c).

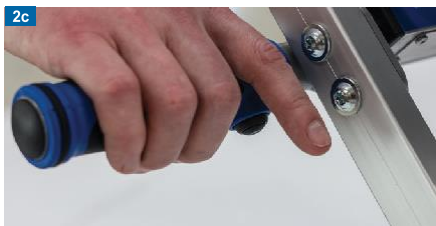

WARNING

- Never move on stairs with an inclination of more than 35° and during operation the handle unit must always be held with both hands.
- Always move on stairs at an angle of 90° (length of tracked stairclimber to steps).
- The integrated angle sensor (angle LED) is designed merely as an indicator and does not represent a safety feature.

(4.2.3) REACHING THE TOP STEP

Stop the tracked stairclimber as soon as the „STOP“ marks on the side have reached the edge of the top step (figure 3).

Now gradually tilt the tracked stairclimber back until the tracks rest on the floor of the landing. Press the activation button again. The tracked stairclimber then finishes moving onto the landing.



WARNING

- Before operating the tracked stairclimber it must be at an angle of 90° to the stairs.

(4.2.4) MOVING DOWN

Position the tracked stairclimber at an angle of 90° to the stairs so that the passenger is facing the stairs. Use the direction selector switch on the handle unit display to select „DOWN“ (figure 4). LED flashes green.

Hold the handle unit securely with both hands and press the activation button to move the tracked stairclimber towards the stairs until the „STOP“ mark on the side reaches the edge of the top step. Stop the tracked stairclimber and, using both hands, tilt the handle unit forward until the stairclimber tracks rest on the steps. Then press the activation button to continue moving down the stairs.

(4) OPERATION

(4.2.5) SAFETY CHECK

Although the tracked stairclimber is equipped with an angle warning LED, we recommend checking the precise inclination of the stairs before climbing them for the first time.

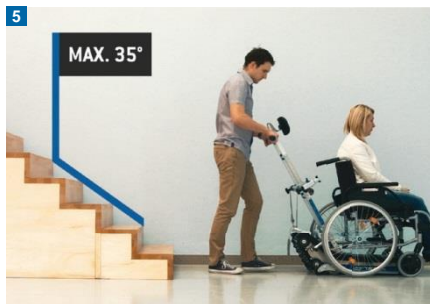

(3) REMOVING THE WHEELCHAIR

(4.3.1) RELEASING

Release the safety lug (figure 1a) and move the retention lever into the rear position (figure 1b).

Pivot the handle unit carefully towards the wheelchair until the wheelchair reaches the ground and the handle unit is in a vertical position. Then undo the manual bolts and pull both retention blocks to the side out of the wheelchair backrest.

i NOTE

- Perform this procedure only on horizontal ground, well away from the stairs.



■ (4) USING THE TRACKED STAIRCLIMBER ON LEVEL SURFACES

(4.4.1) MOVING ON LEVEL SURFACES

In order to move the wheelchair on the tracked stairclimber or to turn the combination on landings, push the handle unit slightly downwards (figure 1).

This raises the stairclimber tracks so that the tracked stairclimber can be shifted on the rear left-hand and right-hand side wheel units.



(4.4.2) BASE UNIT FUNCTIONS

The following controls are located on the rear side of the base unit:

- Combined ON/OFF, UP/DOWN switch
- Keyswitch
- Speed selector switch

It is possible to operate the base unit without the handle unit. In order to use this function, it is necessary that the retention lever is in the lower limit position (figure 2b). This mode of operation is provided exclusively for loading the base unit and for service activities.

The base unit is operated using the ON/OFF button. After switching on, the base unit is automatically set to Move UP mode. Pressing the ON/OFF button again switches the unit to the Move DOWN mode. Pressing the ON/OFF button for a longer period switches the unit off.

Use the speed selector switch to choose between one of three speed settings.

(4) OPERATION

■ TILTING ANGLE SENSOR

Your LIFTKAR PTR is equipped with a tilting angle sensor, which detects the inclination of the LIFTKAR PTR on stairs. In the case that the stair angle exceeds 35°, the device clearly reduces its driving speed and the LED on the handle unit illuminates permanently red. In the event of an extreme stair angle, the unit stops climbing upstairs. (A warning tone as well as the red illuminated LED signals this condition.)

It is still possible to move downstairs in creep speed in order to bring the PTR out of the danger zone onto the next landing.

- Never move on stairs with an inclination of more than 35°.
- The integrated tilting sensor does not substitute a check of the stair angle by the operator before the first movement.

■ BATTERYSTATUS WARNING

In case of low battery level the LED on the handle unit starts flashing red/ green, as well as an alternating warning tone alerts the operator. It is still possible to drive 3-4 levels after the first alert.

■ RECOMMENDATION FOR CHARGING THE BATTERY PACK

The lead gel cells inside the battery pack are maintenance-free, gas-tight and rechargeable. Their service life depends largely on the number of charging/discharging cycles. For example, it is possible to partially discharge lead batteries 1000 times, drawing more than 200 times the full capacity of the battery, providing the battery is never fully discharged.

- Avoid discharging the battery completely. Charge the battery pack as often as possible.
- Lead batteries are susceptible to self-discharging. The battery pack also needs to be looked after in that it must always be fully-charged. Completely discharging the battery will shorten its service life. Lead-gel cells have a long service life if they are regularly fully charged as soon after use as possible. That is why the battery pack should be connected up to the power connector cord after each use.
- Falls die Bleibatterien doch einen Schaden bekommen haben, können diese bei autorisierten SANO Fachhändlern gewechselt werden. Die alten Bleibatterien sind voll recyclingfähig und sind kein Sondermüll. If the batteries should become damaged it is possible to have them replaced in a workshop of authorized SANO partners. The old lead batteries are fully recyclable and are not to be disposed of.
- The ideal temperature for charging is between 20 and 25° C. Temperatures that are too cold or too hot will affect the battery's capacity.

i NOTE

- if the battery pack is not fully charged, or it loses its charge suddenly, not only will the speed of the Liftkar PT be slower, but its capacity is reduced as well. This means that overload mode may be reached even with a relatively light load.

SAFETY RELEASE SYSTEM

The safety release system is positioned on the left side of the base unit (figure 1). In the event of an unpredictable machine break down (e.g. technical defect, power supply failure), this system allows the operator to manually move down the tracked stairclimber onto the next landing. By pulling the safety release wire, the electromagnetic brake is disengaged manually. Due to its own weight (incl. wheelchair + weight of person) the LIFTKAR PTR starts moving downstairs.



ATTENTION:

- Before activating the safety release system always press the emergency stop button and remove the key.
- Safety first - if safety release system is required, make sure that a second person (helper) is present, who activates the safety release system.
- By pulling the safety release wire (helper) and pressing the handle unit downwards (operator), the device starts moving.
- The device can be stopped anytime by releasing the safety release wire.
- Only move the stairclimber onto the next landing.
- After usage of the safety release system your LIFTKAR PTR must undergo a complete safety check by an authorised SANO partner.

(5) CLEANING & DISPOSAL

■ CLEANING AND DISINFECTION

Our motto is:

A CLEAN MACHINE MOVES MORE SMOOTHLY.

- Cleaning with a standard household detergent is quite sufficient.
- Never use a high pressure cleaner or similar.
- If required, the surfaces can be cleaned with a commercially available alcohol-based equipment disinfection agent (such as Sagrotan®).

■ DISPOSAL

The LIFTKAR PTR tracked stairclimber is a durable product. At the end of their useful life, the tracked stairclimber components and charger should be disposed of properly.

- The tracked stairclimber does not contain any hazardous materials and is fully recycling-compatible. The printed circuit boards and battery pack must be handed over to specialist recyclers.
- Do not dispose of the battery pack in household waste.
- Correct and comprehensive disposal of the tracked stairclimber can be processed and invoiced for by the manufacturer.

■ RE-USE / SECOND-HAND USE

- Before re-using the stairclimber or using it second-hand, make sure it undergoes a safety check and cleaning as per manufacturer's instructions by specialist personnel.
- All operators must have proof of having been trained in how to operate the stairclimber.

(6) WARRANTY & COSTUMER SERVICE

■ MODIFICATION OF THE TRACKED STAIRCLIMBER

- Modifications of any kind are not permitted and make void all liability and warranty claims to the manufacturer.
- Modifications to the tracked stairclimbers may only be made by the manufacturer.

RECOMMENDED BY SANO!

In order to ensure an extended service life of the tracked stairclimber, we recommend having the tracked stairclimber serviced at regular intervals by an authorised SANO dealer. Please contact your SANO dealer for more information.



(7) WARRANTY & LIABILITY

■ WARRANTY

The warranty period for the climbing unit and handle unit on all models of the LIFTKAR PTR tracked stairclimber is 24 months. Battery packs have a warranty period of 6 months. In both cases the warranty period starts on the day the product is handed over to the customer.

The following are excluded from the warranty:

- parts subject to natural wear and tear
- damage that occurs from using the unit for a purpose it was not intended
- unauthorised modifications to the unit or accessories
- maintenance work required due to continuous operation
- faults occurring due to incorrect operation and/or failure to comply with the instruction manual, accidents, negligent or violent damage, damage due to fire and water, force majeure and other causes outside our control.

■ LIABILITY

SANO Transportgeräte GmbH is not liable as manufacturer for any damage, if:

- the LIFTKAR PTR is used for a purpose for which it is not intended.
- the LIFTKAR PTR is not serviced regularly (at least once in two years) by SANO or one of our authorised specialists.
- the instructions in this manual are not complied with.
- non-SANO components are fitted or linked to the LIFTKAR PTR.
- original components are removed.



Please contact us for a list of authorised SANO service centres.

(8) DECLARATION OF CONFORMITY

SANO Transportgeraete GmbH takes sole responsibility in declaring that LIFTKAR stairclimbers comply with the following principle requirements

- The medical device directive 93/42/EEC, Annex I
- The electromagnetic compatibility directive 2004/108/EC
- The health and safety specifications in the machinery directive 2006/42/EC, Annex IIA

Any changes made to the product without our prior consent render this declaration void.

Relevant standards:

EN 12182	Assistive products for persons with disability – General requirements and test methods
DIN EN ISO 14971	Risk analysis
DIN EN 1041	Information provided by the manufacturer + Annex I of a medical product
ISO 7176-28	Wheelchairs - Parts 28: Requirements and test methods for stair-climbing devices
ÖNORM EN 12100	Safety of machinery – terms, general principles for design
DIN EN ISO 13485	Medical products – Quality management systems
DIN EN ISO60601-1-11	Medical electrical equipment Part 1-11: General equipments for basic safety and essential performance – Collateral Standard: Requirements for medical electrical equipment and medical electrical systems used in the home healthcare environment.
DIN EN 62366	Medicine devices – Applications of usability engineering to medical devices
EN 980	Symbols for labelling medical devices.

SANO Transportgeraete GmbH
Am Holzpoldlgut 22
4040 Lichtenberg / Linz
Austria

Tel. +43 7239 / 510 10 | Fax +43 7239 / 510 10 14 | office@sano.at
www.sano.at

SANO Deutschland GmbH
Geigelsteinstraße 10
83080 Oberaudorf
Germany

Tel. +49 8033 / 308 96 0 | Fax +49 8033 / 308 96 17 | info@sano-treppensteiger.de
www.sano-treppensteiger.de

SANO UK Powered Stairclimbers Ltd.
Bristol Court, Betts Avenue
Martlesham Heath
Ipswich, Suffolk / IP5 3RY, England

Tel. +44 1473 / 333 889 | Fax +44 1473 / 333 742 | info@LIFTKARdirect.com www.liftkardirect.co.uk



Subject to changes without notice / LIFTKAR PTR 2018-08, Rev 04

www.sano-stairclimbers.com