

# 38" w x 24.5" h Side Hinge

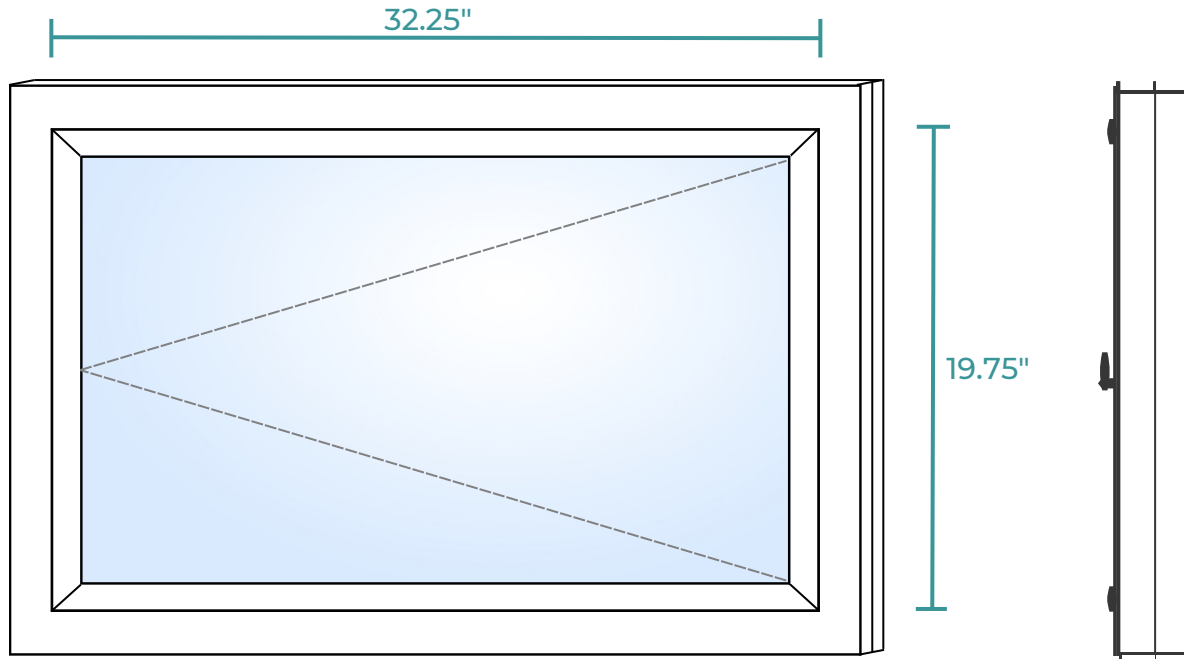

Recommended Rough Opening: 39" w x 25.5" h



Measurement	Dimension	Area	Frame Thickness
Window Frame	38" w x 24.5" h		3.25"
Clear Opening	32.25" w x 19.75" h	4.04 Sq. Ft.	
Visible Glass	30.75" w x 17.25" h	3.34 Sq. Ft.	

## Component Details

PVC frame and sash with mitre cut welded corners  
Aluminum lock and keeper mechanisms  
Steel frame and sash hinge brackets  
Removable spring-loaded insect screen

## Glass Details

Double Pane  
Argon Gas Filled  
Low-E 180 Coating  
U-factor: 0.22\*

In-swinging | can be left or right hinged

## Testing Details

Forced-entry Resistance Test (ATSM F588)  
F10 Rating

Thermoplastic Corner Weld Test (Clause 9.3.6.2)  
Pass

## Air Leakage Resistance Test (ATSM E283)

R class A3 Level  
Infiltration = 0.038 cfm/ft<sup>2</sup> - A3 Level  
Exfiltration = 0.047 cfm/ft<sup>2</sup> - A3 Level

## Water Penetration Resistance Test (ATSM E547)

No Leakage or trapped water at 260 Pa  
Water Application Rate: 1.492 L/min

\*To mitigate against supply chain disruptions, we source glass from multiple suppliers. There may be a slight difference in the U-factor depending on the glass used in each unit.