

# Tilt Back Tire Changer Bead Blaster

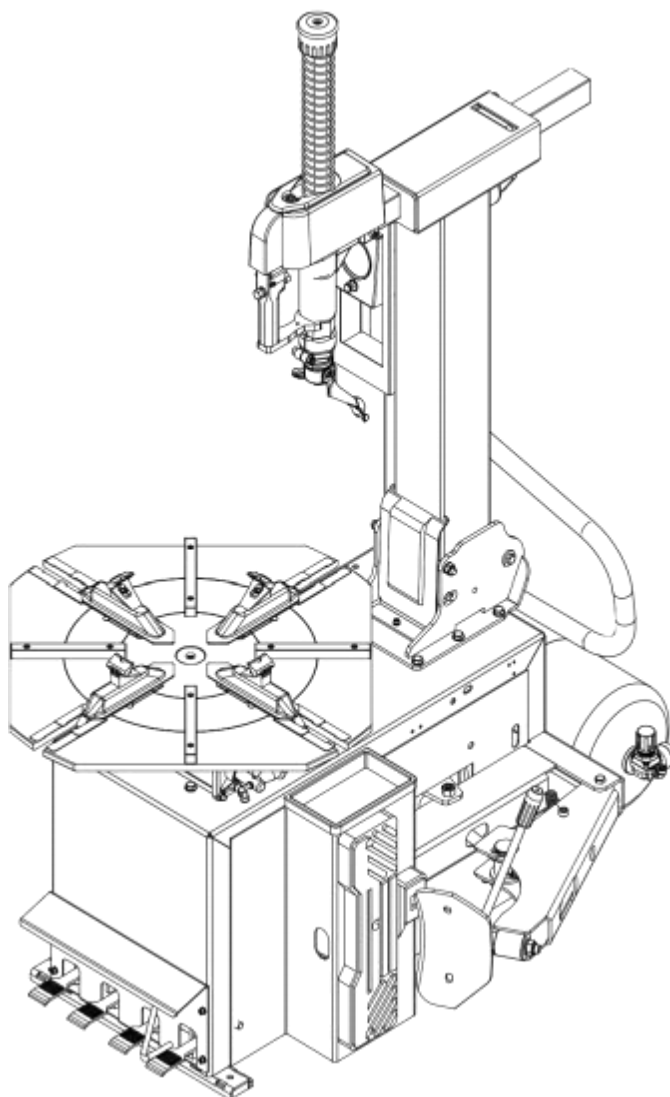

- First, we should confirm the integrity of the product before installing and debugging, to ensure that the product has not been changed.
- The manual is a part of the product, please put it in the place where you can find it at any time .
- In the installation process, if the warning signs are damaged, contact the manufacturer in time to replace the defect.

**WARNING - Risk Of Explosion.** This Equipment Has Internal Arcing Or Parking Parts Which Should Not Be Exposed To Amenable Vapors.

Do Not Use Below Garage Floor or Grade Level.

**ATTENTION - Risque d, explosion.** Cet d quipement possdde un arc intdrieur ou des pidces de stationnement qui ne doivent pas dtre exposes aux vapeurs inflammables.

Ne pas utiliser au- dessous du plancher de garage ou niveau de grade.

# GROUNDING INSTRUCTIONS

## 1 All grounded, cord-connected tools

- ❖ In the event of a malfunction or breakdown, grounding provides a path of least resistance for electric current to reduce the risk of electric shock. This tool is equipped with an electric cord having an equipment-grounding conductor and a grounding plug.
- ❖ The plug must be plugged into a matching outlet that is properly installed and grounded in accordance with all local codes and ordinances.
- ❖ Do not modify the plug provided - if it will not fit the outlet, have the proper outlet installed by a qualified electrician.
- ❖ Improper connection of the equipment-grounding conductor can result in a risk of electric shock. The conductor with insulation having an outer surface that is green with or without yellow stripes is the equipment-grounding conductor. If repair or replacement of the electric cord or plug is necessary, do not connect the equipment-grounding conductor to a live terminal.
- ❖ Check with a qualified electrician or service personnel if the grounding instructions are not completely understood, or if in doubt as to whether the tool is properly grounded.
- ❖ Use only 3-wire extension cords that have 3-prong grounding plugs and 3-pole receptacles that accept the tool's plug.
- ❖ Repair or replace damaged or worn cord immediately.

## 2 Grounded

- ❖ Cord-connected tools intended for use on a supply circuit having a nominal rating less than 150 V: This tool is intended for use on a circuit that has an outlet that looks like the one illustrated in Sketch A in Figure 83. 1. The tool has a grounding plug that looks like the plug illustrated in Sketch A in Figure 83. 1. A temporary adapter, which looks like the adapter illustrated in Sketches B and C, may be used to connect this plug to a 2-pole receptacle as shown in Sketch B if a properly grounded outlet is not available. The temporary adapter should be used only until a properly grounded outlet can be installed by a qualified electrician. The green-colored rigid ear, lug, and the like, extending from the adapter must be connected to a permanent ground such as a properly grounded outlet box.

## 3 Permanently connected tools

- ❖ This tool should be connected to a grounded metal permanent wiring system; or to a system having an equipment-grounding conductor.

Table 83.1  
Minimum gage for cord

Ampere Rating		Volts	Total length of cord in feet			
			25ft	50ft	100ft	150ft
more than	not more than	120V	50ft	100ft	200ft	300ft
		240v				
			AWG			
0	6		18	16	16	14
6	10		18	16	14	12
10	12		16	16	14	12
12	16		14	12	Not Recommended	

\* Only the applical parts of the table need to be included for instance, a 120-V product need not include the 240-V heading.

Figure 83.1  
Grounding methods

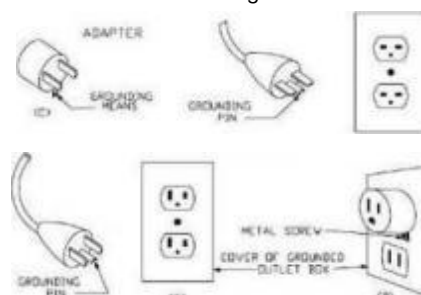

# Directory

Overview.....	4
1. 1 Important notes.....	4
1.2 Qualified users.....	4
1.3 Notes.....	4
1.4 Danger warning signs.....	5
1.5 Noise standard.....	5
Equipment description.....	6
2. 1 Product introduction.....	6
2.2 Technical parameters.....	6
2.3 Transport.....	6
2.4 Figure and part name.....	7
Installation and commissioning instructions.....	9
3. 1 Installation Preparation.....	9
3.2 Precautions during installation.....	10
3.3 Main installation procedure.....	10
3.4 Check the project table after installation.....	13
3.5 Commissioning and debugging.....	13
Operation declaration.....	14
4. 1 Operating notes.....	14
4.2 Disassembly operation process.....	14
Inflation .....	23
5. 1 Stage of Inflation.....	25
5.2 Bead Sealing.....	25
5.3 Tire of Inflation.....	27
Maintenance .....	28
6. 1 Maintenance.....	28
6.2 Storage and scrap.....	3 1
Fault causes and Solutions .....	32
Current Switch Diagram .....	33
Explosion drawing .....	34
Pnumatic Assist Arm .....	49

# Overview

## 1.1 Important notes

1.1. 1 Thank you for your purchase and use of this product. Please read and follow the safety instructions. Keep them readily available for machine operators.

1.1.2 Service and maintain the unit only with authorized or approved replacement parts .

## 1.2 Qualified users

1.2. 1 Make sure all operators are properly trained, know how to safely and correctly operate the unit, and are properly supervised.

1.2.2 Electrical appliances must be operated by the normal electrician.

1.2.3 Do not attempt to operate this equipment if you have never been trained on basic tire service and mounting / dismounting procedures.

## 1.3 Notes

1.3. 1 Before using the product, please carefully read every part of the manual, especially the operation of the safety and mechanical maintenance of the part.

1.3.2 Use the tire assembly machine must be operated by professional training personnel.

1.3.3 Tire disassemble is forbidden to use in explosive gas.

1.3.4 Before the machine is connected, the user must ensure that the use of power and gas supply and mechanical requirements, the circuit system must be operated by professional staff.

1.3.5 In the operation process, do not face close to the turntable, so as to avoid dust and other debris hit the operator's eyes. In order to ensure safety, mechanical operation, to be careful, do not touch the inflatable pedal, so as to avoid accidents.

1.3.6 To operate tire inflation must be very careful, strictly according to the instructions for operation, if the tire suddenly burst, tire assembly machine design and structure is not to protect the operator's personal safety (or any mechanical in the vicinity of the kind).

1.3.7 Operation of the tire changer, necklace, loose clothing, etc., may give the operator to bring personal injury.

1.3.8 In the process of removing or installing the operation of the tire, the turntable has always been to ensure that the clockwise rotation; if there is a counter clockwise rotation indicates that the turntable is a failure or operator error.

1.3.9 Manufacturers are responsible for the damage caused by the use of other parts of the manufacturer or the damage of the safety device.

1.3. 10 periodically check the oil mist, oil, if the oil level is low and need to unscrew the oil cup and then add. Oil mist using models for ISO Hg and viscosity for ISO vg32 oil mist special oil (such as: Es-so Fe-dis k32, 1405, Mobil Valvoline, KLUBER32)

1.3. 11 if the product is not used for a long time, please user A. disconnect all power supply, B. and lubricate the turntable fixture slide to prevent oxidation.

1.3. 12 when deciding to scrap equipment, to determine the total energy of all the energy to be cut off, according to the relevant laws and regulations for all non-ferrous metals and non-ferrous metal scrap processing.

### 1.4 Warning signs

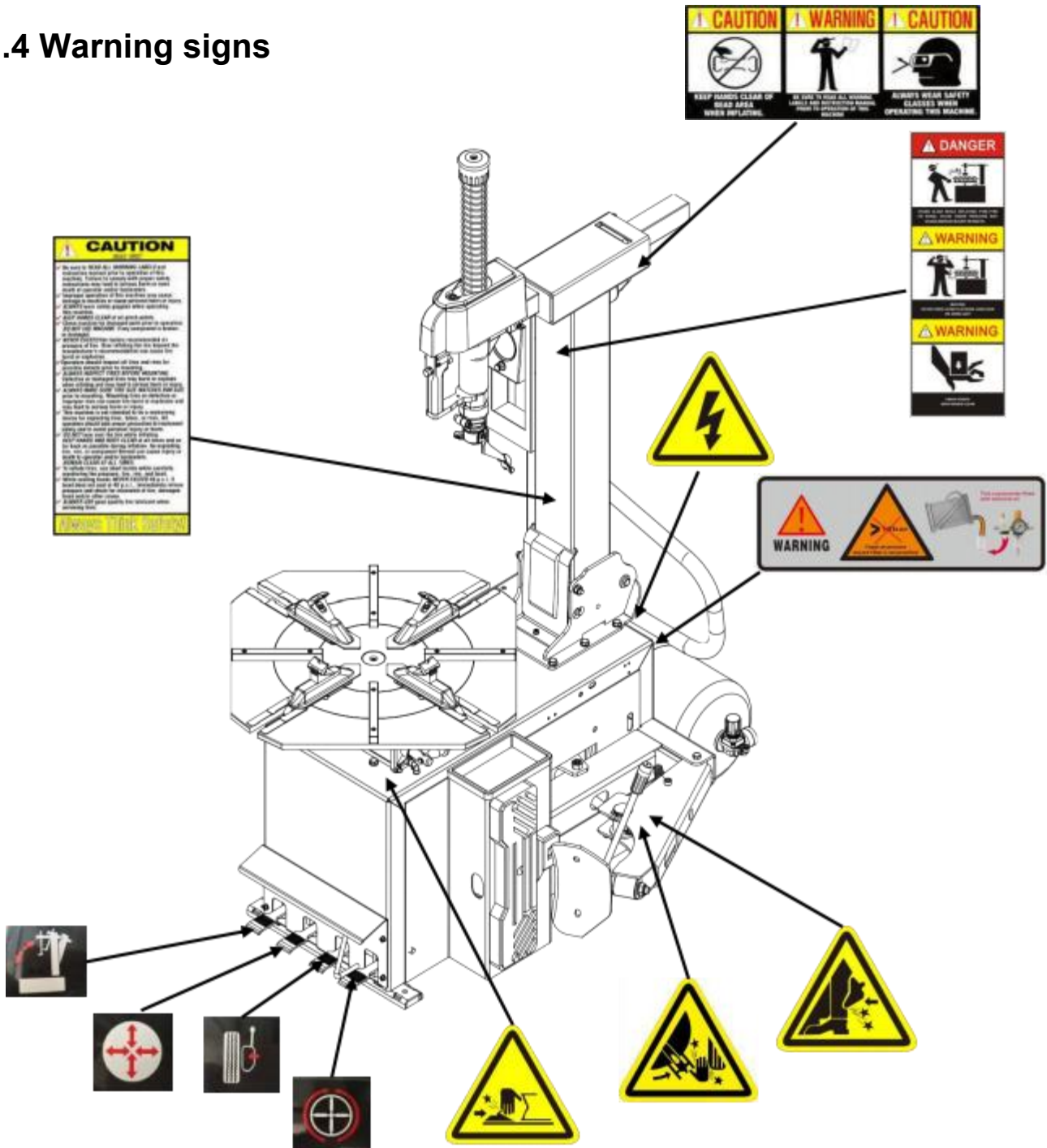

### 1.5 Noise standard

The noise of the tire changer shall be less than 70dB. for your health, and it is recommended that you place a noise meter in your operating area.

# Equipment description

## 2.1 Product introduction

This semi-automatic tire changer, is a semi- automatic, convenient and quick disassembled and installation of wheel size of 12" to 28" , the Maximum tire width is 15" and the diameter of the tire is 45" .

## 2.2 Technical parameters

Special points	Technical parameters
Outer rim	12"–26"
Inner rim	14"–28"
Maximum tire diameter	45"
Maximum tire width	14"
Pressing force (10bar)	2500kg
Operating air pressure	116–145psi
Maximum charge pressure	50psi
Power supply voltage	120V/60Hz 1ph
Motor power	2HP
Outline dimension	1 130*890*990mm
Net weight	265kg
Working state noise	<70dB (A)

## 2.3 Transport

Handling of the machine must be performed only with an appropriate lifting device such as a forklift or pallet jack. Only personnel who are experienced and qualified on material handling procedures should handle any transportation or moving of machine..

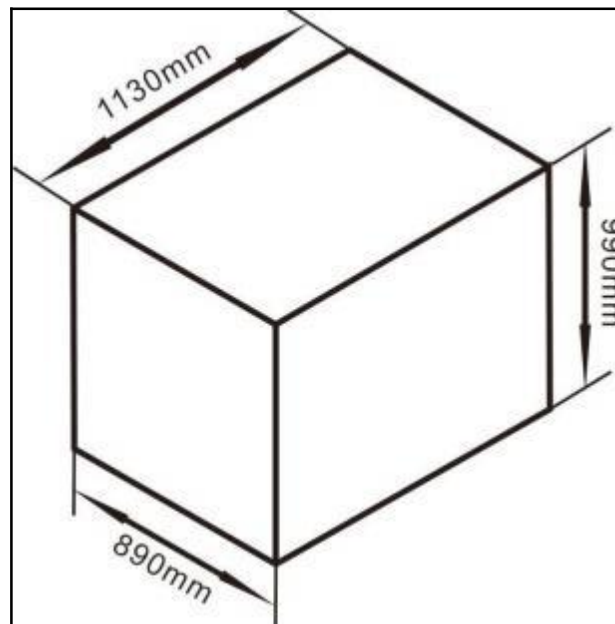

## 2.4 Figure and part name

A: Inflatable

B: Locking Handle

C: Vertical Reverse Spring

D: Push and pull arm

E : Tower

F : Mounting / Dismounting head

G : Wheel Clamp

H: Turntable

I: Bead Blaster

J: Lean back

K: Wheel Clamp Pedal

L : Bead Breaker Pedal

M: Turntable Pedal

N: Bead Breaker Pad

O : Bead Breaker

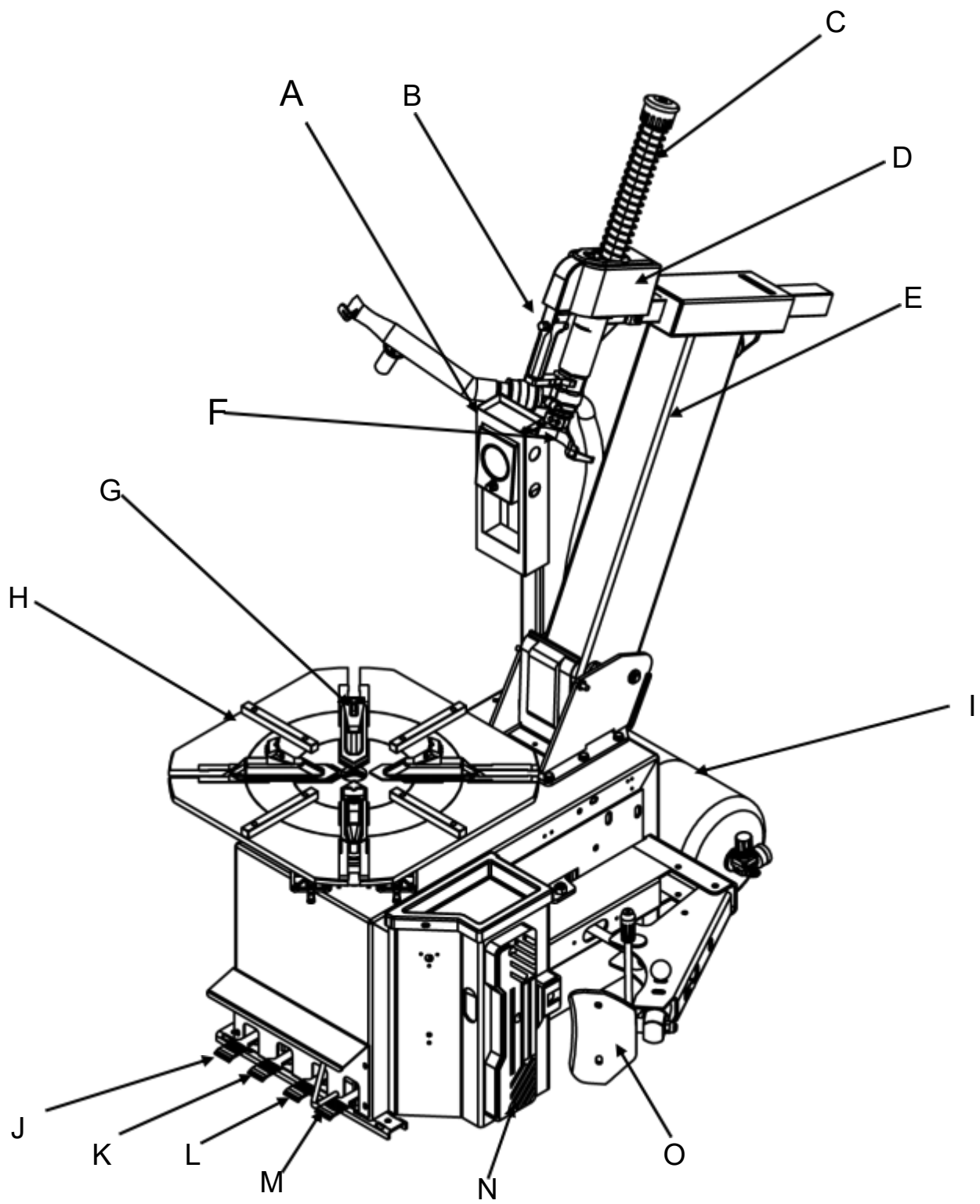



# Installation and commissioning instructions

## 3.1 Installation Preparation

### 3.1.1 installation location

- The area should provide the operator with enough space to use the equipment in a safe manner. (See Fig. 1, Fig.2)
- The area selected should be well lit, easy to clean and should be away from oil, grease, brake lathe chips, etc. Avoid areas where bystanders and customers may be present.
- Equipment installation location should be at least up to the standard shown in Fig.3 , which can ensure the normal operation and the machine parts are not subject to any restrictions. The tire changer is forbidden to use in explosive gas.

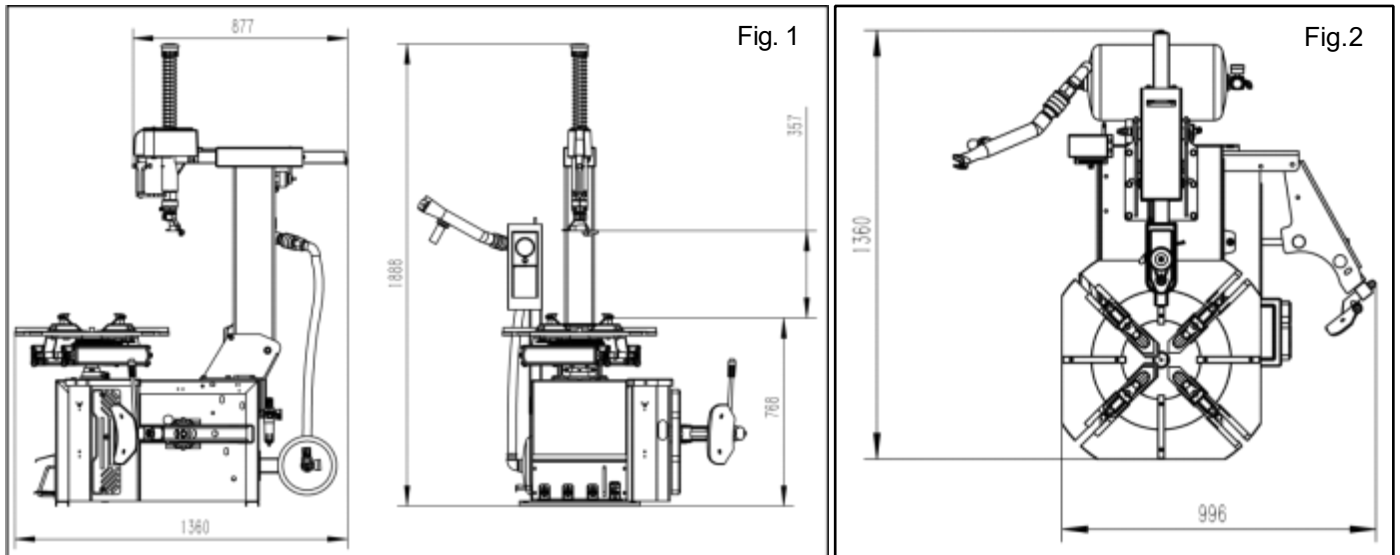

### 3.1.2 Installation equipment and tools

- ◇ Installation equipment and tools

### 3.1.3 Inspection products

- ◇ The shipment should be thoroughly inspected as soon as it is received. The signed Bill of Lading is acknowledgement by the shipping carrier as receipt of this product as listed in your invoice as being in a good condition of shipment. If any of these goods

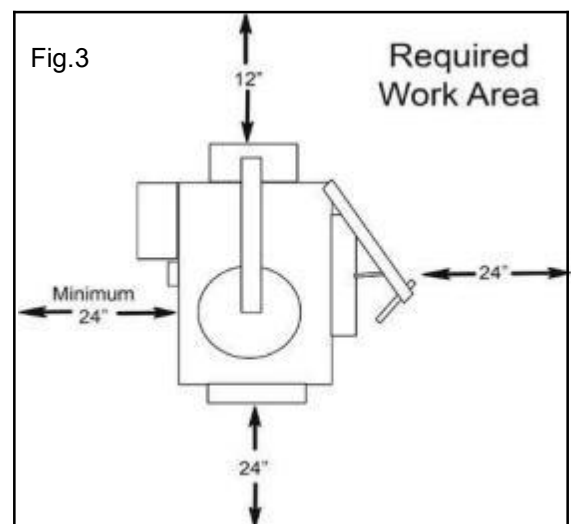

listed on this Bill of Lading are missing or damaged, do not accept goods until the shipping carrier makes a notation on the freight bill of the missing or damaged goods. Do this for your own protection.

### 3.1.4 Unpacking

- ◇ Check the packaging damage and the rain and other damage phenomenon, using the tool unpack the packing as shown in Picture, please dispose of packaging box, lest the environmental pollution.
- ◇ Check the condition of the machine, in accordance with the packing list to check if there is any damage or lost, once found contact the dealer and manufacture

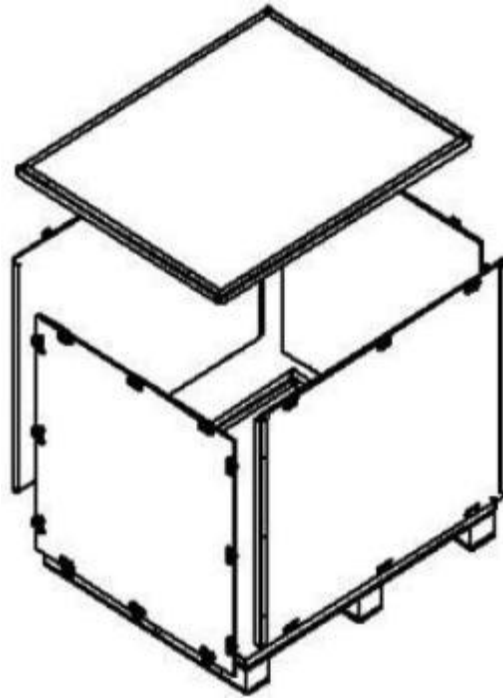

immediately. If you find that the leakage but still installed, we will not assume any responsibility. If you have any questions, please do not use the machine, the supplier contact.

### 3.2 Precautions during installation

- ◇ All bolts must be tightened.
- ◇ Power cord, no broken skin, no broken pipe, and other damage.

### 3.3 Main installation procedure

#### 3.3.1 Standard configuration installation

- ◆ The first step: Remove the Tilt Tower Main Pivot from the Tilt Tower Base before starting as shown in Fig. 4
- ◆ The second step: Take off screws as shown in Fig. 5.
- ◆ The third step: Take off screws as shown in Fig 6.
- ◆ The fourth step: Insert the Main Pivot Pin through the holes in the Tilt Tower Base and tight the screws. Ensure to match the teeth and the teeth insert into the holes, and tight the screws on both sides as shown in Fig 7( 1), Fig 7(2) and Fig7(3).
- ◆ Make sure to tight the screws as shown in Fig 8.
- ◆ Insert and connect all air pipes as shown in Fig 9.

◆ Fix and tighten the center column tower screw and equip the plastic cover as shown in Fig 10.

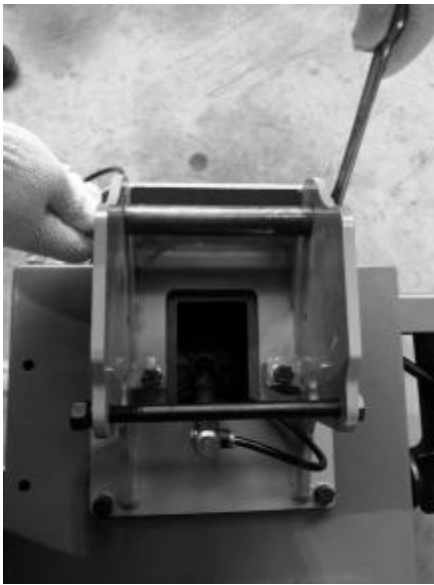

Fig 4

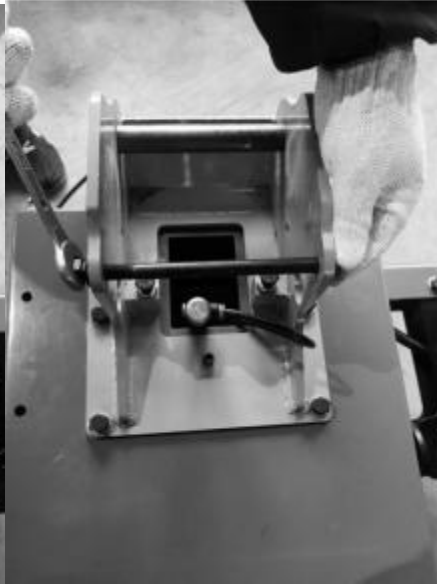

Fig. 5



Fig. 6



Fig. 7(1)



Fig. 7(2)



Fig. 7(3)



Fig. 8



Fig. 9



Fig. 10(1)



Fig. 10(2)

### 3.3.2 Bead Blaster installation



- ◆ Step One: Connect power supply connectors to position A
- ◆ Step Two: Tighten Screws in position B

### 3.4 Check the project table after installation

No.	Inspection item	Yes	No	Remarks
1	Whether the power supply voltage is consistent with the requirements of the equipment			
2	Whether the components are installed correctly			
3	Whether the bolts, screws, nuts are tightened			

**Note:** Please fill in the inspection item list after the installation is finished.

### 3.5 Commissioning and debugging

#### 3.5.1 Commissioning

- ◇ After the installation of the machine but before the connection with the power supply, it is necessary to determine the user's power supply, the gas source and the requirements of the machine is consistent.
- ◇ The machine is connected to the circuit, the circuit must be fitted with a fuse that is in line with the operating rules. The automatic circuit breaker of 25A is required to be operated by professional personnel. The power plug of the tire changer is provided with the customer.
- ◇ The compressed air system is connected to the machine by a pipe joint on the right side of the tank.

#### 3.5.2 Debugging

- ◇ Step 1: turn on the power and gas supply, depress the Turntable Rotation pedal, turntable should be clockwise. Raise the Turntable Rotation pedal, the turntable should be anti-clockwise rotation. (If the turntable is opposite to the specified rotation direction, the position of the two lines in the three-phase plug should exchange position.)
- ◇ The second step: depress the Bead Breaker Pedal, start the Bead Breaker device; when the pedal is released, the Bead Breaker device to return to the original position.
- ◇ The third step: depress the Jaw Clamp Pedal, open the 4 clamps; release the Jaw Clamp Pedal, the Jaw Clamps returns to the original position.

# Operation declaration

## 4.1 Operating notes

- ◇ Check the connection of air pipe is in place, ensure that no air leakage, ensure the operation space to meet the requirements, then start work.
- ◇ Before any operation, the gas in the tire is needed to be released , and the balance block of the tire balancing device is removed.

## 4.2 Disassemble operation process

### 4.2.1 Bead Loosening

- ◇ Deflate tire completely by removing the valve core from the valve stem. To avoid damaging the clamps and/or wheel, move the clamps to their full inward position before positioning a tire for bead loosening.
- ◇ Pull the bead breaker blade away from the machine and roll the wheel into position. If servicing a performance wheel or any other wheel with Tire Pressure Sensor ), make sure that the valve stem is either in the 12 o'clock or 6 o'clock position.
- ◇ Position the bead breaker blade against the tire next to, but not on, the rim or the sidewall of the tire. Press the breaker pedal to actuate the blade and loosen the bead. It may be necessary to loosen the bead in multiple locations around the tire. Use extra care in positioning the bead breaker blade on larger wheels/tires, and on alloy wheels.



- ◇ Turn wheel around and repeat procedure on the other side of the wheel. This should be the long side of the drop center. It will be easier to clamp the wheel to the table top if the lower bead is loosened last.
- ◇ Determine the mounting side of the wheel. The mounting side is the narrow side of the drop center.

## 4.2.2 Wheel Clamping

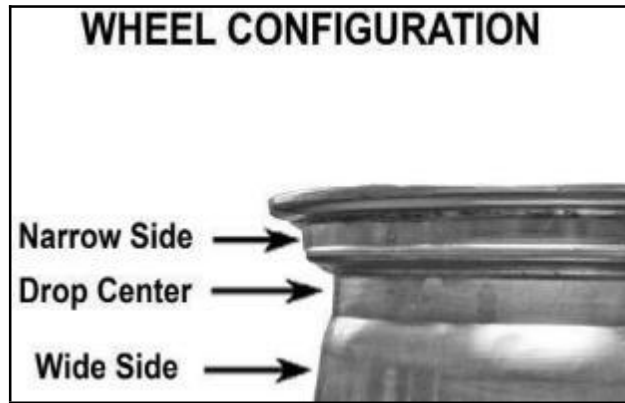

- ◇ Place tire/wheel assembly on Table Top with mounting side up.
- ◇ Use the Wheel Clamp Foot Pedal to move the Clamps inward (pedal down) or outward (pedal up).



## 4.2.3 Tire mounting

- ◇ Apply tire manufacturer's approved rubber lubricant liberally to entire circumference of both upper and lower beads after loosening bead and placing on table top.



- ◇ After the wheel is secured to the Turntable, set the vertical shaft in the working position.
- ◇ Push the Vertical Shaft down and position the Mount/ Demount Head into contact with the rim edge.

- ◇ Press the button on the locking handle to lock. As the slide is locked, the Mount/ Demount Head will move upward approximately 1/8 inch and backward 1/8 inch from the rim edge. The Mount/Demount head roller should not be in contact with the rim edge.



**NOTE:**

**THIS CLEARANCE WILL BE MAINTAINED AS LONG AS THE VERTICAL SHAFT REMAINS LOCKED. THE OPERATOR MAY SWING THE ARM OUT OF THE WAY AND BACK INTO PLACE AGAIN WITHOUT NEEDING TO REPOSITION THE HEAD WHEN CHANGING A LIKE SET OF WHEELS. THE TOOL CLEARANCE MAY CHANGE WITH MACHINE USE AND SHOULD BE INSPECTED OFTEN. FAILURE TO MAINTAIN PROPER CLEARANCE MAY RESULT IN DAMAGE TO THE WHEEL RIM OR TIRE.**

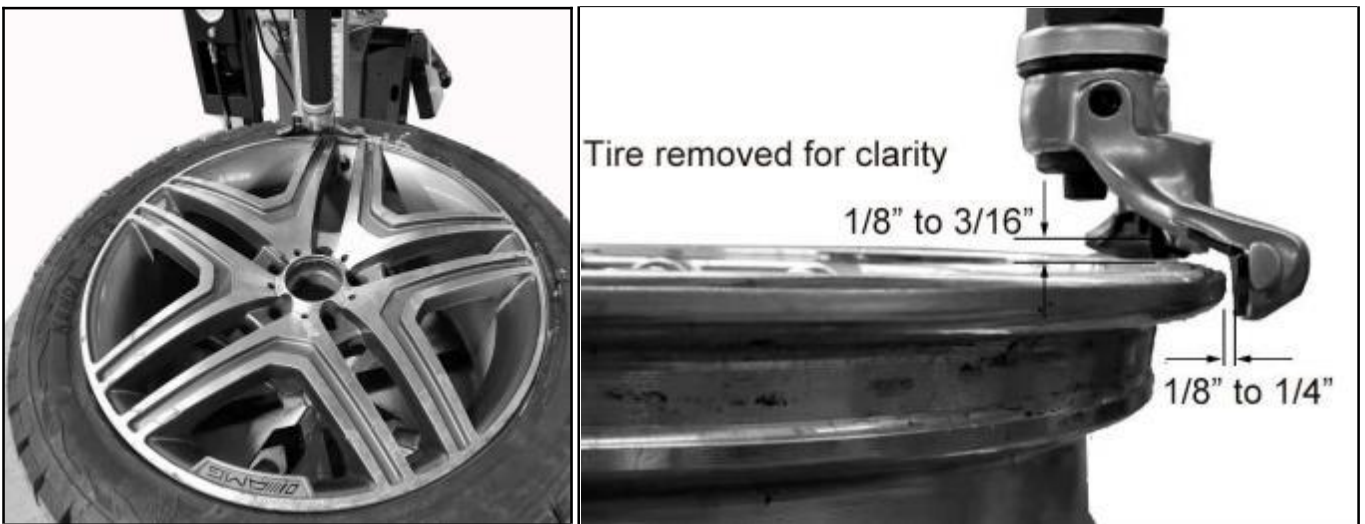

- ◇ Lift the bead onto the mount/demount head with the bead lifting tool, and step on the turntable control pedal to turn the turntable clockwise till the upper bead is completely separated.





THE BEAD LIFTING TOOL AND DEMOUNT HEAD MAY ENCOUNTER RESISTANCE OR COME UNDER LOAD AT TIMES DURING THE MOUNT AND DEMOUNT PROCEDURES. KEEP ONE HAND FIRMLY ON THE TOOL TO AVOID POSSIBLE TOOL KICK BACK. USE THE REVERSING FEATURE (LIFT TABLE TOP PEDAL UPWARDS) TO BACK OUT OF JAM UPS.

### NOTE:

FOR LOW PROFILE TIRES, GET THE UPPER BEAD INTO THE DROP CENTER OF THE WHEEL.

- ◇ Push the Bead Lifting Tool down toward the wheel to lift the tire bead up and over the tab of the demount head. Hold the Bead Lifting Tool in this position. Depress the Table Top Foot Pedal to rotate the wheel clockwise.



- ◇ Hold the Bead Lifting Tool down until the upper bead is solidly above the rim. Continue rotating the wheel clockwise until the upper bead is completely demount.
- ◇ Liberally lubricate the lower bead again, if there was any difficulty lubricating the lower bead earlier.
- ◇ Insert the smooth curved end of the Bead Lifting Tool over the tab end of Mount / Demount Head and below the lower bead of the tire. Push the Bead Lifting Tool down toward the wheel to lift the tire bead up and over the left tab side knob portion of the Mount/ Demount Head. Hold the Bead Lifting Tool in this position.



- ◇ Depress the Table Top Pedal to rotate the wheel
- ◇ The Mount / Demount Head will guide the bead up and over the edge of the wheel. Continue rotation until the lower bead is demount.

## CUSTOM AND SPECIAL WHEELS

IF A CUSTOM WHEEL IS DAMAGED WHILE DEMOUNTING, STOP, AND AVOID DAMAGING THE OTHER WHEELS. CONTINUE ONLY WHEN THE CAUSE IS IDENTIFIED AND CORRECTED.

### ALLOY WHEELS

Some manufacturers offer wheels with little or no drop center. These are not DOT approved. The tire or wheel - or both - can be damaged and the tire could explode under pressure, resulting in serious injury or death. If you attempt to mount/demount this type of wheel, use extreme caution.

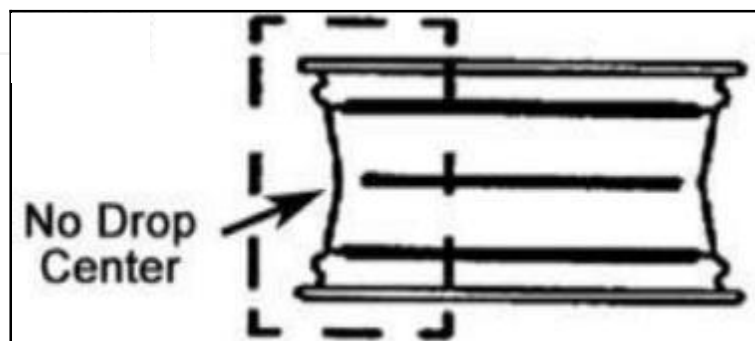

### EUROPEAN PERFORMANCE WHEELS (ASYMMETRICAL HUMP)

Some European wheels have very large humps except near the valve hole. On these wheels, the beads should be loosened at the valve hole on both the upper and lower sides first.

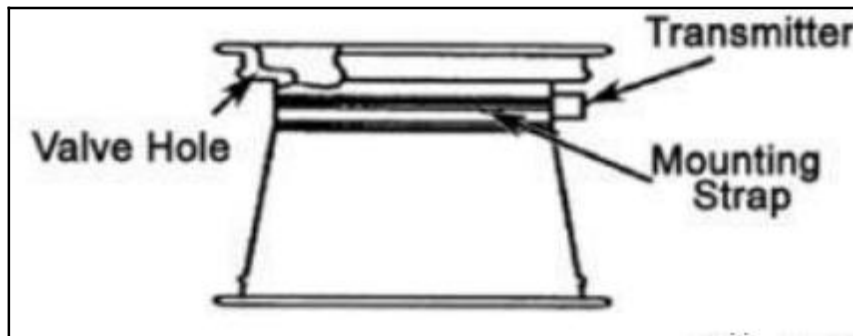

## WHEELS WITH TIRE PRESSURE WARNING SENSORS

After both tire beads are loosened, try to remove the tube. If you can not remove the tube lubricate the beads and rim liberally.

### 4.2.4 Demount Tube type tires

- ◇ After both tire beads are loosened, try to remove the tube. If you can not remove the tube lubricate the beads and rim liberally.
- ◇ Position the demount head and bead lifting tool as described earlier paying careful attention not to pinch the tube. Depress the table top pedal and rotate only a short distance at a time. This allows you to stop the process should you suspect the tube is getting pinched.
- ◇ After upper bead is demount, remove tube and demount lower bead.

#### REMEMBER:

TABLE TOP ROTATION CAN BE STOPPED AT ANY TIME BY REMOVING YOUR FOOT FROM THE ROTATION PEDAL. NORMAL TABLE TOP ROTATION FOR DEMOUNTING IS CLOCKWISE. DEPRESS THE TABLE TOP PEDAL TO ROTATE THIS DIRECTION. TO ROTATE THE TABLE TOP COUNTERCLOCKWISE, LIFT THE PEDAL UP WITH YOUR TOE.

### 4.2.5 Mounting

- ◇ Inspect the wheel closely for damage. Clean the wheel and remove any light corrosion or rubber residue. Do not attempt to service heavily corroded wheels.
- ◇ Inspect tire for damage, paying close attention to the beads. Verify size match between tire and wheel.
- ◇ Lubricate both tire beads liberally with tire manufacturer's approved lubricant.

 **WARNING**

THE RIM AND BEAD MUST BE LIBERALLY LUBRICATED. FAILURE TO USE AN ADEQUATE LUBRICANT CAN LEAD TO THE BEAD BINDING ON THE RIM AND LEAD TO DAMAGE TO THE MOTOR AND OR VOID THE WARRANTY.

THE INFORMATION IN THIS SECTION MUST BE READ AND FOLLOWED CAREFULLY TO PREVENT ACCIDENTS AND INJURIES DURING MOUNTING.

 **WARNING**

CHECK TIRE AND WHEEL CAREFULLY BEFORE MOUNTING. MAKE SURE THE TIRE BEAD DIAMETER AND WHEEL DIAMETER MATCH EXACTLY. CONSULT THE RUBBER MANUFACTURER'S ASSOCIATION FOR APPROVED RIM WIDTHS FOR TIRE SIZES.

 **WARNING**

NEVER MOUNT A TIRE AND WHEEL HANDED TO YOU BY ANYONE WITHOUT CHECKING BOTH TIRE AND WHEEL FOR DAMAGE AND COMPATIBILITY. BE EXTRA CAUTIOUS OF PERSONS WITHOUT KNOWLEDGE OF TIRE SERVICE. KEEP BYSTANDERS OUT OF SERVICE AREA.

 **WARNING**

ATTEMPTS TO FORCE A BEAD SEAT ON MISMATCHED TIRES AND WHEELS CAN CAUSE THE TIRE TO VIOLENTLY EXPLODE, LEADING TO SERIOUS PERSONAL INJURY OR DEATH TO OPERATOR AND/OR BYSTANDERS.

AND MARK IT AS DAMAGED. DO NOT MOUNT A DAMAGED TIRE.

- ◇ Place tire over wheel and move Vertical Arm and Mount/ Demount Head into position as described earlier. Position tire so that the lower bead is above the “duckbill” side of the mount/demount head and below the right front knob. Manually push the tire down into the drop center of the wheel directly across from the Mount/ Demount Head to reduce the tension force on the bead. Depress the Table Top Pedal and rotate the wheel to begin mounting the lower bead. Rotate the Table Top until the lower bead is fully mounted as shown in Fig 11.



**NOTE:  
LOW PROFILE TIRES MAY REQUIRE USE OF THE BEAD LIFTING TOOL.**

**NOTE:  
THE FOLLOWING PROCEDURES SHOW THE ASSIST TOWER BEING USED; THE  
TIRE CHANGER YOU ARE USING MAY NOT HAVE THE ASSIST TOWER**

- ◇ For the top bead, rotate the table top until the valve stem is directly across from the mount head. Lift the upper bead above the left “dull bill” side of the mount/demount head and below the right front knob. With the right side helper, press down on the tire near the right side assist roller to hold the tire in the drop center. Depress the Table Top Pedal. As the Turntable rotates the Lower Arm will follow the tire around. Keep rotating the table until the bead is mounted as shown in Fig. 12.



Fig. 11



Fig. 12



**DO NOT FORCE THE TIRE ONTO THE RIM. BEAD DAMAGE COULD RESULT MAKING THE TIRE UNSAFE AND/OR CREATING THE RISK OF INJURY.**

#### **4.2.6 MOUNTING TUBE TYPE TIRES**

- ◇ Lubricate the beads and rim liberally.
- ◇ Position the Mount/Demount Head as described earlier. Mount the bottom bead first.
- ◇ Apply rubber lubricant to the tube. Insert the tube into the tire, paying careful attention not to pinch the tube. Round out the tube with a small amount of air.
- ◇ Lower the Arm Rollers onto the tire as described earlier.
- ◇ Round out the tube with a small amount of air. Apply rubber lubricant to the tube.
- ◇ Depress the Table Top Pedal and rotate only a short distance at a time.
- ◇ Mount the top bead.

# Inflation

Review the following descriptions and diagrams carefully. Refer to them as necessary during wheel restraint, bead sealing, bead seating, and inflation to verify that you are proceeding properly and safely.



**CHECK INFLATION GAUGE FOR PROPER OPERATION. ACCURATE PRESSURE READINGS ARE IMPORTANT TO SAFE TIRE INFLATION. REFER TO THE OPERATING MAINTENANCE SECTION OF THIS MANUAL FOR INSTRUCTIONS. IF THE RIM HAS BEEN CLAMPED FROM THE OUTSIDE FOR TIRE MOUNTING, RELEASE THE CLAMPS ONCE BEAD SEAL IS OBTAINED, LIFT THE TIRE, AND MOVE THE CLAMPS TO THE CENTER OF THE TABLE TOP.**

**THE CLIP-ON AIR CHUCK ON THE END OF THE INFLATION HOSE AND ALL INFLATION RELATED COMPONENTS SHOULD BE CHECKED WEEKLY FOR PROPER OPERATION. DO NOT USE THIS MACHINE FOR TIRE INFLATION IF ANY PARTS ARE DAMAGED OR APPEAR NOT IN PROPER WORKING ORDER.**



**TIRE FAILURE UNDER PRESSURE IS HAZARDOUS. THIS TIRE CHANGER IS NOT INTENDED TO BE A SAFETY DEVICE TO CONTAIN EXPLODING TIRES, TUBES, WHEELS, OR BEAD SEALING EQUIPMENT. INSPECT TIRE AND WHEEL CAREFULLY FOR MATCH, WEAR, OR DEFECTS BEFORE MOUNTING. ALWAYS USE APPROVED TIRE BEAD LUBRICANT DURING MOUNTING AND INFLATION.**

- ◇ Position One - Tire Pressure - With the Inflation Hose attached to the tire valve and the pedal in this position, the air gauge will register the air pressure in the tire. Whenever your foot is removed from the pedal, it will return to this position



- ◇ Tire Inflation - With the Inflation Hose attached to the tire valve and the pedal depressed, line pressure is allowed to flow through the valve and into the tire for inflation. Tire pressure is not indicated on the gauge in this position

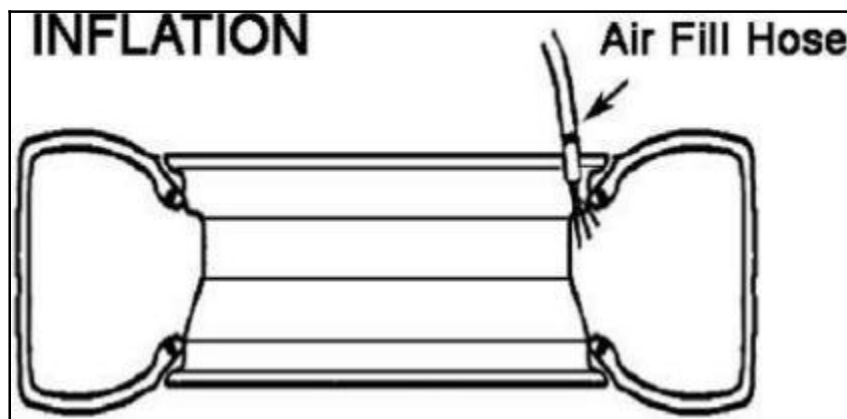

**CHECK THE FUNCTION OF THE PRESSURE LIMITER REGULARLY. MAINTAIN IT ACCORDING TO THE INSTRUCTIONS PROVIDED IN THIS MANUAL FOR SAFE AND PROPER OPERATION. DO NOT TAMPER WITH OR ATTEMPT TO ADJUST THE PRESSURE LIMITER. TIRES REQUIRING INFLATION BEYOND 60 PSI SHOULD ONLY BE INFLATED IN A SAFETY CAGE.**

- ◇ The unit is equipped with a Pressure Limiter/Regulator to assist the operator with proper tire inflation. The Pressure Limiter will keep most car and light truck tires from inflating beyond 60 PSI. It is the operators responsibility to follow all instructions and to control inflation pressure as specified in these instructions.



## 5.1 Stage of Inflation



**THIS MACHINE IS NOT INTENDED TO BE A RESTRAINING DEVICE FOR EXPLODING TIRES, TUBES, OR RIMS. KEEP HANDS AND BODY CLEAR AT ALL TIMES AND AS FAR BACK AS POSSIBLE DURING INFLATION. DO NOT LEAN OVER THE TIRE WHILE INFLATING. AN EXPLODING TIRE, RIM OR OTHER WHEEL COMPONENT CAN CAUSE DEATH TO OPERATOR AND/OR BYSTANDER. REMAIN CLEAR AT ALL TIMES.**

**THIS OBJECT IS A RESTRAINT DEVICE ONLY. IT WILL NOT PROTECT OPERATORS IN THE EVENT OF CATASTROPHIC TIRE/WHEEL RUPTURE OR FAILURE. ALWAYS USE EXTREME CAUTION DURING THE INFLATION PROCEDURE. AS AN ADDED SAFETY PRECAUTION, SAFETY CAGES THAT CONFORM TO OSHA STANDARD 1910.177 ARE RECOMMENDED.**

## 5.2 Bead Sealing

- ◇ Position valve stem in front of operator and connect the inflation hose after removing the valve core
- ◇ Step on the inflation pedal to allow air to flow into the tire and seal the beads.



Bead seating usually occurs on the long tapered side of the wheel first and the shorter side last. Bead seating will usually require at least 7 PSI in the tire. 40 PSI is the maximum safe pressure at this stage regardless of tire operating pressure. Most European import cars and many aftermarket alloy wheels are very tight and can be difficult to bead seat. Also note that asymmetrical hump and run-flat tires are extremely difficult to bead seat. Follow tire manufacturer's recommended procedure for bead seating.



**OPERATOR SHOULD KEEP HANDS, ARMS, AND ENTIRE BODY AWAY FROM THE TIRE DURING THE FOLLOWING BEAD SEAT AND INFLATION PROCEDURES. DO NOT STAND OVER TIRE, AS PERSONAL INJURY COULD RESULT FROM INFLATING TIRE.**

- ◇ Once tire pressure is indicated on the air gauge (inflation pedal depressed, continue to inject air into the tire in short intervals. Check the pressure frequently. Stand back during bead seat. Keep hands, arms, and entire body away from tire during this procedure. Tire beads should move outward and “pop” into their bead seat position as pressure inside the tire increases. If this does not happen, a problem exists. Investigate carefully.
- ◇ Release air pressure from the tire by pressing the manual Pressure Relief Valve.



**CHECK TIRE PRESSURE FREQUENTLY. NEVER EXCEED 40 PSI WHILE SEATING BEADS. ONCE SEATED, NEVER EXCEED TIRE MANUFACTURER'S RECOMMENDED AIR PRESSURE. TIRES CAN EXPLODE, ESPECIALLY IF THEY ARE INFLATED BEYOND THEIR LIMITS. AT ALL PRESSURE LEVELS WHEN INFLATING THROUGH THE VALVE STEM, KEEP HANDS, ARMS, AND ENTIRE BODY AWAY FROM INFLATING TIRE. AN EXPLODING TIRE, WHEEL, OR BEAD SEALING EQUIPMENT MAY PROPEL UPWARD AND OUTWARD WITH SUFFICIENT FORCE TO CAUSE SERIOUS INJURY OR DEATH TO OPERATOR OR BYSTANDER.**



**NEVER ATTEMPT TO MOUNT AND INFLATE MISMATCHED TIRES AND WHEELS. MISMATCHED TIRE AND WHEEL COMBINATIONS CAN EXPLODE, CAUSING PERSONAL INJURY OR DEATH TO OPERATOR AND BYSTANDERS. FOR SAFETY, DO NOT ATTEMPT TO MOUNT AND INFLATE MISMATCHED TIRES AND WHEELS.**



**IF OPERATOR IS UNABLE TO OBTAIN BEAD SEAT, SOMETHING IS WRONG. DEFLATE TIRE COMPLETELY, INSPECT TIRE AND WHEEL, CORRECT ANY PROBLEMS FOUND, RE-LUBRICATE BOTH TIRE BEADS, AND REATTEMPT BEAD SEAL AND SEAT PROCEDURES. FOLLOW ALL SAFETY INSTRUCTIONS IN THIS MANUAL AND ON MACHINE**

### **5.3 Tire Inflation**

- ◇ Make sure both beads are seated. When both beads are seated, the tire is ready for inflation.
- ◇ Replace the valve core if it was removed.
- ◇ Depress the Inflation Pedal to inflate the tire. **DO NOT STAND OVER TIRE DURING INFLATION.**
- ◇ Do not inflate the tire in excess of the manufacturer's prescribed pressure as stamped on the tire sidewall. The typical inflation pressure for automobile tires is between 24 and 45 PSI. Light truck inflation pressure typically covers a wider range. Release air pressure from the tire by pressing the manual Pressure Relief Valve

**CHECK TIRE PRESSURE FREQUENTLY. NEVER EXCEED 40 PSI WHILE SEATING BEADS. ONCE SEATED, NEVER EXCEED TIRE MANUFACTURER'S RECOMMENDED AIR PRESSURE. TIRES CAN EXPLODE, ESPECIALLY IF THEY ARE INFLATED BEYOND THEIR LIMITS. AT ALL PRESSURE LEVELS WHEN INFLATING THROUGH THE VALVE STEM, KEEP HANDS, ARMS, AND ENTIRE BODY AWAY FROM INFLATING TIRE. AN EXPLODING TIRE, WHEEL, OR BEAD SEALING EQUIPMENT MAY PROPEL UPWARD AND OUTWARD WITH SUFFICIENT FORCE TO CAUSE SERIOUS INJURY OR DEATH TO OPERATOR OR BYSTANDER.**

**Safety Cage**



**NOTE:**

**WHEN INFLATING TIRES THAT REQUIRE MORE THAN 60 PSI, ALWAYS USE A SAFETY CAGE AND AIR HOSE WITH A CLIP-ON AIR CHUCK AND IN-LINE VALVE. THE HOSE MUST HAVE ENOUGH LENGTH BETWEEN THE CHUCK AND THE OPERATION/IN-LINE VALVE TO ALLOW THE TECHNICIAN TO STAND OUTSIDE THE TRAJECTORY**

**BEFORE MAKING ANY INSPECTION**

**ADJUSTMENT, OR REPAIR, DISCONNECT THE POWER SOURCE AND OR AIR SUPPLY AND BLOCK OUT ALL MOVING PARTS TO PREVENT INJURY. KEEP THE MACHINE AND THE IMMEDIATE WORK AREA CLEAN. DO NOT USE COMPRESSED AIR TO REMOVE DIRT AND DEBRIS FROM THE MACHINE. FOREIGN MATERIAL MAY BE PROPELLED INTO THE AIR AND INTO OPERATOR OR BYSTANDER CAUSING PERSONAL INJURY.**

**WEAR PROTECTIVE CLOTHING AND USE EYE PROTECTION WHEN MAKING ANY ADJUSTMENTS OR REPAIRS TO THE MACHINE.**

## **6 Maintenance**

### **6.1.1 Maintenance**

- ◇ Prohibit unauthorized personnel for maintenance operation. To extend the service life of the tire changer, maintenance should be performed according to the requirements of the manual. If the machine is not maintained regularly, the operation and reliability can not be guaranteed, and even cause danger to the operator or the people in the vicinity of the machine. Before any maintenance operation, circuit and gas supply device must be disconnected , turn off the switch. In order to release the pressure of

the air from the line, it is necessary to press the pedal 3-4 times.

- ◇ It must be professional staff using the original spare parts do the timely replacement of damaged parts. The safety device (safety valve, control valve) of the unauthorized removal or replacement is a violation of state regulations on work safety. (Note: the manufacturer is not responsible for damage caused by the parts of other manufacturer and the damage caused by the disassembling of the safety device).

### 6.1.2 Tending

- ◇ Regular use of diesel oil to clean the turntable, to prevent the formation of dirt. Daub lubricating oil in the skid-way of the clamps.
- ◇ As shown in figure 15-a, control oil mist level that in the oil mist device, if the oil level is lower, you need to unscrew the oil F, and then as figure 15-a., control oil mist level, HG ISO and viscosity of VG32 ISO type oil mist is recommended.(like : ESSO Fe-bis K32 , MOBIL Valvoline 1405 , KLUBER32). when stepping the pedal 3 to 4 times, check whether there is oil drops into the oil cup F, if not, adjust screw D.
- ◇ As shown in figure 15-b, 20 days after the first use of the machine, re-tighten the screw A and B that is in the clamps.
- ◇ As shown in figure 15-c, machine horsepower is not enough, check the triangle belt of the motor by the following steps: (before any operation, to cut off the power) first, Unscrew the 4 screws on the side of the box, remove the left side protective plate of the tire changer, second, use special adjustment screw X (Figure 15-c) that is in the motor support base to adjust the triangle belt.
- ◇ As shown in figure 15-d, If the (I) lock is not good or can not be stopped at the top of the 2mm, it is necessary to adjust the nut on the operating arm.
- ◇ As shown in figure 15-e, when cleaning or replacing silencer which controls the opening or closure of the clamps(G), follow the following steps: first, unscrew the 4 screws on the side of the box, remove the left side protective plate on the tire changer. Second, in the pedal (V1, V2) system which controls the opening or closure of the clamps(G), unscrew silencer. Clean with compressed air nozzle, if damaged, replace with the same parts.

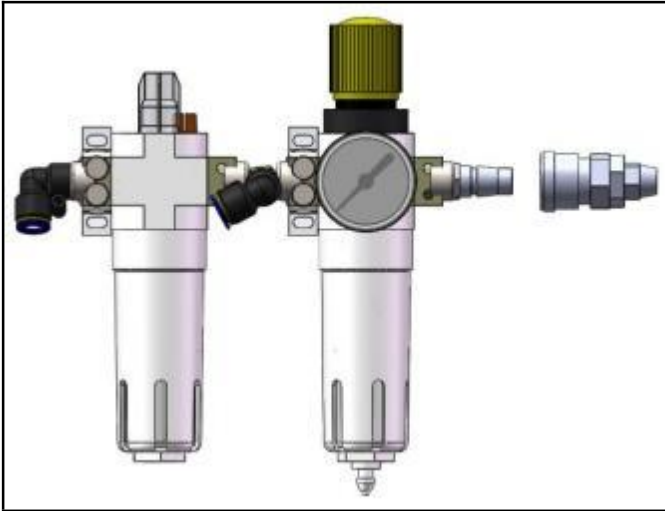

Figure 15-a

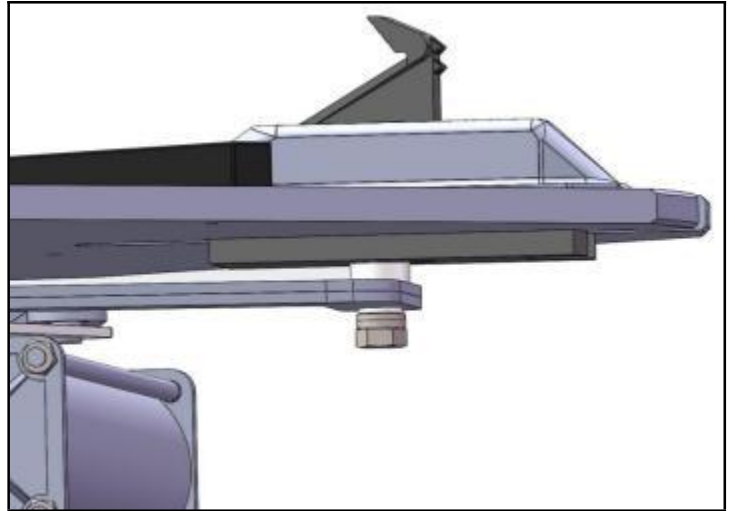

Figure 15-b

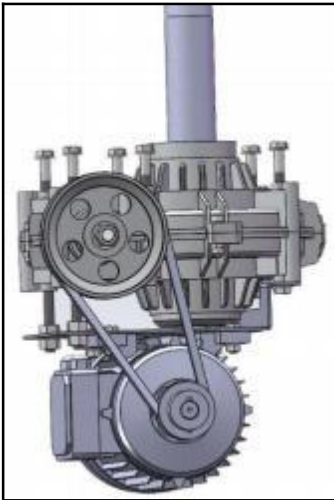

Figure 15-c

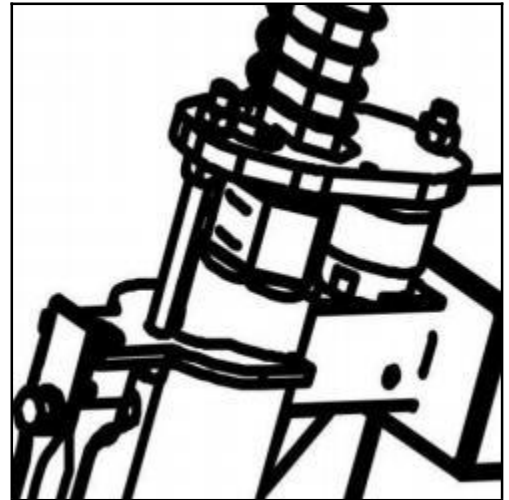

Figure 15-d

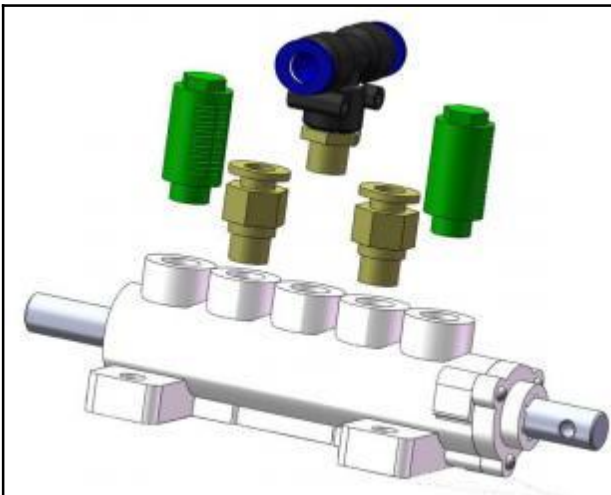

Figure 15-e

## **6.2 Storage and scrap**

### **6.2.1 Storage**

- ◇ If you want a long time storage of machine, please disconnect all the energy supply, and lubricate the skid-way of the clamps on the turntable to prevent oxidation.

### **6.2.2 Scrap**

- ◇ In accordance with the law of the metal and nonmetal for scrap processing. In the specified place release the oil inside the machine.

# Fault causes and Solutions

Note: if you can not solve the failure, please contact the manufacturer to provide help. We will be the first time to help you to solve the failure. Provide the relevant fault information and fault pictures, thus the manufacturer can get rid of the trouble at the fastest speed.

Failure phenomenon	Failure cause	Resoluteness
Unidirectional rotation of the turntable	Universal steering switch damage	Replace universal steering switch
Rotary table does not rotate	Triangle damage	Replace triangle belt
	Universal steering switch damage	Replace universal steering switch
	Motor fault or line fault	Check motor and external plug or socket
Rotary clamp opening / closing speed is slow	Muffler blockage	Clean or replace muffler
The turntable can't lock the rim correctly	Clamps have trouble	Replace clamps
	Rotary cylinder has trouble	Replace cylinder or repair cylinder sealing ring
Working head can touch the rim	Lock plate adjustment is not correct or faulty	Adjust or replace the locking plate (Figure 18/d)
	Working head screw loose	Tighten screws (Figure 12/a)
The pedal is not located at work position.	Return spring has trouble	Replace return spring
Operating difficulties of the tire device	Muffler blockage	To clean or replace the silencer (Figure 18/f)
	Cylinder sealing ring damage of pressure device	Replace sealing ring



# Current Switch Diagram

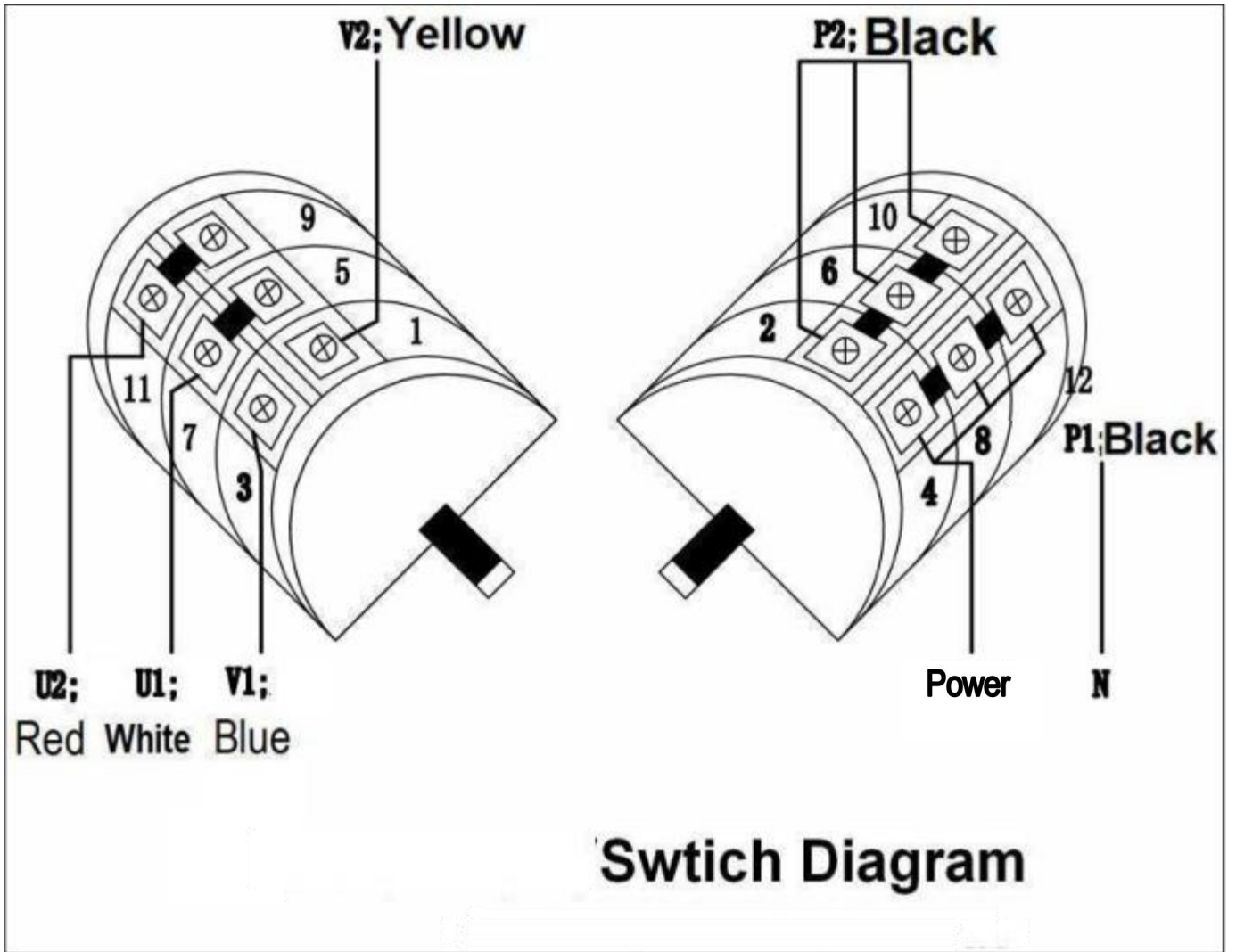

# Explosive Drawing

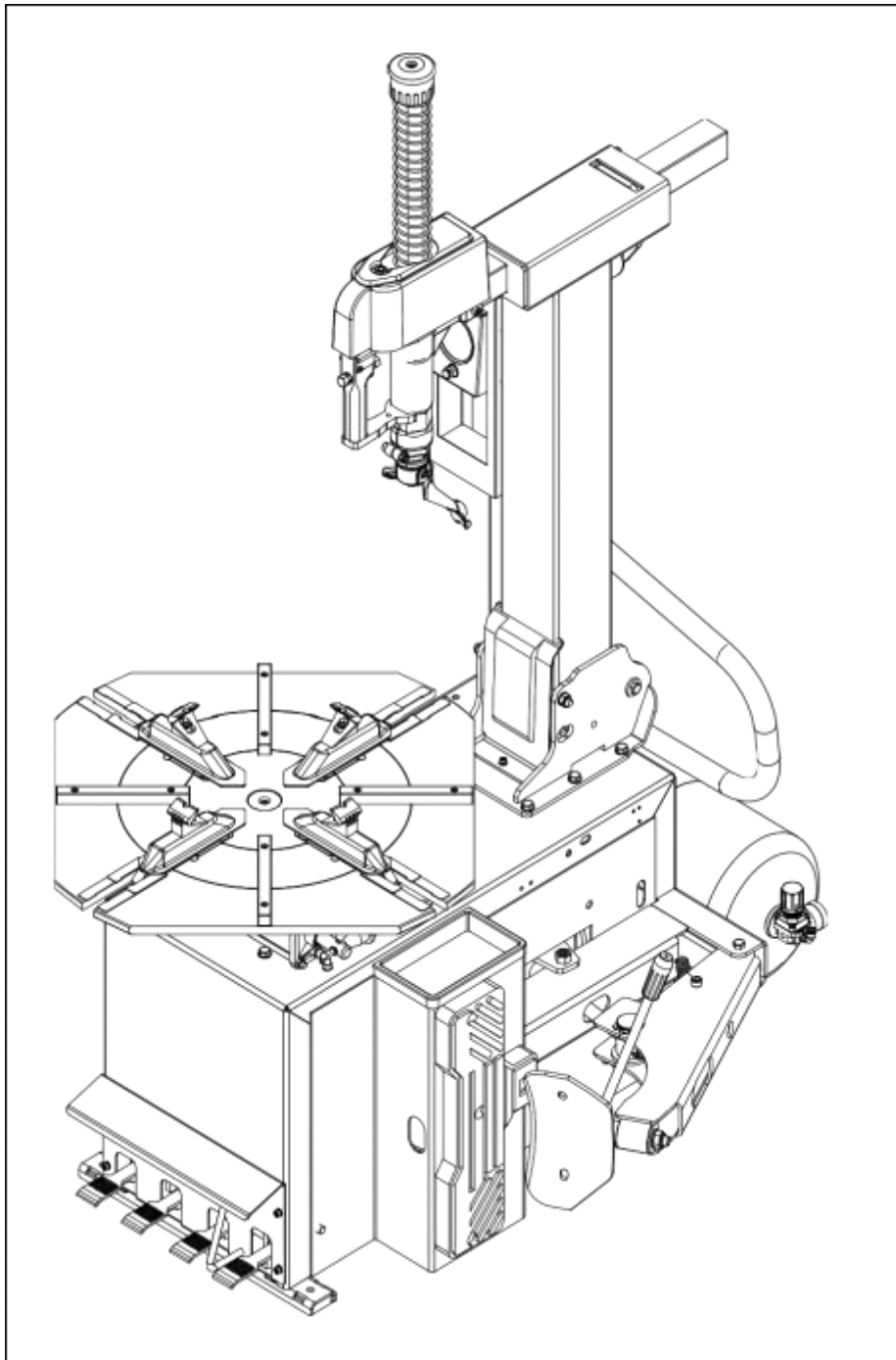

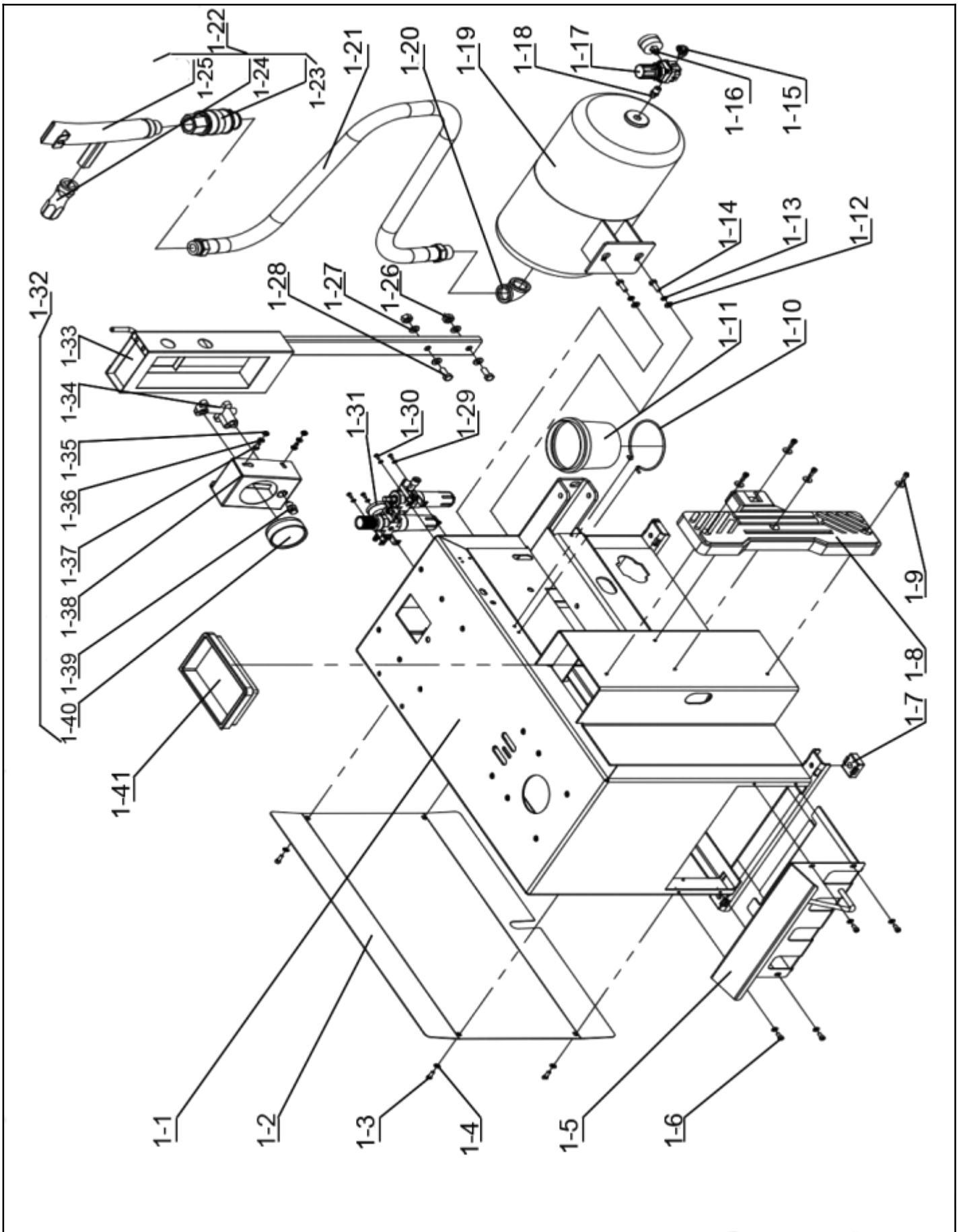

1 Main Body Ass'y			
S/N	PART#	DESCRIPTION	QTY
1-1	5621100	Extended Box Welding	1
1-2	575A116	Side panel	1
1-3	GB/T70. 1	Hexagon stud screw M6X16	8
1-4	GB/T97. 1	Flat washer A 6	8
1-5	5758100	Four-foot fixed baffle handle welding	1
1-6	GB/T70. 1	Hexagon stud screw M6X12	4
1-7	8501012	Foot pad	4
1-8	5621012	T-shaped rubber	1
1-9	GB/T96	Large gasket 6	4
1-10	8501013	Bucket ring	1
1-11	8501014	Water bucket	1
1-12	GB/T93	Spring washer 8	2
1-13	GB/T97. 1	Flat washer A 8	2
1-14	GB/T5783	Hexagon head bolt M8X25	2
1-15		Fast plug right angle terminal φ6-G1/8	1
1-16		Pressure gauges	1
1-17	AR2000-02-0.85MPa	Pressure regulating valve	1
1-18		External buckle variable diameter G1/4-G1/8 wire	1
1-19	5621530	Gas Storage Tank General Welding	1
1-20		Bend 1 inch	1
1-21		Explosive hose B	1
1-22	LN1030-630000	Explosive nozzle assembly	1
1-23		Hand controlled burst valve	1
1-24	LN1030-640001	Handle set	1
1-25	LN1030-630000	Explosive nozzle welding	1
1-26	GB/T6170	Hexagon nut M10	2
1-27	GB/T97. 1	Flat washer A 10	4
1-28	GB/T5783	Hexagon head bolt M10X25	2
1-29	GB/T97. 1	Flat washer A 4	4
1-30	GB/T818	Cross groove head screw M4X10	4
1-31	301100	triple cup A	1
1-32	5629000	Frame assembly	1
1-33	5629000	Welding of table holder	1
1-34		Six-column frame	1
1-35	GB/T6170	Hexagon nut M6	2
1-36	GB/T97. 1	Flat washer A 6	2
1-37	GB/T5783	Hexagon head bolt M6X12	2
1-38	5629001	Table	1
1-39	5902210	Drain valve	1
1-40		Pressure gauges	1
1-41	5621013	Right panel water box	1

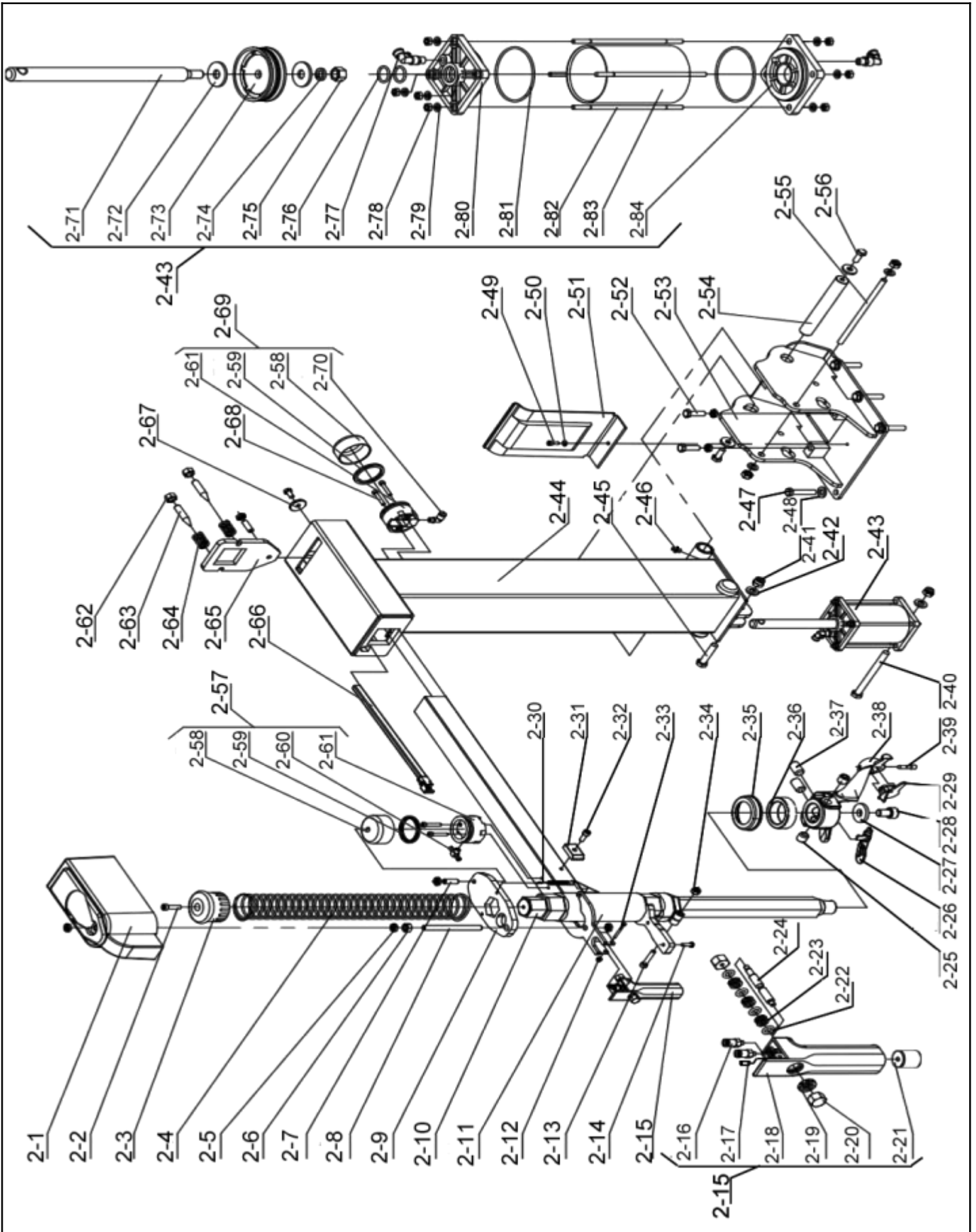

2		Vertical Column Ass'y					
S/N	PART#	DESCRIPTION	QTY	S/N	PART#	DESCRIPTION	QTY
2-1	565	Sliding Arm Cover	1	2-31	575- 120004	Limit Plate	1
2-2	GB/T70. 1	Screw M8X30	1	2-32	GB/T70. 1	Screw M8X20	1
2-3	5622504	Plastic Cover for Shaft	1	2-33	GB/T70. 1	Screw M4X40	1
2-4	5622503	Spring (41MM)	1	2-34	GB/T889. 1	Lock Nut M8	1
2-5	GB/T6172. 1	Thin Bolt M10	8	2-35	5622504	Shock Absorption Rack	1
2-6	GB/T889. 1	Lock Nut M10	3	2-36	5622505	Shock Absorption Ring	1
2-7	GB/T77	Lock Screw M10X30	2	2-37	GB/T77	Lock Nut M12X20	2
2-8	5622308	Adjusting Screw for Lock Plate	1	2-38	5622502	Demount Head	1
2-9	5622309	Lock Plate for Hexagon Shaft	1	2-39	5622505	Screw Shaft	1
2-10	5622501	Hexagon Shaft	1	2-40	GB/T5782	Bolt M12X130	1
2-11	5622300	Sliding Arm Weldment	1	2-41	GB/T889. 1	Lock Nut M12	2
2-12	GB/T889. 1	Lock Nut M4	1	2-42	GB/T97. 1	Flat Washer Class A 12	2
2-13	GB/T70. 1	Screw M8X40	1	2-43	5625100	Vertical Cylinder Ass'y	1
2-14	GB/T5783	Screw M6X20	1	2-44	5622200	Vertical Column Ass'y	1
2-15	1030000	Sliding Arm Control Valve Ass'y	1	2-45	GB/T5783	Bolt M12X55	1
2-16		Quick Fitting Ending M5-φ4	2	2-46	GB/T1152	Oil Cup M8X1	1
2-17	GB/T77	Lock Nut M5X10	1	2-47	GB/T5782	Bolt M10X55	6
2-18	1030001	Control Valve	1	2-48	GB/T97. 1	Flat Washer Class A 10	8
2-19	1030004	Valve Cap	1	2-49	GB/T70. 1	Bolt M6X16	1
2-20	1030003	Control Button	2	2-50	GB/T97. 1	Flat Washer Class A 6	1
2-21	1030008	Control Valve Fixing Pin	1	2-51	LN562-010002	Plastic Cover	1
2-22	1030005	O Sealing Ring d8X2.65	4	2-52	GB/T5783	Bolt M10X35	2
2-23	1030006	Valve Bushing	3	2-53	5622100	Vertical Column Base Weldment	1
2-24	1030002	Valve Rod	1	2-54	5622206	Rotation Shaft	1
2-25	GB/T80	Lock Nut M12X12	2	2-55	GB/T15389	Screw Shaft M10X200	1
2-26	5622506	Demount Head Protector	1	2-56	GB/T5783	Bolt M10X25	2
2-27	8503017	Demount Head Protector	1	2-57	1012000	Lock Valve Ass'y	1
2-28	GB/T70. 1	Bolt M10X16	1	2-58	1010002	Lock Valve Cap	2
2-29	5622504	Demount Head Protector	1	2-59	1010003	YX sealing Ring φ 59.5X50X5	2
2-30	575- 120005	Torsion Spring	1	2-60		Lock Cap Fitting φ4 1/8"	1

2 Vertical Column Ass'y							
S/N	PART#	DESCRIPTION	QTY	S/N	PART#	DESCRIPTION	QTY
2-61	1010001	Lock Valve	2	2-73	5625202	Piston	1
2-62	GB/T6170	Bolt M12	2	2-74	GB/T93	Elastic Washer 12	1
2-63	5622312	Location Screw M12X60	2	2-75	GB/T6170	Bolt M12	1
2-64	5622311	Spring	2	2-76	5625006	O Ring d20X2.65	2
2-65	5622310	Sliding Arm Locking Plate	1	2-77		Fast Fitting Ending $\phi 6$ 1/8"	2
2-66	5752422	Air Hose Guide	1	2-78	GB/T6170	Bolt M8	8
2-67	5622313	Washer	1	2-79	GB/T97. 1	Flat Washer Class A 8	8
2-68	GB/T70. 1	Screw M6X35	4	2-80	5625002	Lock Cap	1
2-69	1011000	Lock Valve Ass'y	1	2-81	5625005	O Sealing Ring D77.5X2.65	2
2-70		Fast Fitting Ending $\phi 4$ 1/8"	1	2-82	5625007	Fixing Rod M8X540	4
2-71	5625201	Piston Rod	1	2-83	5625001	Cylinder Barrel	1
2-72	GB/T96	Big Washer 12	2	2-84	5625003	Cylinder Cap	1

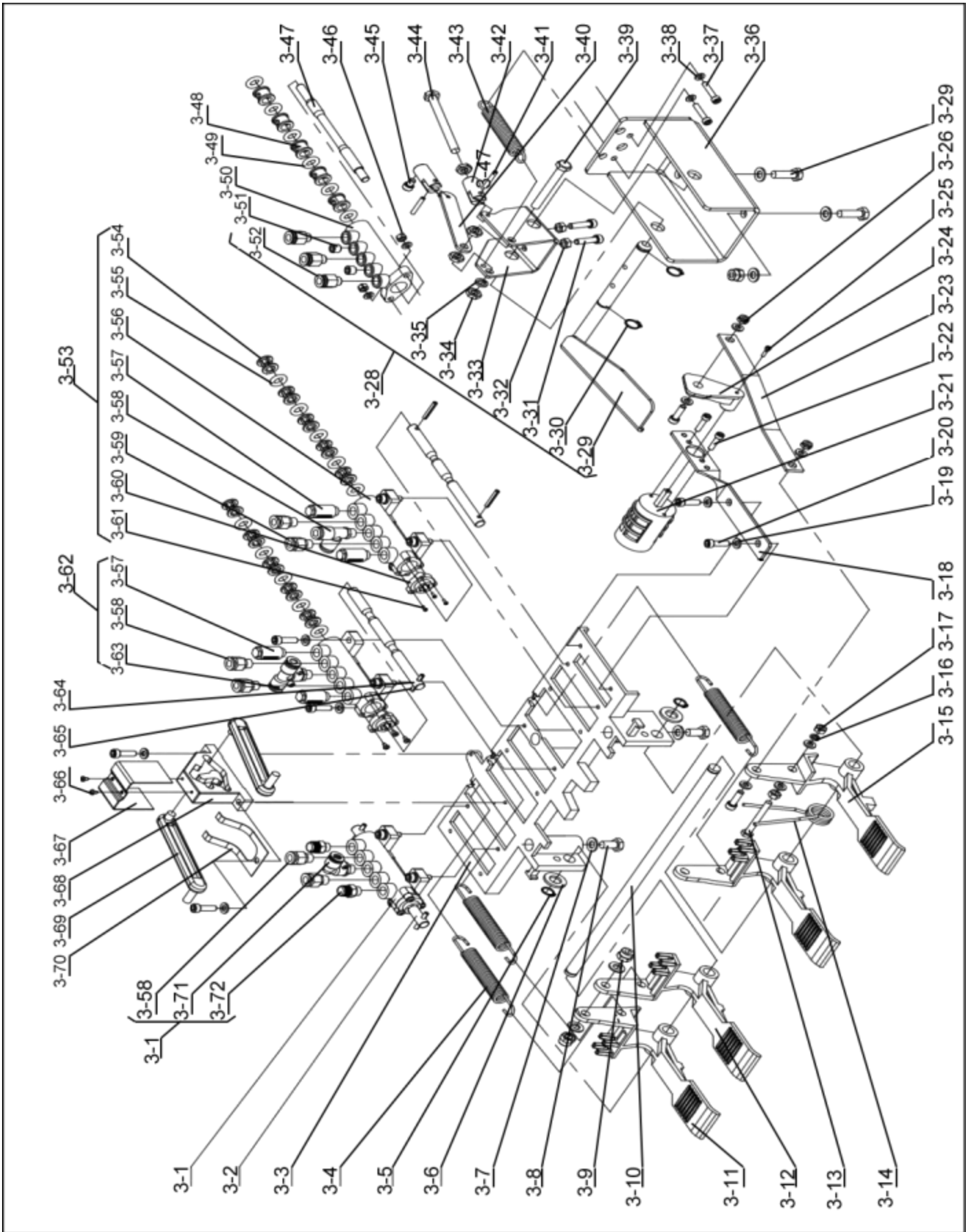



3	Pedal Ass'y						
S/N	PART#	DESCRIPTION	QTY	S/N	PART#	DESCRIPTION	QTY
3-1	5628003C	Inflation Pedal Valve Ass'y		3-31	GB/T70. 1	Bolt M6X25	2
3-2	8808007	Valve Rod	2	3-32	GB/T52	Bolt M6	2
3-3	8808002	Pedal Seat	1	3-33	6209102	Pedal Fork	1
3-4	8808028	Spring	3	3-34	GB/T6172. 1	Thin Bolt M8	4
3-5	GB/T894. 1	Circlip 12	2	3-35	GB/T93	Elastic Washer 8	1
3-6	GB/T97. 1	Flat Washer Class A 12	2	3-36	6209101	Pedal seat	1
3-7	GB/T97. 1	Flat Washer Class A 8	9	3-37	GB/T70. 1	Bolt M5X25	2
3-8	GB/T5783	Bolt M8X16	3	3-38	GB/T97. 1	Flat Washer Class A 5	4
3-9	GB/T889. 1	Screw M8	4	3-39	GB/T5782	Bolt M8X65	1
3-10	8808023	Pedal Shaft	1	3-40	6208004	Connection Plate	1
3-11	8808015	Pedal	1	3-41	GB/T879. 1	Elastic Round Pin 4X25	2
3-12	8808016	Pedal TF	2	3-42	6208005	Threaded Bushing	2
3-13	GB/T5782	Screw M6X50	1	3-43	6209005	Spring	1
3-14	8808023	Torsion Spring	1	3-44	GB/T5782	Bolt M8X90	1
3-15	8808017	Pedal TF-C	1	3-45	GB/T70. 1	Screw M6X8	1
3-16	GB/T93	Elastic Washer 6	1	3-46	GB/T52	Bolt M5	2
3-17	GB/T52	Bolt M6	2	3-47	6209108	Valve Rod	1
3-18	8808018	Switch Support	1	3-48	6209002	Valve Bushing	5
3-19	GB/T97. 1	Flat Washer Class A 6	2 2	3-49	6209003	O Sealing Ring d9.5X4	6
3-20	GB/T70. 1	Bolt M6X20	1 8	3-50	6209001	Valve Body	1
3-21	8808021	Switch 20A	1	3-51	JB1000-77	Block ZG1/8	2
3-22	GB/T70. 1	Bolt M5X20	2	3-52		Fast Fit Endingφ8 1/8"	3
3-23	8808019	Switch Puller	1	3-53	8808003A	Bead Breaker Pedal Valve Ass'y	1
3-24	8808022	Switch Support	1	3-54	8808008	Inner Bushing	15
3-25	GB/T70. 1	Bolt M3X12	1	3-55	8808009	O Sealing Ring d9.7X4	15
3-26	GB/T889. 1	Lock Nut M6	2	3-56	8808003	Valve Body	3
3-27	GB/T5783	Screw M8X25	2	3-57	P1	Silencer	4
3-28	6209000	Inflation Pedal Ass'y	1	3-58	PD-01	Fast Fit Ending φ8 1/8"	1
3-29	6201500	Inflation Pedal Weldment	1	3-59	PC8-01	Fast Fit Ending φ8 1/8"	6
3-30	GB/T894. 1	Circlip 14	2	3-60	8808225	Valve Cap	3

3	Pedal Ass'y						
S/N	PART#	DESCRIPTION	QTY	S/N	PART#	DESCRIPTION	QTY
3-61	GB/T845	Self-tapping Screw ST3 5X13	9	3-67	8808027	Baffle Plate	1
3-62	850803B	Turntable Pedal Valve Ass'y	1	3-68	8808012	Cam	1
3-63	PD8-01	Fast Fit Ending $\phi 8$ 1/8"	1	3-69	8808014	Connection Rod	2
3-64	8808026	Valve Rod	1	3-70	8808013	Spring Plate	1
3-65	GB/T879. 1	Elastic Round Pin 4X25	5	3-71	PC8-01	Fast Fit Ending $\phi 8$ 1/8"	
3-66	GB/T845	Self-tapping Screw ST2.9X6.5	2	3-72	P01	Silencer 1/8"	2

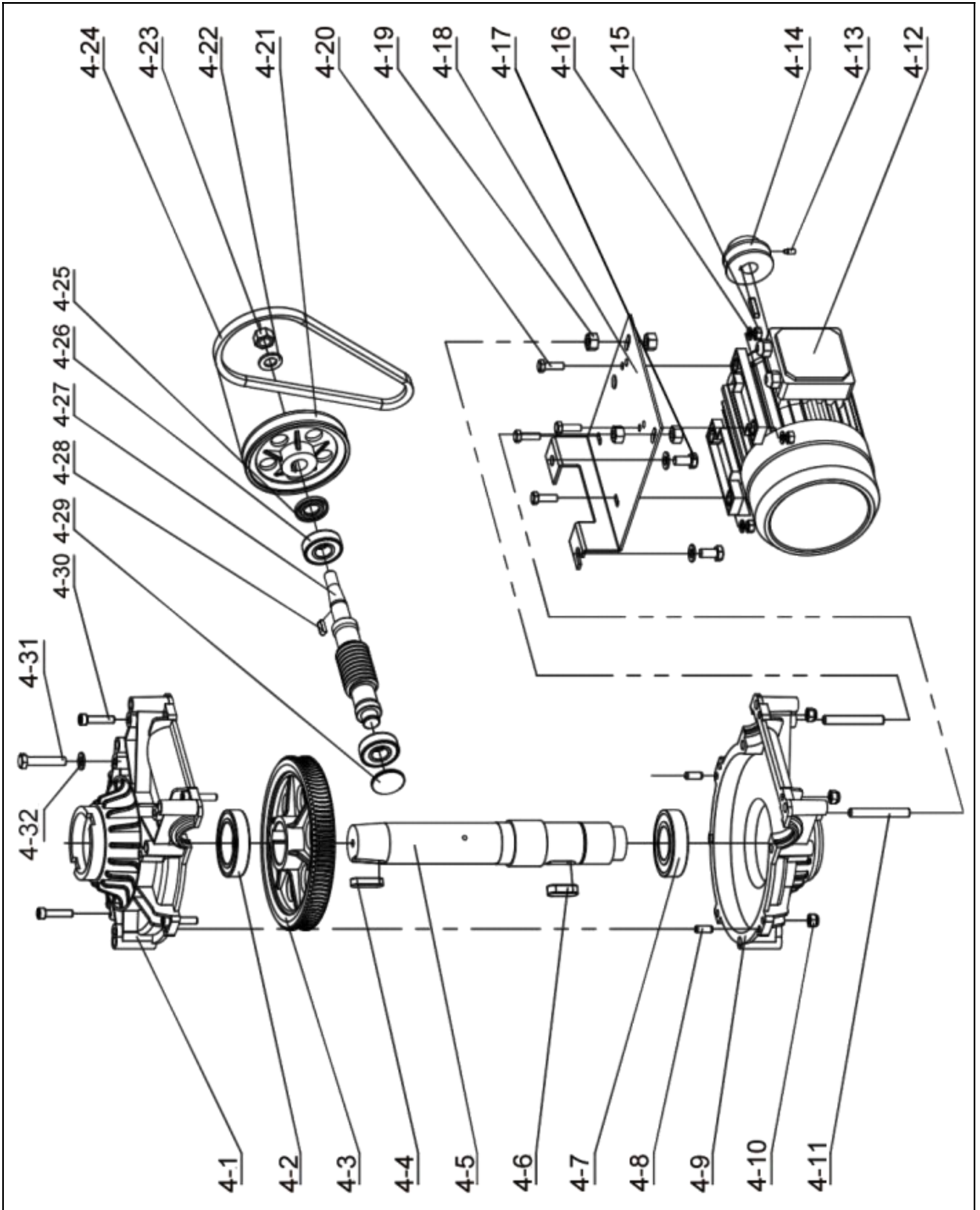

4	Gear Box Ass'y						
S/N	PART#	DESCRIPTION	QTY	S/N	PART#	DESCRIPTION	QTY
4-1	6207001	Gear Box Cover	1	4-17	GB/T5783	Bolt M10X20	2
4-2	GB/T276	Ball Bearing 6010	1	4-18	8807013	565 Motor Plate	1
4-3	6207006	Gear Wheel	1	4-19	GB/T6170	Bolt M10	4
4-4	GB/T1096	Flat Key 12X8X40	1	4-20	GB/T5783	Bolt M8X25	4
4-5	62070003	Vertical Shaft	1	4-21	6207004	Belt Pulley	1
4-6	GB/T1096	Flat Key 14X9X36	1	4-22	GB/T97.1	Flat Washer Class A 14	1
4-7	GB/T276	Ball Bearing 6208	1	4-23	GB/T6170	Bolt M14	1
4-8	GB/T119.1	Round Pin 8X20	2	4-24	GB/T11544	V Belt A635	1
4-9	6207002	Bottom Cover	1	4-25	6207009	Seal	1
4-10	GB/T889.1	Lock Nut M8	7	4-26	GB/T276	Ball Bearing 6205	2
4-11	GB/T77	Lock Screw M10X75	2	4-27	6207007	Gear Rod	1
4-12	8807014	Dual-Speed Motor	1	4-28	GB/T1096	Flat Key 6X6X18	1
4-13	GB/T80	Lock Nut M6X10	1	4-29	6207008	Seal 40X8	1
4-14	6207016	Belt Pulley	1	4-30	GB/T70.1	Screw M8X35	7
4-15	GB/T6170	Bolt M8	4	4-31	GB/T5782	Bolt M10X50	6
4-16	GB/T97.1	Flat Washer Class A 8	4	4-32	GB/T97.1	Flat Washer Class A 10	8

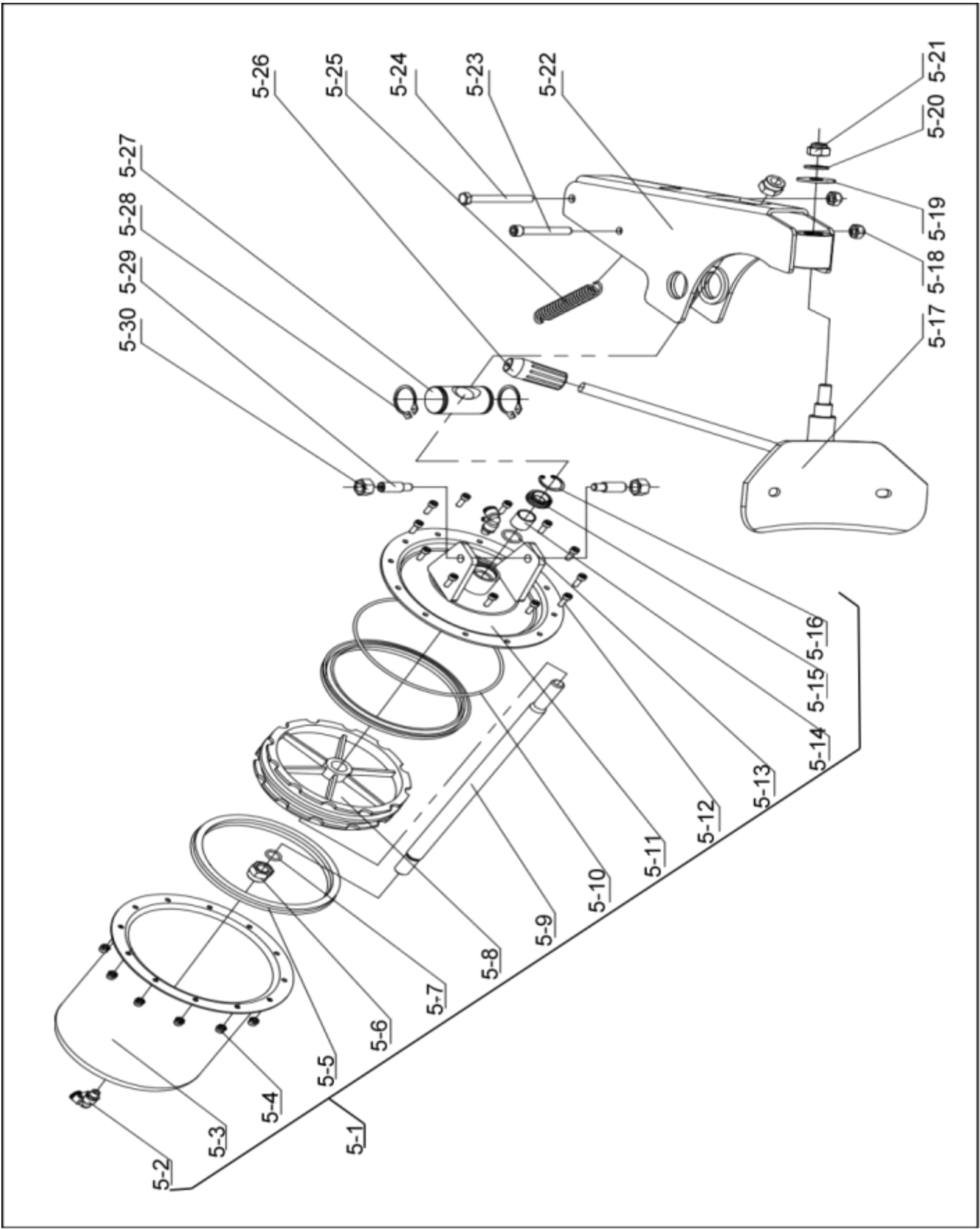

5	Bead Breaker Ass'y						
S/N	PART#	DESCRIPTION	QTY	S/N	PART#	DESCRIPTION	QTY
5-1	6205000	Bead Breaker Cylinder Ass'y	1	5-16	GB/T893.1	Circlip 30	1
5-2	8805025	Fast Fit Connector	2	5-17	5624200	Bead Breaker Weldment	1
5-3	6205001	Bead Breaker Barrel	1	5-18	GB/T889.1	Lock Nut M10	2
5-4	GB/T889.1	Lock Nut M6	12	5-19	GB/T96	Big Washer 14	1
5-5	6205008	Y Ring 186X12X9	2	5-20	GB/T97.1	Flat Washer 14	2
5-6	GB/T889.1	Lock Nut M16	2	5-21	GB/T889.1	Lock Nut M14	1
5-7	6205009	O Sealing Ring d 14X2 65	1	5-22	15624100	Bead Breaker Arm Weldment	1
5-8	6205006	186 Piston	1	5-23	GB/T70.1	Bolt M10X70	1
5-9	8505011	Piston Rod	1	5-24	GB/T5782	Bolt M10X90	1
5-10	6205007	O Seal Circle d 184X3.5	1	5-25	8804106	Bead Breaker Spring	1
5-11	6205300	Cylinder Cap Weldment	1	5-26	8504008	Hand Wheel Protector	1
5-12	GB/T70.1	Screw M6X16	12	5-27	5754003	Horizontal Shaft	1
5-13	6205005	O Sealing Ring d20X2 65	1	5-28	GB/T894.1	Circlip 40	2
5-14	8805011	Oil Free Bearing 2015	1	5-29	8805026	Lock Pin M14X40	2
5-15	8805008	Seal 30X20X7	1	5-30	GB/T6170	Screw M14	2

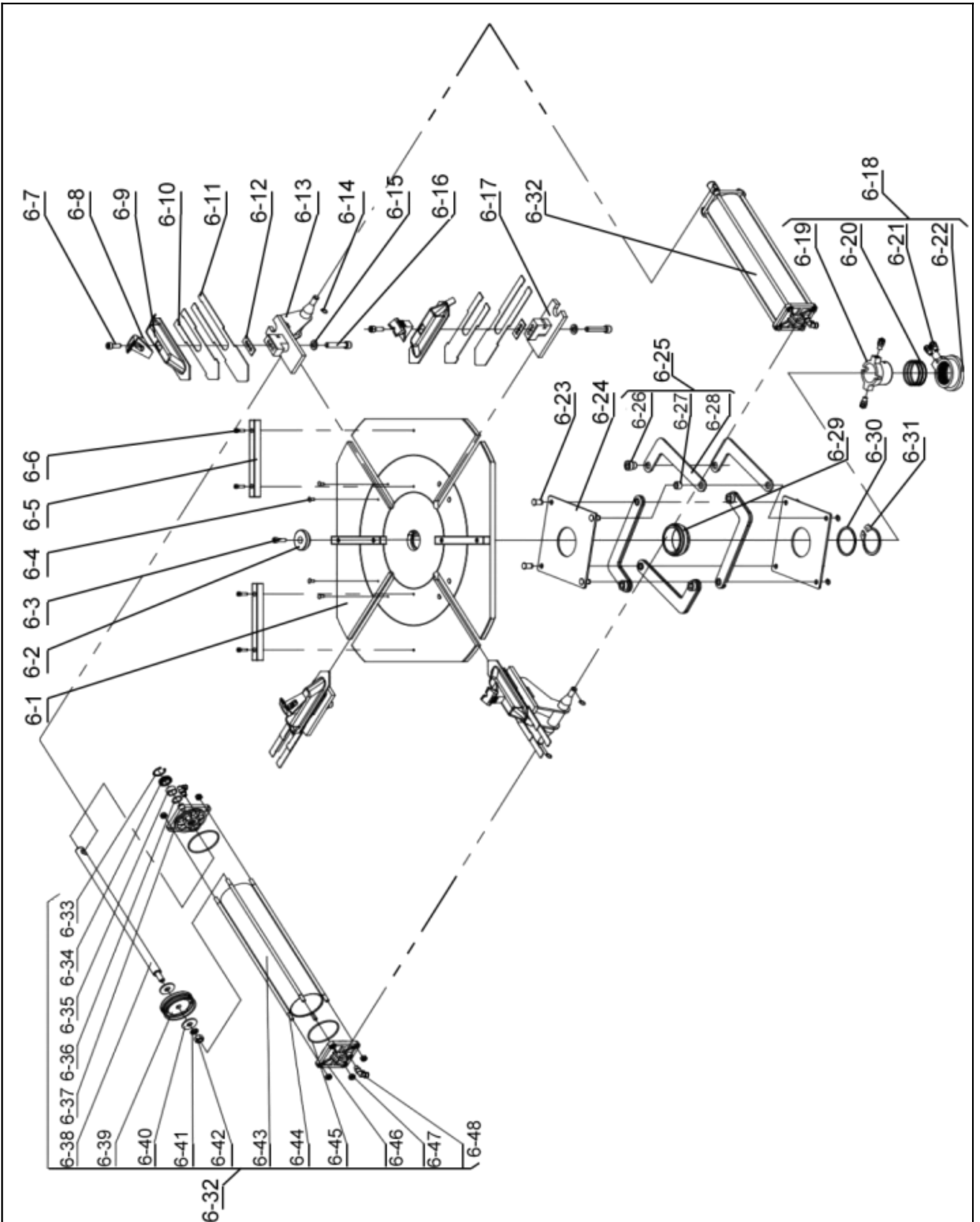

6	Turntable Ass'y						
S/N	PART#	DESCRIPTION	QTY	S/N	PART#	DESCRIPTION	QTY
1	7301000	Square plate welding	1	25	7302100	Composite of curved drawing plates	4
2	6301005	Large plate gland	1	26	6302005	Pull plate middle spacer 1	4
3	GB/T70. 1	Hexagon stud screw M 8X 25	1	27	6302003	Pull plate middle spacer 2	4
4	6311003	Aluminum rivets	8	28	7306014	Curved plate	8
5	7201006	Block	4	29	7302002	Square turntable middle sleeve	1
6	GB/T70. 1	Hexagon stud screw M 6X 20	8	30	6311004	gasket	1
7	GB/T70. 1	Hexagon stud screw M 10X 25	4	31	GB/T894. 1	Shaft elastic retaining ring 65	1
8	6301007	Transposable Claw	4	32	7306200	Large cylinder assembly	2
9	6301006	The square hole can change the boat	4	33	GB/T893. 1	Hole retaining ring 30	1
10	7301005	Upper slide	4	34	8805008	20 X30X7 without skeleton oil seal	2
11	7301004	Slides	4	35	8506511	Oil-free bearing 2013	2
12	7301006	Adjust cushion	4	36	6206020	d20X2.65 of O sealing ring	2
13	7303000	Welding of slide block of transposition cylinder hanger	2	37	7306017	Cylinder head B	2
14	GB/T894. 1	Shaft elastic retaining ring 12	8	38	7306024	Cylinder piston rod	2
15	GB/T97. 1	Flat washer A 12	4	39	7306023	Cylinder 80 piston	2
16	GB/T70. 1	Hexagon stud screw M 12X 55	4	40	GB/T96	Large gasket 12	4
17	6303100	Transposable slide block and slide plate welding	2	41	GB/T93	Spring washer 12	2
18	8809000	Gas separation assembly	1	42	GB/T52	Hexagon nut M12	2
19	8809002	Gas-dividing Body Set	1	43	7306016	80 cylinders	2
20	8809003	d60X2.65 of O sealing ring	3	44	7306022	Double head silk M8	8
21		Lock cap through terminal $\phi 8$ 1/8"	4	45	GB1235	D 80X 3. 1 of O sealing ring	4
22	8809001	Gas jacket	1	46	7306018	Cylinder Back Cover	2
23	7302004	Square turntable pin shaft	4	47	GB/T889. 1	Hexagon locking nut M8	16
24	7302001	Square turntable	2	48	PL8-01	Fast plug right angle terminal $\phi 8$ - 1/8"	4



# The options: Pnumatic Assist Arm

