

Owner's Manual & Assembly Guide

Model No. W20' x H16' PEAK SERIES L 40'



* See Inside for Detailed Safety Information.

*Gloves must be worn
at all times to reduce risk of injury!*

SAFETY & MAINTENANCE

Safety precautions MUST be followed at all times throughout the construction of your building!

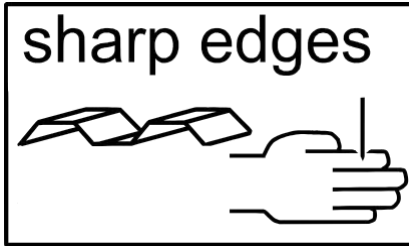

Care must be taken when handling various pieces of your building since many contain sharp edges. Please wear work gloves, eye protection and long sleeves when assembling or performing any maintenance on your building.



Practice caution with the tools being used in the assembly of this building. Be especially familiar with the operation of all power tools.



Do NOT attempt to assemble your building on a windy day. The large panels can catch the wind like a "sail", causing them to be whipped around making construction difficult and unsafe.

Do NOT attempt to assemble your building before double checking that you have all the parts indicated on the parts list as well as all hardware. Any building left partially assembled may be seriously damaged by even lightwinds.

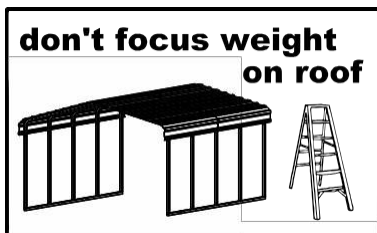

NEVER concentrate your weight on the roof of the building. When using a step ladder make sure that it is fully open and on even ground before climbing on it.



Keep children and pets away from the worksite during construction and until the building is completely assembled. This will help avoid distractions and any accidents which may occur.

IMPORTANT NOTE ON ANCHORING

1. Your building MUST be anchored to prevent wind damage. See anchoring page for more info.

2. You must also have a temporary anchoring system in place in case you need to take a break from assembly.

Exterior Care:

For a long lasting finish, clean and wax the exterior surface. We recommend washing with a mild soap solution. DO NOT use power washing to clean your shed. Using a spray automotive type wax periodically on the exterior is highly recommended if you are in a high humidity or coastal climate region.

Combustibles and corrosives must be stored in air tight containers designed for chemical and/or combustible storage. Corrosive chemicals such as fertilizers, pesticides and herbicides should be cleaned off the interior and exterior surfaces immediately. Rust caused by chemical damage is not covered by the warranty.

Rust protection precautions may help to stop rust from developing, or stop it quickly as soon as it appears.

- Avoid nicking or scraping the coating surface, inside and out.
- Keep roof and base perimeter free of debris and leaves which may accumulate and retain moisture. These can do double damage since they give off acid as they decay.
- Touch up scrapes or nicks and any area of visible rust as soon as possible. Make sure the surface is free of moisture, oils, dirt or grime and then apply an even film of high quality touch-up paint.
- Various paint manufacturers provide products for rust treatment and coverage. If surface rust does appear on your shed we recommend treating those areas as soon as possible, following the paint supplier of your choice instructions.

(1) Our customer service department can provide the paint tinting formula for matching the color of your shed.

1. **Roof:** Keep the roof clear of leaves and snow. Heavy amounts of snow on the roof can damage the building making it unsafe to enter.

Fasteners: Regularly check fasteners and retighten as necessary.

General: Wash off inked part numbers on coated panels with soap and water.

Please note, Manufacturer cannot be held responsible for any consequences due to buildings that are not installed per these instructions, or for damage due to weather conditions or acts of God. **Keep these assembly instructions and owner's manual for future reference.**

ASSEMBLY TIPS & TOOLS

Watch the Weather Closely: Be sure the day you choose to install your building is dry and calm. Do **NOT** attempt to assemble your building on a windy day. Be careful on wet or muddy ground.

Use Teamwork: Two or more people are required to assemble your building. One person can hold the parts or panels in place while the other person fastens them together and handles the tools. This makes the process of assembling your building faster and safer.

Tools and Materials: Here is a list of some basic tools and materials you will need to assemble your building. Decide which method of anchoring and the type of base you will use to make a complete list of the materials you will need.

WHAT YOU NEED

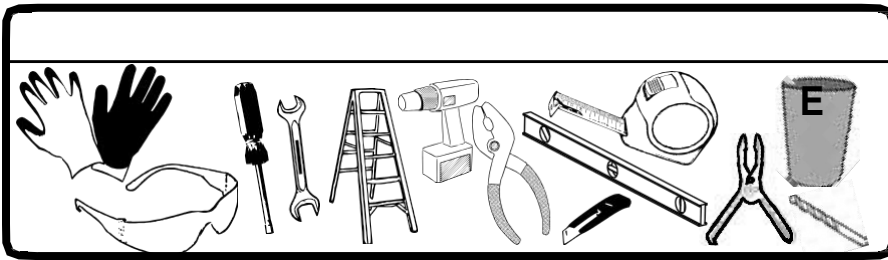

- Work Gloves
- Safety Glasses
- Nut Driver or Wrench
- Step Ladder 8'
- Power Drill (Cordless, Variable Speed)
- Pliers
- Utility Knife or Scissors
- Carpenter's Level
- Tape Measure
- Clamp
- Grout (Asphalt Base)
- 7/8" x 13" Masonry Bit (Asphalt Base)
- 1/2" x 8" Masonry Bit (Concrete Base)

RECOMMENDED TIME SAVERS

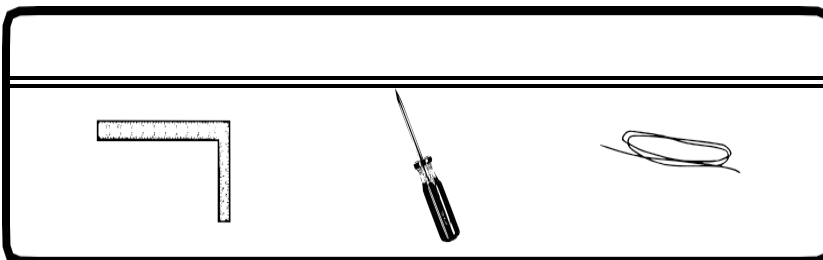

- Square
- String (for squaring the frame)
- Awl (to align holes)

How to Select and Prepare Your Building Site: Before you start to assemble your building, you will want to decide on a good location. The best location is a level area with good drainage.

1. Allow enough working space so it is not difficult to move parts into position for assembly. Also, there needs to be enough space outside the building to be able to fasten the panel screws from the outside.

- Before assembling any parts, your base should be constructed and an anchoring system should be ready to use.

PLEASE READ AND UNDERSTAND INSTRUCTIONS COMPLETELY BEFORE ASSEMBLY. LAY OUT FRAME PARTS AS BELOW:

No	Description W20'L40'H16' 2m Spacing	QTY
1	Roof Bent Tube ϕ 40*1.48m	5
1A	Roof Bent Tube(Door)	2
2	Upper Bent Tube ϕ 40*2.16m	10
2A	Upper Bent Tube(Door) 52CM SHORTED TUBE	4
3	Middle Bent Tube ϕ 40*1.56m	14
4	Lower Bent Tube ϕ 40*2.16m	12
4A	Bent Tube for front and back door	2
5	Purlin ϕ 40*2.04m	30
6	MiddleBasePlate 26CM	10
6L	Left Corner Base Plate	2
6R	Right Corner Base Plate	2
6A	MechanicalDoor LeftBasePlate	2
6B	MechanicalDoor right Base Plate	2
7	Stake Peg \ Expansion Bolt M12	64
8	MechanicalDoor Left Lower Post	2
8A	MechanicalDoor Right Lower Post	2
9	MechanicalDoor Left Upper Post	2
9A	Mechanical Door Right Upper Post	2
10	MechanicalDoor Cross Beam 3*5*1.9m	4
10A	Door Cross Beam Vertical Support Tube 3*5*1.07m	2
11	Shoulder Purlin ϕ 40*0.88m	4
12	Squre Tube For Mechanicalwheel 4*6*0.88m	2
12A	Mechanicalwheel with steel wire 21m	2
13	Vertical pipe for front and backdoor ϕ 32*1.9	2 GROUPS
14	Door Lower Tension Tube ϕ 32*2.25=10 / 1.32=2	2 GROUPS
15	Plastic Plug	12
16	Front and Back Cover Lower Tension Tube ϕ 32*0.82m	4
17	Carriage Bolts M8*60	168
18	Carriage Bolts M8*80	35
19A	Bolts M12*30	24
20	Bolts M10*90	56
21	Ratchet tie down	14
22	Ratchet tie down belt	14
23	Rope 80M	1
24	Roof Cover	1
25	Front and Back Cover	2
26	Clips	4

27	Steel wire at sideface	3.5M	12
27A	Angleiron		6
28	Fish Joint		8
29	PVC tube		2 GROUPS
30	Small ratchet with belt		24

SPECIFICATION

Width: 6.1m Length: 12m Height: 4.88m

Door dimension: W12*H10ft (W3.66m*H3.05m)

NOTE:FRME EXTENSION KIT

This is the base frame dimension. Your model may have more or less middle ribs than shown in the illustration . You will receive more extra ribs for every extra arch spacing of building length that you purchase. The basic frame assembly will remain the same. The cover will be the correct size for the length of the building.

A. PLOTTING THE FRAME:

Before building your shelter, you should choose a flat area on your property and plot your shelter.

- A. Stake out the area for the shelter in the desired spot. The width of the area should be at least equal to the width of the shelter and the length should be equal to the length of the shelter.
- B. Measure diagonally from centre to centre of the tubes. These measurements should be the same. If they are not equal the stakes need to be adjusted until the width, length and inside measurements are correct.

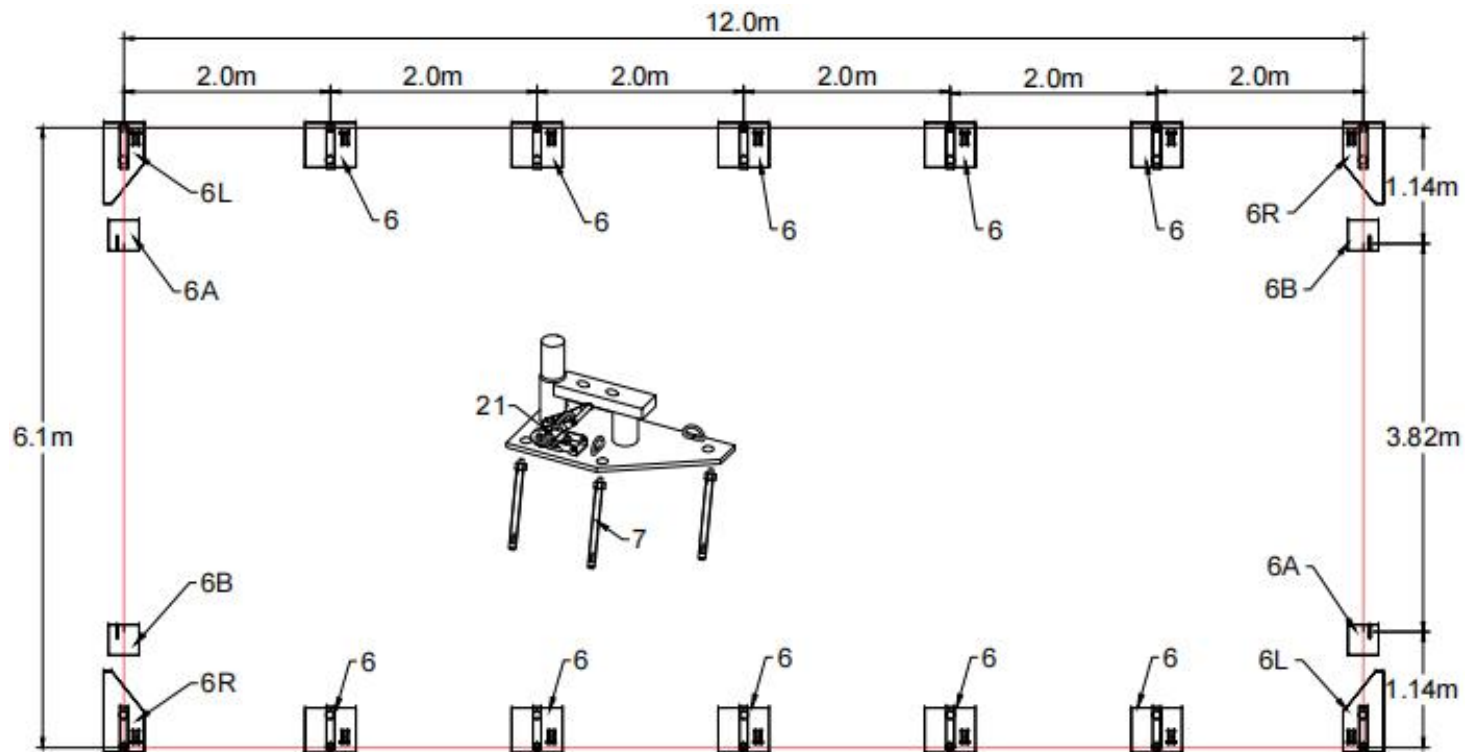

Figure 1

B. FOUNDATION PLACEMENT

As **Figure 1** show each Base Plate is equipped with three pieces of Stake Peg (No.11).

Note: The Stake Pegs apply for normal conditions, not suitable to the rock ground, frozen soil and concrete ground.

C. ASSEMBLE END AND MIDDLE RIBS

Assemble end and middle ribs as shown. Securely fasten all of the joints with the hardware indicated.

- As Figures shown to find one Roof Bent Tube, Middle Bent Tubes, Lower Bent Tubes and assemble every group arch with Bolt
- DO NOT install the screw on the top of the truss where the fabric will rest.
- As shown to fix Roof Support Tube by using Bolt if your products is the PLUS model.
- Lift an assembled arch onto one base plate and force the other end of the arch onto the opposite base plate.

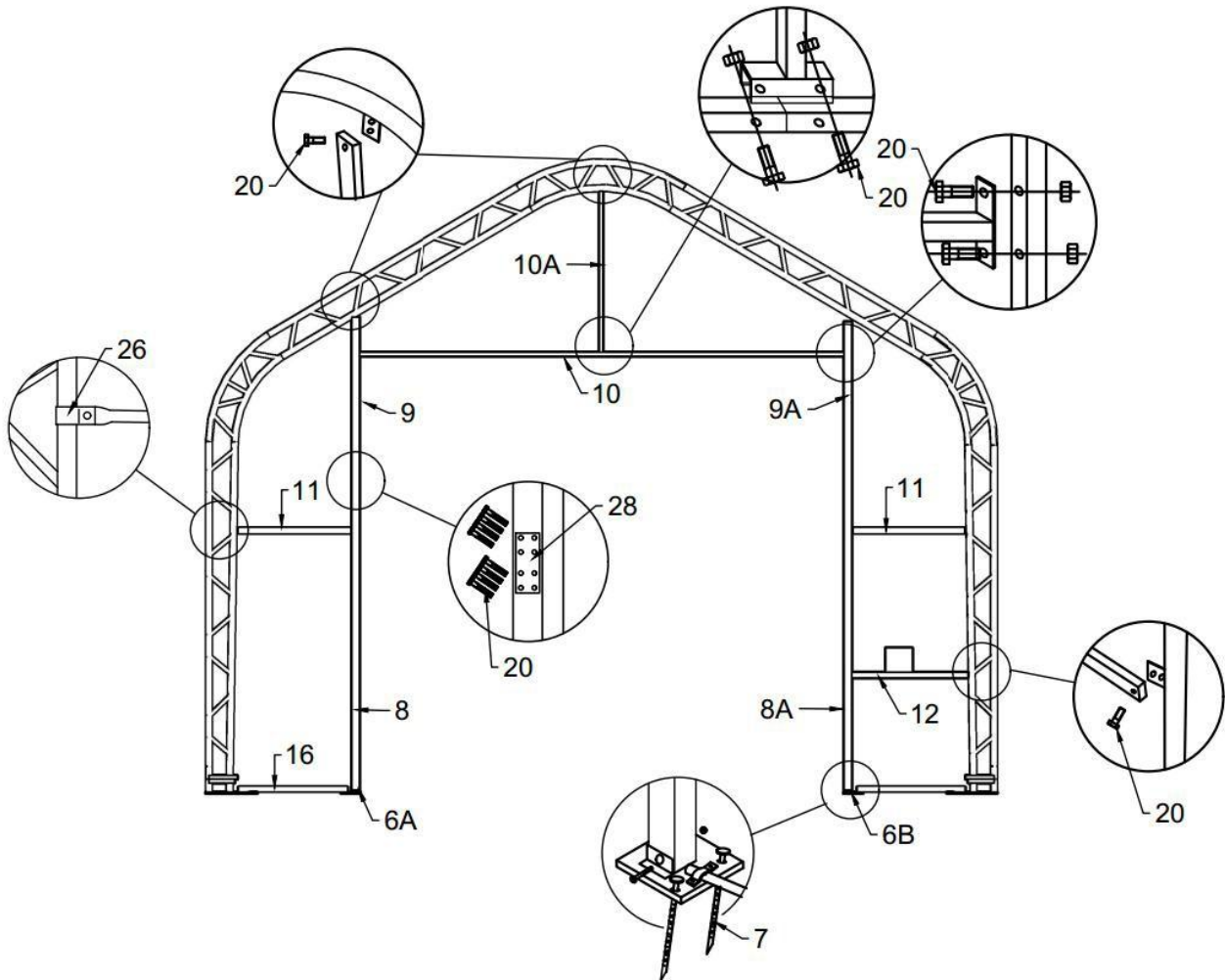

Figure 2

WARNING

SAFETY TIPS

Always wear proper safety equipment such as safety glasses and gloves

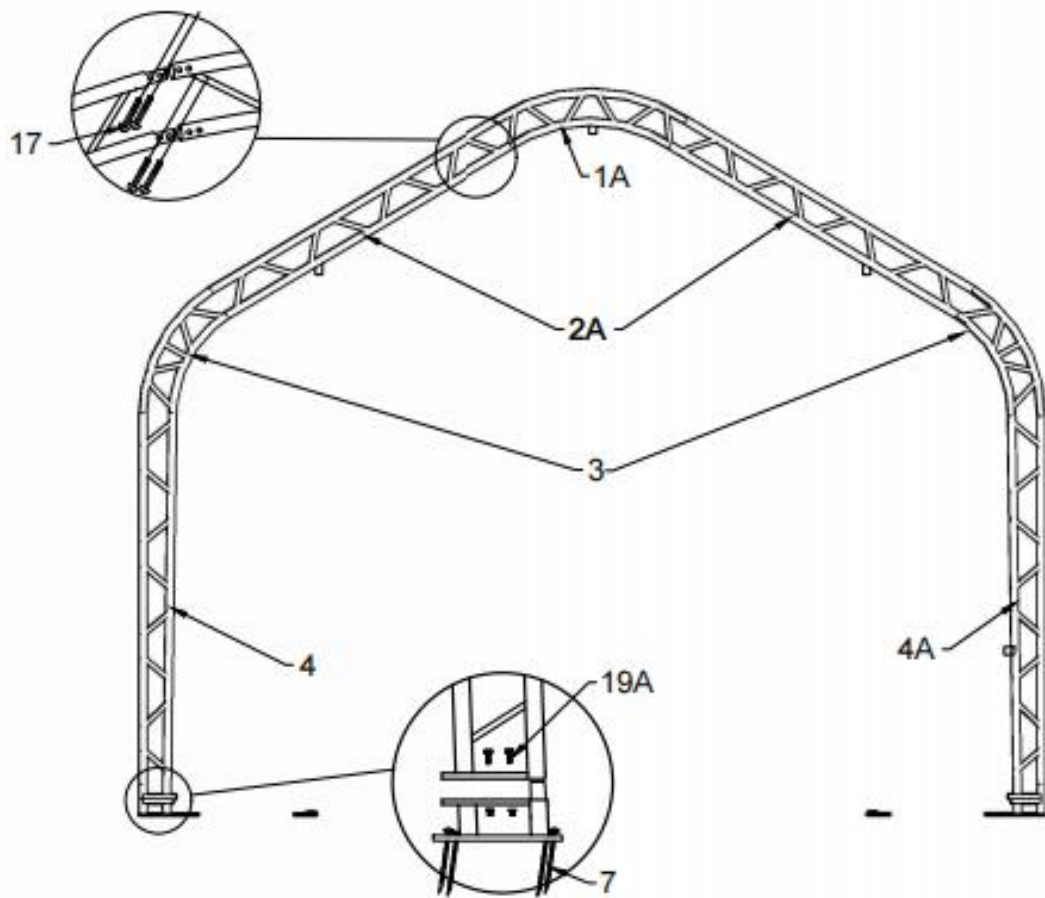

Figure 3

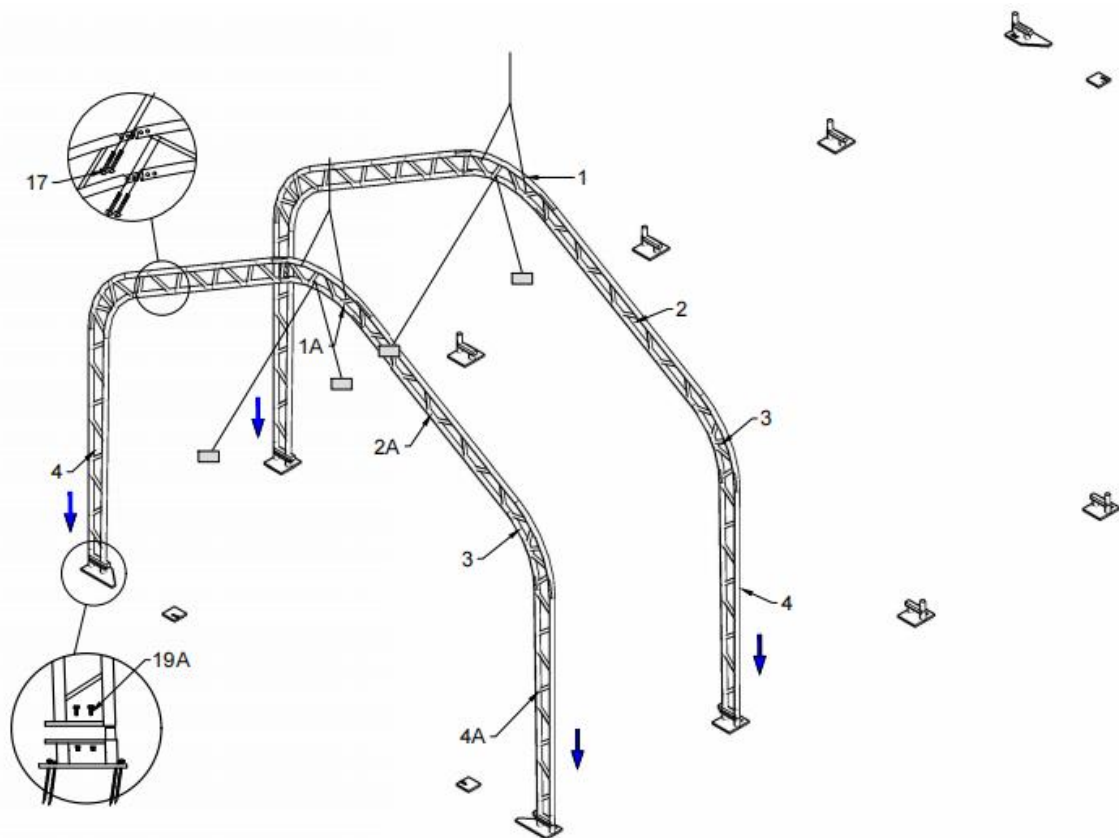

Figure 4

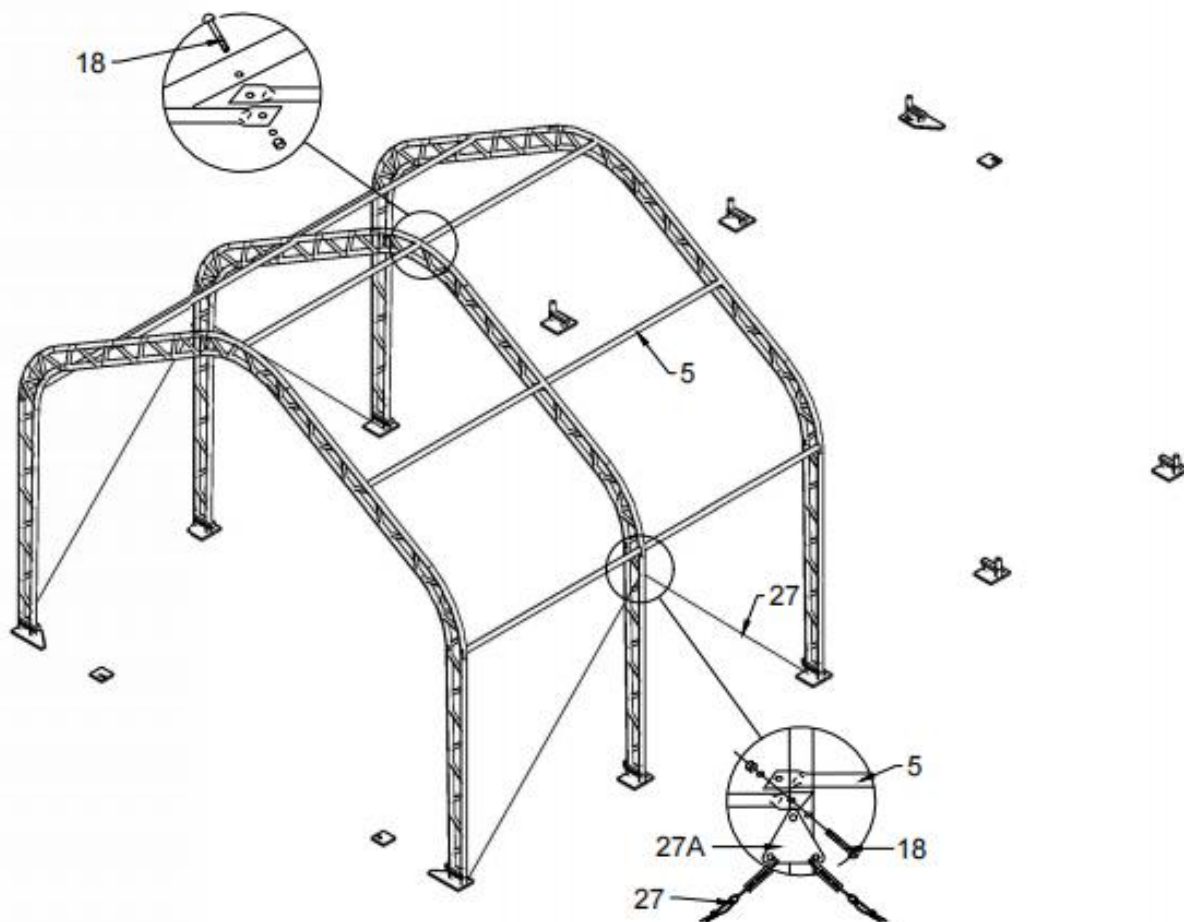

Figure 5

3.4. Assemble middle ribs as shown, Securely fasten all of the joints with the hardware indicated.

When finish installing the first two arches into the base plates, Install top and side rail using Roof & Sidewall Purlin to connect them by Screw. After that install the third arch, insert the third arch into the base plate, Connect all remain ribs and connect them by the top and side rails.

Attation: Install top rail and side rail

Place assembled first end rib in the staked area. Place the on the uprights. From the outside of the rib insert the bolt through the upright and then through another rail tubes

NOTE: Sliding Cover Rails should be attached to frame, once cover is placed over the frame.

Attach Wind Brace between the end rib and the first middle rib as shown

Bolts attached at the cross rails should be inserted facing inside the shelter.

THINK SAFETY, EVERYDAY!

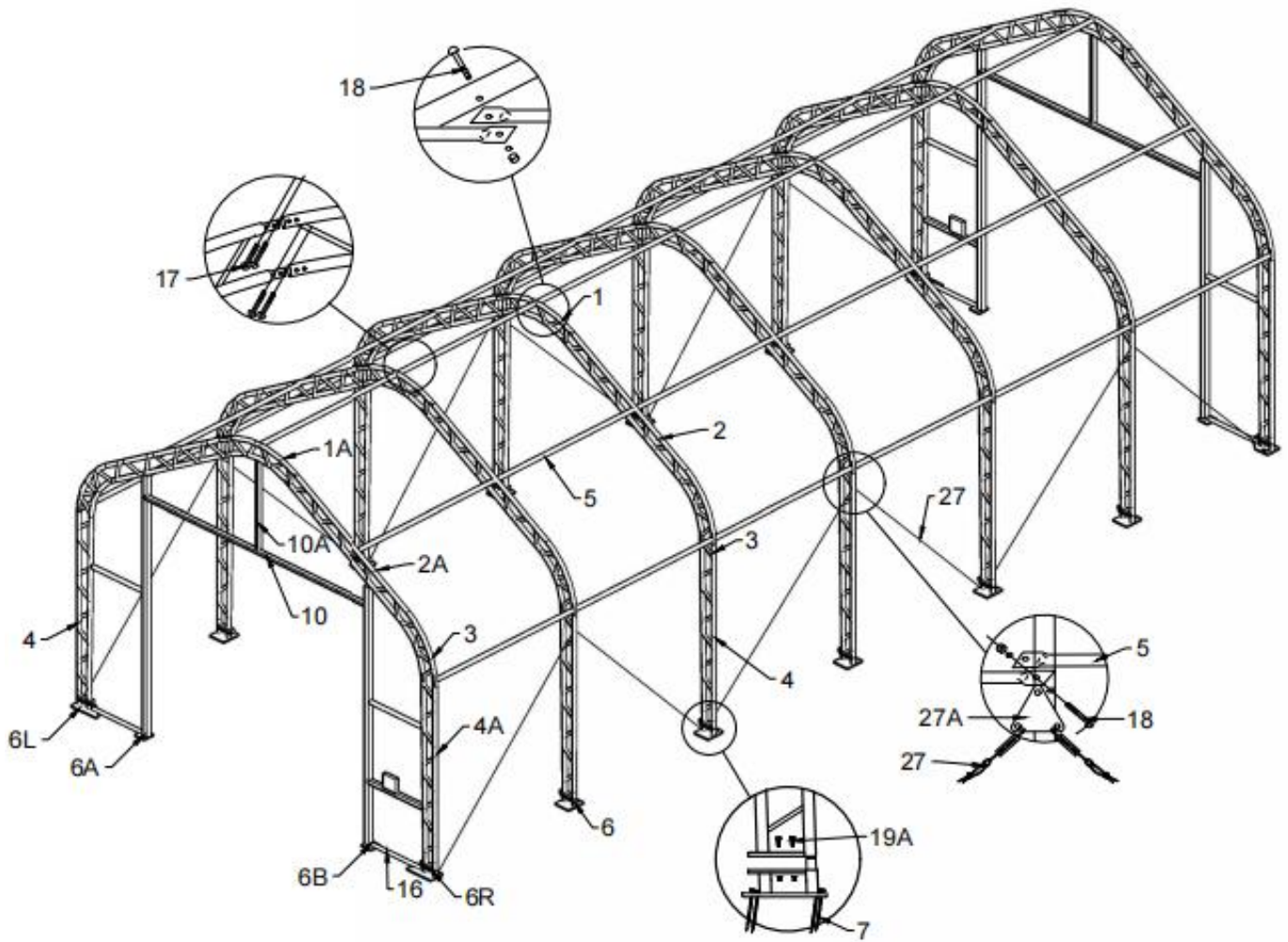

Figure 6

D. **SQUARING UP THE FRAME**

1. Be sure the frame is in its final location, which needs to be as flat and level as possible.
2. Measure across opposite corners.

these distances must be equal to within 1 inch.

A. Check that the front and rear of the frame measures is right in width.

WARNING: Serious injury to persons or property could result if cover is installed and shelter is not completed and is left unattended. Shelter must be securely anchored until completed.

E. **END AND DOOR PANEL INSTALLATION**

- Use the supplied Nylon Band (Part No. 16) to tighten the roof cover to the end arches. The Nylon should be cut as your requirements when using. Fasten the Nylon Band at the bottom edge, then roof cover is tightened.

- Insert the Lower Tension Tube into the bottom of Front and Back cover
- Put the Nylon Rope to fix it onto the Base Plate for Corners .
- Tidy the Back Cover and Front Cover. Fasten the band inside the end of the roof cover, make the cover well fold to the frame and tie the end of the band to the Clips on Base Plate for four corners.

6. INSTALLING THE COVER ON THE FRAME

NOTE: DO NOT install the cover onto the frame of your building in high wind conditions. A slight breeze is the most advantageous for cover installation. To take advantage of the breeze, pull the cover up over the arches with breeze blowing in the cover like a sail filled with air.

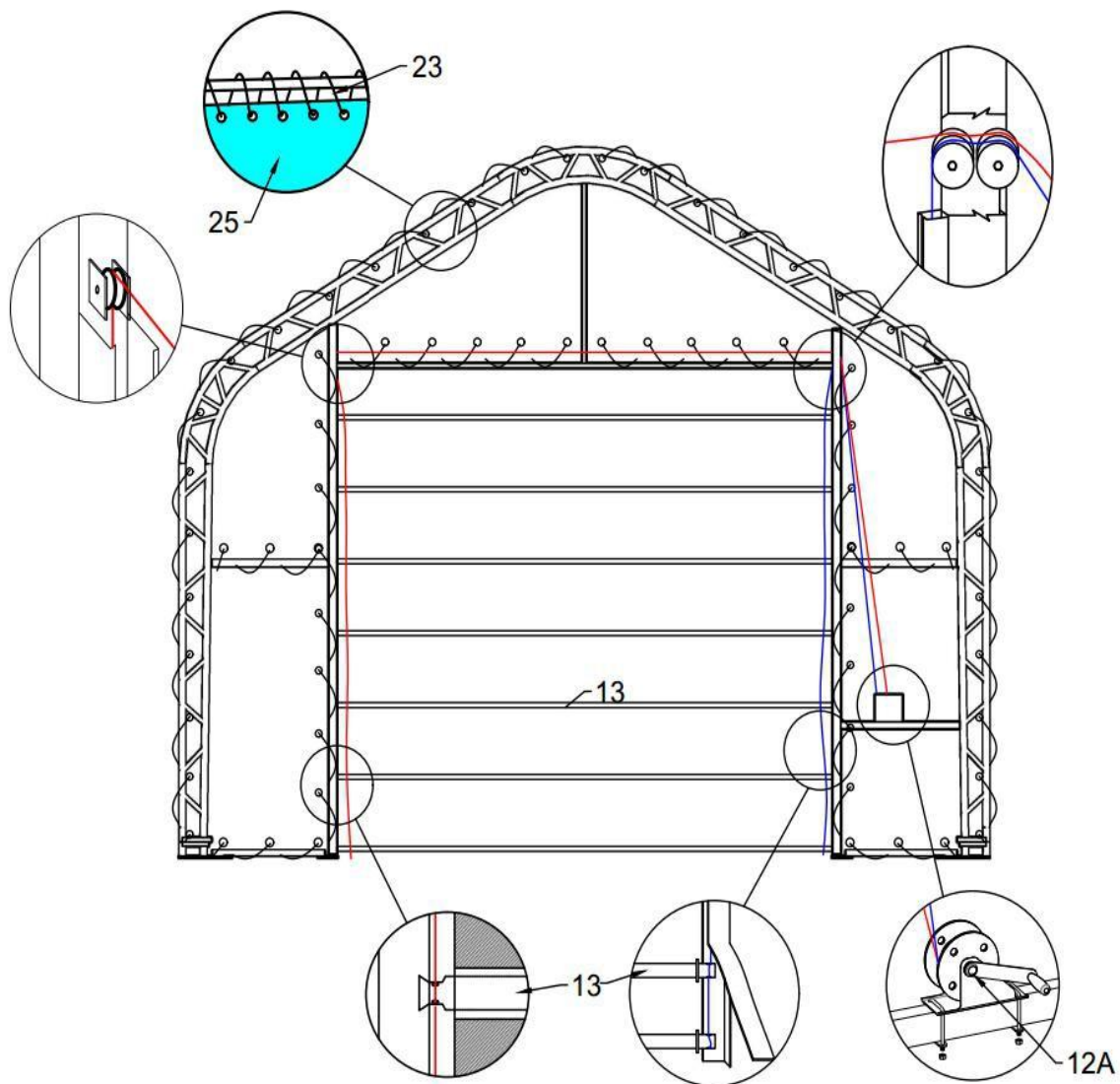

Figure 7

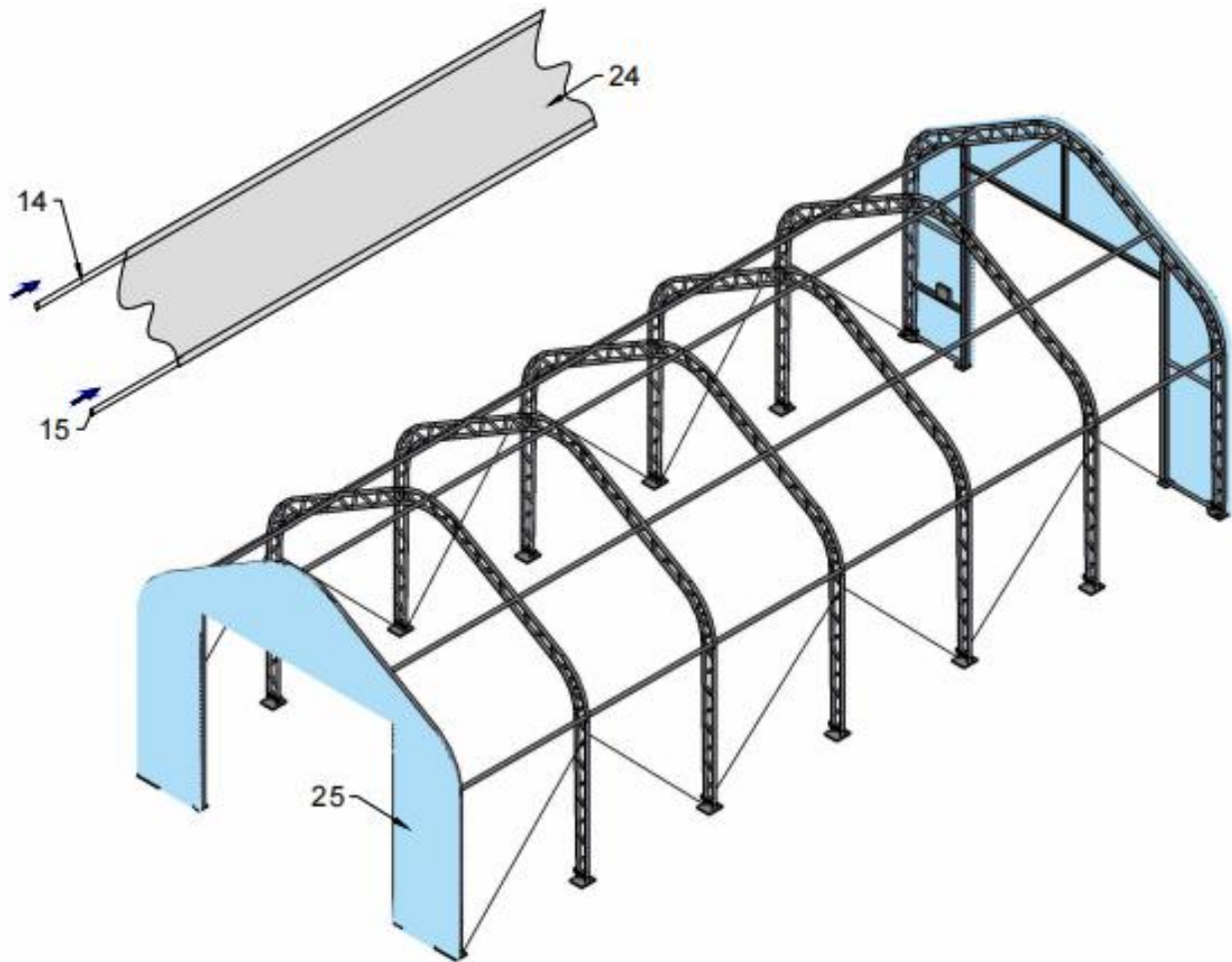

Figure 8

- Assemble Tension Tube for Roof Cover before installing the cover.
- Roll out the roof cover on a ground sheet. Align the cover evenly to each end of the frame.

Note: Be sure doing not pull over the end of the roof cover.

- Pull the cover over the frame **EVENLY, CAREFULLY AND SLOWLY. DO NOT TIGHTEN.** Adjust the cover so that it is square and evenly centered on the frame. Put the lower tension tube and insert them into the bottom pocket of roof cover.

Note: The end flaps must overhang evenly at both ends.

- With the end flaps flipped back and out of the way, use the supplied Nylon Band to tighten the roof cover to the end arches. The Nylon should be cut as your requirements when using. Fasten the Nylon Band at the bottom edge. Drive the Ratchet Tie Down forth and back and then roof cover is tightened. **NOW THE INSTALLATION IS FINISHED.**

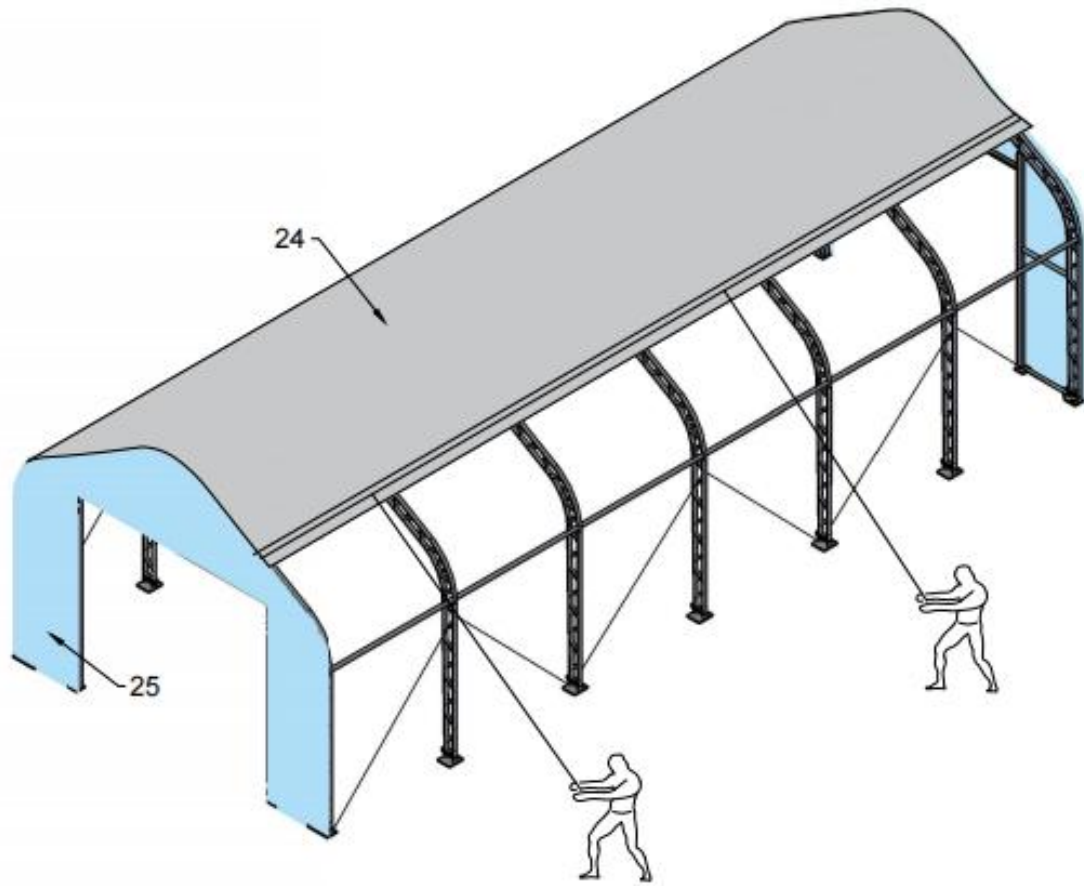

Figure 9

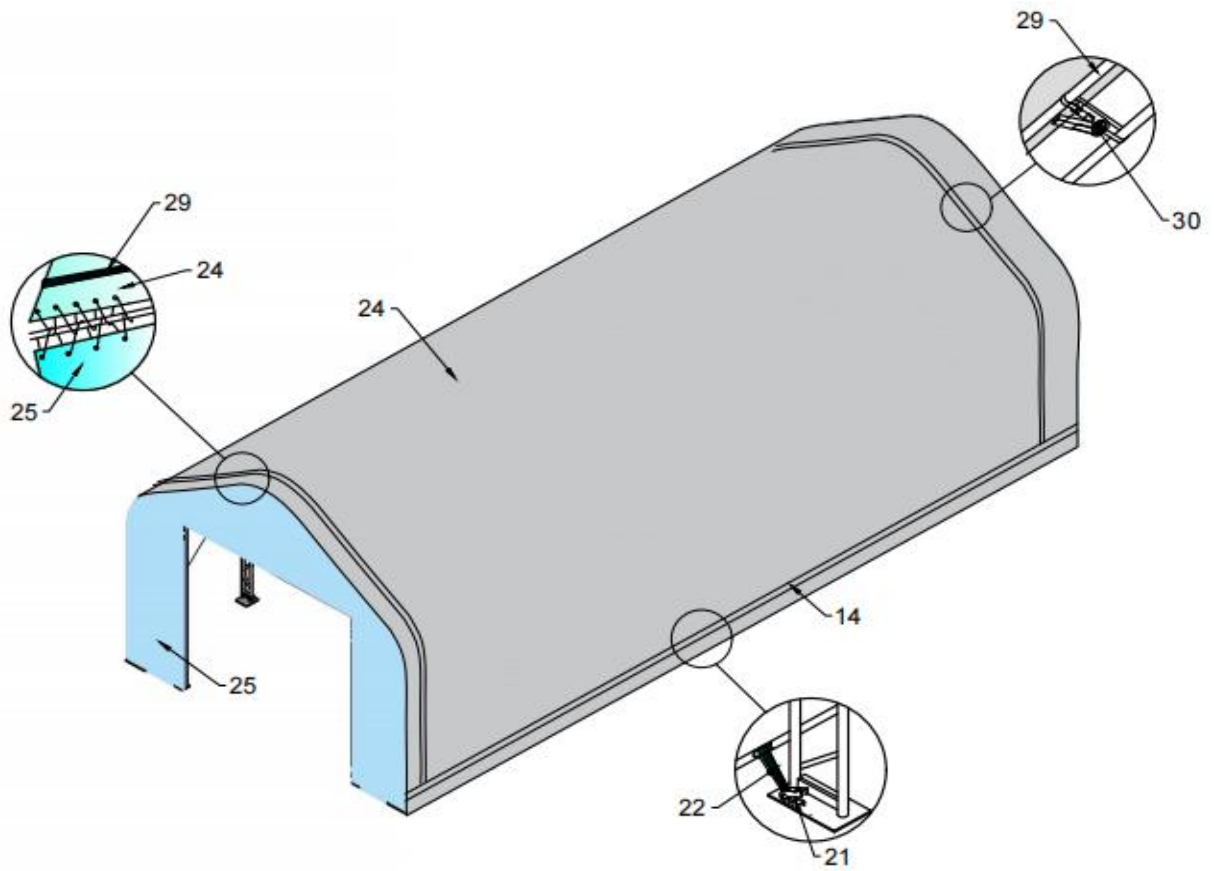

Figure 10

NOTE:

- Cloth tape for wrapping the gaps on the frame after frame installation.
- Please adjust the roof cover every month. It's necessary to make the cover flat and well tensioned.

Confirm that all the hardware and parts are present before attempting to assemble your storage unit.

For missing or damaged parts contact customer service. Do not return to store
Customer Service www.gmshelter.com
info@gmshelter.com



**SAVE THIS MANUAL
FOR FUTURE REFERENCE!**

RETURN AND WARRANTY INFORMATION

WARRANTY INFORMATION

WHAT IS NOT COVERED UNDER WARRANTY:

Manufacturers/distributors/retailers of these products are not responsible for the following:

- Used products;
- Any product that that been used, altered, or modified in any way;
- Depreciation;
- Damage caused by lack of reasonable and proper maintenance;
- Failure to follow instructions, directions, drawings
- Improper installation, misuse or lack of proper protection during installation, use or storage;
- Damage resulting from accident or falling objects;
- Damage due to normal maintenance or lack thereof;
- Exposure to harmful chemicals, fumes, or other substances, foreign or natural in the atmosphere;
- Acts of God, which includes but is not limited to, wind damage, excessive snow load, flood, hail, tornado, sleet, ice, fire;
- Unforeseen causes or circumstances, such as but not limited to: added load to the structure, or any other external forces
- Product which is not in the possession of the original purchaser;
- Structure is not properly anchored or installed;
- Third party installation fees are not covered under warranty

- Loss of income, wages, travel expenses, personal property, equipment rental, fuel, and/or property value are not recoverable
- Any condensation damage to the product and its contents.

End panels are excluded from any warranty regardless of the product series or classification.

FAILURE DUE TO IMPROPER INSTALLATION OF THE PRODUCT IS NOT COVERED UNDER WARRANTY

If a product/part is deemed to be defective & not caused by the purchaser and within the warranty term limits, Our company will provide replacement parts at no charge to the purchaser. Examples of defective parts are (but not limited to): torn covers, holes in cover, bent bolts, broken ratchets.

RETURN INFORMATION

GM SHELTER Limited does offer product return with a 10% restocking fee. It is also the customer responsibility to pay for returned product shipment to and from the final destination. It is also customer responsibility to arrange delivery of the returned product to the manufacturer in the original condition (which includes packaging). Upon suitable assessment of the returned package, the refund will be provided. Suihe Limited reserves the right to decline product returns under certain conditions.

Product ordering and payment constitutes acceptance of the terms and conditions stated above.

TERMS AND CONDITIONS

We strive to provide the best products and services at a reasonable price for potential and ordering customers. This informational instruction is targeted to provide as much informational material as possible in order for potential customers to make an educational decision. Our products are designed to provide an optimal shelter solution at a reasonable cost. The terms and conditions below apply to the products described on this website.

GM SHELTER Limited also assumes no responsibility for any "human caused" or "animal" related incidents. This list includes (but is not limited to) the following: fire, vandalism, chemical interaction, falling objects, damage caused by animals or insects, **misassembly, improper anchoring, lack of proper maintenance/care**, and additional weight added to the inside or outside of the structure.

GM SHELTER Limited is not responsible for any of the following as a result of usage of these fabric structures. This list includes (but is not limited to) the following: loss of wages, loss of income, depreciation, property damage, litigation costs, equipment or vehicle rental, equipment damage, construction costs, fuel costs, appraisals, livestock or animal loss, and bodily injury or death. Suihe Limited strongly recommends purchasing insurance for all structures in the rare event of damage due any of the above stated items.

Although our shelter products are considered "temporary/portable structures" and typically do not require building permits, Suihe Limited recommends all prospective purchasers consult local authorities on building permits prior to purchase.

Although our fabric structures perform well under a variety of weather conditions, no snow or wind load ratings are provided due to the "portable structure" nature. As a result, GM SHELTER Limited assumes no responsibility for damage or destruction caused by any Act of God. This includes (but is not limited to): wind, snow, hail, lightning, hurricanes, tornadoes, volcanoes, rain, avalanches, fire, or flooding.

Product purchase constitutes acceptance of the above terms and conditions