

Model #	CL-8103-TBK
SKU	20097
Description	Large Coach Light
Finish	Textured Black
Glass	Clear
Dimensions- HxW (Dimensions shown in inches)	18.75" x 10.5"
Lamp Info	4X60W (C)

Finish/Glass Shown: Textured Black / Clear

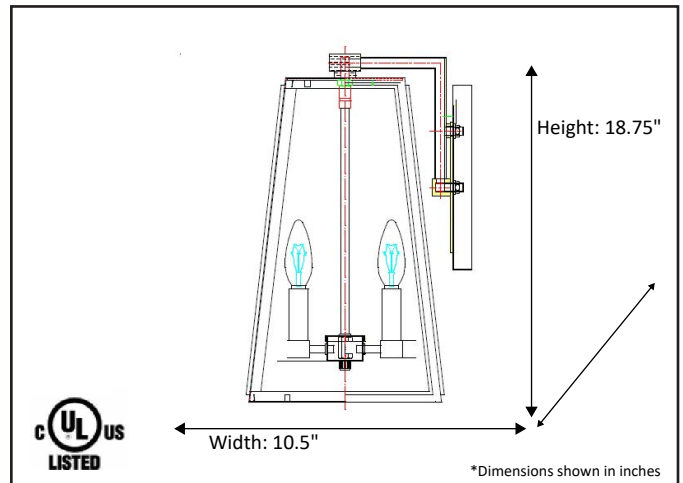

*Lamps not included



ELECTRICAL REQUIREMENTS: Fixture requires a grounded electrical supply line of 120 volts AC.

INSTALLATION REQUIREMENTS: Fixture attaches to electrical junction box securely anchored in wall or ceiling.
All mounting hardware included.

HOMEnhancements/ 1505-A Kelly Blvd., Carrollton, TX. 75006

Product specifications subject to change without notice.

REFERENCE	QTY.	REMARKS	Project
			Location/Type
			Architect
			Engineer
			Contractor
			Submitted By: Date: