

Model #	CL-2146-TBK
SKU	18626
Description	Hanging Coach Light
Finish	Black
Glass	Clear Seeded
Dimensions- HxW (Dimensions shown in inches)	12" x 7.25"
Lamp Info	1 x E26

Finish/Glass Shown: Black/Clear Seeded

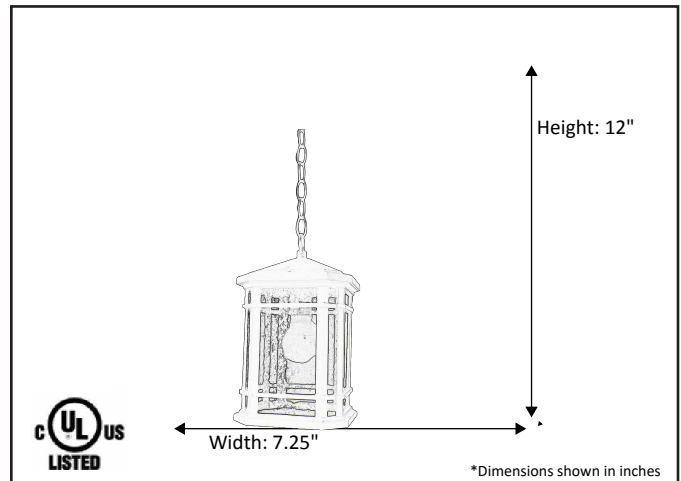

*Lamps not included



ELECTRICAL REQUIREMENTS: Fixture requires a grounded electrical supply line of 120 volts AC.

INSTALLATION REQUIREMENTS: Fixture attaches to electrical junction box securely anchored in wall or ceiling.
All mounting hardware included.

HOMEnhancements/ 1505-A Kelly Blvd., Carrollton, TX. 75006

Product specifications subject to change without notice.

REFERENCE	QTY.	REMARKS	Project
			Location/Type
			Architect
			Engineer
			Contractor
			Submitted By: Date: