

PODBOOTH

DESIGN o4i Design Studio

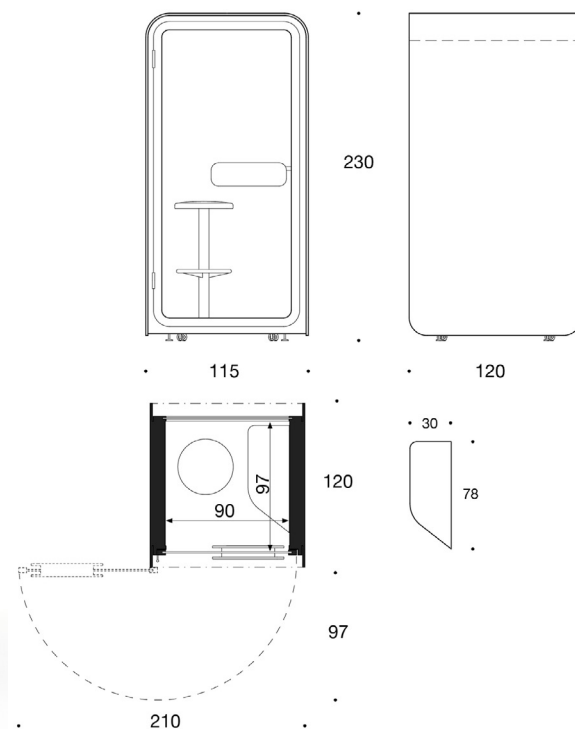

Material description:

Exterior:

Sound-absorbing, tempered and laminated glass.
Acoustic walls and ceiling.
Exterior surface upholstered.
Glass frames and door handle black laminate.

Interior:

Dirt repellent and anti-static carpet, black.
Walls and ceiling felt, dark grey.
Tabletop and backplate black laminate.

Dimensions:

Outside:

Width 115 cm x depth 120 cm x height 230 cm.

Inside:

Width 97 cm x depth 90 cm x height 200 cm.

Room height min.: 250 cm.

Standard equipment:

Castors.
Levelling glides.
LED lighting and air circulation system with occupancy sensor.
Integrated tabletop.
Electric socket and charging USB.
The cable location can be selected during installation.
Magnet closing door.
Left handed door.

Accessories:

Integrated seat with a foot ring, base black.
Seat available with several upholstery options.
Wall-mounted coat hanger holder with or without a mirror, black.
Coat hanger, black.

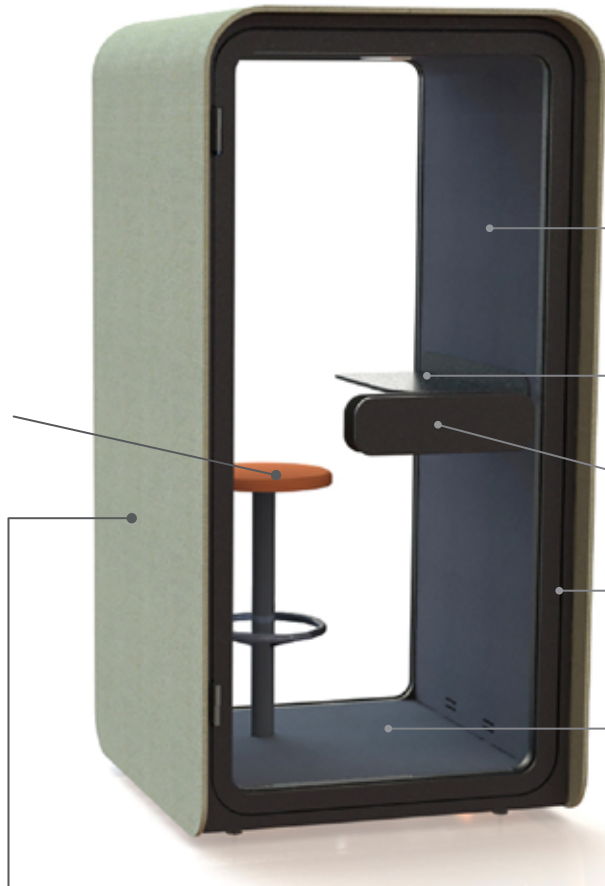

Seat fabric:

- standard fabric from Martela collection

Fabrics:

Breeze Fusion	BF
Capture	CPT
Chili	CH
Crisp	CR
Felicity	FE
Medley	MED
Swing	SW
Soul Melange	SOM

The inner wall & ceiling:

- dark grey felt

Table top & back panel:

- black laminate

Handle:

- black laminate

Door and window frames :

- black laminate

Floor:

- dirt repellent & anti-static carpet, black

