



Spécifications techniques

Puissance (bouton sur la lampe pour modifier la puissance)	100 Watts –Total 18 000 lumens 150 Watts –Total 25 500 lumens 200 Watts –Total 32 000 lumens
Lumens/Watt	100W : 180 Lumens/Watt 150W : 170 Lumens/Watt 200W : 160 Lumens/Watt
Norme	IP66
Angle	150 x 90°
RA	> 70
PF	> 0,95
ULR	< 3%
Protection de surcharge	6KV / 10KV
Couleur d'éclairage ajustable (bouton sur la lampe pour modifier la couleur)	3000k / 4000k / 6000k
Tension d'alimentation	100-277 V
Durée de vie minimum	100 000 Heures
Fréquence	50 - 60Hz
Matériau	Aluminium moulé sous pression
Pièces / source LED remplaçables	Oui
Nombre de LED	336 pièces
Type de LED	Philips Lumileds SMD 3030
Transformateur	BQ Driver
Couleur	Bronze foncé
Température de fonctionnement	-40°C / +50°C
Température de stockage	-40°C / +70°C
Dimensions produit	42,7 x 30 x 6,5 cm
Dimensions emballage	61 x 34,5 x 12,5 cm
Dimmable	0 à 10V
Certification	CE & Rohs, ETL, cecl, DLC 5.1 Premium
Poids	6.65 kg
Garantie	5 ans

PUISSANCE AJUSTABLE
100/150/200
Watts

150x90°

GARANTIE
5
ANS

CCT
3000k-6000k

PHILIPS
LUMILEDS

DIMMABLE
0 - 10V



En option :
- Capteur crépusculaire
- Détecteur de mouvement
- Télécommande

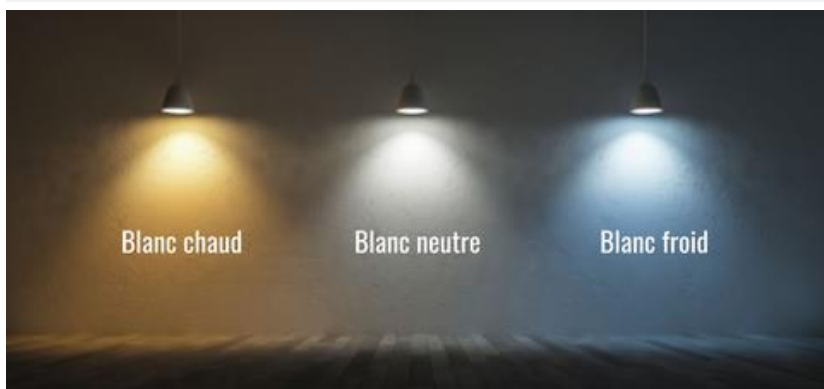
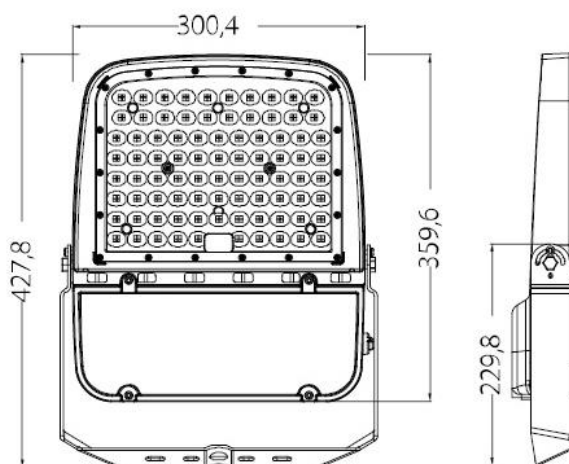
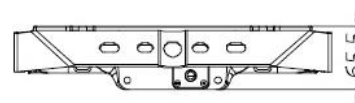

Couleur de température AJUSTABLE !

- 1 Projecteur, 3 couleurs de température !
- Blanc chaud 3000K
 - Blanc neutre 4000K
 - Blanc froid 6000k

Ajustez la couleur d'éclairage comme bon vous semble, directement avec le bouton réglable !





FRANCE VISION
DISTRIBUTION

Projecteur LED filaire

Série ULTIME P1

CCT (Couleur Changeante en Température)

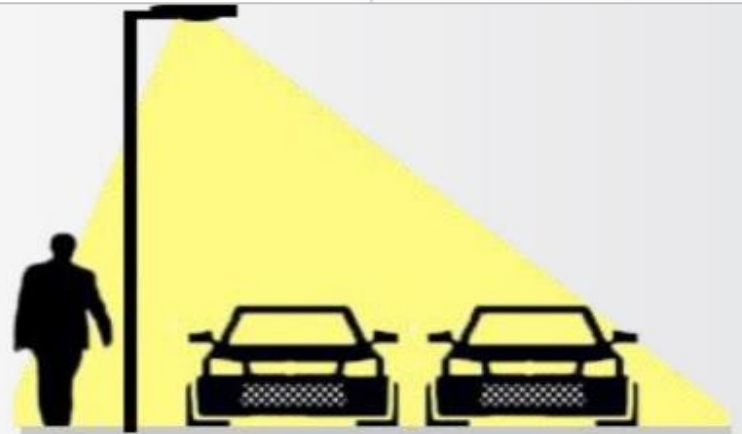
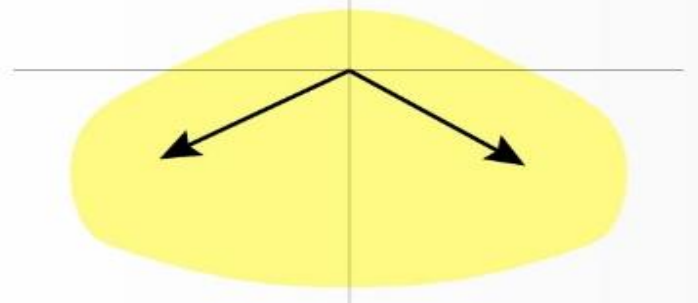

ACCESSOIRES EN OPTION

DÉTECTEUR DE MOUVEMENT



CAPTEUR CRÉPUSCULAIRE



TÉLÉCOMMANDE

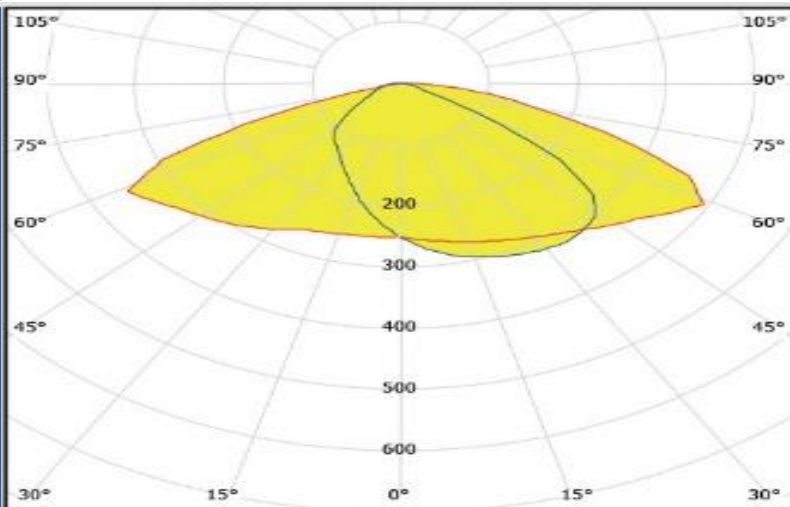

FRANCE VISION
DISTRIBUTION



France Vision Energie
46 bis avenue du Maine – Centre Multiburo – Quartier Montparnasse - 75015 Paris France



09 74 55 07 59



info@france-vision-distribution.com



www.france-vision-distribution.com

RCS Evreux SIREN 847645819 - APE 4690Z - TVA Intra FR19847645819