

Commercial Ice Maker

Instruction Manual

SKU: IM-02P

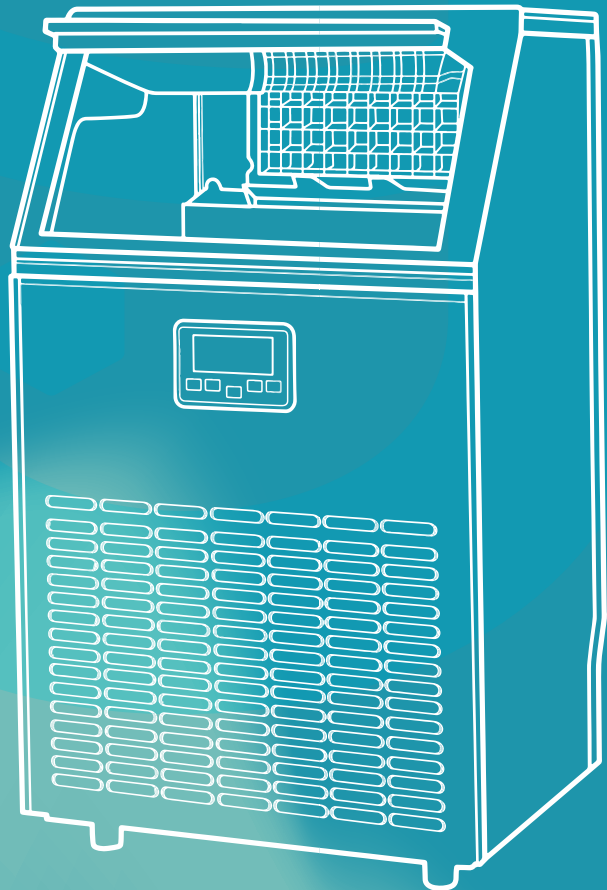

Congratulations

Dear Customer:

Welcome to the Euhomy family. Thank you for purchasing one of our products.

Our goal is to provide you with superior service. If there is anything missing from or wrong with your order, or if you have any questions about using our ice maker, PLEASE contact us.

Email: support@euhomy.com

Facebook: [@Euhomy.Official](https://www.facebook.com/Euhomy.Official)

The Euhomy team is available 24/7 to address your questions, comments, and concerns. Your satisfaction is our ultimate goal. We want to make everything right so you'll share your positive experience with other shoppers on Amazon.

If you experience any problems, please send an email to support@euhomy.com.

Our mission:

* To be the most trusted appliance brand.

* To create practical, compact appliances that better your life.

Be sure to register at
www.euhomy.com/register
for updates, warranty, and other relevant information.

I Q&A

1. How often do I need to clean my ice maker?

Depending on how frequently you use it, it is recommended that you clean it at least once a week. Failure to clean the machine will cause scale accumulation, which will eventually block the pump and cause the product to stop working properly.

2. How should I clean the machine?

It is recommended to use lemon water or weak acid vinegar for cleaning. Drain immediately after cleaning, and then clean it with pure water.

It is recommended to drain the water at least once every three days (pulling out the small hose on the right side of the water tank). Draining will not only ensure that the hardness of the water is not too high, but also ensure that impurities can be discharged well, and it is not easy to produce scale in the water tank.

3. Why is my ice cube cloudy?

It means that the water quality is turbid. It is recommended to use drinking water and distilled water. If your water quality problem is serious, it is recommended that you install a water filter kit.

4. Can I put milk and juice into the water tank to make ice cubes?

We recommend that you do not do that. Our research has found that the high concentration of milk and beverages can easily block the pump and reduce the life span of the pump. At the same time, the protein in milk is prone to calcification, which chemically reacts with the PU water pipe inside the machine, which easily breaks it, making the product unable to continue working.

5. Why does my ice cube melt easily?

Since the ice maker is not a refrigerator, it does not have a heat preservation function. The high ambient temperature in summer will accelerate the melting of ice cubes. You can close the lid of the machine to keep the internal temperature. Some customers also put electric fans on the side of the machine to blow away the hot air surrounding the device, thus solving the problem. Feel free to try it yourself. However, if you are not using ice cubes for a long time, we recommend removing them from the ice basket and storing them in the refrigerator.

6. Why is my ice so thick and difficult to fall from the ice tray? What should I do?

It may be that your ice making time is set for too long, or it may be that the temperature of your environment is very low. You can reduce the time to 0 or -6 by pressing the minus key on the touch panel.

7. Why does the ice cubes have a plastic smell?

The ice cube itself has no taste. If you feel there is a plastic smell, try to clean the inside of the machine with lemon water, then run a few cycles, and finally rinse with distilled water.

8. Why is there noise in the operation of my machine?

There is a faint sound when the machine is running. Closing the lid can reduce the noise. If the water pump makes a noise during use, it is recommended to turn off the machine first, and then turn on the machine after cleaning the filter in the water tank to observe whether or not the noise disappears.

9. Why is water leaking from my machine?

It may be that the PUA tube inside the machine fell off during transportation. You can remove the back cover of the machine and connect it by yourself. If you don't know how to operate, please contact the Euhomy team. We will give you a professional video to help you solve the problem.

10. Why is there water flowing but not making ice?

Please provide a video or picture and send it to us. The Euhomy team will assist you.

Contents

Safety precautions	02-04
Operation & Installation	05-16
Tips & Maintenance	17-21
Specifications	22-23
Warranty	24
Troubleshooting-support@euhomy.com	25

Safety Precautions



When using electrical appliances, basic safety precautions should be followed to **△** reduce the risk of fire, electric shock, and injury to persons or property. Read all the instructions before using any appliance:

- Use this appliance only for its intended purpose as described in this owners' manual.
- This ice-maker must be properly installed in accordance with the installation instructions before it is used.
- This unit must be positioned so that the plug is accessible. Do not run the cord over carpeting or other heat insulators. Do not cover the cord. Keep the cord away from areas with high traffic, and do not submerge in water. No other appliance should be plugged into the same outlet, and be sure that the plug is fully inserted into the receptacle.
- We do not recommend the use of an extension cord as it may overheat and cause a fire. If you must use an extension cord, use No.14AWG minimum size and rated no less than 1875 watts.
- If the supply cord is damaged, it must be replaced by the manufacturer or its service agent or a similarly qualified person in order to avoid a hazard.
- Disconnect the mains plug from the supply socket when not in use for a long term, where supply connection is via mains plug.
- Remove the power plug or disconnect from the mains before cleaning or servicing the appliance.
NOTE: *If for any reason this product requires service, we strongly recommend that a certified technician performs the service.*
- Never unplug your unit by pulling on the power cord. Always grasp the plug firmly and pull straight out from the outlet.
- Do not use your unit outdoors. Keep the unit away from direct sunlight and make sure that there is a space of at least 15 cm between the back of your unit and wall and keep the front free. Keep ventilation opening in the appliance enclosure or in the built-in structure, clear of obstruction.
- Do not tip over the unit as it may cause abnormal noisy and make the ice-cube size abnormal. And seriously, it may cause water leakage from the unit.
- If the unit is brought in from outside in the winter season, give it a few hours to warm up to room temperature before plugging it in.
- Do not use other liquid to make the ice-cube other than water.
- Do not clean your ice maker with flammable fluids. The fumes can create a fire hazard or explosion.

| Safety Precautions



Note:

- This appliance must be earthed. Use the proper power source according to the nameplate.
- Keep all ventilation openings, in the appliance enclosure or in the built-in structure, clear of obstruction.
- Do not damage the refrigerant circuit.
- This appliance is not intended for use by persons (including children) with reduced physical, sensory or mental capabilities, or lack of experience and knowledge, unless they have been given supervision or instruction concerning use of the appliance by a person responsible for their safety.
- Children should be supervised to ensure that they do not play with the appliance.
- This appliance must be earthed. And use the 110-120V/60Hz earthed power supply.
- Do not store explosive substances such as aerosol cans with a flammable propellant in this appliance.

Risk Of Fire or Explosion- Flammable Refrigerant Used

- Do Not Use Mechanical Devices To Defrost Ice Maker. Do Not Puncture Refrigerant Tubing.
- To Be Repaired Only By Trained Service Personnel. Do Not Puncture Refrigerant Tubing.
- Consult Repair Manual /Owner's Guide Before Attempting To Install or Service This Product. All Safety Precautions Must be Followed.
- Dispose Of Property In Accordance With Federal Or Local Regulations.
- Follow Handling Instructions Carefully.
- The ice maker should be installed in accordance with the safety standard for Refrigeration Systems, ASHRAE15. The ice maker shall not be installed in corridors or hallways of public buildings. If the unit needs maintenance, replacing should be done with like components and the servicing shall be done by factory authorized service personnel, so as to minimize the risk of possible ignition due to incorrect parts or improper service.
- This appliance must be earthed. Use the proper power source according to the nameplate.
- Keep ventilation openings, in the appliance enclosure or in the built-in structure, clear of obstruction.

Safety Precautions



Note:

- Do not damage the refrigerant circuit.
- This appliance is not intended for use by persons (including children) with reduced physical, sensory or mental capacities, or lack of experience and knowledge, unless they have been given supervision or instruction concerning the use of the appliance by a person responsible for their safety.
- Children should be supervised to ensure that they do not play with the appliance.
- This appliance must be earthed. Use a 110–120V/60Hz earthed power supply.
- Do not store explosive substances such as aerosol cans with a flammable propellant in this appliance.
- This appliance is intended to be used in household and similar applications such as staff kitchen areas in shops, offices and other working environments, e.g., farmhouses and by clients in hotels, motels and other residential type environments, e.g., bed and breakfast type environments, such as catering and similar non-retail applications.

ASSEMBLY AND PARTS

The wires in this mains lead are colored in accordance with the following code:
Green or Green with a strip

COLOR	WIRING
Yellow	Grounding
White	Neutral
Black	Live

To avoid a hazard due to instability of the appliance, it must be placed on an even or flat surface.

DIMENSIONS / CONNECTIONS

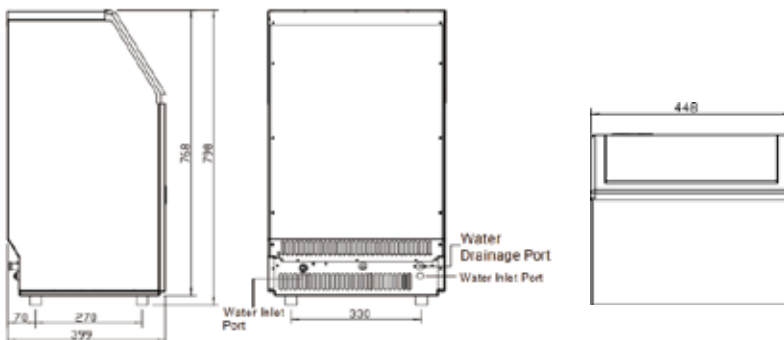

I Operation & Installation

MAIN UNIT CONSTRUCTION

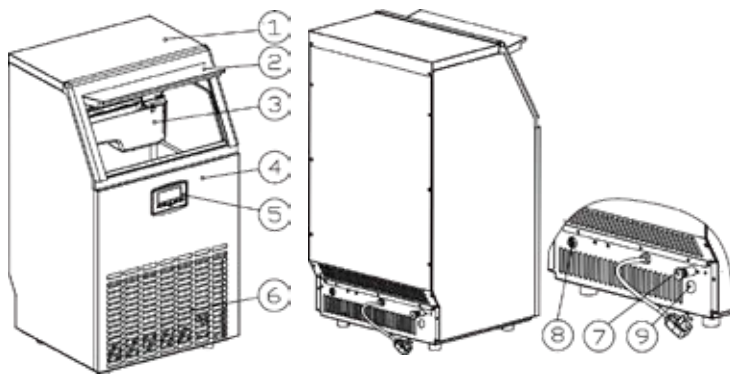

- 1.Top cover
- 2.Door for ice taking
- 3.Ice-making & its water tank assembly: Including ice-making evaporator, water tank, water pump and some detecting parts
- 4.Front panel
- 5.Operation panel
- 6.Air outlet: Must keep the air circulate smoothly. Hot air will blow out when unit running.
- 7.Water draining port: Normal plugged with the cap. When the water needs to be drained, unplug the cap.

And connect the white drain pipe.

- 8.Water inlet port for water supply: Use to connect the water supply pipe.

Accessory: 2 meters long and white color water drain pipe,
water quick connector of the water faucet,
ϕ6.35mm diameter and white color water supply pipe(3 meters long).

- 9.Water inlet port for bottled water supply: Use to no supply pipe, but has bottled water.

ICE-MAKING AND ITS WATER TANK PARTS

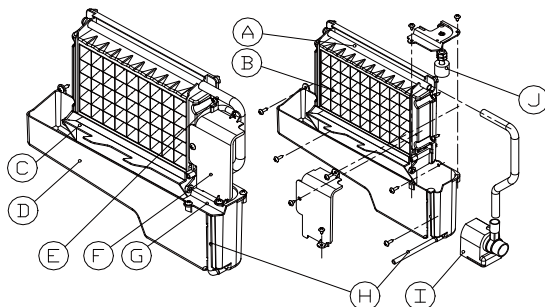

Operation & Installation

- A. Water dividing pipe: with nine little holes, water will flow from these little holes. If no water flows out, it can be disassembled and cleaned.
- B. Evaporator (ice-making module)
- C. Ice full detecting board: Use to detect if the inner cabinet is full of ice or not, and to check the ice-harvest process is over or not.
- D. Water tank:
- E. Water supplying pipe:
- F. Cover board on the right side of the evaporator:
- G. Water level switch installing plate:
- H. Water drainpipe of the water tank: when the unit is busy making ice, this pipe should be clamped in the slot of the water tank wall. When draining, this pipe should be pulled out.
- I. Water pump:
- J. Water level detecting switch.

OPERATION PANEL

A. LCD display window

1. Unit ON or OFF state symbol:

When the unit is turned off (standby mode), this symbol flashes, and when the unit is working, the symbol will keep lighting on.

2. Ambient temperature and ice-making countdown time display

3. Ice-making setting and Timer setting display

4. Error code: E1 means that the ambient temperature sensor is faulty E2 means that ice-making process is abnormal;

5. Light symbol: When this symbol displays, the LED light inside the cabinet will be on;

6. Water flowing and water absence symbol: If the arrow of this symbol flashes, means the water is flow in from main water supply. If the whole symbol keeps on, it means there is no water from main water supply.

7. Ice-full display: When the ice storing cabinet is full of ice cubes, this symbol will display, and the unit will stop the ice-making process.

8. Ice making and collecting display: When the ice cube symbol keeps rotating, it means the unit is making the ice. If the symbol flashes, it means the unit is during the ice collecting process.

9. Self-cleaning display.

B. "LED light" button: To turn on or turn off the internal LED light;

Note: Keep pressing this button for more than 5 seconds, it is to change the ambient temperature unit between Fahrenheit degree and Centigrade degree.

C. "Timer/Clean" button: Quickly press this button once to enter the Timer setting program. Press this button for more than 5 seconds to let the unit enter the Self-Cleaning program.

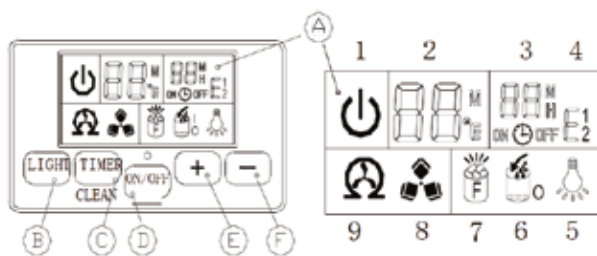

Operation & Installation

EXPLOSIVE DRAWINGS

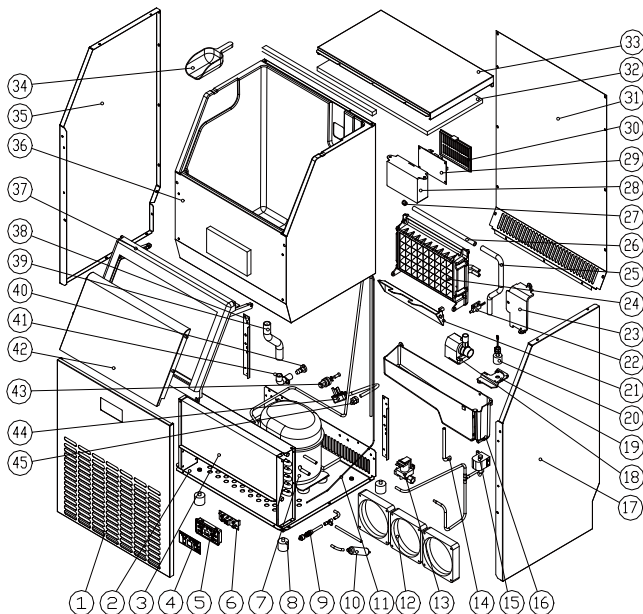

No.	Parts Name	Material	Qty.
1	Front panel	Stainless steel	1
2	Bottom plate	Zinc-plated steel board	1
3	Condenser	Copper tube and aluminum fin	1
4	Operation panel paper	PET	1
5	Operation panel PCB box	ABS	1
6	Operation panel PCB	Electrical and Electronic parts	1
7	Compressor	AC110-120V, 60Hz	1
8	Adjustable foot	ABS and bolts	4
9	Service valve	Copper	1
10	Dry filter	Copper	1
11	Capillary	Copper	1
12	DC fan	DC12V, Electrical parts	3
13	Water inlet valve	DC12V Electrical parts	1
14	Water drainage pipe of the water tank	Silicone pipe	1
15	Ice-harvesting Electro-magnetic valve	AC115V/60Hz, Electrical parts	1
16	Water tank	ABS	1
17	Right side plate	430 stainless steel, (Option)	1

Operation & Installation

18	Water circulation pump	AC110-120V, 60Hz, Electrical parts	1
19	Cover of the water tank	ABS	1
20	Water level detecting switch	DC5V, Electrical parts	1
21	Ice-full detecting plate	ABS	1
22	Magnetic control switch	DC5V, Electrical parts	4
23	Cover board on the right side of the evaporator	ABS	1
24	Evaporator and its frame	Copper plated with nickel, and ABS frame	1
25	Water supplying pipe	Silicone pipe	1
26	Water dividing pipe, with nine holes	ABS	1
27	Cap of the water dividing pipe	Silicone	1
28	Electrical PCB box	ABS, fire-retardant	1
29	Main control PCB	PCB, Electrical parts	1
30	Cover of the main control PCB	ABS, fire-retardant	1
31	Rear plate	Zinc-pated steel	1
32	Insulation sponge of the top cover	PE	1
33	Top cover	Stainless steel	1
34	Ice shovel	ABS	1
35	Left side plate	430 Stainless steel, (Option)	1
36	Foaming inner cabinet & Ice storing bin	HIPS and Cyclopentane foaming	1
37	Door frame	ABS	1
38	Back strength plate	Zinc-plated steel	1
39	Water outlet pipe of the inner cabinet	Silicone pipe	1
40	Water drainage cap	Rubber	1
41	Water drainage port	ABS	1
42	Door for ice taking	ABS	2
43	Water inlet port	PP	1
44	Power cord	Electrical parts	1
45	Clipper of the power cord	PP, fire-retardant	1
46	Wiring	Electrical parts	1

Operation & Installation

UNPACKING YOUR ICE MAKER

- Remove the exterior and interior packaging. Check if all the accessories, including the instruction manual, ice scoop, white water inlet pipe, 4 ways to 2 ways water quick connector and the water draining pipe, etc., are present. If any parts are missing, please contact our customer service.
- Remove the tape for fixing the door and inner cabinet, ice scoop, etc. Roughly clean the inner cabinet & ice scoop with a wet cloth.
- Put the ice maker on a level, flat surface, far from direct sunlight and other sources of heat (i.e., stove, furnace, radiator). Make sure that there is at least 20cm gap between the air outlet and the obstacles, and at least 5 cm between Left/Right side and the wall.
- Allow 4 hours for the refrigerant fluid to settle before plugging the ice maker in case the unit tipped over during shipping or transportation.
The appliance must be positioned so that the plug is accessible.

WARNING: connect to the potable water supply only. Only use drinking water.

UNPACKING YOUR ICE MAKER

- This unit is not for outdoor use. Keep the proper room temperature and inlet water temperature according to the above specification table. Otherwise, it will affect the ice making performance.
- This unit should not be placed near any heat resource.
- The unit should be located on a firm and level surface at normal countertop height.
- There must be at least 5cm clearance at rear side for connection and 25CM clearance in front to open the door and keep good air circulation.
- Do not put anything on the top of the ice maker

Installation clearance
top view (1:10) (mm)

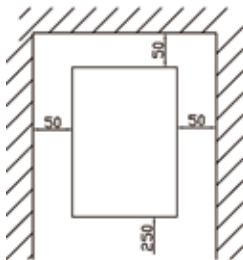

Side view (mm)

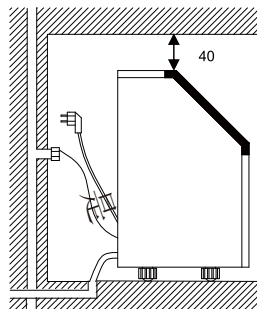

Operation & Installation

To ensure proper ventilation for your ice maker, the front of the unit must be completely unobstructed (at least 20CM free space). Allow at least 50 mm clearance at the back, and 50 mm at the top and sides for proper air circulation. The installation should allow the ice maker to be pulled forward for servicing if necessary.

When installing the ice maker under a counter, follow the recommended spacing dimensions as shown above.

Place electrical and water supplies and drain fixtures in the recommended locations as directed. Choose a well-ventilated area with temperatures above 50 Fahrenheit and below 90 Fahrenheit. This unit **MUST** be installed in an area protected from elements such as wind, rain, water spray or drips. The ice maker requires a continuous water supply with a pressure of 1–8 bar as required in above specification table. The temperature of the water feeding into the ice maker should be between 41 Fahrenheit and 77 Fahrenheit for optimal operation.

UNPACKING YOUR ICE MAKER



Note: This unit must be earthed

Electrical Shock Hazard

Plug into a grounding wall outlet. Never remove the ground prong. Use separate power supply or receptacle. Never use an adapter.

Never use an extension cord. Failure to follow these instructions may result in fire, electrical shock or even death.

Before you move your ice maker into its final position, it is important to make sure you have the proper electrical connection.

It is recommended that a separate circuit, serving only your ice maker, be provided. Use receptacles that cannot be turned off by a switch or pull chain. If the supply cord or plug needs to be replaced, it should be done by a qualified service engineer.

This appliance requires a standard 110–120Volt, 60Hz electrical outlet with good grounding means.



Note: Recommended grounding method

For your personal safety, this appliance must be properly grounded. This appliance is equipped with a power supply cord having a grounding plug. To minimize possible shock hazard, the cord must be plugged into a mating grounding-type wall receptacle, grounded in accordance with the National Electrical Code and local codes and ordinances. If a mating wall receptacle is not available, it is the personal responsibility of the customer to have a properly grounding wall receptacle installed by a qualified electrician.

Operation & Installation

CLEANING YOUR ICE MAKER BEFORE USING FOR THE FIRST TIME

Before using your ice maker, it is strongly recommended to clean it thoroughly.

- Open the ice collecting door.
- Clean with diluted detergent, warm water and a soft cloth.
- Repeatedly clean the water contacting inner parts, you can pull the Water drainpipe of the water tank indicating "IT" in above illustration to drain the cleaned water in the water tank. To clean the inner ice-storing cabinet till all the inner parts are clean, drain out all of the cleaned water from the water drain port located at unit back indicating "7" in above illustration. Now reinstall the water drainpipe of the water tank and the cap of the unit water drain port, otherwise the unit will not make the ice normally. We suggest that you discard the ice-cube made by the first ice making cycle after cleaning.
- The outside of the ice maker should be cleaned regularly with a mild detergent solution and warm water.
- Dry the interior and exterior with a clean, soft cloth.

UNPACKING YOUR ICE MAKER

Important: Be sure to use the new hose-sets supplied with the appliance to connect to water mains. Old hose sets should not be reused.

• Option#1 Connect the water supplying hose to the unit

Step 1: First remove the clipper on the water inlet port for water supply (indicated in the following illustration "A") located at unit back.

Step 2: Insert the one end of the white water hose into the water inlet port, and push inward completely, and install back the clipper, then the water hose connection is completed.

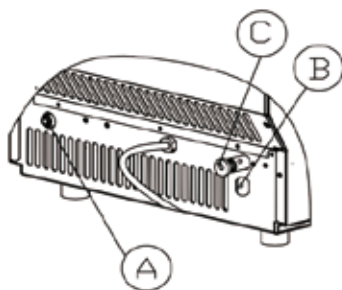

PIC.1

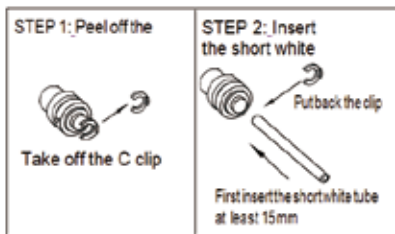

• Step 3: Connect the water hose to the water faucet of the water main supply system

First, install the supplied water quick-connector to the water faucet by screw thread; Second, remove the clipper from the water quick-connector, and insert the another end of the water hose into this quick-connector port completely. Next install back the clipper, and this step is completed.

Note: The water faucet should be supplied by the customer himself.

Operation & Installation

- Important: The water pressure of main water supply system must be 0.04–0.6 MPa at least.

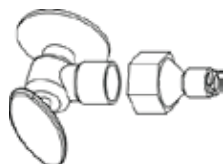

STEP 1: Quick-connector and the water faucet

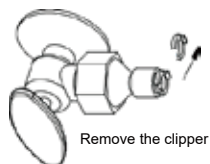

STEP 2: Screw the quick-connector on the water faucet by the screw thread, and remove the clipper

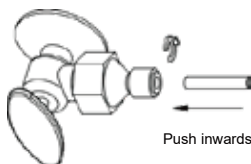

STEP 3: Insert the water hose completely

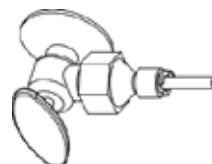

STEP 4: Install back the clipper

- Option#2 Connect the water tube to use bottle water, use for part B

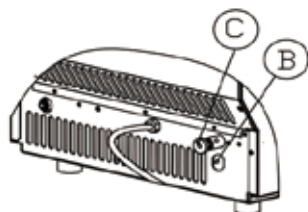

<p>STEP 1: Peel off the</p> <p>Take off the C clip</p>	<p>STEP 2: Insert the short white tube</p> <p>Put back the clip</p> <p>First insert the short white tube at least 15mm</p>	<p>STEP 3: Insert the long clear silicon tube, put the other end to the water bottle</p>
--	--	--

Connecting the water drain pipe

Pull out the water drainage cap with black color (indicated ○C in above illustration), then connect the white drainage pipe included in accessory. Now connect the other end of this drainage to the main water drainage pipeline.

OPERATION THE ICE-MAKING PROCESS

Ice making program is explained in following chart:

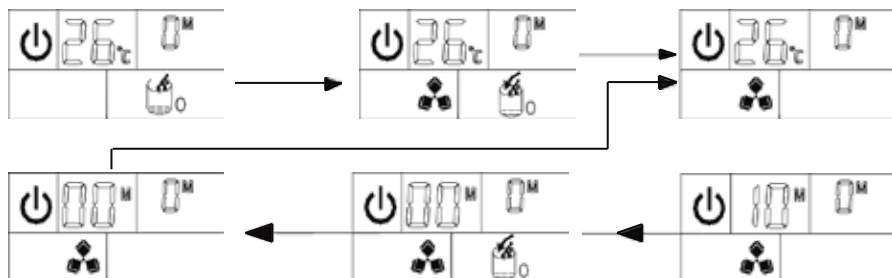

Operation & Installation

Step 1: Standby state

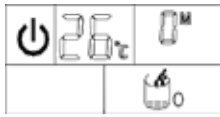

Press ON/OFF button to turn on the unit

Step 2: The arrow flashes, and water flows in the unit

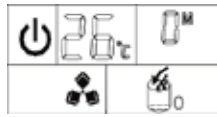

Step 3: Start to make ice, and ice-cube symbol rotates.

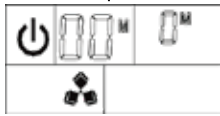
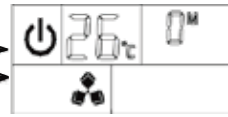



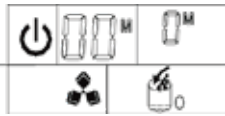

Step 6: During ice-collection, the water-flowing process finished to start to make ice-cube again.

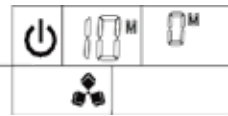

Step 5: Ice-collection starts and the ice-cube symbol flashes; At the same time the arrow flashes and water flows into the water tank.



Step 4: Display the countdown time of one ice-making process

-  Automatic water supplying symbol  Arrow of symbol flashes and this means the water is flowing into the water tank  If this whole symbol keeps displaying, it means there is no main water supplying at present.
-  Ice-cube symbol, when it rotates, it means the unit is making ice cubes; and it flashes, it means the unit is in ice collecting process.

F Fahrenheit (ambient temperature) H unit of hour (setting the timer)
M unit of minute (ice-making setting and countdown time)

1. After completing the connection of the main water supplying hose with the unit, plug in the main power supply plug. Then press the "ON/OFF" button on the control panel to begin the ice making cycle. The unit ON/OFF state symbol will keep lighting on, and the left number in the LCD display window displays the present ambient temperature. The right number displays the present ice-making setting, and the ice-cube symbol rotates. When the left number starts flash, then the number means the countdown time to complete one ice making cycle.
 2. Each ice making cycle will last about 11 to 20 minutes, depending on the ambient temperature and the water temperature. And for the first time, according to the initial water temperature, the ice-making process time will be a little longer.
 3. When the ice-making process is over, then switch to ice-collecting process. During the ice-collecting process, the ICE cube symbol change rotating to flash. At same time, the arrow on the manual filling water symbol will start to flash, and the water will flow into the water tank again till the floating ball of water level switch rises up to the highest position. The water will stop flowing and the whole manual filling water symbol will disappear.
- When the ice-collection process is complete, the Ice-full detecting plate will rotate downward once, and then recover to the original position and enter to the next ice-making process.
- If the Ice-full detecting plate is pressed by ice blocks after rotation and cannot be restored to its original position, it means that the ice storage bin is full of ice blocks and the ice making is automatically stopped.

Operation & Installation

4. When the "ICE-FULL" symbol display is on, the unit stops running. And if you remove the ice cubes, the unit will start to make ice cubes again. But it will restart only after a 3 minute interval of compressor running.

5. During the ice-making process, press the "+" or "-" button to adjust the ice-making process duration period length, and then to change the thickness of the ice cube. Press the "+" or "-" button, and the right digit will flash. The default setting is zero, 1 minute will be add or decreased to each ice making process per each pressing of "+" or "-" button. After 5 seconds of setting, the new setting will be remembered by the system.

6. The bad water quality will cause bad quality ice cubes, and reduce the transparency of the ice cube.

• Automatic self-cleaning program

Start the self-cleaning program: After connecting all of the water pipe, plug on the main power supply plug, then press "TIMER /CLEAN" button on control panel for more than 5 seconds, to enter the Self-Cleaning program. The "🔄" symbol will always be on during this period, the left digit will indicate the left time. The total duration time is 20 minutes for one self-cleaning program.

Cancel the self-cleaning program: It takes about 20 minutes to complete one self-cleaning program. When the program is over, the system will be in standby mode automatically. You can press the "ON/OFF" button on control panel to cancel the self-cleaning program by force.

• Timer setting operation

Delay time range: 1-24 hours, Default time: 1 hour

How to set the ON-Timer: When the unit is in standby mode, press the "TIMER/CLEAN" button to set the ON-Timer. The "🕒" symbol will turn on, the number "1" above the symbol will flash to display the set delay time. During the number flashing, press the "+", "-" button to change the delay time of the timer, 1 hour increasing or decreasing per each pressing of "+" or "-" button. Five seconds after setting it, your desired setting will be remembered.

How to cancel the ON-Timer: Press the "TIMER/TIMER" button, the number above the "🕒" symbol will flash to display the present delay time of your ON-Timer. Press this button once again to cancel the Timer setting, and the "🕒" symbol and the number will disappear. And the second easy way to cancel the ON-Timer is to press the "ON/OFF" button, it will cancel the ON-TIMER setting by force.

How to set the OFF-Timer: When the unit is working, press the "TIMER/CLEAN" button to set the OFF-Timer. The "🕒 OFF" symbol will turn on, and the number "1" above the symbol will flash to display the setting delay time. During the number flashing, press "+", "-" button to change the delay time of the timer, 1 hour will be increasing or decreasing per each pressing of "+" or "-" button. Five seconds after setting, your desired setting will be remembered.

How to cancel the OFF-Timer: Press the "TIMER/TIMER" button, and the number above the "🕒 OFF" symbol will flash to display the present delay time of your OFF-Timer. Press this button once again to cancel the Timer setting. The "🕒 OFF" and the above number will disappear. Another easy way to cancel the OFF-Timer is to press the "ON/OFF" button, as it will cancel the ON-TIMER setting by force, also will turn off the unit.

Operation & Installation

Internal LED light operation

When the unit is plugged in, press the "LIGHT" button on the operation panel once to lighten the LED light inside the ice bin and the "  " symbol on the LCD display window will also be on.

Press this button once again, the LED light and the "  " symbol will be off at same time.

NOTE: If you press the "LIGHT" button for more than 5 seconds, the ambient can be changed between Centigrade degree and Fahrenheit degree (°C and °F) .

ERROR code of unit breakdown

When the unit is broken, the error code will display in the left side of LCD display window.

E1 means the sensor of ambient temperature is malfunctioning.

E2 means that ice making program is abnormal, including too big ice-cubes, no ice falling off, or not making ice cubes, etc.

NOTE: During the ice cube making process, press the "ON/OFF" button for more than 5 seconds, and the unit will jump to the ice-collecting process . After the ice collecting process is completed, the unit will recover to ice making process.

Water Drainage

Make sure the water drainage pipe has correctly connected at the unit back first.

A.You can drain the water in ice bin through the white drainage pipe connected on the back drainage port. Make sure not to set the white drainage pipe too high.

B.For the water in the water tank, you can pull out the silicone pipe on the right side of the water tank indicating "H" in above illustration to drain out the cleaned water in the water tank, till the silicone pipe extends completely, the water can flow out into the ice bin. Then the water can be drained out through the water drain port at unit back.

Reminding: Clean the water tank frequently, as it can improve the ice-cube quality and the unit and its water circulation pump can work much longer.

Normal Sounds

Your new ice maker may make sounds that are not familiar to you. Most of the new sounds are normal. Hard surfaces like the floor, walls and cabinets can make the sounds seem louder than they actually are. The following describes the kinds of sounds that might be new to you and what may be making them.

- You will hear a swooshing sound when the control valve opens to let water flow into the water tank for each ice-making cycle.
- Rattling noises may come from the flow of the refrigerant or the water line. Items stored on top of the ice maker can also make noises.
- The high-efficiency compressor may make a pulsating or high-pitched sound.
- Water running from the water tank to the evaporator plate may make a splashing sound.

Operation & Installation

Preparing the Ice Maker for Long Storage

If the ice maker is not going to be used for a long time, or is to be moved to another place, it will be necessary to drain out all of the water in the system.

- Allow all of the ice cubes have been ejected from the evaporator of ice maker.
- Turn off the unit, and unplug the power cord.
- Shut off the water supply at the main water supply.
- Disconnect the water supply hose from the water inlet valve.
- Pull out the water drain pipe of the water tank indicating “H” in above illustration to drain out the water in the water tank. When all of the water has been drained out, reinstall back the water drain pipe of the water tank.
- Then drain out all of the water from the water drain port located at unit back indicating “7” in above illustration.
- Disconnect the water drain pipe to the main drain pipeline or floor drain, and plug in the drain cap again.
- Drop the door open to allow for circulation and prevent mold and mildew.
- Leave water supply hose and power cord disconnected until ready to reuse.
- Dry the interior & wipe the outside of the unit.
- Put a plastic bag over the unit to keep out dust & dirty.

CLEANING & MAINTENANCE

WARNING: Before carrying out any cleaning or maintenance operations, unplug the ice maker from the main power supply electricity. (EXCEPTION: Ice maker self-cleaning program).

Do not use any alcohol or fumes for cleaning/sanitization of the ice maker. It may cause cracks on the plastic parts.

Ask a trained service person to check and clean the condenser at least once a year, in order to let the unit work properly.

This appliance must be cleaned by use of a water jet.

CAUTION

If the ice maker has been left unused for a long time, before the next use it must be thoroughly cleaned. Follow instructions provided for cleaning or use of sanitizing solution. Do not leave any solution inside the ice maker after cleaning.

Periodic cleaning and proper maintenance will ensure efficiency, top performance, hygienic, and long life. The maintenance intervals listed are based on normal conditions. You may want to shorten the intervals if you have pets, or if the unit is used outdoors, or if there are other special considerations.

I Tips & Maintenance

PREPARING THE ICE MAKER FOR LONG STORAGE

If the ice maker will not be used for a long time, or if it is to be moved to another place, it will be necessary to drain out all of the water in the system.

- Allow all the ice cubes to be ejected from the evaporator of ice maker.
- Turn off the unit, and unplug the power cord.
- Shut off the water supply at the main water supply.
- Disconnect the water supply hose from the water inlet valve.
- Pull out the water drainpipe of the water tank indicating "H" in above illustration to drain out the water in the water tank. When all of the water has been drained out, to reinstall back the water drainpipe of the water tank.
- Then drain out all of the water from the water drain port located at unit back indicating "7" in above illustration.
- Disconnect the water drainpipe to the main drain pipeline or floor drain, and then plug in the drain cap again.
- Drop the door open to allow for circulation and prevent mold and mildew.
- Leave water supply hose and power cord disconnected until ready to reuse.
- Dry the interior & wipe the outside of the unit.
- Put a plastic bag on the unit to keep out dust and dirt.

Before carrying out any cleaning or maintenance operations, unplug the ice maker from the main power supply electricity. (EXCEPTION: ice maker has a self-cleaning program).

Do not use any alcohol or fumes for cleaning/sanitization of the ice maker. It may cause cracks on the plastic parts.

Ask a trained service person to check and clean the condenser at least once a year, in order to let the unit work properly.

This appliance must be cleaned by using a water jet.

If the ice maker has been left unused for a long time, it must be thoroughly cleaned before the next use. Follow carefully any instructions provided for cleaning or use of sanitizing solution.

Do not leave any solution inside the ice maker after cleaning.

Periodic cleaning and proper maintenance will ensure efficiency, top performance, hygienic, and longevity. The maintenance intervals listed are based on normal conditions. You may want to shorten the intervals if you have pets, or the unit is used outdoors, or there are other special considerations.

What shouldn't be done?

Never keep anything in the ice storage bin that is not ice: objects like wine and beer bottles are not only unsanitary, but its labels may slip off and obstruct the drainpipe.

EXTERIOR CLEANING

The door and cabinet may be cleaned with a mild detergent and warm water solution such as 28g of dish washing liquid mixed with 7.5L of warm water. Do not use solvent-based or abrasive cleaners. Use a soft sponge and rinse with clean water. Wipe with a soft, clean towel to prevent water spotting.

Stainless steel models can discolor when exposed to chlorine gas and should be cleaned. Clean stainless steel models with a mild detergent and warm water solution and a damp, soft cloth. Never use abrasive cleaning agents.

Tips & Maintenance

NOTICE: Stainless steel models exposed to chlorine gas and moisture, such as in areas with spas or swimming pools, may have some discoloration of stainless steel. Discoloration from chlorine gas is normal.

INTERIOR CLEANING

For Ice Storage Bin

The ice storage bin should be sanitized occasionally. Clean the bin before the ice maker is used for the first time and reused after stopping for an extended period of time. It is usually convenient to sanitize the bin after the ice making system has been cleaned, and the storage bin is empty.

- Disconnect power to the unit.
- Open the door and with a clean cloth, wipe down the interior with a sanitizing solution made of 28g of household bleach or chlorine and 7.5L of hot water (95T to 115°F).
- Rinse thoroughly with clear water. The wastewater will be drained out through the drainpipe.
- Reconnect power to the unit

The ice scoop should be washed regularly. Wash it just like any other food container.

DO NOT use solvent cleaning agents or abrasives on the interior. These cleaners may transmit taste to the ice cubes, or damage or discolor the interior.

ICE MAKING PARTS CLEANING

During the using, periodically to clean these main system of your ice-maker.

- Repeat the above step to clean the water tank and other inner parts of the unit especially, to the water dividing pipe on the evaporator, when the compressor and the water pump run normally. However, if there is no water flowing out from the water dividing pipe or the water flowing is very small, please discharge this water dividing pipe to clean carefully. Clean each little hole on the water dividing pipe displayed in the following illustration, and make sure each hole is not clogged by something, then install back to the original location.
- When there are ice cubes on the surface of the evaporator, but can't fall down easily. Never use the mechanical substance to remove it by force. Only press the "ON/OFF" button for more than 5 seconds and the unit will enter the ice melting process, after some while, the big ice-cubes will fall down, then turn off the unit and unplug the power cord to clean the surface of the evaporator.

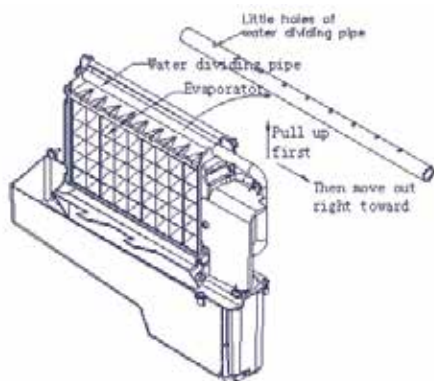

I Tips & Maintenance

- For the water tank and ice-full detecting plate

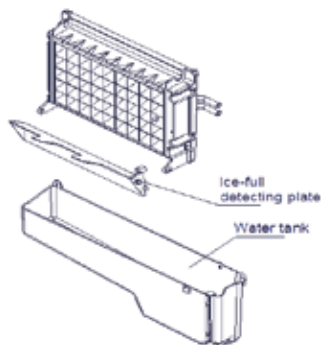

- Also, the water tank and the ice-full detecting plate is very important to keep your ice cube hygienic. Put a mixture of neutral cleaner & water into a clean water jet, and then spray to all the inner surface of tank & the ice detecting plate. Wipe these surfaces with a clean cloth. And then, spray the surfaces with clean water, wiping with a dry clean cloth. Then drain out the cleaned water in the water tank by pulling out the water drainpipe of the water tank indicating "H" in above illustration. When all of the cleaned water has been drained out, reinstall the water drainpipe of the water tank.

 After cleaning the interior parts and install back to its respective position, and return machine to work, discard first batch of ice.

Ice Making Assembly System Cleaning by Using Nu-Calgon Nickle Safe Ice-machine Cleaner

Minerals that are removed from water during the freezing cycle will eventually form a hard scaly deposit in the water system. Cleaning the system regularly helps to remove the mineral scale buildup. How often you need to clean the system all depends upon how hard your water is. With hard water of 4 to 5 grains/liter, you may need to clean the system as often as every 6 months.

- Turn off the ice maker. Keep the ice maker connected to the water supply and drainpipe. But shut off the water faucet of main water supply.
- Open the door and scoop out all of the ice cubes. Either discard them or save them in an ice chest or cooler.
- Preparing the cleaning solution. Please mix the Nu-Calgon Nickle Safe Ice Machine Cleaner with water to make the cleaning solution.

 **WARNING:** Wear rubber gloves and safety goggles (and/or face shield) when handling Ice Machine Cleaner or sanitizer.

Use a plastic or stainless container with more than 4 liters capacity, and mix 300 ml Nu-Calgon Nickle Safe Ice-machine Cleaner with 2.8 liters warm water about 120T-140T, then divide them for 2 shares equally in 2 cups. It is better to keep the temperature of each cup of the cleaning solution.

I Tips & Maintenance

- Check to be sure that the water drainpipe of the water tank has been installed properly in the slot of the tank wall. Then pour one cup of Nickel-Safe Ice Maker Cleaning Solution into the water tank. Wait about for 5 minutes.
- Turn on the power to the ice maker, and press "TIMER CLEAN" button on the control panel for more than 5 seconds to enter the self-cleaning program. As explained above, the water pump runs for 8 minutes and stops for 3 minutes, completes one cycle, and then another. The total duration time is 30 minutes for one self-cleaning program. The "CLEAN" light will always be on during this period, and the digit window will indicate the remaining time.
- After 30 minutes of one self-cleaning program completing, pull out the drainpipe of the water tank, drain the cleaning solution down to the lower ice storage bin. Shake the unit slightly to drain out all of the cleaning solution. Then install the drainpipe to the slot of the water tank again.
- Repeat steps 4-6 to clean the ice making assembly system again.

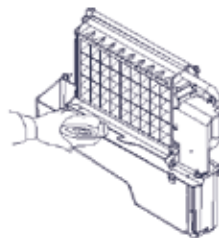

WARNING: The ice machine cleaner contains acids. DO NOT use or mix with any other solvent-based cleaner products. Use rubber gloves to protect hands. Carefully read the material safety instructions on the container of the ice machine cleaner.

- Then open the water faucet of the main water supply and let the water flow in the unit. Press the "TIMER CLEAN" button on control panel for more than 5 seconds to enter the self-cleaning program. As explained above, the water pump runs for 8 minutes and stops for 3 minutes, completes another cycle, and then another one. The total duration time is 30 minutes for one self-cleaning program. During this process, the "CLEAN" light will always be on during this period, and the digit window will indicate the left time. Through this process, it will rinse the water dividing pipe, evaporator, water pump, silicone pipe, and water tank, etc.
- When the self-cleaning program is complete, pull out the drainpipe of the water tank, drain the cleaning solution down to the lower ice storage bin, also shake the unit slightly to drain out all of the water completely. Then install back the drainpipe to the water tank slot tightly.
- Repeat step 8-9 again for 2 times.
- Follow the above program to clean the ice storage bin.
- When this special cleaning program finished, you can return to the regular ice making mode. We suggest that you discard the first batch of ice cube.

INTERIOR CLEANING

• DAILY CLEANING

The ice shovel, door and the water dividing pipe should be cleaned each day. At the end of every day, rinse the ice shovel and wipe both sides of the door with a clean cloth.

I Tips & Maintenance

- **SEMI-MONTHLY CLEANING**

The ice shovel, ice bin, water tank, the ice-full detecting plate and the surface of the evaporator are to be cleaned twice a month according to the interior cleaning program.

- **SEMI-ANNUAL CLEANING**

All the components & surfaces exposed to water or ice cubes, like ice storage bin, water tank, door, evaporator, water pump, silicone tube, water dividing pipe, etc. should be cleaned **by Using Nu-Calgon Nickle Safe Ice-machine Cleaner** every 6 months. They should be cleaned by the serviceman according to ice making assembly system cleaning program.

CORRECT DISPOSAL OF THIS PRODUCT



This marking indicates that this product should not be disposed with other household waste throughout the EU. To prevent possible harm to the environment or human health from uncontrolled waste disposal, recycle it responsibly to promote the sustainable reuse of material resources. To return your used device, please use the return and collection system or contact the retailer where the product was purchased. They can take this product for environmentally safe recycling

Specifications

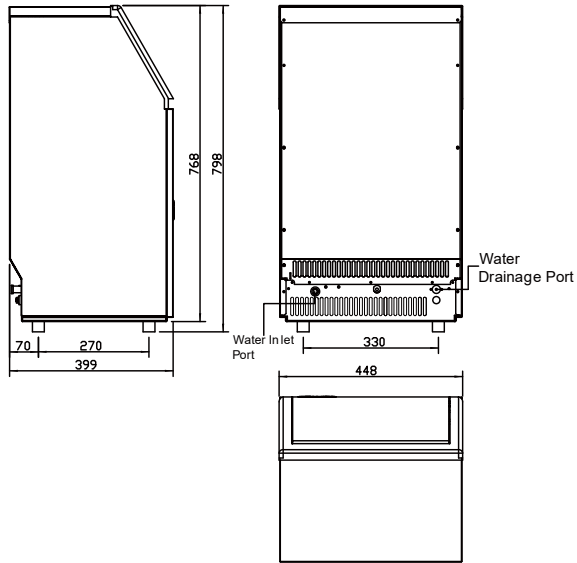

CORRECT DISPOSAL OF THIS PRODUCT

SKU	IM-02P
POWER SUPPLY VOLTAGE	1 Phase, 110-120/60HZ
CLAIMATE CLASS	104TC
ELECTRICAL PROTECTION CLASS	I
ICE MAKING RATING (Amps)	2.2Amp
ICE HARVEST RATING (Amps)	2.5Amp
ICE MAKING CAPACITY (KG/24H)	45kg/24Hour*
REFRIGERANT CHARGE	R290 3.35Oz/95g
VESICANT	CsHio
UNIT DIMENSIONS (W X D X H)	448x400x798
WATER CONSUMPTION(M24H)	50L
MAX ICE STORAGE CARACITY(KG)	15Kg
ACCESSORIES	SHOVEL, INSTALLATION KITS
CONNECTION	POWER CORD--18AWG WATER SUPPLY--6.35mm diameter DRAIN016 SYLPHON BELLOWSS(REAR)
RUNNING CONDITIONS	ROOM TEMP 50-110 Fahrenheit WATER SUPPLY TEMP 41-95 Fahrenheit WATER SUPPLY PRESSURE 0.04-0.6 MPa

NOTE *: TESTED AT 70 Fahrenheit ROOM TEMPERATURE AND 50 Fahrenheit WATER TEMPERATURE.

I Specifications

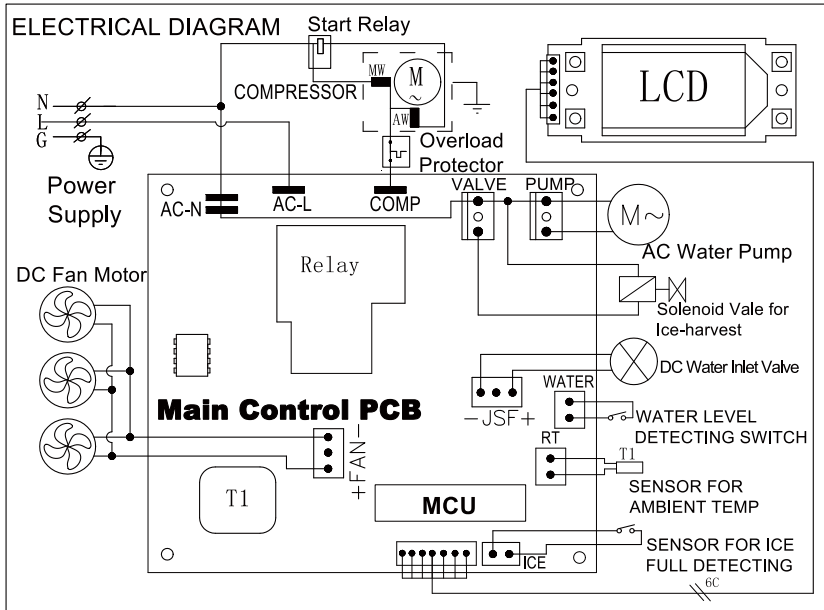

WIRING DIAGRAM

NORMAL SOUNDS

Your new ice maker may make sounds that are not familiar to you. Most of the new sounds are normal. Hard surfaces like the floor, walls and cabinets can make the sounds seem louder than they actually are. The following describes the kind of sounds that might be new to you and what may be causing them.

- You will hear a swooshing sound when the water valve opens to fill the water tank for each cycle.
- Rattling noises may come from the flow of the refrigerant or the water line. Items stored on top of the ice maker can also make noises.
- The high-efficiency compressor may make a pulsating or high-pitched sound.
- Water running from the water tank to the evaporator plate may make a splashing sound.
- Water running from the evaporator to the water tank may make a splashing sound.
- As each cycle ends, you may hear a gurgling sound due to the refrigerant flowing in your ice maker.
- You may hear air being forced over the condenser by the condenser fan. During the harvest cycle, you may hear the sound of ice cubes falling into the ice storage bin.
- When you first start the ice maker, you may hear water running continuously. The ice maker is programmed to run a rinse cycle before it begins to make ice.

Warranty

Euhomy offers a limited 1-year warranty ("warranty period") on all of our products purchased new and unused from Euhomy company, with an original proof of purchase and where a defect has arisen, wholly or substantially, as a result of faulty manufacture, parts or workmanship during the warranty period. The warranty does not apply where damage is caused by other factors, including without limitation:

- (a) normal wear and tear;
- (b) abuse, mishandling, accident, or failure to follow operating instructions;
- (c) exposure to liquid or infiltration of foreign particles;
- (d) servicing or modifications of the product other than by Euhomy;
- (e) commercial or non-household use.

The Euhomy warranty covers all costs related to restoring the proven defective product through repair or replacement of any defective part and necessary labor so that it conforms to its original specifications. A replacement product may be provided instead of repairing a defective product. Euhomy's exclusive obligation under this warranty is limited to such repair or replacement. A receipt indicating the purchase date is required for any claim, so please keep all receipts in a safe place. Although greatly appreciated, the product registration is not required to activate any warranty and product registration does not eliminate the need for the original proof of purchase. The warranty becomes void if attempts at repair are made by non-authorized third parties and/or if spare parts, other than those provided by Euhomy.

You may also arrange for service after the warranty expires at an additional cost. These are our general terms for warranty service, but we always urge our customers to reach out to us with any issue, regardless of warranty terms. If you have an issue with a Euhomy product, please contact us (support@euhomy.com), and we will do our best to resolve it for you.

Problem	Possible Cause	Solution
 "indicator is on.	No water supply.	Check the main water supply pressure or check the water supply hose is blocked or not, adding the water pressure or cleaning the hose necessary.
	Floating ball of the water level detecting switch is blocked, can't be raised up.	Clean the water tank and the water level detecting switch.
	Water flows out from the water tank.	Place the unit on the level position, not on the slope.
	Water flows out from the water drainpipe of the water tank.	Pull out the pipe and install back to the slot of the water tank properly.
The unit start to enter the ice making process, but no water flowing in the unit, and the  indicator flashes.	Water supplying hose breakdown, or water flows in very slowly.	Check the main water supply pressure or check the water supply hose is blocked or not, adding the water pressure or cleaning the hose necessary.
Water pump is working, but no water flow out from the water dividing pipe.	The little holes on the water dividing pipe is blocked.	Clean these little holes.
The transparency of the ice cube is not very good.	Water quality is bad.	Change the water supply, or use the water filter to soften or filter the water.
Ice cube shape is irregular.	Water quality is not good, or the water tank is very dirty.	Water supplying hose breakdown, or water flows in very slowly.
	The little holes on the water dividing pipe is some blocked.	The little holes on the water dividing pipe is blocked.
Ice cube is very thin.	Ambient temperature is too high.	Water quality is bad.
	Air circulation around the unit is not good.	Water quality is bad.
Ice cube is too thick.	Ambient temperature is too low.	Reduce the time of each ice making cycle.
 "indicator is on.	The ice storage bin is full of ice cubes.	Take out some ice cubes.
Ice making cycle is normal, but there is no ice cube produced.	The temperature of Ambient, or water in water tank is too high.	Move to the place with temperature lower than 90 Fahrenheit, centigrade, and change to the low temperature water.
	Refrigerant leakage.	Need the technical serviceman to maintain.
	Cooling system tube is clogged.	Needs a technical service person for maintenance.

EUHOMY

Refresh Every Moment!



Email: support@euhomy.com



Facebook: [@Euhomy.Official](https://www.facebook.com/Euhomy.Official)