

# EXCEL

## 240V

### OPERATING INSTRUCTIONS

SKU:30961

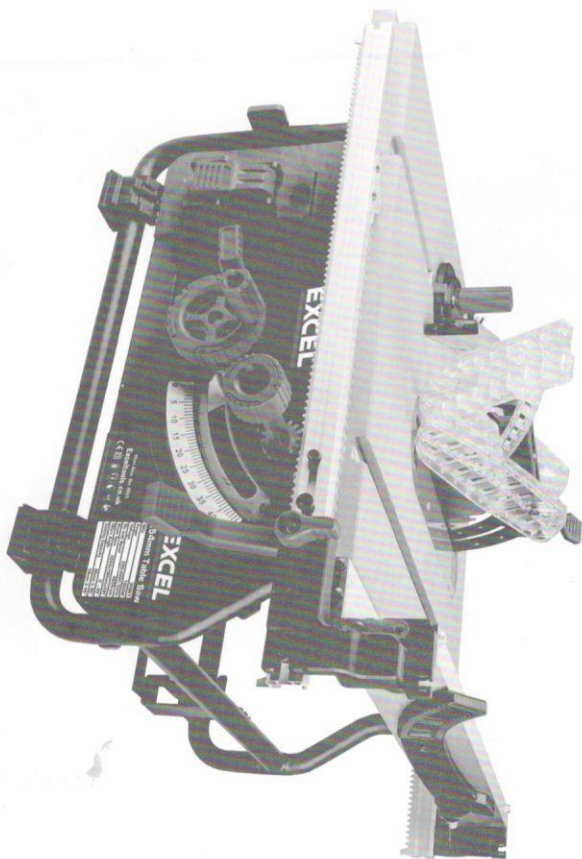

## 254MM

## TABLE SAW 1800W

# EXCEL

CONTACT US:

Tools4Trade Ltd.

6 Fitzhamon Court, Bradwell Wolverton,  
Milton Keynes, MK12 6LB

PHONE:  
01908 969966

Email:  
sales@tools4trade.co.uk

Danger! Read all safety regulations and instructions.  
Keep all safety regulations and instructions in a safe place for future use.



EXCELTOOLS.CO.UK

EXCELTOOLS.CO.UK

Fig. 1

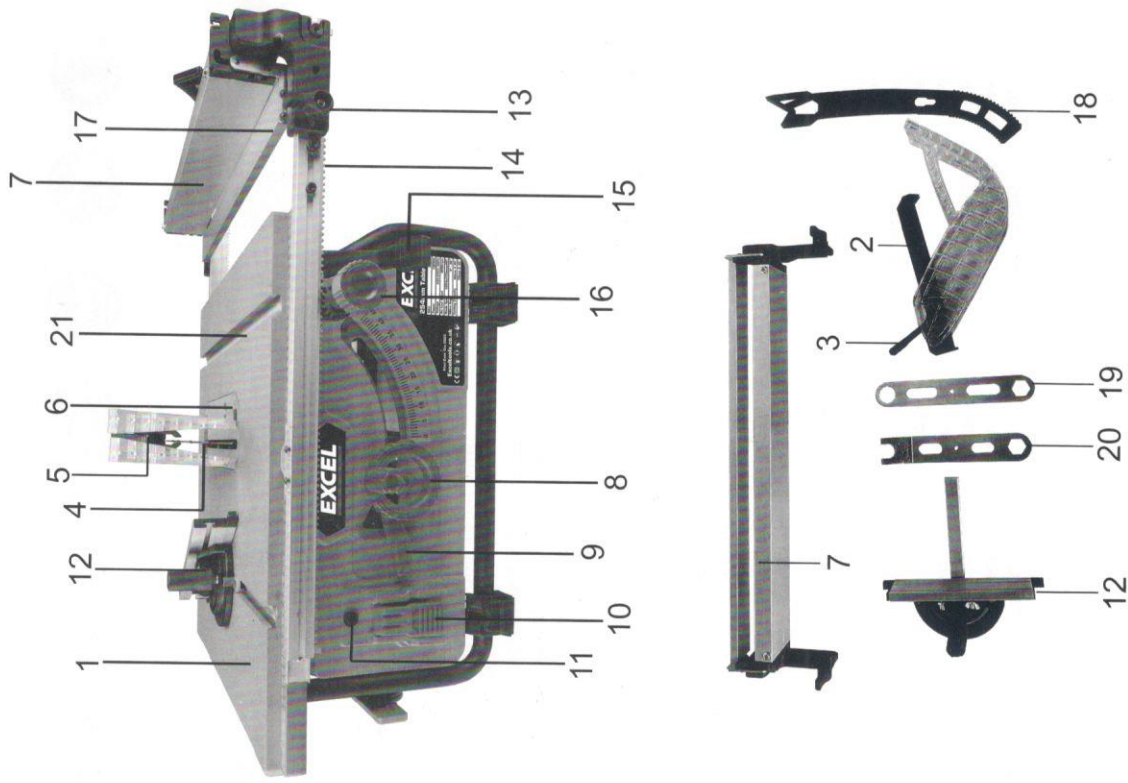
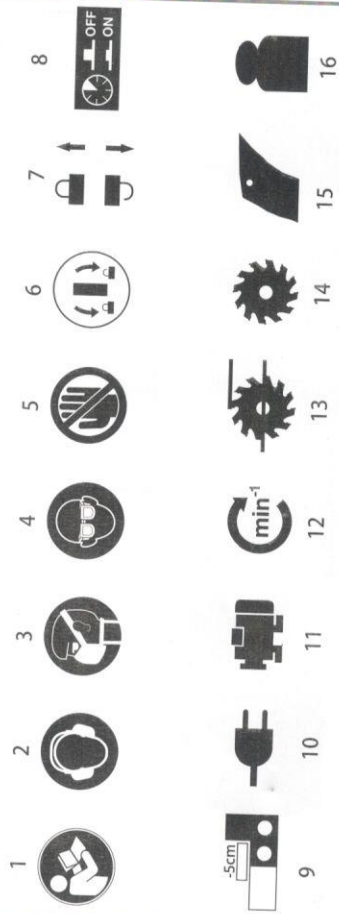

Fig. 2



**Danger!**

When using the equipment, a few safety precautions must be observed to avoid injuries and damage. Please read the complete operating instructions and safety regulations with due care. Keep this manual in a safe place, so that the information is available at all times. If you give the equipment to any other person, hand over these operating instructions and safety regulations as well. We cannot accept any liability for damage or accidents which arise due to a failure to follow these instructions and the safety instructions.

**Explanation of the symbols used (see Fig. 2).**

1. **Danger!** - Read the operating instructions to reduce the risk of injury.
2. **Caution!** Wear ear-muffs. The impact of noise can cause damage to hearing.
3. **Caution!** Wear a breathing mask. Dust which is injurious to health can be generated when working on wood and other materials. Never use the device to work on any materials containing asbestos!
4. **Caution!** Wear safety goggles. Sparks generated during working or splinters, chips and dust emitted by the device can cause loss of sight.
5. **Caution!** Risk of injury! Do not reach into the running saw blade.
6. Using the supplied ring wrench, turn the disk clockwise to release the table insert. Turn the disk counter-clockwise to secure the table insert against falling out.

7. To adjust the blade angle, swing the locking lever downwards. To lock the blade angle, swing the locking lever upwards.
8. Press in the overload cut-out in order to release the On/Off switch again.
9. When you fold the stop rail over the saw table for narrow cutting widths, this will reduce the actual cutting width by 5 cm compared to the cutting width reading.
10. Conditions of the mains connection
11. Power rating
12. Speed
13. Cutting height at 90° and 45° blade angle
14. Blade dimensions
15. Thickness of the splitter
16. Weight

**1. Safety regulations**

The corresponding safety information can be found in the enclosed booklet.

**WARNING!**

Read all safety warnings, instructions, illustrations and specifications provided with this power tool. Failure to follow all instructions listed below may result in electric shock, fire and/or serious injury. Save all warnings and instructions for future reference.

## 2. Layout (see Fig. 1)

1. Saw table
2. Blade guard
3. Eccentric lever for the blade guard
4. Blade
5. Splitter
6. Table insert
7. Parallel stop
8. Hand wheel
9. Locking lever for blade angle
10. On/Off switch
11. Overload switch
12. Cross stop
13. Locking bolt for the parallel stop
14. Guide rail for parallel stop
15. Clamping lever for the guide rail
16. Rotary knob for the cutting width
17. Foldable stop rail
18. Push stick
19. Ring wrench
20. Combination wrench
21. Slot in the saw table

### Items supplied

- Open the packaging and take out the equipment with care.
- Remove the packaging material and any packaging and/or transportation braces (if available).
- Check to see if all items are supplied.
- Inspect the equipment and accessories for transport damage.
- If possible, please keep the packaging until the end of the guarantee period.

### Danger!

The equipment and packaging material are not toys. Do not let children play with plastic bags, foils or small parts. There is a danger of swallowing or suffocating!

## 3. Proper use

The bench-type circular saw is designed for the slitting and cross-cutting (only with the cross stop) of all types of timber commensurate with the machine's size. The equipment is not to be used for cutting any type of round wood.

The equipment is to be used only for its prescribed purpose. Any other use is deemed to be a case of misuse. The user / operator and not the manufacturer will be liable for any damage or injuries of any kind caused as a result of this.

The equipment is to be operated only with suitable saw blades (saw blades made of HM or CV). It is prohibited to use any type of HSS saw blade and cutting-off wheel.

To use the equipment properly you must also observe the safety information, the assembly instructions and the operating instructions to be found in this manual.

All persons who use and service the equipment have to be acquainted with these operating instructions and must be informed about the equipment's potential hazards. It is also imperative to observe the accident prevention regulations in force in your area. The same applies for the general rules of health and safety at work. The manufacturer will not be liable for any changes made to the equipment nor for any damage resulting from such changes. Even when the equipment is used as prescribed it is still impossible to eliminate certain residual risk factors.

The following hazards may arise in connection with the machine's construction and design:

- Contact with the saw blade in the uncovered saw zone.
- Reaching into the running saw blade (cut injuries).
- Kick-back of workpieces and parts of workpieces.
- Saw blade fracturing.
- Catastrophing of faulty carbide tips from the saw blade.
- Damage to hearing if essential ear-muffs are not used.
- Harmful emissions of wood dust when used in closed rooms.

#### 4. Technical data

SKU:	30961
Power :	1800W
Voltage:	240V/50Hz
Blade Spec :	Ø 254 x Ø 30mm x 48T
No Load Speed:	4200rpm
Cutting Capacity:	80 mm @ 90° 58 mm @ 45°
Tilting saw blade:	0° - 45°
Protection class:	II/III

Operating mode S6 25%: Continuous operation with idling (cycle time 10 minutes). To ensure that the motor does not become excessively hot, it may only be operated for 25% of the cycle at the specified rating and must then be allowed to idle for 75% of the cycle.

#### Danger!

#### Noise

The noise emission values were measured in accordance with EN 62841.

#### Operation

$L_{pA}$ sound pressure level	..... 98 dB (A)
$K_{pA}$ uncertainty	..... 3 dB (A)
$L_{WA}$ sound power level	..... 107 dB (A)
$K_{WA}$ uncertainty	..... 3 dB (A)

#### Wear ear-muffs.

The impact of noise can cause damage to hearing.

The stated noise emission values were measured in accordance with a set of standardized criteria and can be used to compare one power tool with another.

The stated noise emission values can also be used to make an initial assessment of exposure.

#### Warning:

The noise emission levels may vary from the level specified during actual use, depending on the way in which the power tool is used, especially the type of workpiece it is used for.

Keep the noise emissions and vibrations to a minimum.

- Only use appliances which are in perfect working order.
- Service and clean the appliance regularly.
- Adapt your working style to suit the appliance.
- Do not overload the appliance.
- Have the appliance serviced whenever necessary.
- Switch the appliance off when it is not in use.

#### Limit the operating time!

All stages of the operating cycle must be considered (for example, times in which the electric tools are switched off and times in which the tool is switched on but operates without load).

#### Caution!

#### Residual risks

Even if you use this electric power tool in accordance with instructions, certain residual risks cannot be ruled out. The following hazards may arise in connection with the equipment's construction and layout:

1. Lung damage if no suitable protective dust mask is used.
2. Damage to hearing if no suitable ear protection is used.

#### 5. Before starting the equipment

Before you connect the equipment to the mains supply make sure that the data on the rating plate are identical to the mains data.

#### Warning!

Always pull the power plug before making adjustments to the equipment.

- Unpack the bench-type circular saw and check it for damage which may have occurred in transit.
- The machine has to be set up where it can stand firmly, e.g. on a work bench, or it must be bolted to a strong base.
- All covers and safety devices have to be properly fitted before the machine is switched on. It must be possible for the saw blade to run freely.

- When working with wood that has been processed before, watch out for foreign bodies such as nails or screws etc.
- Before you actuate the On/Off switch, make sure that the saw blade is correctly fitted and that the machine's moving parts run smoothly.

## 6. Assembly

**Danger!** Pull out the power plug before carrying out any maintenance, resetting or assembly work on the bench-type circular saw.

### 6.1 Setting up the bench-type circular saw

- **Danger!** Make allowance for the weight of the machine and arrange for another person to help you if necessary!
- The bench-type circular saw must be stood on a level surface.
- To ensure that the saw stands securely we recommend that you fasten the bench-type circular saw on a firm substructure by the holes in the machine frame. Suitable fastening materials (screws, etc.)
- Fit the rotary knob on the shaft. Secure the rotary knob with the recessed head screw.
- Fit the extractor adapter on the extractor socket at the back of the machine.

### 6.2 Transport setting

The bench-type circular saw is set at the factory for transport. For compact transport and for optimum storage, always fasten all the loose parts in the holders provided.

- Wind the power cable onto the cable holder.
- Position the cross stop and the two wrenches on the left side of the machine.
- Fasten the push stick on the parallel stop.
- Secure the parallel stop to the guide rail.

When you want to transport or store the machine it is also advisable to set it as compactly as possible and create a level surface with the saw table. To prevent parts projecting beyond the saw table you must do the following:

- Remove the blade guard, hang it on the holder at the back of the machine and fasten it in position.
- Lower the splitter into the transport setting.

- Use the hand wheel to lower the blade so that the blade and the splitter are below the table surface.
- Use the clamping lever to slacken the guide rail. Use the rotary knob to move the guide rail to the right until it is accessible from underneath.
- With the parallel stop facing downwards, move it to the guide rail and fasten the stop at the guide screws on the outer right-hand side.
- Move the guide rail to the far left and fasten it with the clamping lever.
- To convert the saw from transport position to working position, proceed in reverse order.

### 6.3 Fitting/changing the table insert (Fig. A1-A3)

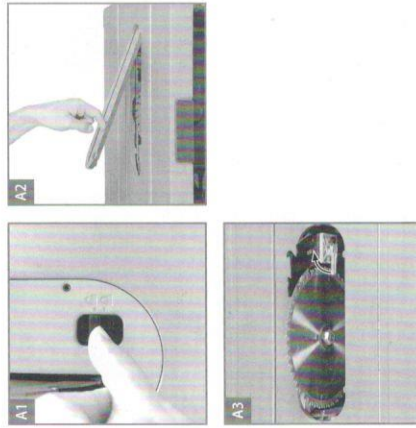

- To prevent a higher risk of injury, the table insert must be replaced whenever it becomes worn or damaged.
- Take off the saw blade guard.
- Push the switch to the position of the unlock sign in order to re-lease the table insert.
- Take out the worn table insert.
- To fit the replacement table insert, proceed in reverse order.
- **Warning!** When the workpiece is moved in feeding direction, it must not be blocked by the table insert!
- The height of the table insert relative to the saw table is set at the factory. Check the setting on a regular basis with the help of an object with a straight edge (e.g. a ruler, an angle gauge, etc.).

- Warning! The support surface of the table insert must not project at the front side!
- Warning! The support surface of the table insert must not lie below the saw table at the rear side!

#### 6.4 Moving the splitter into working position (Fig. B1-B6)

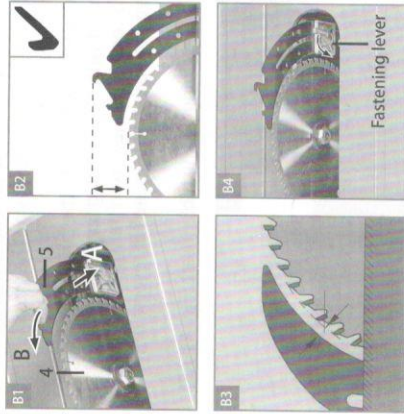

Warning! In the as-delivered state the splitter is in transport position. For operation always fasten the splitter in top position (working position) as described below.

- Using the hand wheel, set the blade to maximum cutting depth, move it to 0° position and lock it in place.
- Remove the blade guard and the table insert.
- Turn the fastening lever upwards in order to slacken the splitter.
- Press the splitter sideways in order to release the locked transport position. (see Fig. B1, arrow A)
- When the splitter is pressed sideways, guide the splitter upwards into working position. (see Fig. B1, arrow B)
- Danger! The splitter must latch in the top position! Once the splitter has latched in the top position, the fastening plate will press the splitter inwards again.
- Before you clamp the splitter, make sure that the gap between the blade and the splitter equals 3 to 8 mm. (see Fig. B3)
- Fasten the splitter using the fastening lever.
- Warning! The splitter must be fastened securely.

#### 6.5 Checking the splitter position and making necessary adjustments (Fig. C1-C2)

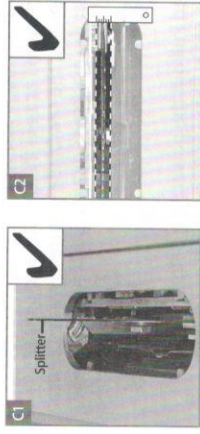

The position of the splitter relative to the blade is set at the factory. To ensure safe operation at all times, check the setting before beginning to work.

The splitter must be positioned centrally on an imaginary extended plane behind the blade so that it is impossible for the cut material to become jammed.

#### 6.6 Fitting/changing the blade guard (Fig. D1-D4)

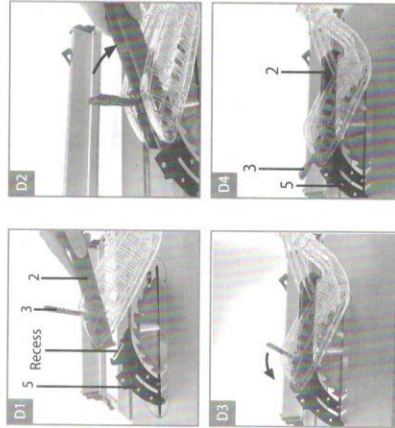

- Danger! Before operation, always fasten the blade guard (2) to the splitter (5).
- Make sure that the eccentric lever (3) is open, i.e. is pointed in the direction of the front edge of the blade guard (2).
- Guide the blade guard (2) centrally onto the splitter (5) and first hang the rear pin in the recess on the splitter.
- Then tilt the blade guard (2) downwards until the front pin is also resting in the recess on the splitter.
- Tension the blade guard (2) by pressing the eccentric lever (3) to the rear, i.e. towards the rear side of the machine.

- Warning! The saw blade guard (2) must always descend onto the workpiece automatically under its own weight.
- After mounting the saw blade guard (2), check that it works correctly by raising it and letting it go.

#### 6.7 Fitting/changing the blade (Fig. E1-E2)

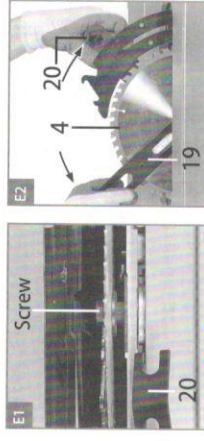

- Before changing the saw blade: Pull out the power plug!
- Wear work gloves to prevent injury when changing the blade!
- Remove the saw blade guard and the table insert.
- Release the fastening lever (Fig. A3) in order to provide access to the work area.
- Undo the screw with one wrench (19) on the screw itself and a second wrench (20) on the motor shaft to apply counter-pressure.
- Caution! Turn the screw in the direction of rotation of the blade.
- Remove the outer flange and the old blade (4) from the inner flange.
- Clean the blade flange thoroughly before fitting the new blade.
- Fit and fasten the new blade (4) in reverse order.

- Warning! Note the running direction. The cutting angle of the teeth must point in running direction, i.e. forwards (see the arrow on the blade guard).
- Secure the fastening lever again, then mount and adjust the splitter, the table insert and the blade guard (Fig. B1-B4).
- Check that all safety devices are in good working order before you begin working with the saw again.
- Warning! Every time you change the blade, check that the blade guard (2) opens and closes again in accordance with requirements. Also check that the blade (4) spins freely in the saw blade guard (2).

- Warning! Every time that you change the blade, check to see that it spins freely in the table insert (6) in both perpendicular and 45° angle settings.
- Warning! A worn or damaged table insert (6) must be replaced immediately (Fig. A1-A2).
- Warning! The work to change and align the blade (4) must be carried out correctly.

#### 6.8 Connection for dust extraction

A connection option for dust extraction is provided at the extractor adapter on the housing. For example, you can connect a wet & dry vac (not included with this product) to the extractor adapter.

#### 6.9 Fitting/removing the parallel stop (Fig. F1-F4)

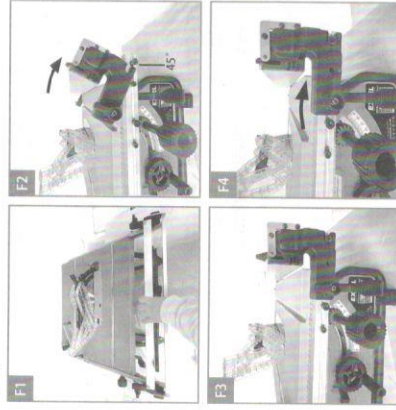

- Open the two locking bolts on the front and back sides of the parallel stop by turning the locking bolts by 90° upwards.
- To fit the parallel stop, move the position of the guide screws outwards as far as possible so that you can mount the parallel stop alongside the saw table.
- Clean any chips, dust or other dirt off the support surfaces on the parallel stop and off the guide rail.
- With the parallel stop tilted by approx. 45°, guide it by the recess onto the guide screws

- Tilt the parallel stop downwards. Make sure that the parallel stop and the retaining screw engage with each other. The mount of the parallel stop should rest over the entire width firmly on the guide rail and is not allowed to wobble.
- Secure the parallel stop by closing the two locking bolts.
- To remove the parallel stop again, proceed in reverse order.

## 7. Operation

### 7.1 On/Off switch

- To turn the saw on, press the green button "I". Wait for the blade to reach its maximum speed of rotation before commencing with the cut.
- The red button "0" is covered by the switch cover. To switch off the saw, press the switch cover.

The motor of this equipment is protected against overload by an overload switch. If the rated current is exceeded, the overload switch will shut down the equipment.

- Let the equipment cool down for several minutes.
- Press the overload switch.
- Press the green button "I" to switch on the equipment.

### 7.2 Cutting depth

Turn the hand wheel to set the blade to the required cutting depth.

**Warning!** To reduce the risk of coming into contact with the blade, always adjust the cutting depth of the blade to the thickness of the workpiece.

**Rule of thumb:** The blade should be moved in and out only as far as necessary for the tips of the blade teeth to project visibly beyond the workpiece.

Turn counter-clockwise:  
Smaller cutting depth

Turn clockwise:  
Larger cutting depth

### 7.3 Parallel stop

The parallel stop must be used when making longitudinal cuts in wooden workpieces. When you mount or adjust the parallel stop, make sure that it is aligned parallel to the blade.

#### 7.3.1 Selecting the parallel stop position

You can fasten the parallel stop in 3 different positions according to your requirements and purposes. How to fit the parallel stop on the guide rail is described.

- For smaller cutting widths you must fasten the parallel stop at the guide screws on the inner right-hand side.
- To be able to use the maximum possible cutting width, you must fasten the parallel stop at the guide screws on the outer right-hand side. **Important!** In this position you can machine only workpieces with a width of 11 cm and more.
- The parallel stop can also be fitted on the left-hand side of the blade. **Important!** In this case the cutting width cannot be read off the scale but must be set using a suitable measuring tool (e.g. a folding rule).

#### 7.3.2 Setting the foldable stop rail

The foldable stop rail performs two different functions according to the application. It can serve either to reduce the stop height of the parallel stop for narrow workpieces or to provide a supporting surface for large cutting widths.

Stop height

- **Warning!** The stop height must always be set such that the workpiece can be guided as well as possible past the blade.
- The parallel stop supplied with the product must be used together with the downward folded stop rail when you perform longitudinal cuts on narrow wooden workpieces.
- To make longitudinal cuts in wider wooden workpieces of max. 33 cm you can use the parallel stop also with the upward folded stop rail.



#### Supporting surface

- **Warning!** For cutting widths bigger than 33 cm you must fold the stop rail fully downwards so that the supporting surface of the foldable stop rail has the same height as the surface of the saw table.
- Especially with big cutting widths make sure that the workpiece lies safely on the saw table and on the foldable stop rail and that it cannot become jammed.

#### 7.3.3 Cutting width

- Fit the parallel stop on the guide rail as described.
- When the parallel stop is fitted at the guide screws on the inner right-hand side, read the set cutting width on the main scale.
- **Important!** When you fold the stop rail over the saw table for narrow cutting widths, this will reduce the actual cutting width by 5 cm compared to the cutting width reading.
- When the parallel stop is fitted at the guide screws on the outer right-hand side, read the set cutting width on the width extension scale.
- Pull the clamping lever up in order to slacken the guide rail.
- The cutting width is infinitely adjustable by turning the rotary knob.
- Use the rotary knob to move the guide rail until the pointer points to the desired dimension setting on the scale.
- Lock the set cutting width by pressing the clamping lever down.
- **Important!** If the set cutting width deviates from the actual cutting width, you can readjust the pointer. The pointer is screwed via slots to the guide rail.

#### 7.3.4 Readjusting the clamping force

**Danger!** Always ensure that the parallel stop is fastened securely on the guide rail and that the guide rail cannot slip.

- The clamping force of the clamping lever can be readjusted if necessary.
- To do so, slacken the nut and screw the threaded sleeve out or in as far as required to reach the desired clamping force.
- Finally, fasten the threaded sleeve again with the nut.

#### 7.4 Setting the blade angle (Fig. G1-G2)

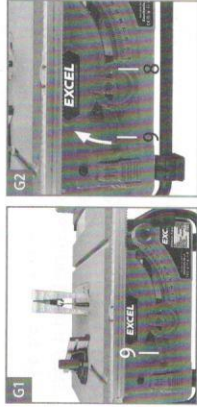

- Slacken the locking lever (9) by swinging it down.
- Adjust the blade angle by pushing the hand wheel (8) until the pointer is aligned with the desired dimension setting on the angle scale.
- Secure the angle by tightening the locking lever (9).
- **Important!** If the value deviates from the angle scale, you can readjust the pointer. The pointer is screwed in place via a slot on the machine.

#### Readjusting the end stop for the blade angle (Fig. H1-H2)

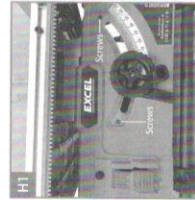

If required, the end stop for the blade angle setting can be readjusted at 0° and at 45°.

- To do so, slacken the adjustment screw for 0° or the adjustment screw for 45°.
- Use a suitable measuring tool (e.g. a 90° angle or an angle gauge) to set the angle to 90° or 45°.

- Lock the blade angle with the locking lever (9).
- Turn the eccentric plate for 0° or for 45° on the inside of the machine until it rests against the inner blade bracket.
- Secure the setting by tightening the adjustment screw.

Readjusting the clamping force of the locking lever (Fig. I1-I2)



- Remove the hand wheel (8). To do so, undo the socket head screw and pull the hand wheel (8) outwards and off.
- Undo the socket head screw and pull the locking lever (9) off the hexagon screw.
- Mount the locking lever (9) on the hexagon screw one latching position further on.
- Secure the locking lever (9) with the socket head screw.
- Mount the hand wheel (8) again and secure it with the socket head screw.

## 8. Operation

### Warning!

- After every new adjustment we recommend you to make a trial cut in order to check the new settings.
- After switching on the saw, wait for the blade to reach its maximum speed of rotation before commencing with the cut.
- Take extra care when starting the cut!
- Never use the equipment without the suction function.
- Regularly check and clean the suction channels.

### 8.1 Making longitudinal cuts

Longitudinal cutting (also known as slitting) is when you use the saw to cut along the grain of the wood. Press one edge of the workpiece against the parallel stop while the flat side lies on the saw table. The guard hood must always be lowered over the workpiece.

When you make a longitudinal cut, never adopt a working position that is in line with the cutting direction.

- Set the parallel stop in accordance with the workpiece height and the desired width.
- Switch on the saw.
- Place your hands (with fingers closed) flat on the workpiece and push the workpiece along the parallel stop and into the blade.
- Guide at the side with your left or right hand (depending on the position of the parallel stop) only as far as the front edge of the guard hood.
- Always push the workpiece through to the end of the splitter.
- The offcut piece remains on the saw table until the blade is back in its position of rest.
- Secure long workpieces against falling off at the end of the cut (e.g. with a roller stand etc.).

#### 8.1.1 Cutting narrow workpieces (Fig. J)



Be sure to use a push stick when making longitudinal cuts in workpieces smaller than 150 mm in width. A push block is supplied with the saw! Replace a worn or damaged push stick immediately. Keep the push stick always ready to hand in the holder provided.

#### 8.1.2 Cutting extremely narrow workpieces (Fig. K)



- Be sure to use a push block when making longitudinal cuts in very narrow workpieces with a width of 50 mm and less.
- The low guide face of the parallel stop is best used in this case.
- There is no push block supplied with the saw! (Available from your specialist dealer). Replace the push block without delay when it becomes worn.

**8.2 Making angular cuts with a tilted blade**  
Bevel cuts must always be used using the parallel stop.

If you tilt the saw blade to the left when making angular cuts, position the parallel stop on the right-hand side of the saw blade. Guide the workpiece between the saw blade and the parallel stop.

- Set the blade to the desired angle.
- Set the parallel stop in accordance with the workpiece width and height
- Carry out the cut in accordance with the workpiece width.

## 9. Transport

Only ever transport the machine by lifting it by the saw table. Never use the safety devices such as the saw blade guard and stop rails for handling or transporting purposes.

## 10. Replacing the power cable

**Danger!**

If the power cable for this equipment is damaged, it must be replaced by the manufacturer or its after-sales service or similarly trained personnel to avoid danger.

## 11. Cleaning, maintenance and ordering of spare parts

**Danger!**

Always pull out the mains power plug before starting any cleaning work.

### 11.1 Cleaning

- Keep all safety devices, air vents and the motor housing free of dirt and dust as far as possible. Wipe the equipment with a clean cloth or blow it with compressed air at low pressure.
- We recommend that you clean the device immediately each time you have finished using it.

- Clean the equipment regularly with a moist cloth and some soft soap. Do not use cleaning agents or solvents; these could attack the plastic parts of the equipment. Ensure that no water can seep into the device. The ingress of water into an electric tool increases the risk of an electric shock.
- Check the suction channels regularly. To clean the suction channels and remove any blockages from them, undo the recessed head screw (64) and remove the cover.  
**Caution!** The blade is freely accessible; wear protective gloves.

### 11.2 Carbon brushes

In case of excessive sparking, have the carbon brushes checked only by a qualified electrician. **Danger!** The carbon brushes should not be replaced by anyone but a qualified electrician.

### 11.3 Maintenance

There are no parts inside the equipment which require additional maintenance.

## 12. Disposal and recycling

The equipment is supplied in packaging to prevent it from being damaged in transit. The raw materials in this packaging can be reused or recycled. The equipment and its accessories are made of various types of material, such as metal and plastic. Never place defective equipment in your household refuse. The equipment should be taken to a suitable collection center for proper disposal. If you do not know the whereabouts of such a collection point, you should ask in your local council offices.

## 13. Storage

Store the equipment and accessories in a dark and dry place at above freezing temperature. The ideal storage temperature is between 5 and 30°C. Store the electric tool in its original packaging.