

EXCEL

Brushless Compact Impact Driver 18V

30367



INSTRUCTION MANUAL

DESCRIPTION OF THE SYMBOLS



Read instructions carefully before any use



Complies with relevant European regulations



The crossed-out wheeled bin symbol indicates that the item should be disposed of separately from household waste. The item should be handed in for recycling in accordance with local environmental regulations for waste disposal.

By separating a marked item from household waste, you will help reduce the volume of waste sent to incinerators or land-fill and minimize any potential negative impact on human health and the environment.

On battery



Do not expose the battery to water



Do not expose the battery to fire or incinerate

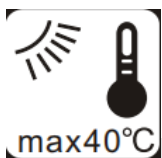

Do not expose the battery to high temperatures (above 40°C)

On charger



Class II machine – Double insulation – You don't need any earthed plug.



Use this device indoors only.

GENERAL POWER TOOL SAFETY WARNINGS



WARNING Read all safety warnings, instruction, illustrations and specifications provided with this power tool. Failure to follow all instructions listed below may result in electric shock, fire and/or serious injury.

SAVE ALL WARNINGS AND INSTRUCTIONS FOR FUTURE REFERENCE.

The term "power tool" in the warnings refers to your mains-operated (corded) power tool or battery-operated (cordless) power tool.

1) Work area safety

- a) **Keep work area clean and well lit.** Cluttered or dark areas invite accidents.
- b) **Do not operate power tools in explosive atmospheres, such as in the presence of flammable liquids, gases or dust.** Power tools create sparks which may ignite the dust or fumes.
- c) **Keep children and bystanders away while operating a power tool.** Distractions can cause you to lose control.

2) Electrical safety

- a) **Power tool plugs must match the outlet. Never modify the plug in any way. Do not use any adapter plugs with earthed (grounded) power tools.** Unmodified plugs and matching outlets will reduce risk of electric shock.
- b) **Avoid body contact with earthed or grounded surfaces such as pipes, radiators, ranges and refrigerators.** There is an increased risk of electric shock if your body is earthed or grounded.
- c) **Do not expose power tools to rain or wet conditions.** Water entering a power tool will increase the risk of electric shock.
- d) **Do not abuse the cord. Never use the cord for carrying, pulling or unplugging the power tool. Keep cord away from heat, oil, sharp edges or moving parts.** Damaged or entangled cords increase the risk of electric shock.
- e) **When operating a power tool outdoors, use an extension cord suitable for outdoor use.** Use of a cord suitable for outdoor use reduces the risk of electric shock.
- f) **If operating a power tool in a damp location is unavoidable, use a residual current device (RCD) protected supply.** Use of an RCD reduces the risk of electric shock.

3) Personal safety

- a) **Stay alert, watch what you are doing and use common sense when operating a power tool. Do not use a power tool while you are tired or under the influence of drugs, alcohol or medication.** A moment of inattention while operating power tools may result in serious personal injury.
- b) **Use personal protective equipment. Always wear eye protection.** Protective equipment such as dust mask, non-skid safety shoes, hard hat or hearing protection used for appropriate conditions will reduce personal injuries.
- c) **Prevent unintentional starting. Ensure the switch is in the off-position before connecting to power source and/or battery pack, picking up or carrying the tool.** Carrying power tools with your finger on the switch or energising power tools that have the switch on invites accidents.
- d) **Remove any adjusting key or wrench before turning the power tool on.** A wrench or a key left attached to a rotating part of the power tool may result in personal injury.

Original Instructions

- e) **Do not overreach. Keep proper footing and balance at all times.** This enables better control of the power tool in unexpected situations.
 - f) **Dress properly. Do not wear loose clothing or jewellery. Keep your hair and clothing away from moving parts.** Loose clothes, jewellery or long hair can be caught in moving parts.
 - g) **If devices are provided for the connection of dust extraction and collection facilities, ensure these are connected and properly used.** Use of dust collection can reduce dust-related hazards.
 - h) **Do not let familiarity gained from frequent use of tools allow you to become complacent and ignore tool safety principles.** A careless action can cause severe injury within a fraction of a second.
- 4) Power tool use and care**
- a) **Do not force the power tool. Use the correct power tool for your application.** The correct power tool will do the job better and safer at the rate for which it was designed.
 - b) **Do not use the power tool if the switch does not turn it on and off.** Any power tool that cannot be controlled with the switch is dangerous and must be repaired.
 - c) **Disconnect the plug from the power source and/or remove the battery pack, if detachable, from the power tool before making any adjustments, changing accessories, or storing power tools.** Such preventive safety measures reduce the risk of starting the power tool accidentally.
 - d) **Store idle power tools out of the reach of children and do not allow persons unfamiliar with the power tool or these instructions to operate the power tool.** Power tools are dangerous in the hands of untrained users.
 - e) **Maintain power tools and accessories. Check for misalignment or binding of moving parts, breakage of parts and any other condition that may affect the power tool's operation. If damaged, have the power tool repaired before use.** Many accidents are caused by poorly maintained power tools.
 - f) **Keep cutting tools sharp and clean.** Properly maintained cutting tools with sharp cutting edges are less likely to bind and are easier to control.
 - g) **Use the power tool, accessories and tool bits etc. in accordance with these instructions, taking into account the working conditions and the work to be performed.** Use of the power tool for operations different from those intended could result in a hazardous situation.
 - h) **Keep handles and grasping surfaces dry, clean and free from oil and grease.** Slippery handles and grasping surfaces do not allow for safe handling and control of the tool in unexpected situations.
- 5) Battery tool use and care**
- a) **Recharge only with the charger specified by the manufacturer.** A charger that is suitable for one type of battery pack may create a risk of fire when used with another battery pack.
 - b) **Use power tools only with specifically designated battery packs.** Use of any other battery packs may create a risk of injury and fire.
 - c) **When battery pack is not in use, keep it away from other metal objects like paper clips, coins, keys, nails, screws, or other small metal objects, that can make a connection from one terminal to another.** Shorting the battery terminals together may cause burns or a fire.
 - d) **Under abusive conditions, liquid may be ejected from the battery; avoid contact. If**

contact accidentally occurs, flush with water. If liquid contacts eyes, additionally seek medical help. Liquid ejected from the battery may cause irritation or burns.

- e) **Do not use a battery pack or tool that is damaged or modified.** Damaged or modified batteries may exhibit unpredictable behaviour resulting in fire, explosion or risk of injury.
- f) **Do not expose a battery pack or tool to fire or excessive temperature.** Exposure to fire or temperature above 130 °C may cause explosion.
- g) **Follow all charging instructions and do not charge the battery pack or tool outside the temperature range specified in the instructions.** Charging improperly or at temperatures outside the specified range may damage the battery and increase the risk of fire.

6) Service

- a) **Have your power tool serviced by a qualified repair person using only identical replacement parts.** This will ensure that the safety of the power tool is maintained.
- b) **Never service damaged battery packs.** Service of battery packs should only be performed by the manufacturer or authorized service providers.

SPECIAL SAFETY INSTRUCTIONS

1. **Use auxiliary handle(s), if supplied with the tool.** *Loss of control can cause personal injury.*
 2. **Hold power tool by insulated gripping surfaces, when performing an operation where the cutting accessory may contact hidden wiring.** *Cutting accessory contacting a "live" wire may make exposed metal parts of the power tool "live" and could give the operator an electric shock.*
 3. **Hold power tool by insulated gripping surfaces, when performing an operation where the fastener may contact hidden wiring.** *Fasteners contacting a "live" wire may make exposed metal parts of the power tool "live" and could give the operator an electric shock.*
 4. If possible, always use clamps or a vice to hold your work.
 5. Always switch off before you put the tool down.
 6. Ensure that the lighting is adequate.
 7. Do not put pressure on the tool, such that it slows the motor down. Allow the bit to screw without pressure. You will get better results and you will be taking better care of your tool.
 8. Keep the area free of tripping hazards.
 9. Only use accessory bits in good condition.
 10. Before starting, check that there is sufficient clearance for the bit under the work-piece.
 11. Do not touch the bit after operation. It will be very hot.
 12. Keep your hands away from under the work-piece.
 13. Never use your hands to remove dust, chips or waste close by the bit.
 14. Rags, cloths, cord, string and the like should never be left around the work area.
 15. Support the work properly.
 16. If you are interrupted when operating the tool, complete the process and switch off before looking up.
 17. Periodically check that all nuts, bolts and other fixings are properly tightened.
 18. When using the tool, use safety equipment including safety glasses or shield, hearing protection, and protective clothing including safety gloves. Wear a dust mask if the operation creates dust.
- 19. WARNING**
Some dust created by power sanding, sawing, grinding, drilling, and other construction activities contains chemicals known to cause cancer, birth defects or other reproductive harm.

Original Instructions

Some examples of these chemicals are:

- lead from lead-based paints,
- crystalline silica from bricks and cement and other masonry products, and
- arsenic and chromium from chemically-treated lumber.

Your risk from these exposures varies, depending on how often you do this type of work. To reduce your exposure to these chemicals: work in a well ventilated area, and work with approved safety equipment, such as those dust masks that are specially designed to filter out microscopic particles.

20. Even when the tool is used as prescribed it is not possible to eliminate all residual risk factors. The following hazards may arise in connection with the tool's construction and design:
- ✓ Damage to the lungs if an effective dust mask is not worn.
 - ✓ Damage to hearing if effective hearing protection is not worn.

EXTRA SAFETY REGULATIONS CONCERNING BATTERY

To ensure the longest battery life and best battery performance, always charge the battery when the temperature is between 18-24°C. Do not charge the battery pack when the temperature is below 0°C, or above 40°C. This is important. Failure to observe this safety rule could cause serious damage to the battery pack.

Do not incinerate the battery pack even if it is seriously damaged or can no longer hold a charge. The battery pack can explode in a fire.

A small leakage of liquid from the battery pack may occur under extreme usage or temperature. This does not necessarily indicate a failure of the battery pack. However, if the outer seal is broken and this leakage comes into contact with your skin:

- ✓ Wash the affected area quickly with soap and water.
- ✓ Flush your eyes with clean water for a minimum of 10 minutes and seek immediate medical attention.

Never attempt to open the battery pack for any reason. If the plastic housing of the battery pack breaks open or cracks, immediately discontinue its use and do not recharge it.

Do not store or carry a spare battery pack in a pocket or toolbox or any other place where it may come into contact with metal objects. The battery pack may be short circuited causing damage to the battery pack, burns or a fire. If storing or disposing the battery pack, cover the terminals with a heavy insulation tape to ensure short circuit cannot occur. Batteries, when stored for a long period of time, will discharge.

Do not store or use the tool and battery pack in locations where the temperature may reach or exceed 40°C such as alongside sheds or metal structures in the summer.

Allow the battery pack to cool down after charging. Do not place it in a hot environment such as a metal shed or open trailer left in the sun.

Only charge the battery with the charger supplied.

Do not put the battery pack near fire or high temperature position.

Do not splash or immerse in water or other liquids. This may cause premature cell failure.

When transporting individual batteries, make sure that the battery terminals are protected and well insulated from materials that could contact them and cause a short circuit.

The best storage place is one that is cool and dry away from direct sunlight and excess heat or cold.

If the battery pack has been stored for a long time, you should activate the battery pack first before using it.

The battery is to be disposed of safely.

EXTRA SAFETY REGULATIONS CONCERNING BATTERY CHARGER

This appliance can be used by children aged from 8 years and above and persons with reduced physical, sensory or mental capabilities or lack of experience and knowledge if they have been given supervision or instruction concerning use of the appliance in a safe way and understand the hazards involved.

Children shall not play with the appliance.

Cleaning and user maintenance shall not be made by children without supervision.

For indoor use only

Warning do not recharge non-rechargeable batteries

If the supply cord is damaged, it must be replaced by the manufacturer, its service agent or similarly qualified persons in order to avoid a hazard.

Before using the charger, read all the instructions and cautionary markings on the charger and battery pack as well as the instructions on the battery pack.

Only charge your battery pack indoors as the charger is designed for indoor use only.

DANGER: If the battery pack is cracked or damaged in any other way, do not insert it in the charging base. There is a danger of electric shock or electrocution.



WARNING: Do not allow any liquid to come into contact with the charger. There is a danger of electric shock.

The charger is not intended for any use other than charging the exact type of rechargeable battery pack as supplied with the charger. Any other use may result in the risk of fire, electric shock or electrocution.

The charger and battery pack supplied with it are specifically designed to work together. Do not attempt to charge the battery pack with any other charger than the one supplied.

Do not place any object on top of the charger as it could cause overheating. Do not place the charger near any heat source.

Pull on the charger to disconnect it from the power source. Do not pull on the lead.

Make sure that the charger lead is positioned where it will not be stepped on, tripped over or otherwise subjected to damage or stress.

Do not use an extension cord unless it is absolutely necessary. The use of an improper extension cord could cause the risk of fire, electric shock or electrocution.

Do not use the charger if it has been subjected to a heavy knock, dropped or otherwise damaged in any way. Take the charger to an authorized service centre for a check or repair.

Do not disassemble the charger. Take it to an authorized service centre when service or repair is required. Incorrect re-assembly may result in the risk of fire, electric shock or electrocution.

To reduce the risk of an electric shock, unplug the charger from the power supply before attempting to clean it. Removing the battery pack alone does not reduce the risk.

The charger is designed for use from a standard household electrical supply. Do not attempt to connect the charger to a supply with a different voltage.

The charger is not intended for use by persons (including children) with reduced physical, sensory or mental capabilities, or lack of experience and knowledge, unless they have been given supervision or instruction concerning use of the charger by a person responsible for their safety.

Children should be supervised to ensure that they do not play with the charger.

Do not expose charger to rain or snow.

Do not mount charger on wall or permanently affix charger to any surface. The charger is intended to use on a flat, stable surface (i.e. table top, bench top)

Never attempt to connect two chargers together.

Original Instructions

Never insert any objects into the charger's air vents. Electric shock or damage to the battery charger may result.

Disconnect the charger from the outlet before attempting any cleaning. This will reduce the risk of electric shock. Removing the battery pack will not reduce this risk.

Never recharge a fully charged battery cartridge.

Do not charge non-rechargeable batteries.

INTENDED USE

This machine is designed for drilling pilot holes for larger screws or when driving screws into harder woods.

LIST OF MAIN PARTS



1	Chuck
2	ON/OFF switch
3	Speed control button
4	LED working light
5	Forward / Reverse switch
6	Battery pack(excluded)

TECHNICAL SPECIFICATIONS

Product description	18V Li-ion brushless compact impact driver
Rated voltage of battery	18V 
Rated Speed	0-1100/0-2150/0-3000 min-1
Impact Frequency	0-1500/0-3000/0-3800 bpm
Chuck	1/4"
Max torque	220 N.m
Sound pressure level L_{pA} ($K_{pA} = 3dB(A)$)	76.30dB(A)
Sound power level L_{WA} ($K_{WA} = 3dB(A)$)	87.30dB(A)
Level of vibration a_h ($K = 1.5m/s^2$)	0.5923m/s ²
Battery and Charger	
Recommended battery	a)BA-1820B,Li-ion 18V d.c. 2.0Ah
	b)BA-1850B,Li-ion 18V d.c. 5.0Ah
Recommended charger	1. Model : CH-1802A Input : 100-240V~ 50Hz 60W Output : 20V DC 2.3A Charging time : a)60MIN b)140MIN
	2. Model :CH-1802B Input : 100-240V~ 50Hz 125W Output : 20VDC, 5A Charging time : a)30MIN b)70MIN
	3. Model :CH-1802D Input : 100-240V~ 50Hz 130W Output : 20VDC, 2.3AX2, USB × 2, 5VDC MAX 2A Charging time : a)60MIN b)140MIN

NOISE/VIBRATION INFORMATION

Measured sound values determined according to EN 62841.

Wear hearing protection!

Vibration total values (triax vector sum) determined according to EN 62841: The vibration emission level given in this information sheet has been measured in accordance with a standardized test given in EN 62841 and may be used to compare one tool with another. It may be used for a preliminary assessment of exposure. The declared vibration emission level represents the main applications of the tool. However if the tool is used for different applications, with different accessories or poorly maintained, the vibration emission may differ. This may significantly increase the exposure level over the total working period. An estimation of the level of exposure to vibration should also take into account the times when the tool is switched off or when it is running but not actually doing the job. This may significantly reduce the exposure level over the total working period. Identify additional safety measures to protect the operator from the effects of vibration such as: maintain the tool and the accessories, keep the hands warm, organization of work patterns avoid vibration risk.

Vibration risk limitation suggestions:

- 1) wear glove during operation
- 2) limit operating time and shorten trigger time.

Before using the equipment

Battery charger (Fig.1)

The lithium-ion battery can be charged at any time and will not develop a “memory” when charged after only a partial discharge. It is not necessary to run down the battery pack charge before recharging. Remove the battery pack from the tool when convenient for you and your job. You can “top-off” your battery pack’s charge before starting a big job or long period of use.

Due to lithium-ion’s fade-free properties, the only time it is necessary to charge the lithium-ion battery pack is when the pack has reached the end of its charge. To signal the end of charge, power to the tool will drop quickly. Charge the battery pack as needed.

Fig.1



a. Charging the battery

This lithium-ion battery pack is shipped partially charged. Before using it the first time, fully charge the battery pack. A fully discharged battery pack with a temperature between 5°C and 35°C will charge in about 30-140MIN(See section”Specifications”).

CH-1802A:

- Plug the charger adapter into power source. The green light on the charger stand will illuminate, indicating the charger is powered.
- Slide the battery all the way into the charger stand until it locks in place with a click. The red light on the charger stand will illuminate, indicating that the battery is charging.
- The red light will go off after charging is complete and a green light will appear.

CH-1802B/CH-1802D:

See the manual of CH-1802B/CH-1802D

NOTE: Batteries may become warm while charging. This is normal. If the battery is hot after continuous use in the tool, allow it to cool down to room temperature before charging. This will extend the life of your batteries.

WARNING: Always disconnect the battery pack from the tool before any assembly, adjustments or changing accessories.

b. Insertion and removal of rechargeable battery (Fig.2)

Depress the battery-release button located on the front of the battery pack to release battery pack.

Pull the battery pack out and remove it from the tool.



Fig. 2

OPERATION

Install the bits

Due to the impact mechanism you should use only bits, which are designed for operation with impact screwdrivers of greater or equal torque than the torque of the product.

Installation must be carried out when the battery is removed from the product to prevent injury. The product cannot be used with standard drill bits.

The bits are not supplied with the product. Use bits with the chuck size of 6.3 mm (1/4 in).

- Pull the locking sleeve of the tool holder (**Fig. 3**).
- Insert the bit into the opening of the tool holder. Release the locking sleeve (**Fig. 4**).

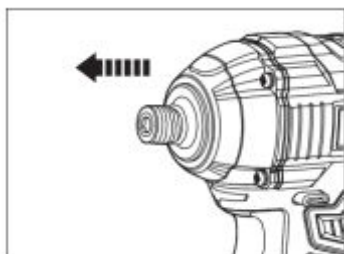

Fig.3

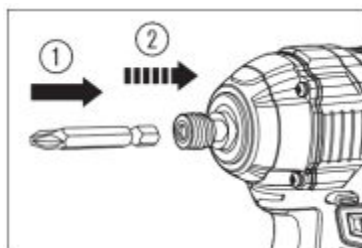

Fig.4

Setting the rotation direction

1. To set the tighten rotation direction, press the forward / reverse rotation control switch through to the left stop (**Fig. 5**).
2. To set the loosen rotation direction, press the forward / reverse rotation control switch through to the right stop (**Fig. 6**).

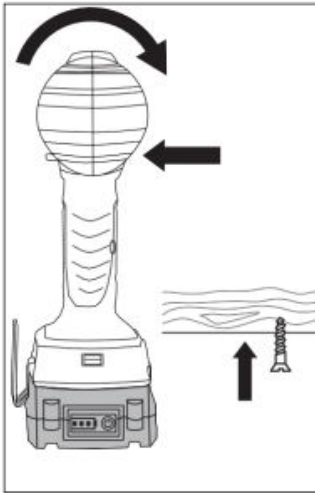

Fig.5

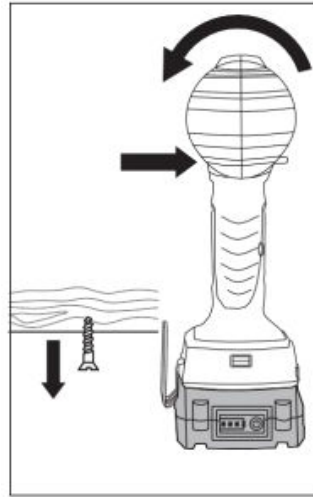
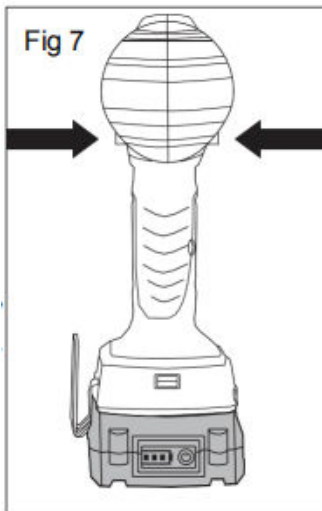

Fig.6

3. To lock the on/off switch (1), press the forward / reverse rotation control switch through to the centre position (**Fig 7**).



Operation tips

The working procedure is divided into two steps: Screwing in and tightening (impact mechanism in action). The impact mechanism is activated as soon as the screwed connection is tight and therefore load is put on the motor (the power of the motor to transfer to steady rotary impacts).

- Only apply the power tool to the screw/bolt or nut when the tool is switched off. Rotating bits can slip off and damage the thread.
- During operation you should begin with a slow rotation speed and increase it in the course of work if needed. The rotation speed can be controlled by pressing the on/off switch to varying extents.
- It is recommended to perform the first few turns manually by hand, key or a screwdriver to ensure the correct screwing in of a component.
- In case of working with threaded components, do not exert too much pressure on the product. This can lead to the damage of the thread.
- Before screwing larger/longer screws it is advisable to predrill a pilot hole (using a different drill) with the core diameter of the thread to approx. 2/3 of a given screw length.
- Always hold the product perpendicularly to the point to be screwed. Holding it at an angle may cause slipping or jamming of the screw/bolt.

Original Instructions

Switching the product on/off

After tightening the screw/nut, the product's impact mechanism starts to "bump". The maximum impact duration should not exceed 1-2 seconds.

The product is equipped with a work light to illuminate the work area. The work light turns on when the product is in operation, and turns off automatically when the product is off.

1. To switch on the product, press the on/off switch.
2. To switch off the product, release the on/off switch.

The speed of the product can be adjusted by pressing the on/off switch to varying extents. A light pressure on the on/off switch results in a low rotational speed. Increased pressure on the switch causes an increase in speed.

Speed controller

You can select the speed by enter the speed controller.



Using belt clip

The belt clip can be used to hook the product on a work belt for temporary storage while working. Before storing, set the on/off switch lock to the centre position to prevent the product from accidentally starting.

SERVICE & MAINTENANCE

Always remove the battery from the tool before performing any adjustment or maintenance operation.

Take care not to expose this tool to the rain.

Keep the ventilation openings clear and clean the product regularly.

Repair of the tool must only be carried out by a qualified repair technician.

Repair or maintenance by unqualified personnel can lead to a risk of injury.

Use only identical spare parts for repairing a tool

Cleaning

Avoid using solvents when cleaning plastic parts. Most plastic parts are susceptible to damage from various types of commercial solvents and may be damaged by their use. Use clean clothes to remove dirt, carbon dust, etc.

Storing

Store the machine, operating instructions and where necessary the accessories in the original packaging. In this way you will always have all the information and parts ready to hand.

Pack the device well or use the original packaging in order to avoid transit damage.

Always keep the machine in dry place.

Disposal



Electronic devices are recyclable waste and must not be disposed of in the household waste. At the end of its service life, dispose of the product according to the relevant statutory regulations.



Remove any rechargeable battery, if necessary, and dispose of it separately from the product.

You thus fulfil your statutory obligations and contribute to environmental protection.

Exceltools.co.uk
Sales@exceltools.co.uk