

# **EXCEL**

---

Original operating instructions

**MITRE SAW**

**Model: 5156**

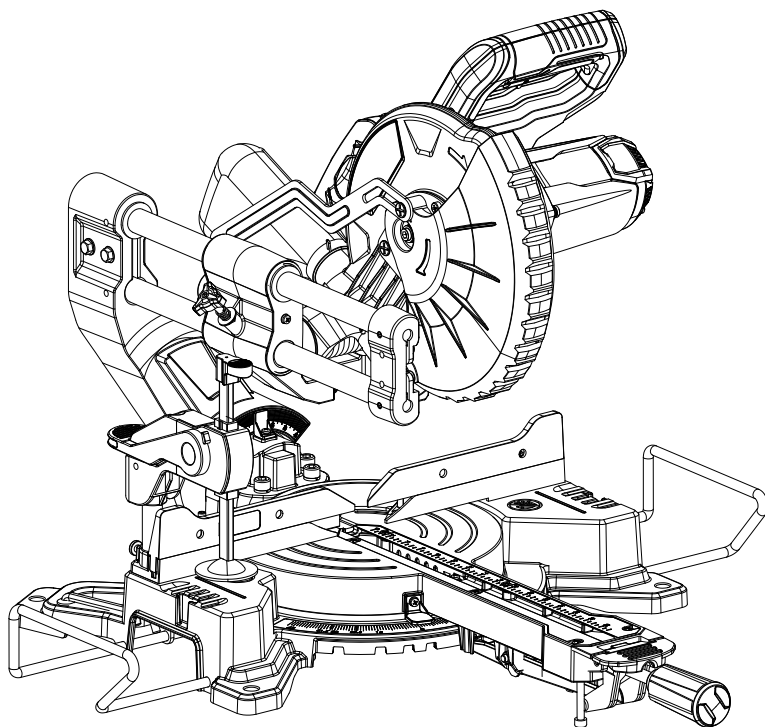

2021

**Danger! Read all safety regulations and instructions.  
Keep all safety regulations and instructions in a safe place for future use.**

# **CONTENTS**

- **SYMBOLS**
- **GENERAL SAFETY INSTRUCTIONS**
- **SAFETY REGULATIONS CONCERNING MITRE SAW**
- **SAFETY RULES FOR LASER LIGHTS**
- **RESIDUAL RISKS**
- **KNOWYOUR PRODUCT**
- **INTENDED USE**
- **NOT INTENDED USE**
- **SPECIFICATIONS**
- **ASSEMBLE & ADJUSTMENT**
- **OPERATING**
- **MAINTENANCE**
- **ENVIRONMENTAL PROTECTION**
- **SERVICE**
- **GUARANTEE**

# SYMBOLS



WARNING - To reduce the risk of injury, user must read the instruction manual



Wear gloves protection



Warning



Wear ear protection



Wear eye protection



Wear respiratory protection



Caution! Risk of injury! Do not reach into the running saw blade.



Double insulated for additional protection.



Conforms to relevant safety standards



Waste electrical products should not be disposed of with household waste. Please recycle where facilities exist. Check with your Local Authority or retailer for recycling advice.



In accordance with essential requirements for products sold in the United Kingdom.

# GENERAL SAFETY INSTRUCTIONS



**WARNING!** Read all safety warnings instructions, illustrations and specifications provided with this power tool. *Failure to follow the warnings and instructions may result in electric shock, fire and/or serious injury. The term "power tool" in the warnings refers to your mains-operated (corded) power tool or battery-operated (cordless) power tool.*

**Save all warnings and instructions for future reference.**

## 1) Work area safety

- a) **Keep work area clean and well lit.** *Cluttered and dark areas invite accidents.*
- b) **Do not operate power tools in explosive atmospheres, such as in the presence of flammable liquids, gases or dust.** *Power tools create sparks which may ignite the dust or fumes.*
- c) **Keep children and bystanders away while operating a power tool.** *Distractions can cause you to lose control.*

## 2) Electrical safety

- a) **Power tool plugs must match the outlet. Never modify the plug in any way. Do not use any adapter plugs with earthed (grounded) power tools.** *Unmodified plugs and matching outlets will reduce risk of electric shock.*
- b) **Avoid body contact with earthed or grounded surfaces such as pipes, radiators, ranges and refrigerators.** *There is an increased risk of electric shock if your body is earthed or grounded.*
- c) **Do not expose power tools to rain or wet conditions.** *Water entering a power tool will increase the risk of electric shock.*
- d) **Do not abuse the cord. Never use the cord for carrying, pulling or unplugging the power tool. Keep cord away from heat, oil, sharp edges or moving parts.** *Damaged or entangled cords increase the risk of electric shock.*
- e) **When operating a power tool outdoors, use an extension cord suitable for outdoor use.** *Use of a cord suitable for outdoor use reduces the risk of electric shock.*
- f) **If operating a power tool in a damp location is unavoidable, use a residual current device (RCD) protected supply.** *Use of an RCD reduces the risk of electric shock.*

## 3) Personal safety

- a) **Stay alert, watch what you are doing and use common sense when operating a power tool. Do not use a power tool while you are tired or under the influence of drugs, alcohol or medication.** *A moment of inattention while operating power tools may result in serious personal injury.*
- b) **Use safety equipment. Always wear eye protection.** *Safety equipment such as dust mask, non-skid safety shoes, hard hat, or hearing protection used for appropriate conditions will reduce personal injuries.*
- c) **Prevent unintentional starting. Ensure the switch is in the off-position before connecting to power source and/or battery pack, picking up or carrying the tool. Carrying power tools with your finger on the switch or energizing power tools that have the switch on invites accidents.**

- d) **Remove any adjusting key or wrench before turning the power tool on.** *A wrench or a key left attached to a rotating part of the power tool may result in personal injury.*
- e) **Do not overreach. Keep proper footing and balance at all times.** *This enables better control of the power tool in unexpected situations.*
- f) **Dress properly. Do not wear loose clothing or jewellery. Keep your hair, clothing and gloves away from moving parts.** *Loose clothes, jewellery or long hair can be caught in moving parts.*
- g) **If devices are provided for the connection of dust extraction and collection facilities, ensure these are connected and properly used.** *Use of these devices can reduce dust related hazards .*
- h) **Do not let familiarity gained from frequent use of tools allow you to become complacent and ignore tool safety principles.** *A careless action can cause severe injury within a fraction of a second.*

#### 4) Power tool use and care

- a) **Do not force the power tool. Use the correct power tool for your application.** *The correct power tool will do the job better and safer at the rate for which it was designed.*
- b) **Do not use the power tool if the switch does not turn it on and off.** *Any power tool that cannot be controlled with the switch is dangerous and must be repaired.*
- c) **Disconnect the plug from the power source before making any adjustments, changing accessories, or storing power tools.** *Such preventive safety measures reduce the risk of starting the power tool accidentally.*
- d) **Store idle power tools out of the reach of children and do not allow persons unfamiliar with the power tool or these instructions to operate the power tool.** *Power tools are dangerous in the hands of untrained users.*
- e) **Maintain power tools. Check for misalignment or binding of moving parts, breakage of parts and any other condition that may affect the power tools operation. If damaged, have the power tool repaired before use.** *Many accidents are caused by poorly maintained power tools.*
- f) **Keep cutting tools sharp and clean.** *Properly maintained cutting tools with sharp cutting edges are less likely to bind and are easier to control.*
- g) **Use the power tool, accessories and tool bits etc., in accordance with these instructions and in the manner intended for the particular type of power tool, taking into account the working conditions and the work to be performed.** *Use of the power tool for operations different from intended could result in a hazardous situation.*
- h) **Keep handles and grasping surfaces dry, clean and free from oil and grease.** *Slippery handles and grasping surfaces do not allow for safe handling and control of the tool in unexpected situations.*

#### 5) Service

- a) **Have your power tool serviced by a qualified repair person using only identical replacement parts.** *This will ensure that the safety of the power tool is maintained.*

## SAFETY REGULATIONS CONCERNING MITRE SAW

- a) **Mitre saws are intended to cut wood or wood-like products, they cannot be used with abrasive cut-off wheels for cutting ferrous material such as bars, rods, studs, etc.** *Abrasive dust causes moving parts such as the lower guard to jam. Sparks from abrasive cutting will burn the lower guard, the kerf insert and other plastic parts.*
- b) **Use clamps to support the workpiece whenever possible. If supporting the workpiece by hand, you must always keep your hand at least 100 mm from either side of the saw blade. Do not use this saw to cut pieces that are too small to be securely clamped or held by hand. If your hand is placed too close to the saw blade, there is an increased risk of injury from blade contact.**
- c) **The workpiece must be stationary and clamped or held against both the fence and the table. Do not feed the workpiece into the blade or cut “freehand” in any way.** *Unrestrained or moving workpieces could be thrown at high speeds, causing injury.*
- d) **Push the saw through the workpiece. Do not pull the saw through the workpiece. To make a cut, raise the sawhead and pull it out over the workpiece without cutting, start the motor, press the saw head down and push the saw through the workpiece.** *Cutting on the pull stroke is likely to cause the saw blade to climb on top of the workpiece and violently throw the blade assembly towards the operator.*
- e) **Never cross your hand over the intended line of cutting either in front or behind the saw blade.** *Supporting the workpiece “cross handed” i.e. holding the workpiece to the right of the saw blade with your left hand or vice versa is very dangerous.*
- f) **Do not reach behind the fence with either hand closer than 100 mm from either side of the saw blade, to remove wood scraps, or for any other reason while the blade is spinning.** *The proximity of the spinning saw blade to your hand may not be obvious and you may be seriously injured. outside bowed face toward the fence. Always make certain that there is no gap between the workpiece, fence and table along the line of the cut. Bent or warped workpieces can twist or shift and may cause binding on the spinning saw blade while cutting. There should be no nails or foreign objects in the workpiece.*
- g) **Do not use the saw until the table is clear of all tools, wood scraps, etc., except for the workpiece.** *Small debris or loose pieces of wood or other objects that contact the revolving blade can be thrown with high speed.*
- i) **Cut only one workpiece at a time.** *Stacked multiple workpieces cannot be adequately clamped or braced and may bind on the blade or shift during cutting.*
- j) **Ensure the mitre saw is mounted or placed on a level, firmwork surface before use.** *A level and firmwork surface reduces the risk of the mitre saw becoming unstable.*
- k) **Plan your work. Every time you change the bevel or mitre angle setting, make sure the adjustable fence is set correctly to support the workpiece and will not interfere with the blade or the guarding system.** *Without turning the tool ON2 and with no workpiece on the table, move the saw blade through a complete*

*simulated cut to assure there will be no interference or danger of cutting the fence.*

- l) **Provide adequate support such as table extensions, saw horses, etc. for a workpiece that is wider or longer than the table top.** *Workpieces longer or wider than the mitre saw table can tip if not securely supported. If the cut-off piece or workpiece tips, it can lift the lower guard or be thrown by the spinning blade.*
- m) **Do not use another person as a substitute for a table extension or as additional support.** *Unstable support for the workpiece can cause the blade to bind or the workpiece to shift during the cutting operation pulling you and the helper into the spinning blade.*
- n) **The cut-off piece must not be jammed or pressed by any means against the spinning sawblade.** *If confined, i.e. using length stops, the cut-off piece could get wedged against the blade and thrown violently.*
- o) **Always use a clamp or a fixture designed to properly support round material such as rods or tubing.** *Rods have a tendency to roll while being cut, causing the blade to bite and pull the work with your hand into the blade.*
- p) **Let the blade reach full speed before contacting the workpiece.** *This will reduce the risk of the workpiece being thrown.*
- q) **If the workpiece or blade becomes jammed, turn the mitre saw off. Wait for all moving parts to stop and disconnect the plug from the power source and/or remove the battery pack. Then work to free the jammed material.** *Continued sawing with a jammed workpiece could cause loss of control or damage to the mitre saw.*
- r) **After finishing the cut, release the switch, hold the saw head down and wait for the blade to stop before removing the cut-off piece.** *Reaching with your hand near the coasting blade is dangerous.*
- s) **Hold the handle firmly when making an incomplete cut or when releasing the switch before the sawhead is completely in the down position.** *The braking action of the saw may cause the sawhead to be suddenly pulled downward, causing a risk of injury.*

## RESIDUAL RISKS

Even if you use this electric power tool in accordance with instructions, certain residual risks cannot be ruled out. The following hazards may arise in connection with the equipment's construction and layout:

1. Lung damage if no suitable protective dust mask is used.
2. Damage to hearing if no suitable ear protection is used.
3. Health damage caused by hand-arm vibrations if the equipment is used over a prolonged period or is not properly guided and maintained.



### WARNING!

This product produces an electromagnetic field during operation! This field may under some circumstances interfere with active or passive medical implants! To reduce the risk of serious or fatal injury, we recommend persons with medical implants to consult their doctor and the medical implant manufacturer before operating this product!

# KNOWYOUR PRODUCT

## PARTS LIST

1. Operating handle
2. On/off switch release lever
3. Upper fixed blade guard
4. Spindle locking button
5. Guard mounting plate
6. Lower retractable blade guard
7. Saw blade(In guard)
8. Right adjustable fence
9. Extendable workpiece support
10. Mounting hole
11. Base
12. Turntable locking handle
13. Mitre angle adjustment lever
14. Support bolt
15. Table insert
16. Turntable
17. Mitre scale
18. Left adjustable fence
19. Workpiece clamp
20. Multi-tool
21. Workpiece clamp locking knob
22. Bevel scale
23. Sliding locking knob
24. On/off switch
25. Dust extraction outlet
26. Dust collection bag
27. Sliding bar
28. Bevel locking handle
29. Adjustable fence locking knob
30. Extendable support locking knob
31. Workpiece clamp holder
32. Locking bolt
33. Laser On/Off switch
34. Laser module

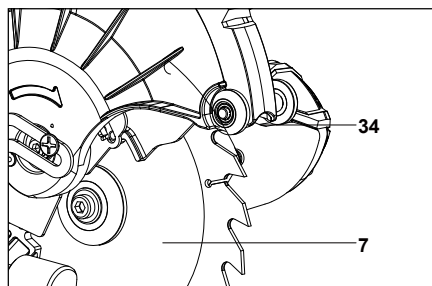
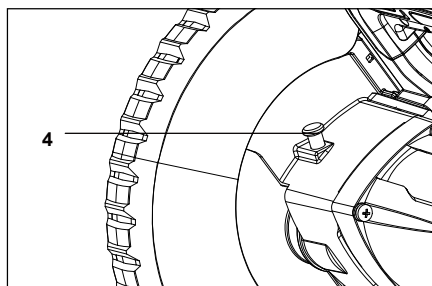
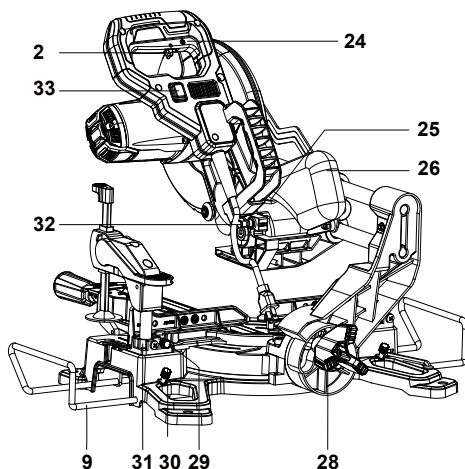
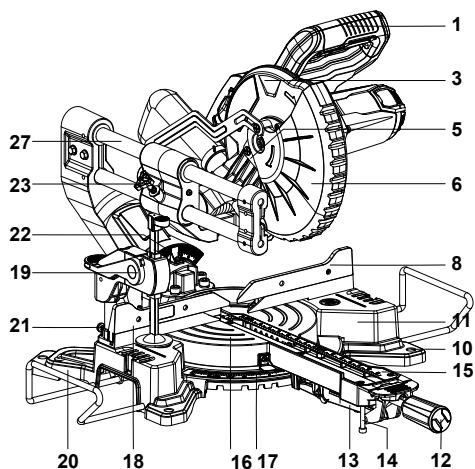



## INTENDED USE

This mitre saw is intended for cutting wood and analogue materials, it is suitable for straight and curved cuts having Mitre angles of up to 45°. The saw is not designed for cutting firewood. Do not use machines, tools and accessories for additional applications (see manufacturer's instructions) for works other than those for which they are designed for. All other applications are expressly ruled out.

## NOT INTENDED USE

If not intended use, the risk of fire, electric shock and personal injury maybe further.

- The provisions contained in this guarantee are not intended to limit, modify, take away from, disclaim or exclude any statutory guarantee set forth in any applicable provincial or federal legislation.

## SPECIFICATIONS

TECHNICAL DATA • Voltage : 220-240V ~ 50Hz

- Power rating: 1500W
- No-load speed : 4800 /min
- Blade size : Ø216mm x 48T
- LpA sound pressure level .....97 dB(A)  
KpA uncertainty .....3 dB(A)
- LWA sound power level .....108 dB(A)  
KWA uncertainty .....3 dB(A)

### Noise information

The noise emission and its uncertainty measured in accordance with EN62841-1. Wear hearing protection! The noise figures quoted are emission levels and actual use of the power tool can differ from the declared are not necessarily safe working levels.

### Vibration



#### WARNING!

– the vibration emission during actual use of the power tool can differ the total value of depending on the different ways in which the tool is used; and avoid vibration risk suggestion:

- 1) wear glove during operation
- 2) limit operating time and shorten

### Vibration and noise reduction

To reduce the impact of noise and vibration emission, limit the time of operation, use low-vibration and low-noise operating modes as well as wear personal protective equipment. Take the following points into account to minimize the vibration and noise exposure risks:

1. Only use the product as intended by its design and these instructions.
2. Ensure that the product is in good condition and well maintained.

3. Use correct application tools for the product and ensure they in good condition.
4. Keep tight grip on the handles/grip surface.
5. Maintain this product in accordance with these instructions and keep it well lubricated (where appropriate).
6. Plan your work schedule to spread any high vibration tool use across a number of days.

## CUTTING CAPACITY

- Mitre table angles : 0° to 45° to the left & right
- Bevel cuts : 0° to 45° to the left
- Straight cut at 0° x 0° : 30.5 x 7 cm
- Mitre cut at 0° x 45° : 21.5 x 7 cm
- Bevel cut at 45° x 0° : 30.5 x 3.5 cm
- Compound mitre cut at 45° x 45° : 21.5 x 3.5 cm
- Net weight : 15kg

## ACCESSORIES

The Compound Mitre Saw is supplied with the following accessories as standard:

- Saw blade (fitted)
- Multi-tool (6 mm hex key/ cross screwdriver)
- Workpiece Clamp
- Dust bag
- Side support bars x2
- Instruction manual

## ASSEMBLE & ADJUSTMENT

**Important:** Be sure the supply is the same as the voltage given on the rating plate. Remove the mains plug before carrying out any adjustment or servicing.



**Warning!** To prevent the accidental starting that could cause possible serious personal injury, ALWAYS assemble all parts to you saw BEFORE connecting it to the power supply. The saw should NEVER be connected to a power supply when you are assembling parts, making adjustments, installing or removing blades, or when not in use.

### 1. DUST EXTRACTION PORT

- To reduce build up of saw dust and maintain top efficiency of cutting, the saw dust collection can be achieved by clipping a dust bag on the dust extraction port.
- A dust bag (26) is provided for use on you mitre saw. To install it, simply fit the dust bag over the extraction port (25) on the upper blade guard.
- To empty the dust bag, remove it from the dust exhaust port, open the dust by unzipping the slide fastener.
- **Note:** to ensure optimal dust collecting, empty the dust bag when it becomes filled to approximately 2/3 of its capacity.

## 2.MOUNTING HOLES

- Before use, the saw can be fixed to a firm, level surface with the 4 mounting bolts (10) (Not supplied).
- Four holes are provided in the base of the saw to enable it to be fixed to a bench, or other supporting surface.
- To mount the saw, process as follows:
  - 1) Locate and mark where the saw is to be mounted.
  - 2) Drill 4 holes through the surface.
  - 3) Place the mitre saw on the surface aligning holes in base when holes drilled in the surface. Install holes, washers and nuts.



**CAUTION!** Make sure that the mounting surface is not warped as an uneven surface can cause binding and inaccurate sawing.

## 3.WORKPIECE CLAMP

- When cutting workpiece, the boards should always be clamped with the Workpiece Clamp (19) (provided).
- The workpiece clamp is preassembled. Insert the height adjustment pillar into the workpiece clamp holder (31) on either side of the base if necessary.

## 4. EXTENDABLEWORKPIECE SUPPORT

For supporting long workpiece, fix the Extendable workpiece support (9) and adjust the length to suit the long work pieces. Then tighten the locking knob (30) of base.

## 5. RELEASE BOLT

When boxed or during storage, transportation, the saw head is locked in the down position. To release the head ready for operation. Apply downward pressure on the saw arm and pull out the release bolt (32), rotate the knob to unlock the saw head. The head will be raised gently to upper position. The saw must never be used with the release bolt locking the head down.

## 6. MITRE TABLE LOCKS

- The turntable locking handle (12) are used to lock the table at the desired mitre angle.
- The mitre sawcuts from  $0^{\circ}$  to  $45^{\circ}$  both left and right. To adjust the mitre angle loosen the turntable locking handle (12) anticlockwise and uplift adjustment lever (13) then rotate the mitre table to the desired position.
- The mitre table features positive click stops at  $0^{\circ}$  ,  $15^{\circ}$  ,  $22.5^{\circ}$  ,  $30^{\circ}$  and  $45^{\circ}$  for quick setting of common mitre angles.

## 7. BEVEL LOCK

The bevel locking handle (28) is used to set the blade at the desired bevel angle. The mitre saw bevel cuts from  $0^{\circ}$  to  $45^{\circ}$  to the left. To adjust the bevel angle loosen the bevel lock anticlockwise and adjust the saw arm to the desired bevel angle.

## **8. SPINDLE LOCK BUTTON**

The spindle lock button (4) prevents the blade in the saw from rotating. Depress and hold the spindle lock button while installing, changing, or removing the blade.

## **9. ROTATING LOWER BLADE GUARD**

The rotating lower blade guard (6) provides protection from both sides of the blade. It retracts over the upper blade guard (3) as the saw is lowered into the workpiece.

## **10. FENCE ADJUSTMENT**

- Turn the fence locking knob (29) anticlockwise to loosen it.
- Slide the adjustable fence (8, 18) to 3-8mm
- Tighten the fence locking knob (29) afterward.

## **11. CHANGING A BLADE**

- Make sure that the electrical plug is removed from the power point.
- Press the blade guard release lever (2) and then rotate the lower retractable blade guard (6) upwards to expose the screw.
- Loosen the screw on the guard mounting plate (5) with the provided multi tool.
- Slide the guard mounting plate (5) upwards to expose the saw blade (7). The lower retractable blade guard (6) will be held by the blade guard. The lower retractable blade guard (6) will be held by the blade guard.
- Press the spindle lock button (4) fully and hold it in position.
- Turn the clamping screw slightly with the provided multi tool (20) until the spindle is locked.
- Loosen the clamping screw in clockwise direction and remove it together with the outer flange and saw blade (7). Do not remove the inner flange from the spindle
- Place a new saw blade on the spindle and make sure that the bore of the saw blade properly fits the inner flange. Ensure that the rotational direction indicated on the saw blade is the same as the one shown on the upper fixed blade guard (3).
- Secure the saw blade (7) with the outer flange and clamping screw. Tighten the clamping screw in anti-clockwise direction with the provided tool.
- Turn the saw blade by hand to test if it is rotating smoothly. It should not flutter.
- Secure the guard mounting plate (5) and lower retractable blade guard (6) in reverse order as described above.
- Switch the product on and let it run idle for about one minute, to confirm that the saw blade has been installed properly. If you find any abnormal vibration or excessive noise switch the product off and refit the saw blade according to the above instructions.

# OPERATION

## TRANSPORTATION

1. When transporting the saw with fixed locations, make sure that the saw head is locked in the lower position.
2. The rotary table locking knob, the bevel lock knob and slide lock must all be securely tightened.
3. The saw is switched off and the plug is removed from the power point.
4. Only lift the saw by the operating handle (1) or outer castings. Do not lift the saw using the guards.
5. For locking the saw head in the down position, Apply downward pressure on the operating handle (1) and pull out the release bolt (32), rotate the release bolt to lock the saw head. The head will be locked in down position.

## TURNING ON AND OFF

1. To turn the saw on, push switch lock (2) and depress the on/off trigger switch (24).
2. To turn the saw off release the on/off trigger switch (24).

## Laser ON/OFF

Switch ON/OFF the Laser lights with the ON/OFF switch (33). Press laser switch at " I " place to ON, Press at " 0 " place to OFF.

## SLIDE CUTTING

- To slide cut wide boards, Unlock the slide lock knob (23) and allow the cutting head assembly to move freely.
- Pull the operating handle (1) forwards until the centre of the saw blade (7) is directly over the front edge of the workpiece.
- Hold the operating handle (1) firmly and push switch lock (2) and depress the on/off trigger switch (24). Allow the saw blade (7) to reach maximum speed.
- Slowly lower the blade to the workpiece.
- Only apply proper feeding force. Excessive feeding force will not increase but lower the performance of the product, overheat the blade tips and leads to low cutting surface/edge quality.
- Switch the product off and allow the saw blade to come to a complete stop before lifting it from the workpiece.

## MITRE CUT

- Mitre cutting is the same as cutting, except that the mitre angle is set to an angle other than  $0^\circ$ .
- Adjust the turntable (16) to the required mitre angle. Make sure the turntable locking handle (12) is locked firmly.
- Follow the same instruction of "Slide cutting".

## BEVEL CUT

- Bevel cutting is the same as cutting, except that the saw blade bevel angle is set to an angle other than  $0^\circ$ .
- Adjust the saw blade (7) to the desired bevel angle. Make sure the bevel angle

locking handle (28) is locked firmly.

- Follow the same instruction of “Slide cutting”..

## COMPOUNDBEVEL&MITRE CUT

- This sawing operation combines a mitre angle with a bevel angle.
- Adjust the turntable (16) to the required mitre angle. Make sure the turntable locking handle (12) is locked firmly.
- Adjust the saw blade (7) to the desired bevel angle. Make sure the bevel angle locking handle (28) is locked firmly.
- Follow the same instruction of “Slide cutting”.

## MAINTENANCE

 **WARNING:** Remove the plug from the socket before carrying out any adjustment, servicing or maintenance.

1. When all the adjustments, settings or maintenance have been done, make sure that all keys and wrenches have been removed and that all screws, bolts and other fittings are securely tightened.
2. Keep the tool's air vents unclogged and clean at all times. Occasionally you may see sparks through the ventilation slots. This is normal and will not damage your power tool.
3. Regularly check to see if any dust or foreign matter has entered the grills near the motor and around the trigger switch. Use a soft brush to remove any accumulated dust.
4. Wear safety glasses to protect your eyes whilst cleaning.
5. If the body of the saw needs cleaning, wipe it with a soft damp cloth. A mild detergent can be used but nothing like alcohol, petrol or other cleaning agent.
6. Never use caustic agents to clean plastic parts.

 **CAUTION!** Water must never come into contact with the saw.

7. Store the tool, instruction manual and accessories in a secure place. In this way you will always have all the information and parts on hand.

## GENERAL INSPECTION

1. Regularly check that all the fixing screws are tight. They may vibrate loose over time. Check especially the outer flange. If there is vibration, screws can loosen with time.
2. Regularly check the device's power cable and all extension cables used for damage. If the supply cord needs replacing, the task must be carried out by the manufacturer, the manufacturer's agent, or an authorized service centre in order to avoid a safety hazard. Replace damaged extension cables.
3. If the carbon brushes need to be replaced, have this done by a qualified repair person (always replace the two brushes at the same time).

## ENVIRONMENTAL PROTECTION



**CAUTION!** This product has been marked with a symbol relating to removing electric and electronic waste. This means that this product shall not be discarded with household waste but that it shall be returned to a collection system which conforms to the European WEEE Directive. Contact your local authorities or stockist for advice on recycling. It will then be recycled or dismantled in order to reduce the impact on the environment. Electric and electronic equipment can be hazardous for the environment and for human health since they contain hazardous substances.

## SERVICE

- Tool service must be performed only by qualified repair personnel. Service or maintenance performed by unqualified personnel could result in a risk of injury.
- When servicing a tool, use only identical replacement parts. Follow instructions in the Maintenance section of this manual. Use of unauthorized parts or failure to follow Maintenance Instructions may create a risk of electric shock or injury.