

# ***EXCEL***

## ***16" Electric Chain Saw***



**MODEL:11790**

# **INSTRUCTION MANUAL**

**Exceltools.co.uk**

## 1. Introduction

### Dear Customer,

We hope your new tool brings you much enjoyment and success.

### Note:

According to the applicable product liability laws, the manufacturer of the device does not assume liability for damages to the product or damages caused by the product that occurs due to:

- Improper handling,
- Non-compliance of the operating instructions,
- Repairs by third parties, not by authorized service technicians,
- Installation and replacement of non-original spare parts,
- Application other than specified,

A breakdown of the electrical system that occurs due to the non-compliance of the electric regulations and regulations.

### We recommend:

Read through the complete text in the operating instructions before installing and commissioning the device. The operating instructions are intended to help the user to become familiar with the machine and take advantage of its application possibilities in accordance with the recommendations. The operating instructions contain important information on how to operate the machine safely, professionally and economically, how to avoid danger, costly repairs, reduce downtimes and how to increase reliability and service life of the machine.

In addition to the safety regulations in the operating instructions, you have to meet the applicable regulations that apply for the operation of the machine in your country. Keep the operating instructions package with the machine at all times and store it in a plastic cover to protect it from dirt and moisture. Read the instruction manual each time before operating the machine and

carefully follow its information. The machine can only be operated by persons who were instructed concerning

the operation of the machine and who are informed about the associated dangers. The minimum age requirement must be complied with.

## 2. Scope Of Delivery

- Open the packaging and remove the device carefully.
- Remove the packaging material as well as the packaging and transport bracing (if available).
- Check that the delivery is complete.
- Check the device and accessory parts for transport damage.
- If possible, store the packaging until the warranty period has expired.

### Attention

The device and packaging materials are not toys!

Children must not be

allowed to play with plastic bags, film and small parts!

There is a risk of swallowing and suffocation!

## 3. Safety Instructions

**The safety instructions must be observed when using the chainsaw. For your own safety and the safety of others, please read this information carefully before using the chainsaw and keep it in a safe place for reference. Use the chainsaw only to saw wood or objects made of wood. Any other types of use are at your own risk and could be dangerous. The manufacturer cannot be held liable for damage caused by improper or incorrect usage.**

### Safety instructions and accident prevention

**To prevent the incorrect handling of the chainsaw, please read the operating instructions in their entirety before using the chainsaw for the first time. All the information on the handling of the chainsaw is relevant to your personal safety. Ask a professional to show you how to use the chainsaw!**

- Before plugging in, check the plug and cable for damage. If damage is discovered, have it repaired by a specialist immediately.
- Never use a damaged cable, connection or plug or a power cable which does not comply with the requirements. If the cable is damaged or severed, unplug immediately.

- Switch the chainsaw off before releasing the chain brake.
- To prevent injury, wear tight-fitting clothes and safety boots.
- To prevent damage to your hearing, wear earmuffs, helmets with a visor are particularly advantageous. Make sure you have a firm footing when working with the chain saw.
- Keep your place of work tidy.
- To prevent electric shock, avoid contact with earthed parts.
- Always pull the plug out of the power socket before doing any work on the chainsaw.
- Only plug in when the chainsaw is switched off,
- The chainsaw must be used only by one person at a time. All other persons must stay clear of the chainsaw's area of swing. Children and pets in particular must be kept well away at all times.
- The saw must not be touching anything when it starts up.
- Hold the chainsaw firmly in both hands when working with it.
- The chain saw must not be operated by children and young people. The only exception to this prohibition are young persons of 16 years and over who can use the chain saw under supervision as part of their training. Lend the saw only to those persons who are familiar with this type of chainsaw and know how to handle it. Always pass on the operating instructions together with the chainsaw.
- Make sure the chain saw is stored in a place inaccessible to children.
- The saw may be operated only by persons who are rested and in good health, i.e. in a good physical condition. If you start to tire, have a break in time. The chainsaw should not be used after the consumption of alcohol.
- Never expose the chainsaw to rain or bad weather. Make sure there is enough light at the place of work. Do not use power tools in the vicinity of combustible liquids or gases.

- If the chainsaw is not being used for a while, it must be set aside in such a way that no other person is endangered.
- Before making a cut, always set the claw stop before you start to saw.
- Remove the chainsaw from the wood only with the saw chain still running. Anyone who saws without a stop can be pulled forwards.
- Never use the chainsaw when standing on a ladder, in a tree or in any other instable places. Do not saw with one hand.
- The power cable must always be behind the saw operator.
- The power cable must always lead away from the rear of the chainsaw.
- Use only original accessories.
- **Chainsaws used outdoors must be connected up to an earth-leakage circuit-breaker.**
- Do not overload your power tools. They run best and safest within given range of capacity.
- Always use the correct power tool. Do not use low-powered chainsaws for heavy jobs.
- Use the cable only for its proper purpose. Never carry your electric tool by its cable. Do not use the cable to pull the plug out of the socket. Protect the cable from heat, oil and sharp edges.
- Extension cables out of doors. Use only authorized and accordingly labelled extension cables out of doors.
- Use a strong support when sawing converted timber and thin branches (saw-horse, Fig. 7b). Do not stack the timber and do not have it held by a second person or with your foot.
- Logs must be secured in position.
- On sloping ground, always work facing upwards.
- When cross-cutting always set the claw stop against the timber you want to saw (see Fig. 7b)

- Always set the claw stop before cross-cutting. Only then switch on the chainsaw and start sawing into the wood. Pull the chainsaw upwards at the rear and lead the direction with the front grip. Use the claw stop as a fulcrum. To reposition for further cutting, interrupt the sawing process and exert a slight pressure on the front grip. Pull the saw back a little, position the claw stop further down the cut and pull up the rear grip (see Fig. 7a).
- Pull the saw out of the wood only when the saw chain is running.
- If you carry out several cuts, switch off the chain saw in-between.
- Plunge cuts and horizontal cuts may only be carried out by professionals (high risk of kick-back, see Fig. 8).
- For horizontal cuts, position the smallest possible angle. This requires extreme caution, as the claw stop can not be applied in this case.
- If the chain gets stuck when sawing with the upper side it may be thrust towards the operator. For this reason you should saw wherever possible with the bottom side, as the chainsaw will then be thrust away from the body towards the wood (see Fig. 9 and 10).
- Pay extra attention when cutting splintered wood. Sawed off pieces of wood may be catapulted in any direction (risk of injury!)
- Do not use the chainsaw to remove or similar objects.
- When lopping off branches, the chain saw should be supported wherever possible against the trunk, Do not cut with the tip of the guide bar (risk of kick-back, see Fig. 8).
- Leave branch lopping work should be carried out by trained personnel! Risk of injury!
- Pay special attention to branches under tension. Do not cut through freely suspended branches from underneath.
- Never stand on the trunk when lopping off branches.

- The chainsaw should not be used for forest work, i.e. for felling and lopping off branches in the forest. Because of the cable connection the saw operator does not have the necessary mobility and his safety is not guaranteed!
- Always stand to the side of the tree being felled.
- When the tree is being felled, watch out for falling branches when stepping back.
- On slopes the saw operator should stand to the upper or left or right side the trunk or lying tree, never to the bottom side.
- Watch out for trunks rolling towards you. **Kick-back!**
- The power saw is likely to recoil if the tip of the guide bar (especially the top quarter) accidentally touches wood or any other solid objects. In this case the saw will move uncontrolled and will be hurled towards the operator at full power (**risk of injury!**).

**In order to prevent kick-back, please follow these safety instructions:**

- Never start cutting with the tip of the guide bar!
- Never cut with the tip of the guide bar! Be careful, when continuing cuts you are already working on!
- Always start cuts with the chainsaw already running!
- Make sure that the saw chain is always properly sharpened.
- Never cut through more than one branch at a time! When lopping off branches, be careful not to touch any other branches.
- When cross-cutting, pay attention to trunks standing very close to each other. If possible use a saw-horse.

#### **4. Transporting the chainsaw**

Before transporting the chainsaw, always remove the plug from the power socket and slide the chain guard over the rail and chain. If several cuts are to be performed with the chain saw, the saw must be switched off between cuts.

## 5. Intended Use

The power tool is intended for sawing wood such as wooden beams, planks, branches, tree trunks, etc., and for sawing of trees. Cuts can be sawed with or across the grain.

This power tool is not suitable for sawing mineral materials.

## 6. Before starting up

The voltage and current supply must comply with the ratings on the type plate. Before commencing work, always check that the chainsaw works properly and is safe to operate. Check also that the chain lubrication and the oil gauge are in good working order (see Fig.4). When the oil lever is approx. 5 mm from the bottom mark, you must top up with oil. When the oil level is above this mark you can work without worry. Switch on the chain saw and hold it above the ground. Be careful not allow the chainsaw to touch the ground. For safety reasons it is best to keep a clearance of at least 20 cm. If you now see growing traces of oil, the chain lubrication system is working correctly. If there are no traces of oil at all, try cleaning the oil outlet (Fig 2, C), the upper chain tensioning borehole (E) and the oil duct, or contact your Customer Service. (Be sure to read the section "Filling in chain oil and chain lubrication" on this point). Check the chain tension and retention if necessary (see the section "Tensioning the saw chain" on this point). Make sure the chain brake is working properly (see also the section "Releasing the chain brake").

## 7. Technical Data

### Specifications:

<b>Voltage -</b>	<b>230-240V / 50Hz</b>
<b>Power -</b>	<b>2400W</b>
<b>Chain Speed -</b>	<b>15m/s</b>
<b>Length of Blade -</b>	<b>16 Inch</b>
<b>Engine Oil Tank Capacity -</b>	<b>150ml</b>
<b>Cable Length -</b>	<b>6m</b>
<b>Oregon Chain and Oregon Bar</b>	
<b>With Quick Release Blade Function</b>	

## 8. Product Features

1. Rear grip
2. Front grip
3. Front finger guard / Chain break
4. Saw chain
5. SDS system
6. Guide bar cover
7. Guide bar
8. Rear finger guard
9. Power cable
10. Claw stop
11. Safety lock-off button
12. Cable hook
13. ON/OFF switch
14. Oil tank cap
15. Oil gauge
16. Chain wheel
17. Guide bolt
18. Chain tensioning bolt

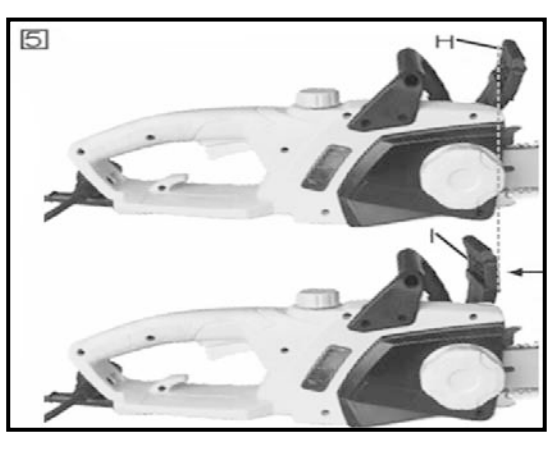
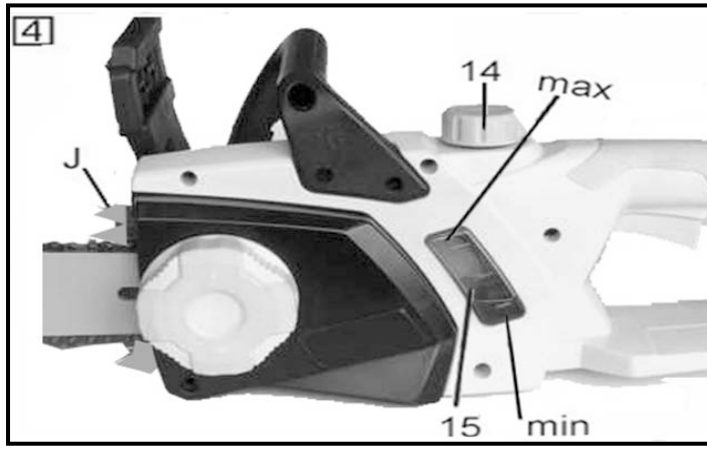
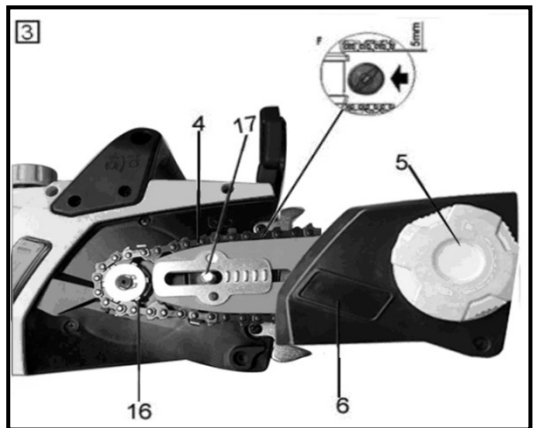
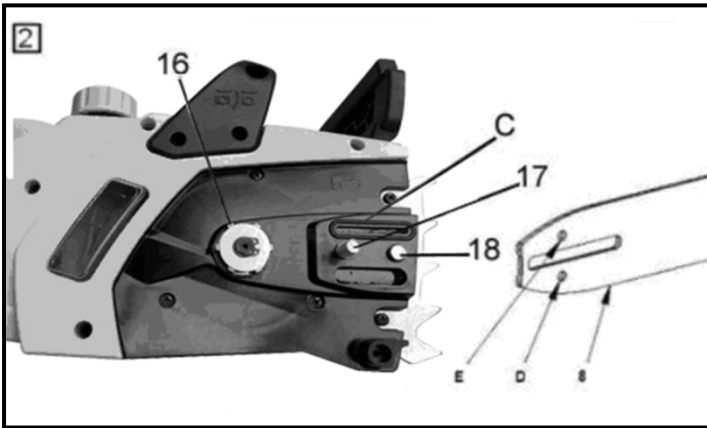
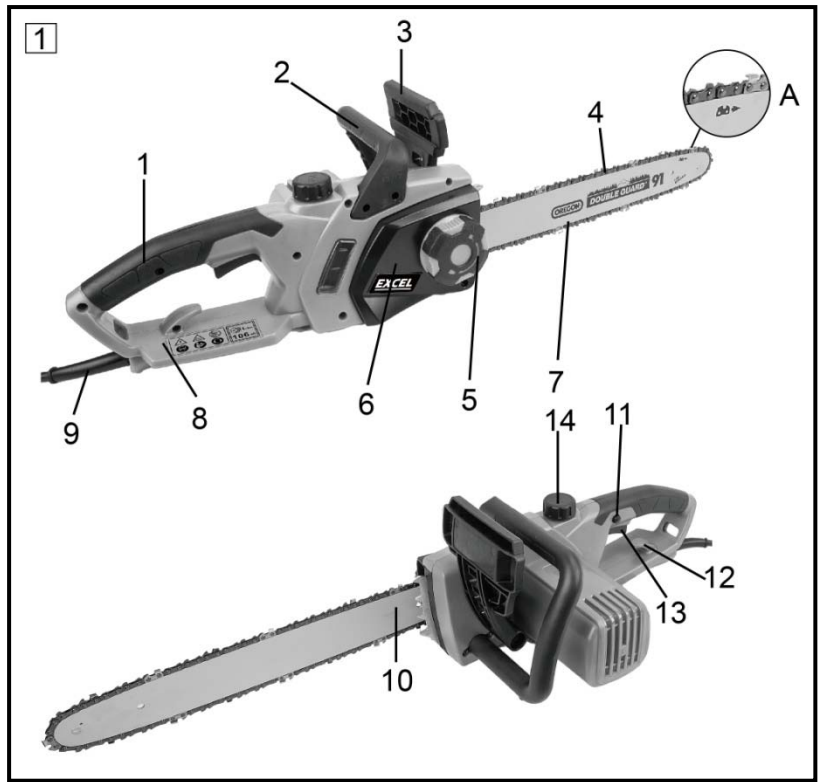

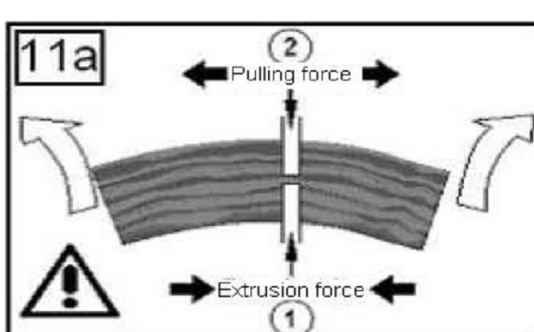
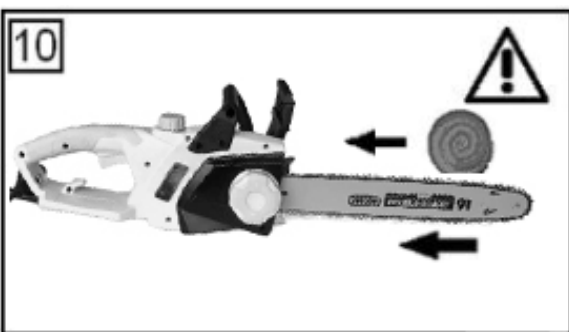
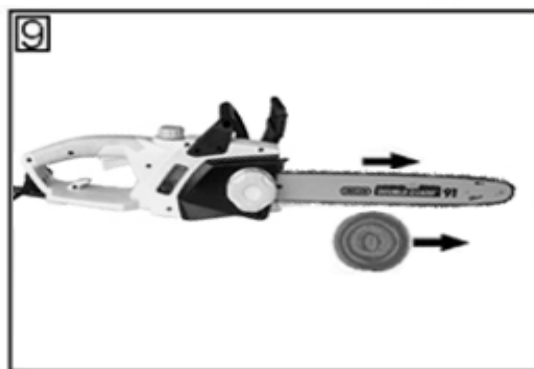
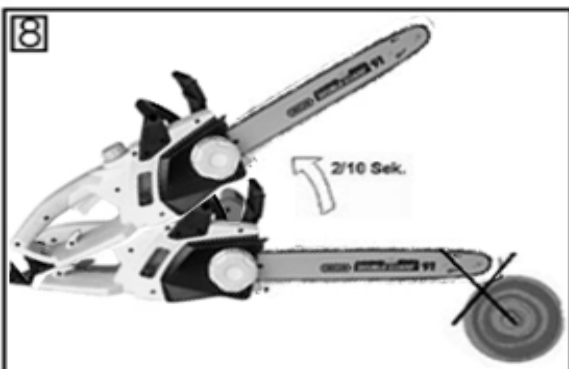
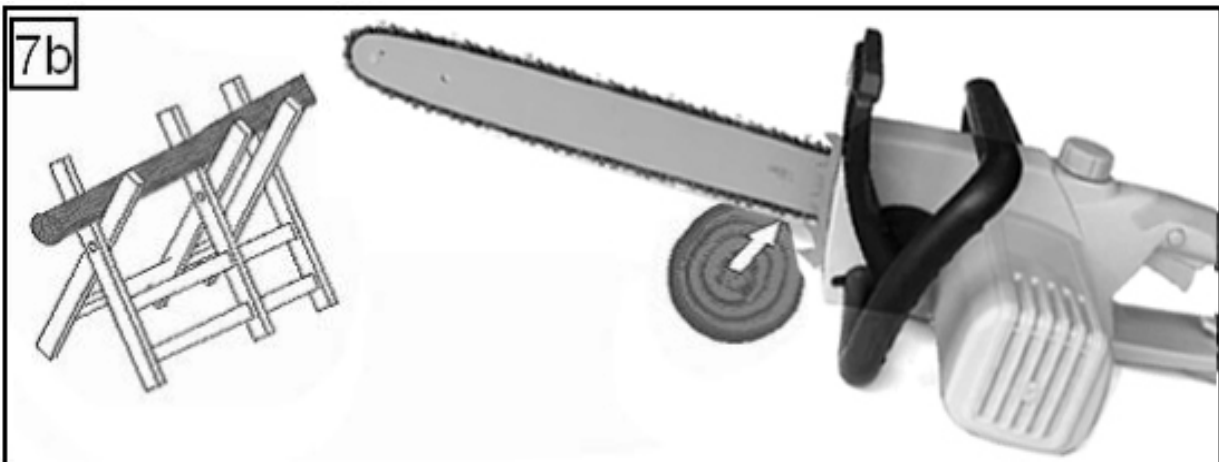
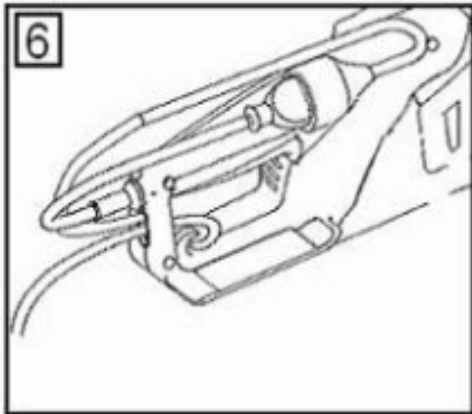

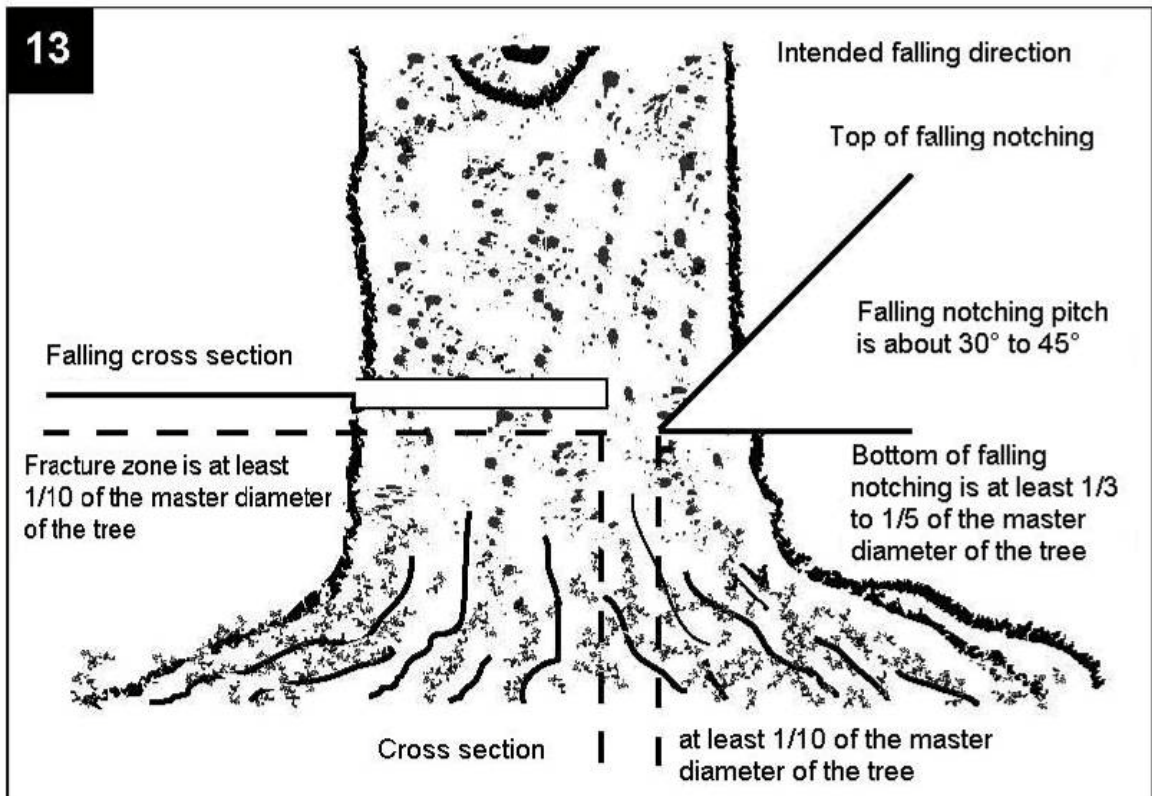
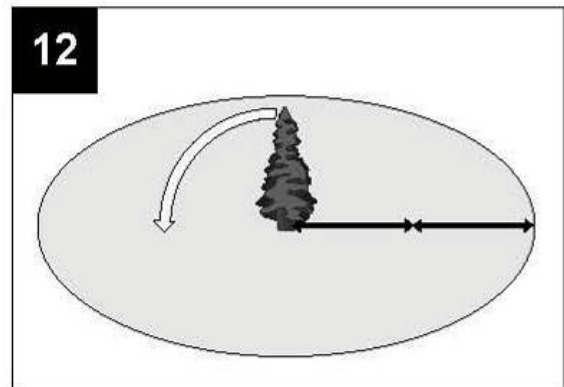
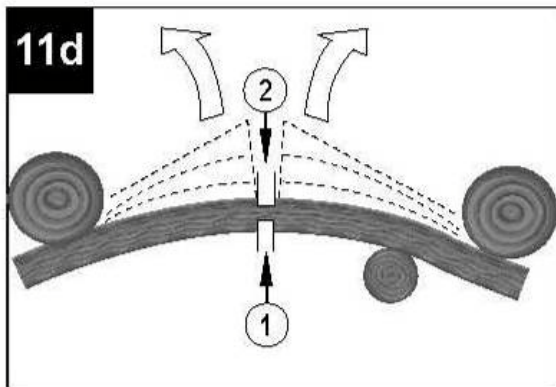
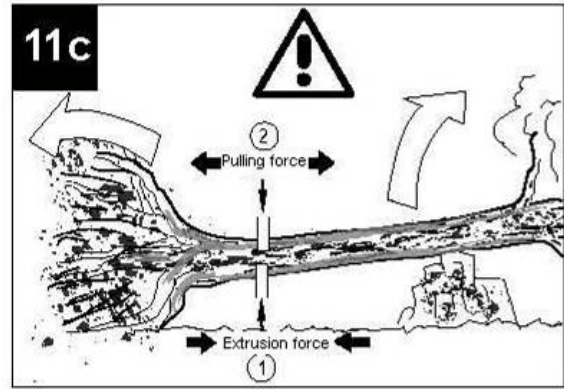
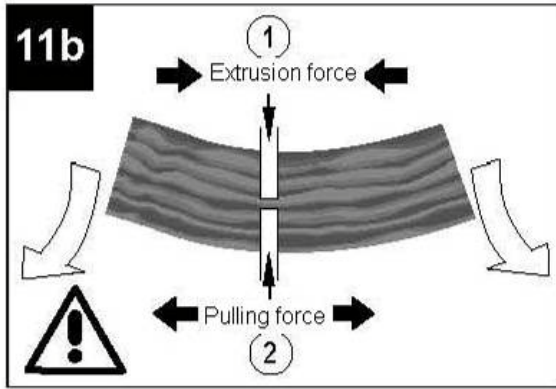



## 9. Assembly

### Assembling the guide bar and saw chain(Fig1,2,3)

**The chainsaw must be unplugged.**

**Important:The front finger guard (3) must always be in the top (vertical) position (Fig. 5).**

The guide bar and saw chain are supplied separately. To assemble, first unscrew the lock knob (5) and remove the guide bar cover (6). The chain tensioning bolt (18) must be in the center of the guide. If necessary, adjust the chain tensioning bolt with the screw (16). To prevent injury on the sharp cutting edges, always wear gloves when assembling, tensioning and checking the chain. **Before assembling the guide bar with the saw chain, check the cutting direction of the teeth!** The running direction is marked with an arrow on the Fig 1 (A). To determine the direction of cut, it may be necessary to turn over the saw chain (4). Hold the guide bar (7) vertically with the tip pointing upwards and put on the saw chain (4) beginning at the tip of the bar. Then assemble the guide bar with the saw chain as follows: Place the guide bar with the saw chain on the guide bolt (17) and chain tensioning bolt (18). Place the saw chain round the chain wheel (16) and make sure it is correctly mounted (see Fig.3). Place the guide bar cover (6) on top and tighten gently with the lock knob (5) by hand. Now the saw chain has to be correctly tensioned.

### **Tensioning the saw chain**

**Always pull the plug out of the power socket before doing any work on the chainsaw!**

**Wear safety gloves!**

Make sure the saw chain (4) is inside the guide groove of the guide bar (7) (Fig.1 A)!

Turn the lock knob (5) clockwise by hand until the saw chain is correctly tensioned. Do not tension the chain too tightly. When cold, it should be possible to lift the chain in the middle of the guide bar approx 5 mm. Tighten the guide bar cover (6) securely.

When warm, the saw chain will expand and slacken and there is a danger of it jumping off the rail altogether. Re-tension if necessary. If the saw chain is re-tensioned when hot, it must be loosened again when the sawing work has been completed. Otherwise, the contraction which takes place as the chain cools would result in excessively high tension. A new saw chain requires a running-in period of approx .5 minutes. Chain lubrication is very important at this stage. After running in, check chain tension and re-tension if necessary.

## 10.Operation instructions

### Filling in chain oil (Fig 4)

To prevent dirt getting inside the tank, clean the oil tank cap (21) before opening. Check the contents of the oil tank during sawing work by checking the oil gauge (15). Close the oil tank cap tightly and wipe away any spills.

### Securing the extension lead (Fig 6)

Only use extension leads suitable for outdoor use. The cross section of the cable (max. length of extension cord: 75m) must be at least 1,5 mm<sup>2</sup>. secure the chainsaw flex to the extension lead by inserting the extension lead into the strain relief gap of the housing. Extension leads longer than 30 m will reduce the performance of the chainsaw.

### **Chain lubrication**

To prevent excessive wear, the saw chain and guide bar must be evenly lubricated during operation.

Lubrication is automatic. Never work without chain lubrication. If the chain runs dry, the entire cutting apparatus will quickly become severely damaged. It is therefore important to check both chain lubrication and the oil gauge every use (Fig. 4).

Never use the saw when the oil level is below the "Min." mark.

●**Min.:** When only approx. 5 mm of oil is visible at the lower rim of the oil gauge (15), you must top up with oil.

●**Max.:** Top up with oil until the window is full.

### **Checking the automatic lubrication**

Before commencing work, check the automatic chain lubrication and oil gauge. Switch on the chain saw and hold it above the ground. Be careful not to allow the chain saw to touch the ground. For safety reasons it is best to keep a clearance of at least 20 cm. If you now see growing traces of oil, the chain lubrication system is working correctly. If there are no traces of oil at all, try cleaning the oil outlet (Fig 2, C), the upper chain tensioning borehole (E) and the oil duct, or contact your Customer Service.

### **Chain lubricants**

The service life of saw chains and guide bars depends to a large extent on the quality of the lubricant used. Old oil must not be used! Use only environment-friendly chain lubricant. Store chain lubricant only in containers which comply with the regulations.

### **Guide bar**

The guide bar (7) is subjected to especially severe wear and tear at the nose and the bottom. To avoid one-sided wear and tear, turn the guide bar over every time when you sharpen the chain.

### **Chain wheel**

The chain wheel (16) is subjected to especially high wear and tear. If you notice deep wear marks on the teeth, the chain wheel must be replaced. A worn chain wheel curtails the service life of the saw chain. Have the chain wheel replaced by a specialist dealer or your Customer Service.

### **Chain guard**

The chain guard must be clipped onto the chain and sword as soon as the sawing work has been completed and whenever the chainsaw has to be transported.

### **Chain brake**

In the event of kick-back, the chain brake (3) will be actuated via the front finger guard. The front finger guard is pushed forwards by the back of the hand and this causes the chain brake to stop the chain saw, or rather the motor, within 0.12 s (Fig 5, I).

### **Releasing the chain brake** (Fig 5)

To be able to use your chain saw again, you must release the saw chain again. First switch off the chainsaw. Then push the front finger guard (3) back into the vertical position until it locks in place (Fig 5, H). The chain brake is now fully functional again.

### **Sharpening the saw chain**

You can have your saw chain sharpened fast and correctly by specialist dealers, from whom you can also obtain chain sharpening equipment to enable you to sharpen the chain yourself. Please follow the corresponding operating instructions.

Take care of your tools. Keep your tools sharp and clean to enable you to work well and safely. Follow the maintenance regulations and the instructions for changing tools

### **Starting up**

#### **Always wear safety goggles, ear muffs, protective gloves and heavy-duty work clothes!**

Use the saw only with approved extension cables with the prescribed insulation and connections designed for outdoor use (approved rubber-sheathed cables) which fit the chainsaw plug. The chain saw is equipped with a two-handed safety switch. The chainsaw works only when one hand holds the front grip (2) and the other hand actuates the switch on the rear grip (1) .

If the chainsaw does not run, the chain brake must be released at the front finger guard (3). Be sure to read the sections "Chain brake" and " Releasing the chain brake " on this point.

#### **After switching on, the chainsaw will run immediately at high speed.**

**To switch off:** Release either the ON/OFF switch (13) on the rear grip or the other switch (2) on the rear grip. The release of ON/OFF switch results the stop of the chainsaw within 2sec., and heavy sparking. This is normal and safe for the proper operation of the chainsaw.

**After working with the chainsaw, you should always:** Clean the saw chain and guide bar and replace the chain guard.

#### **Chainsaw protection**

**Never use the chainsaw in the rain or in damp conditions.**

**If the extension cable is damaged, pull the plug out of the power socket immediately. Never work with a damaged cable.**

Check the chainsaw for damage. Before using your tool again, check the safety devices or any slightly damaged parts to ensure that they are in good working order. Make sure the moving parts are working correctly. All the parts must be correctly assembled and meet all the conditions required to ensure that the chainsaw works correctly. Any damaged safety devices and parts must be properly repaired or replaced immediately by a Customer Service workshop, unless there are instructions to the contrary in these operating instructions.

#### **Notes on working practice**

##### **Kick-back (Fig 8)**

**You can avoid accidents by not sawing with the tip of the guide bar as this may cause the saw to rear up suddenly.**

**Always use the complete safety equipment and clothes when working with the saw.**

Kick-back is an upward and/or backward movement of the guide bar which can occur if the saw chain at the tip of the guide bar encounters an obstruction.

Make sure your work-piece is firmly secured. Use clamps to stop the work-piece slipping. This also makes it easier to operate the chainsaw with both hands.

Kick-back causes the saw to behave uncontrollably and thus brings with a slack or blunt chain. A poorly sharpened chain increases the risk of kick-back. Never saw above shoulder height.

#### **Tips on chain saw use**

##### **Sawing up wood (Fig 7a, 7b)**

To saw up wood, please observe the safety regulations and proceed as follows: Make sure the wood to be sawed cannot slip. Clamp short pieces of wood in place before sawing. Saw only wood or wooden objects. When sawing, make sure that no stones or nails are touched as these could be thrown out and damage the saw chain. Avoid bringing the running saw into contact with wire fences or the ground. When lopping off branches, support the chainsaw as far as possible and do not saw with the tip of the guide bar. Watch out for obstacles such as tree stumps, roots, ditches and hillocks as these could cause you to fall.

##### **Remember:**

The chainsaw must be running before it comes into contact with the wood.

To switch on: Press the safety lock-off (2) and ON/OFF switch on (13). Place the lowest claw (Fig 4, J) on the wood. Raise the chain saw by the rear grip (2) and saw into the wood. Move the chain saw back a little and place the claw further down. Be careful when sawing splintered wood as pieces of wood may be ripped off.

##### **Wood under tension**

###### **Fig 11a: Top side of under tension**

**Danger: Tree will rear up!**

###### **Fig 11b: Bottom side of trunk under tension**

**Danger: Tree will move downwards!**

###### **Fig 11c: Thick trunks and high tension**

**Danger: Tree will move suddenly and with immense force!**

###### **Fig 11d: Both sides of trunk under tension**

**Danger: Tree will move sideways.**

##### **Felling trees**

To fell trees, observe all the safety regulations and proceed as follows:

The chain saw may be used to fell only trees which are smaller in diameter than the length of the motor still running. If the saw chain gets jammed, release it using a wooden wedge.

**Remember:**

**Danger zone:** Falling trees can bring down other trees with them. The danger zone is therefore twice the length of the tree being felled. (Fig, 12)

**Felling trees is dangerous and requires practice. If you are a beginner or inexperienced, do not try to teach yourself but seek professional training.**

(Fig, 13)

**Falling direction:**

- First estimate the direction of fall, taking into account the centre of gravity of the crown and the wind direction. The chain saw must be running before it comes into contact with the wood. Switch on the chain saw. Saw an undercut in the tree in the direction of fall and then make a horizontal cut (back cut) on the side opposite to the undercut.

- Make the undercut: This will give the tree a direction and guidance.

- Check the direction of fall: If you have to correct the undercut, always re-cut over the entire width.

- Call now "Timber! "

- Only now make the back cut, which must be higher than the sole of the undercut. Insert wedges in time.

- Leave the bridge in place as it will function as a hinge. If you cut through the bridge, the tree will fall randomly.

- **Fell the tree by driving a wedge into the back cut, not by sawing through it .**

When the tree falls, step back and watch the crown.

Wait for the crown to stop swinging. Do not continue working under branches which have got stuck.

**Do not fell trees:**

- If you can longer distinguish details within the danger zone, e.g. owing to fog, rain, snow drifts or twilight.

- If the direction of fall cannot be reliably estimated owing to wind or gusts of wind. Felling work on sloping ground, black ice, frozen or dewy ground is safe only if you can get a firm foothold.

To switch off: Pull the plug out of the power socket.

To fell the tree, you must drive a wedge into the back cut. When retreating after making the back cut, watch out for falling branches.

## 11. Maintenance and cleaning

Always pull the plug out of the power socket before doing any work on the chainsaw!

Keep the cooling vents on the motor housing clean and unobstructed at all times. Only the maintenance work described in these operating instructions may be carried out. Any other maintenance work must be carried out by our Customer Service. Do not modify the power saw in any way as this could jeopardize its safety. Should the chainsaw fall despite our careful manufacturing and inspection procedures, have it repaired by an authorized Customer Service work-shop. In the event of any inquiries and spare parts orders, always quote the type designation and the parts number.

### Storage

**Keep your chain saw in a safe place.** The unused chainsaw should be stored clean, on a flat surface and in a dry place which is inaccessible to children

## 12. Trouble Shooting

The following table shows the types of breakdowns and indicates how you can correct it if your machine does not function correctly. If in spite of this, you do not manage to locate the problem and solve it, contact your after-sales service.

Caution: Before starting troubleshooting, stop the appliance and disconnect the power plug.

Problem	Cause	Solution
Motor does not run	No electricity	Check socket, cable and plug.
		Damaged cable: Have repaired by customer service. It is prohibited to patch the cable with insulating tape.
		Damaged switches have to be replaced by a Customer Service workshop.
	Chain brake	See section "chain brake" and "Releasing the chain brake"
	Running out of carbon brush	Change the carbon brush, ask a Customer Service workshop
Chain does not move	Chain brake	Check the chain brake, release if necessary.
Poor cutting performance	Blunt chain	Sharpen the chain
	Chain tension	Chain wrongly fitted
	Check that the chain is fitted correctly	Check the chain tension
Saw works only with difficulty Chain jumps off sword	Chain tension	Check the chain tension
Chain becomes hot	Chain lubrication	Check oil level
		Chain lubrication

## Parts Diagram and Parts List

## Parts Diagram and Parts List

No.	Description	No.	Description
1	Front Handle	21	Right Housing
2	Label 2	22	Carbon Brush Insert
3	Front Finger Guard	23	Field Insert
4	Washer1	24	Inner Connecting Wire4
5	Left Housing	25	Capacitor
6	Swiath Trigger	26	Inner Connecting Wire2
7	Brake Block	27	Inner Connecting Wire1
8	Screw	28	Inner Connecting Wire3
9	Rivet	29	Spring
10	Adjust Board	30	Pull Rod
11	Saw Chain	31	Switch
12	Guide Bar	32	Micro switch
13	Blade Cover	33	Supply Cord
14	Spiked Pumper	34	Cord Sheath
15	Retaining Spring	35	Screw
16	Washer2	36	Cord Clamp Plate
17	Sprocket	37	Terminal Board
18	Shield	38	Torsional Spring
19	Warning Label	39	Label
20	Screw		
<b>Motor ASSY</b>			
1	Carbon Brush Holder	15	Extension Spring
2	Bearing	16	Oil Pump Core
3	Carbon Brush Cover	17	O Type Ring
4	Carbon Brush	18	Oil Pump Sets
5	Armature	19	Screw
6	Woodruff Key	20	Oil Pipe 1
7	Field	21	Rubber Gasket
8	Wind Screen	22	Oil Pump Housing
9	Brake Wheel	23	Oil Pipe 2
10	Bearing	24	Washer3
11	Shaft Sleeve	25	Pin
12	Small Gear	26	Block
13	Extension Spring	27	Motor Holder
14	Hinge	28	Big Gear

## Parts Diagram and Parts List

No.	Description	No.	Description
29	Output Bearing	41	Oil Tank
30	Bearing	42	O Type Ring
31	Cover Board	43	Rubber Sheath On Oil Tank
32	Screw	44	Oil Tank Cap
33	Rubber Ring	45	Micro switch
34	Sheath On Oil Tank	46	Screw
35	Ring	47	Rubber Cork
36	Spring	48	Brake Belt
37	Filter Screen Stopper	49	Spring Washer
38	Shaft Sleeve	50	Washer
39	Bearing	51	Screw
40	Bolt	52	Field Bolt
<b>Quick Release ASSY</b>			
1	Knob2	6	Knob1
1-1	Nut	7	Label
2	Knob Cover Board	8	Chain Clamp Plate
3	Screw	9	Spiral Plate
4	Spring	10	Screw
5	Steel Ball		



