

EXCEL

18V Cordless Chainsaw 11783



INSTRUCTION MANUAL

DESCRIPTION OF THE SYMBOLS

Symbols are used in this manual to attract your attention to possible risks. The safety symbols and the explications which accompany them must be perfectly understood. The warning themselves do not prevent the risks and cannot be a substitute for proper methods of avoiding accidents.



Read instruction manual and safety instructions before starting up and pay attention!



These symbols indicate the requirement of wearing ear protection, eye protection, respirator and gloves when using the product.



Don't use your device in moisty weather.



Complies with relevant EU regulations.



Sound power level



Only for two-handed operation

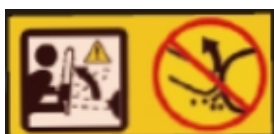

Attention! Kickback

Original Instructions

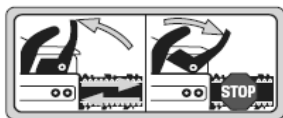

Make sure the “chain brake” is disengaged.



Recycle unwanted materials instead of disposing of them as waste. All tools, hoses and packaging should be sorted, taken to the local recycling centre and disposed of in an environmentally safe way.



Take the replaceable battery from the appliance before any extension, cleaning and servicing works.

On battery



Do not expose the battery to water



Do not expose the battery to fire or incinerate



max40°C Do not expose the battery to high temperatures (above 40°C)

On charger



Class II machine – Double insulation – You don't need any earthed plug.



Use this device indoors only.

GENERAL SAFETY WARNINGS

 **WARNING** Read all safety warnings and all instructions. Failure to follow the warnings and instructions may result in electric shock, fire and/or serious injury.

Save all warnings and instructions for future reference.

The term "power tool" in the warnings refers to your mains-operated (corded) power tool or battery-operated (cordless) power tool.

1) **Work area safety**

- a) **Keep work area clean and well lit.** Cluttered or dark areas invite accidents.
- b) **Do not operate power tools in explosive atmospheres, such as in the presence of flammable liquids, gases or dust.** Power tools create sparks which may ignite the dust or fumes.
- c) **Keep children and bystanders away while operating a power tool.** Distractions can cause you to lose control.

2) **Electrical safety**

- a) **Power tool plugs must match the outlet. Never modify the plug in any way. Do not use any adapter plugs with earthed (grounded) power tools.** Unmodified plugs and matching outlets will reduce risk of electric shock.
- b) **Avoid body contact with earthed or grounded surfaces, such as pipes, radiators, ranges and refrigerators.** There is an increased risk of electric shock if your body is earthed or grounded.
- c) **Do not expose power tools to rain or wet conditions.** Water entering a power tool will increase the risk of electric shock.
- d) **Do not abuse the cord. Never use the cord for carrying, pulling or unplugging the tool. Keep cord away from heat, oil, sharp edges or moving parts.** Damaged or entangled cords increase the risk of electric shock.
- e) **When operating a power tool outdoors, use an extension cord suitable for outdoor use.** Use of a cord suitable for outdoor use reduces the risk of electric shock.
- f) **If operating a power tool in a damp location is unavoidable, use a residual current device (RCD) protected supply.** Use of an RCD reduces the risk of electric shock.

3) **Personal safety**

- a) **Stay alert, watch what you are doing and use common sense when operating a power tool. Do not use a power tool while you are tired or under the influence of drugs, alcohol or medication.** A moment of inattention while operating power tools may result in serious personal injury.

Original Instructions

- b) **Use personal protective equipment. Always wear eye protection.** Protective equipment such as dust mask, non-skid safety shoes, hard hat, or hearing protection used for appropriate conditions will reduce personal injuries.
 - c) **Prevent unintentional starting. Ensure the switch is in the off-position before connecting to power source and/or battery pack, picking up or carrying the tool.** Carrying power tools with your finger on the switch or energising power tools that have the switch on invites accidents.
 - d) **Remove any adjusting key or wrench before turning the power tool on.** A wrench or a key left attached to a rotating part of the power tool may result in personal injury.
 - e) **Do not overreach. Keep proper footing and balance at all times.** This enables better control of the power tool in unexpected situations.
 - f) **Dress properly. Do not wear loose clothing or jewellery. Keep your hair, clothing and gloves away from moving parts.** Loose clothes, jewellery or long hair can be caught in moving parts.
 - g) **If devices are provided for the connection of dust extraction and collection facilities, ensure these are connected and properly used.** Use of dust collection can reduce dust-related hazards.
- 4) **Power tool use and care**
- a) **Do not force the power tool. Use the correct power tool for your application.** The correct power tool will do the job better and safer at the rate for which it was designed.
 - b) **Do not use the power tool if the switch does not turn it on and off.** Any power tool that cannot be controlled with the switch is dangerous and must be repaired.
 - c) **Disconnect the plug from the power source and/or the battery pack from the power tool before making any adjustments, changing accessories, or storing power tools.** Such preventive safety measures reduce the risk of starting the power tool accidentally.
 - d) **Store idle power tools out of the reach of children and do not allow persons unfamiliar with the power tool or these instructions to operate the power tool.** Power tools are dangerous in the hands of untrained users.
 - e) **Maintain power tools. Check for misalignment or binding of moving parts, breakage of parts and any other condition that may affect the power tool's operation. If damaged, have the power tool repaired before use.** Many accidents are caused by poorly maintained power tools.
 - f) **Keep cutting tools sharp and clean.** Properly maintained cutting tools with sharp cutting edges are less likely to bind and are easier to control.

Original Instructions

- g) **Use the power tool, accessories and tool bits etc. in accordance with these instructions, taking into account the working conditions and the work to be performed.** Use of the power tool for operations different from those intended could result in a hazardous situation.
- 5) **Service**
- a) **Have your power tool serviced by a qualified repair person using only identical replacement parts.** This will ensure that the safety of the power tool is maintained.
 - b) **Caution!** If the replacement of the supply cord is necessary, this has to be done by the manufacturer or his agent in order to avoid a safety hazard.

Battery tool use and care

- a) **Recharge only with the charger specified by the manufacturer.** A charger that is suitable for one type of battery pack may create a risk of fire when used with another battery pack.
- b) **Use power tools only with specifically designated battery packs.** Use of any other battery packs may create a risk of injury and fire.
- c) **When battery pack is not in use, keep it away from other metal objects like paper clips, coins, keys, nails, screws, or other small metal objects, that can make a connection from one terminal to another.** Shorting the battery terminals together may cause burns or a fire.
- d) **Under abusive conditions, liquid may be ejected from the battery; avoid contact. If contact accidentally occurs, flush with water. If liquid contacts eyes, additionally seek medical help.** Liquid ejected from the battery may cause irritation or burns.
- e) **Do not use a battery pack or tool that is damaged or modified.** Damaged or modified batteries may exhibit unpredictable behaviour resulting in fire, explosion or risk of injury.
- f) **Do not expose a battery pack or tool to fire or excessive temperature.** Exposure to fire or temperature above 130 °C may cause explosion.

Follow all charging instructions and do not charge the battery pack or tool outside the temperature range specified in the instructions. Charging improperly or at temperatures outside the specified range may damage the battery and increase the risk of fire.

SAFETY INSTRUCTION FOR BATTERY CHARGER

⚠ WARNING! Read all safety warnings and all instructions. Failure to follow the warnings and instructions may result in electric shock, fire and/or serious injuries. Save all warnings and

Original Instructions

instructions for future reference. Before using the battery charger, read and follow:

- these operating instructions,
- the currently valid site rules and the regulations for the prevention of accidents. This charger is not intended for use by children and persons with physical, sensory or mental limitations or a lack of experience or knowledge. This charger can be used by children aged 8 or older and by persons who have physical, sensory or mental limitations or a lack of experience or knowledge if they have been supervised or instructed in the safe operation of the charger and understand the associated dangers. Otherwise, there is a danger of operating errors and injuries. Supervise children. This will ensure that children do not play with the charger.
- Cleaning and user maintenance of the battery charger shall not be made by children without supervision.
- If the supply cord is damaged, it must be replaced by the manufacturer, its service agent or similarly qualified persons in order to avoid a hazard.

- **Keep the battery charger away from rain or moisture.** Penetration of water in the battery charger increases the risk of an electric shock.
- **Keep the battery charger clean.** Contamination can lead to danger of an electric shock.
- **Before each use, check the battery charger, cable and plug. If damage is detected, do not use the battery charger. Never open the battery charger yourself. Have repairs performed only by a qualified technician and only using original spare parts.** Damaged battery chargers, cables and plugs increase the risk of an electric shock.
- **Do not place any objects on the battery charger and do not place the battery charger on soft surfaces. This is a risk of fire.**
- **Always check that the mains voltage matches the voltage indicated on the rating plate of the battery charger.**
- **Never use the charger if cable, plug or the unit itself has been damaged by external influences.** Take the charger to the nearest service centre.
- **Never open the battery charger.**

SAFETY INSTRUCTION FOR BATTERY

a) Recharge only with the charger specified by the manufacturer. A charger that is suitable for one type of battery pack may create a risk of fire when used with another battery pack.

Original Instructions

b) Use power tools only with specifically designated battery packs. Use of any other battery packs may create a risk of injury and fire.

c) When battery pack is not in use, keep it away from other metal objects, like paper clips, coins, keys, nails, screws or other small metal objects, that can make a connection from one terminal to another. Shorting the battery terminals together may cause burns or a fire.

d) Under abusive conditions, liquid may be ejected from the battery; avoid contact. If contact accidentally occurs, flush with water. If liquid contacts eyes, additionally seek medical help. Liquid ejected from the battery may cause irritation or burns.

e) Have your power tool serviced by a qualified repair person using only identical replacement parts. This will ensure that the safety of the power tool is maintained.

WARNING! During the use of tools supplied with batteries, the basic safety measures must be followed in order to reduce fire hazards, electrolyte leakage and personal injury, including the following precautions:

- Ensure that the battery block is suitable for the tool.
- Ensure that outside surface of the battery block is clean and dry before connecting it to the charger.
- Ensure that the batteries are charged using the correct charger recommended by the manufacturer. Incorrect use can create a risk of electric shock, overheating or the leaking of corrosive liquid from the battery.
- If there is an electrolyte leak, avoid any contact with the skin. In the event of a leak, wipe with a rag. If the liquid comes into contact with the skin, rinse abundantly with water. In the event of a reaction or contact with the eyes or mucous membranes, consult a doctor.

- Ensure that the appliance is properly switched off before inserting the battery into the appliance. Inserting a battery into an appliance while it is switched on can cause accidents.
- Use the appliance only with the type of battery indicated in the instructions. Using another type of battery can create a serious risk of injury and cause a fire.
- When the battery is not in use, keep it away from metal objects such as trombones, coins, keys or other small metal objects that can create a connection between one terminal and the other. Short-circuiting the terminals of batteries can cause burns to the user and cause a fire.
- Dispose of batteries. Ensure that the battery is properly disposed of:

Original Instructions

- 1- Do not throw it away
- 2- Do not to burn it
- 3- Do not throw it in a river
- 4- Dispose of it in the designated collection containers (ask your retailer)

ADDITIONAL SAFETY WARNINGS FOR BATTERY

- a. Do not connect the positive terminal and negative terminal of the battery to each other with any metal object (such as wire).
- b. Do not carry or store battery together with necklaces, hairpins or other metal objects.
- c. Do not pierce the battery with nails, strike the battery with a hammer, step on the battery or otherwise subject it to strong impacts or shocks.
- d. Do not solder directly onto the battery.
- e. Do not expose battery to water or salt water, or allow the battery to get wet.
- f. Do not disassemble or modify the battery.
- g. Do not place the battery in or near fire, on stoves or other high temperature locations. Do not place the battery in direct sunlight, or use or store the battery inside cars in hot weather.
- h. Do not place the battery in microwave ovens, high-pressure containers or on induction cookware.
- i. If you intend to store a battery for a period without use then store battery at room temperature (19°C to 25°C), charged to about 30 – 50% of capacity. When storing for very long periods boost charge the battery once per year to prevent over discharge.

SPECIFIC TOOL SAFETY WARNINGS

- **Keep all parts of the body away from the saw chain when the chain saw is operating. Before you start the chain saw, make sure the saw chain is not contacting anything.** A moment of inattention while operating chain saws may cause entanglement of your clothing or body with the saw chain.
- **Always hold the chain saw with your right hand on the rear handle and your left hand on the front handle.** Holding the chain saw with a reversed hand configuration increases the risk of personal injury and should never be done.
- **Hold the tool by insulated gripping surfaces only, because the saw chain may contact hidden wiring or its own cord.** Saw chains contacting a "live" wire may make exposed metal parts of the tool "live" and could give the operator an electric shock.
- **Wear safety glasses and hearing protection. Further protective equipment for head, hands, legs and feet is recommended.** Adequate

Original Instructions

protective clothing will reduce personal injury by flying debris or accidental contact with the saw chain.

- **Do not operate a chain saw in a tree.** Operation of a chain saw while up in a tree may result in personal injury.
- **Always keep proper footing and operate the chain saw only when standing on fixed, secure and level surface.** Slippery or unstable surfaces such as ladders may cause a loss of balance or control of the chain saw.
- **When cutting a limb that is under tension be alert for spring back.** When the tension in the wood fibers is released the spring loaded limb may strike the operator and/or throw the chain saw out of control.
- **Use extreme caution when cutting brush and saplings.** The slender material may catch the saw chain and be whipped toward you or pull you off balance.
- **Carry the chain saw by the front handle with the chain saw switched off and away from your body. When transporting or storing the chain saw always fit the guide bar cover.** Proper handling of the chain saw will reduce the likelihood of accidental contact with the moving saw chain.
- **Follow instructions for lubricating, chain tensioning and changing accessories.** Improperly tensioned or lubricated chain may either break or increase the chance for kickback.
- **Keep handles dry, clean, and free from oil and grease.** Greasy, oily handles are slippery causing loss of control.
- **Cut wood only. Do not use chain saw for purposes not intended. For example: do not use chain saw for cutting plastic, masonry or non-wood building materials.** Use of the chain saw for operations different than intended could result in a hazardous situation.

Causes and operator prevention of kickback:

Kickback may occur when the nose or tip of the guide bar touches an object, or when the wood closes in and pinches the saw chain in the cut.

Tip contact in some cases may cause a sudden reverse reaction, kicking the guide bar up and back towards the operator.

Pinching the saw chain along the top of the guide bar may push the guide bar rapidly back towards the operator.

Either of these reactions may cause you to lose control of the saw which could result in serious personal injury. Do not rely exclusively upon the safety devices built into your saw. As a chain saw user, you should take several steps to keep your cutting jobs free from accident or injury.

Kickback is the result of tool misuse and/or incorrect operating procedures or conditions and can be avoided by taking proper precautions as given below:

- **Maintain a firm grip, with thumbs and fingers encircling the chain saw handles, with both hands on the saw and position your body and arm**

Original Instructions

to allow you to resist kickback forces. Kickback forces can be controlled by the operator, if proper precautions are taken. Do not let go of the chain saw.

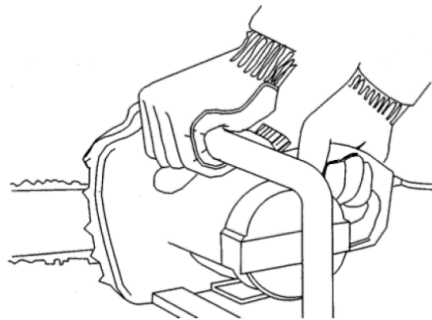

- **Do not overreach and do not cut above shoulder height.** This helps prevent unintended tip contact and enables better control of the chain saw in unexpected situations.
- **Only use replacement bars and chains specified by the manufacturer.** Incorrect replacement bars and chains may cause chain breakage and/or kickback.
- **Follow the manufacturer's sharpening and maintenance instructions for the saw chain.** Decreasing the depth gauge height can lead to increased kickback.
- The first time user should request an experienced operator in the use of the chainsaw and the protective equipment, and should have the initial practice cutting logs on a saw horse or cradle.
- In the interest of personal safety it is highly recommended: when using the chain saw always use it with a residual current device (RCD) with a tripping current of 30 mA or less.
- Position the cord so that it will not be caught on branches and the like, during cutting.

Attention for usage of electric chain saw

- Before any cutting, you must wait for the saw chain running to reach a stable speed.
- When cutting wood, please do not press the chain saw with big force.
- During cutting, if the saw chain is stuck in the wood, please stop the saw immediately, and take the saw out of the wood carefully. Restart the saw till the saw chain reaches a stable speed, and then recut again.
- Operate the machine properly, activate the trigger completely during use. And do not work continuously for a long time to avoid overuse fatigue.

Original Instructions

Important safety

- How to read symbols



! WARNING

- 1 Avoid bar nose contact.
- 2 Beware of kick back.
- 3 Do not attempt to hold saw with one hand.
- 4 Recommended cutting procedure. Hold saw properly with both hands.

INTENDED USE

This device is specifically intended for sawing wood and felling trees in private areas, unsuitable for sawing plastic, masonry or construction materials that are not made of wood, intended for use in accordance with the descriptions and safety instructions in this operating manual.

The equipment is to be used only for its prescribed purpose. Any other use is deemed to be a case of misuse. The user / operator and not the manufacturer will be liable for any damage or injuries of any kind caused as a result of this. The user is liable for all injuries to third parties and damage to their property.

Please note that our equipment has not been designed for use in commercial, trade or industrial applications. Our warranty will be voided if the machine is used in commercial, trade or industrial businesses or for equivalent purposes.

TECHNICAL SPECIFICATIONS

Product name	18V Cordless chain saw
Model	11783
Rated voltage	18VDC
Rated no load speed of motor.	3000/min
Chain speed	5.6m/s
Max cutting length	245mm
Oil tank	220ml
L _{pA} sound pressure level	86.2 dB(A) K _{pA} =3 dB(A)
L _{WA} sound power level measured	95.0 dB(A)
L _{WA} sound power level guaranteed	98.0 dB(A)
K _{WA} uncertainty	2.66 dB(A)
Vibration emission value ah	Front handle:4.5m/s ² ,rear handle:5.0m/s ²
K uncertainty	1,5 m/s ²
Battery and Charger	
Recommended battery	11759 Li-ion 18V d.c. 5.0Ah
Recommended charger	Model : 11761 Input : 100-240V~ 50Hz 60W Output : 20V DC 2.3A Charging time : 140MIN
	Model :11763 Input : 100-240V~ 50Hz 125W Output : 20VDC, 5A Charging time : 70 MIN
	Model :11762 Input : 100-240V~ 50Hz 130W Output : 20VDC, 2.3AX2, USB×2, 5VDC MAX 2A Charging time : 140MIN

Sound and vibration

Measured sound values determined according to EN 60745-2-13:2009+A1:2010.

Vibration total values (triax vector sum) determined according to EN 60745-2-13:2009+A1:2010.

The vibration emission level given in this information sheet has been

Original Instructions

measured in accordance with a standardised test given in EN 60745-2-13:2009+A1:2010 and may be used to compare one tool with another.

It may be used for a preliminary assessment of exposure.

The declared vibration emission level represents the main applications of the tool. However if the tool is used for different applications, with different accessories or poorly maintained, the vibration emission may differ. This may significantly increase the exposure level over the total working period.

An estimation of the level of exposure to vibration should also take into account the times when the tool is switched off or when it is running but not actually doing the job. This may significantly reduce the exposure level over the total working period.

Identify additional safety measures to protect the operator from the effects of vibration such as: maintain the tool and the accessories, keep the hands warm, organisation of work patterns.

Keep the noise emissions and vibrations to a minimum.

- Only use appliances which are in perfect working order.
- Service and clean the appliance regularly.
- Adapt your working style to suit the appliance.
- Do not overload the appliance.
- Have the appliance serviced whenever necessary.
- Switch off the tools when it is not in use.
- Wear protective gloves.

LIST OF MAIN PARTS

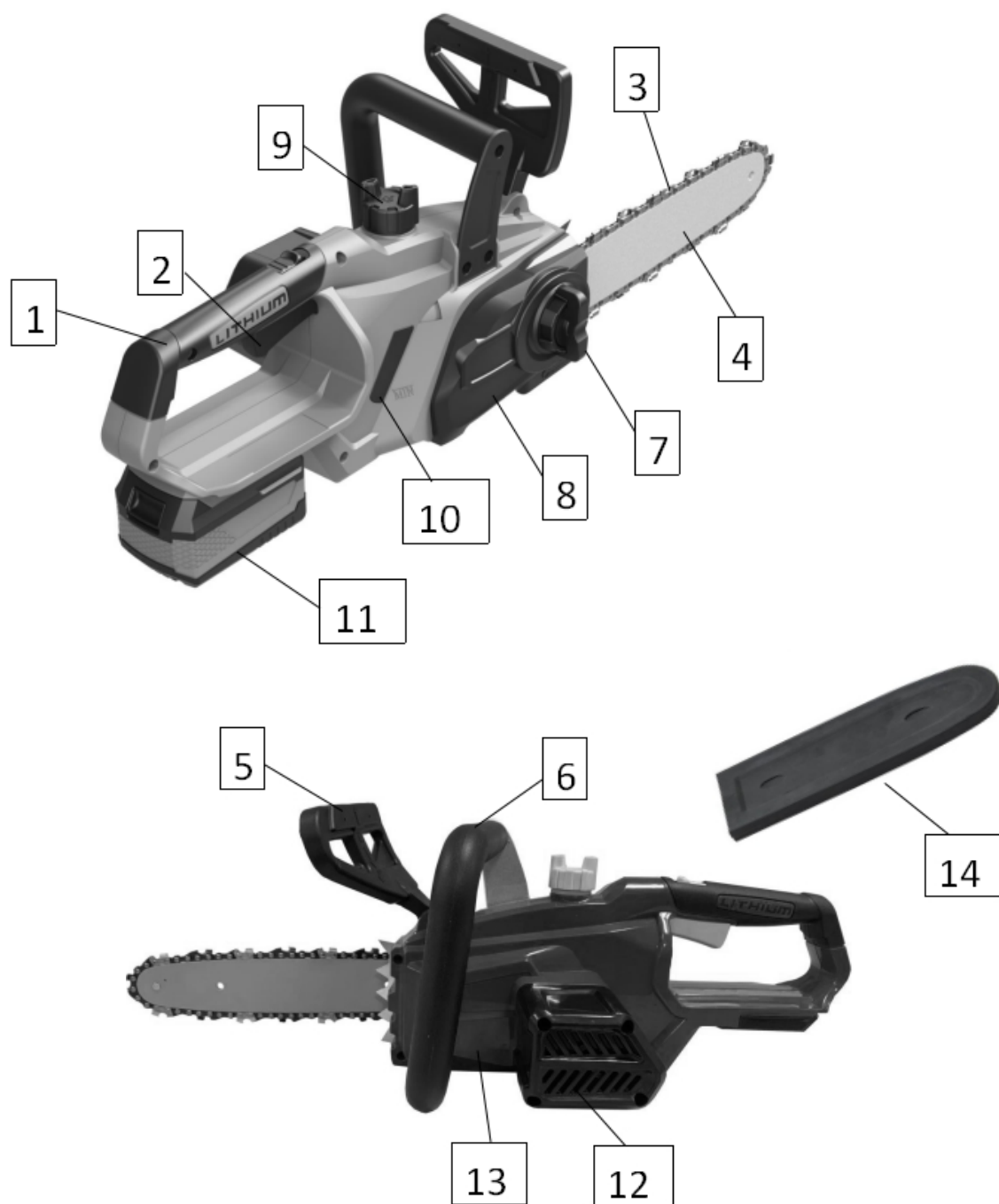

1.Rear handle	2.ON/OFF switch
3.Saw chain	4.Guide bar
5.Hand guard/chain brake	6.Front handle
7.Chain tensioning wheel	8.Chain cover
9.Oil tank cap	10.Oil tank
11.Battery pack (excluded)	12.Ventilation openings
13.Housing	14.Bar cover

Before using the equipment

Battery charger (Fig.1)

The lithium-ion battery can be charged at any time and will not develop a “memory” when charged after only a partial discharge. It is not necessary to run down the battery pack charge before recharging. Remove the battery pack from the tool when convenient for you and your job. You can “top-off” your battery pack’s charge before starting a big job or long period of use.

Due to lithium-ion’s fade-free properties, the only time it is necessary to charge the lithium-ion battery pack is when the pack has reached the end of its charge. To signal the end of charge, power to the tool will drop quickly. Charge the battery pack as needed.



11761

11763

11762

a. Charging the battery

This lithium-ion battery pack is shipped partially charged. Before using it the first time, fully charge the battery pack. A fully discharged battery pack with a temperature between 5°C and 35°C will charge in about 70-140MIN(See section”Specifications”).

11761:

- Plug the charger adapter into power source. The green light on the charger stand will illuminate, indicating the charger is powered.
- Slide the battery all the way into the charger stand until it locks in place with a click. The red light on the charger stand will illuminate, indicating that the battery is charging.
- The red light will go off after charging is complete and a green light will appear.

11763/11762:

See the manual of 11763/11762

NOTE: Batteries may become warm while charging. This is normal. If the battery is hot after continuous use in the tool, allow it to cool down to room temperature before charging. This will extend the life of your batteries.

Original Instructions

WARNING: Always disconnect the battery pack from the tool before any assembly, adjustments or changing accessories.

b. Insertion and removal of rechargeable battery (Fig.2)

Depress the battery-release button located on the front of the battery pack to release battery pack.

Pull the battery pack out and remove it from the tool.



Fig.2

Warning!

Always remove the battery pack before making adjustments to the equipment.

Be sure to read the following information before you put the cordless equipment into operation:

- Charge the battery pack with the charger. An empty battery pack requires a charging period of approximately 0.5 to 1 hour.

Chain saw assembly

⚠ Note: After unpacking, check the contents for completeness and possible transport damage. If a part is missing or damaged, please contact the seller.

- Open the packaging and remove the device carefully.
- Remove the packaging material as well as the packaging and transport bracing (if available).
- Check that the delivery is complete.
- Check the device and accessory parts for transport damage.
- If possible, store the packaging until the warranty period has expired.

Original Instructions

Installation: Installing the guide bar and saw chain

⚠️ WARNING!

- The teeth of the saw chain are very sharp! Protective gloves must be worn during all work on the chain.

Risk of injury!

- An incorrectly installed saw chain leads to uncontrolled cutting behaviour by the device! When fitting chain, observe the prescribed running direction!

- Place the chainsaw on a level surface.

1. Release the handwheel and take off the chain cover.



2. Place the saw chain around the guide bar, starting at the top section of the bar. Insert the saw chain in the circumferential groove. **When inserting the chain, observe the correct running direction of the chain**



3. Place the guide bar with the elongated hole on the stud bolt and guide bolt on the chainsaw.

Run the saw chain around the chain wheel.

Original Instructions





4. (1) Put the the chain cover's sign  and the adjust knob's sign  in the Vertical alignment.(Fig.1)
- (2) Fit the chain cover. Tighten the handwheel clockwise for fastening the rail and chain cover.(Fig.2)
- (3) The adjust knob adjusting the chain tension.(Fig. 3)
The saw chain must not sag, although it should be possible to pull it 1-2 millimetres away from the guide bar in the centre of the guide bar.



Fig.1



Fig.2



Fig. 3

Before starting the equipment

⚠ Caution! Do not fit the battery until the equipment has been fully assembled and all the settings have been actuated. Always wear protective gloves when working on the equipment to protect yourself against injury. Carefully unpack all parts and check that they are complete.

⚠ NOTE: The tension of a new chain must be checked after a few minutes in operation, and adjusted if necessary. To do so switch the device off. Remove the battery and apply the chain brake.

Filling with chain oil

⚠ CAUTION!

- Only add environmentally friendly, good quality chain lubricating oil to the chain saw.
- Do not add used oil. Used oil can cause skin cancer with extended and repeated skin contact, and is damaging to the environment! Used oil does not have the necessary lubricating characteristics and is unsuitable for chain lubrication.
- An oil other than the recommended oil can cause damage to the rail, chain and lubrication system.
- Make sure that no dirt gets into the oil tank.
- Avoid oil spillages. Always wipe up spilled oil.
- Unscrew the oil tank cap.
- Carefully add the chain lubricating oil until it reaches the top mark on the oil level indicator. Oil tank capacity: max. 220 ml
- Screw the oil tank cap on tightly by hand.



Commissioning Chain brake

⚠ WARNING!

Always check that the chain brake is working properly before use. If not, do not use the chainsaw and have it repaired by a qualified specialist or a specialist workshop.

The chain saw is equipped with protective equipment activated by a chain brake, which brings the chain to a standstill within a fraction of a second in the event of kickback. With kickback, the chain brake will be triggered automatically through the contact of the hand guard with the left hand.

Therefore, always hold the chainsaw tight in both hands.

Manual activation of the chain brake

- Tilt the hand guard in the direction of the guide bar tip.



Releasing the chain brake

- Draw the hand guard in the direction of the bow-type handle.



Checking the chain brake

- Set the chainsaw down on a firm surface.
- Release the chain brake.
- Hold the chainsaw tight in both hands.
- Switch the chainsaw on. The chainsaw starts running.
- Tilt the hand guard in the direction of the guide bar tip. The chain must come to an immediate standstill! If not, do not use the chainsaw and have it repaired by a qualified specialist or a specialist workshop.
- After work, regularly clean the visible mechanisms of the chain brake to remove chips and sawing residues.

Chain lubrication

⚠ CAUTION! The device must only be operated with sufficient chain lubricating oil. Insufficient lubrication reduces the service life of the device.

- Check the oil level on the basis of the oil level indicator.

Refilling the chain oil

⚠ CAUTION!

- Only add environmentally friendly, good quality chain lubricating oil to the chain saw.
- Do not add used oil. Used oil can cause skin cancer with extended and repeated skin contact, and is damaging to the environment! Used oil does not have the necessary lubricating characteristics and is unsuitable for chain lubrication.
- An oil other than the recommended oil can cause damage to the rail, chain and lubrication system.
- Make sure that no dirt gets into the oil tank.

Original Instructions

- Avoid oil spillages. Always wipe up spilled oil.

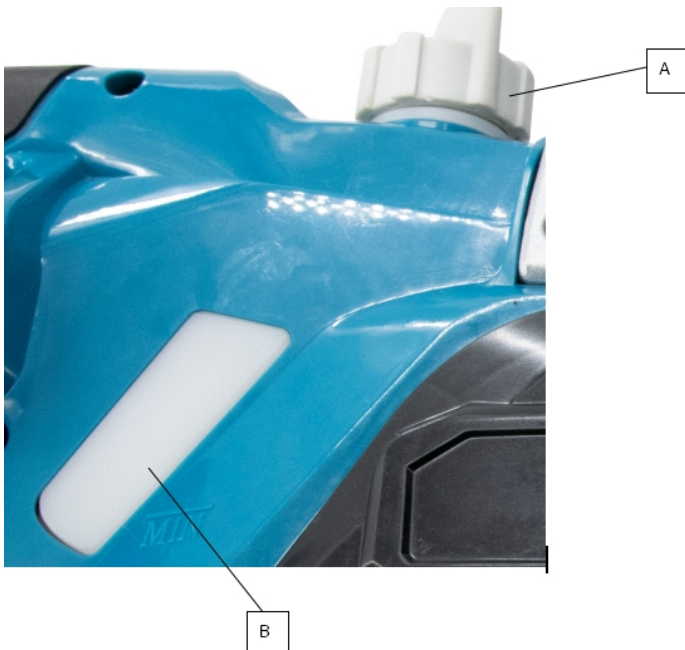

- Check the oil level indicator (B) to make sure sufficient chain oil is available for lubrication.
- Unscrew the oil tank cap (A). Before opening, clean the tank cover and filling nozzle if necessary.
- Carefully add the chain lubricating oil until it reaches the top mark on the oil level indicator (B).

Checking the chain lubrication

- Start the device (see section “Switching on and off”).
- Hold the running saw chain approx. 15 cm above a suitable surface for a short time. With sufficient chain lubrication, a light track will appear due to the oil sprayed from the saw chain.

Switching on the device

⚠ WARNING! Make sure the saw chain is not yet applied to the cut and that no other objects are touched. Risk of injury!

- Hold the chainsaw firmly with both hands and make sure that no persons (in particular children) or animals are in the immediate vicinity.
- Make sure that the chain brake is released before starting the chainsaw. To do so, draw the hand guard back in the direction of the bow-type handle.

Original Instructions



- Press and hold down the switch lock (1).
- Press the on/off switch(2). The chainsaw starts running.



- Release the switch lock(1) again.

Switching off the device:

- Release the on/off(2) switch.

⚠ Caution! In an emergency, stop the machine by releasing the on/off switch

OPERATION

⚠ ATTENTION! Do not operate the chainsaw with a defective or badly worn cutting device.

⚠ WARNING! Familiarize yourself with the chainsaw sawing technique in detail before use (see “Basic working technique”).

Original Instructions

Risk of injury! Never allow children to operate the chainsaw. Do not allow persons to use the chainsaw, if they have not read the operating manual or received appropriate instructions for the safe and correct use of the chainsaw.

We recommend attending a suitable training course. The information provided here is for supplementary purposes only!

Before every use

- Check all parts are secure and inspect for visible defects.
- Check the device for correct chain tension.
- Test the function of the chain brake.
- Check chain lubrication.
- Check for any leaks.

Holding the device correctly

⚠ Risk of injury!

- Never work on unstable ground!
- Never work above shoulder height!
- Never work when standing on ladders!
- Do not bend too far when working!
- Only use the device when the weather and terrain conditions are favourable!
- Stands with both legs firmly on the grounds.
- Be aware of obstacles in the working area.
- During work, always hold the device tight in both hands!

How to saw correctly!

- Scan the working area and remove any interfering objects.
- At the start of work, check that the device is safe.
- Hold the device in both hands as prescribed.
- Switch on the chainsaw before applying it to the cut.
- Exert regular pressure on the device and do not apply excessive force.
- If possible, apply the device to the branch you wish to saw with the claw stop.

⚠ ATTENTION!

If the cutting device touches a foreign body, or the operation noise intensifies, or the device vibrates unusually heavily, switch off the motor and allow the device to come to a halt. Remove the battery and implement the following measures:

- check for damage
- check for loose parts and fasten all parts
- replace damaged parts with equivalent parts or have them repaired.

AFTER USE

⚠ Risk of injury!

Always switch off the device before setting the device down. The saw

Original Instructions

chain will run on for a short time after stop the motor, wait until all moving parts have come to a complete standstill, remove battery, place the protective sheath on the cutting unit, apply chain brake, leave the device to cool down.

⚠ NOTE: After use, the battery temperature might be high, and the battery would be over-temperature protected, allow the battery cool down for half an hour and it would recovery function.

Basic working technique

⚠ Risk of injury! This section examines the basic working technique for using the device. The information provided here does not replace the many years of training and experience of a specialist. Avoid any work that you are not adequately qualified for! Careless use of the device can lead to serious injuries and even death!

Sawing technique: Pull sawing

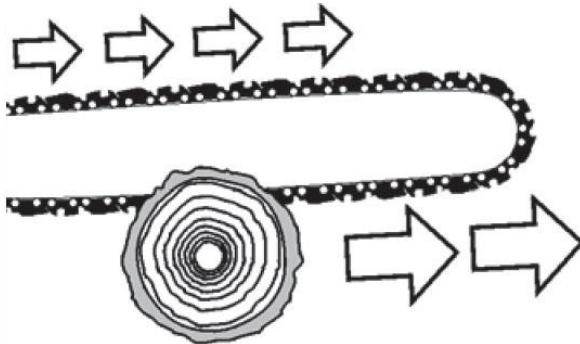

With this technique, sawing takes place with the underside of the guide bar from top to bottom.

The saw chain pulls the device forwards and away from the user. With this action, the front edge of the device forms a support, which absorbs the forces that arise on the tree trunk during sawing. With pull sawing, the user has significantly greater control over the device and is able to better avoid kickbacks. This sawing technique should therefore be used if possible.

Push sawing

With this technology, sawing takes place with the top side of the guide bar from bottom to top. The saw chain pushes the device backwards, towards the user.

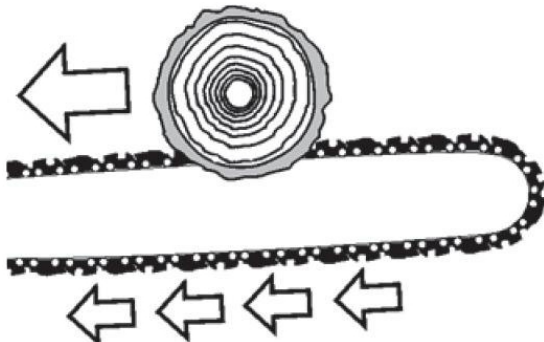

Original Instructions

⚠️ WARNING!

If the guide bar tilts, the device may be jerked towards the user with great force. If the user does not balance the backward force of the saw chain with their body strength, there is a risk that only the tip of the guide bar will remain in contact with the wood and kickback will occur.

⚠️ Risk of death or serious injuries!

Felling a tree

⚠️ Risk of injury!

Felling and branch removal work may only be performed by trained personnel! There is a risk of life threatening injuries!

Before starting felling work, make sure that:

- no bystanders or animals are in the felling area (A).
- a clear evacuation route, free of obstacles, is available to all participants.

Withdrawal (B) takes place at an oblique angle to the felling direction.

- the area around the trunk is clear of obstacles (risk of tripping!).
- the nearest workplace is at least 2½ trunk lengths away. Before felling, check the felling direction of the tree and make sure that no obstacles, persons or animals are within a distance of 2½ tree lengths.

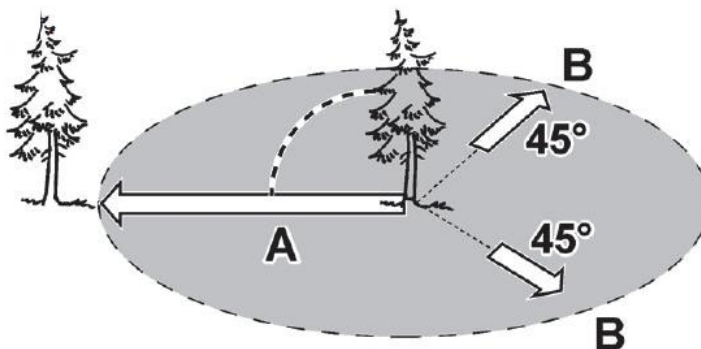

Tree felling takes place in two steps:

- Saw a felling sink in the trunk of around one third of its diameter, on the side of the felling direction (1).
- On the opposite side (2) make the felling cut, which must be slightly higher than the felling sink (approx. 3–5 cm).

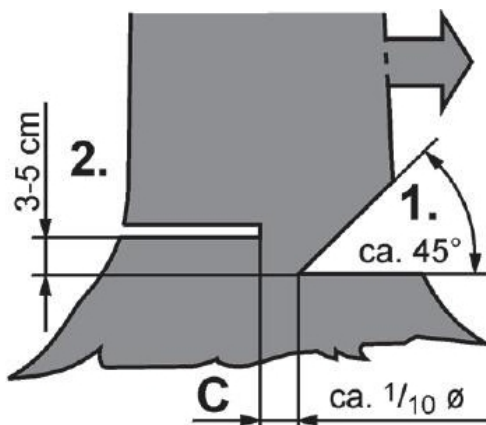

Original Instructions

Risk of injury!

Never saw fully through the trunk. The area (C) serves as a “hinge” and ensures the correct felling direction.

During felling, only stand to the side of the tree you intend to fell! There is a risk of life-threatening injuries!

Trunks lying flat on the grounds

- Cut around halfway through the trunk, then turn it over and saw through the (⚠)r side.

Damage to the device! Ensure that the guide bar does not come into contact with the ground when sawing through a tree trunk!

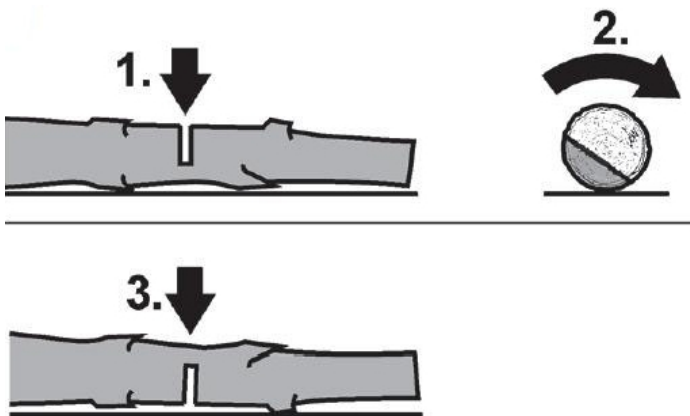

Fallen trunks

We recommend supporting trunks on a sawhorse when sawing through them. If this is not possible, the trunk should be lifted with the aid of supporting boughs or with support blocks and supported.

In area A first cut around one third of the trunk diameter from top to bottom, and then make the subsequent cut from bottom to top; In area B first cut around one third of the trunk diameter from bottom to top, and then saw through from the top.

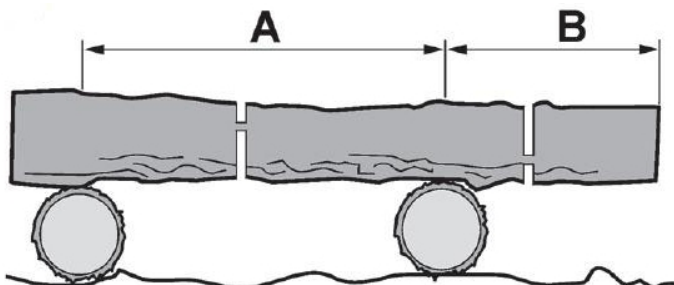

⚠ Risk of injury!

Do not saw trunks that are strained! Splitting wood or a tilted guide bar can result in serious injuries!

Original Instructions

Removing branches

- Always work on the side opposite the respective branch.
 - Start at the bottom of the branch and work up.
 - Saw into the branch 10–15 cm from the branch base from bottom to top, to 1/3 of the branch diameter (1).
 - Saw through the branch slightly further out from top to bottom (2).
 - Perform a cut tightly against the trunk (3). Make the cut from top to bottom.
- During delimiting always saw off the branches that project freely in the air first. Only lop off support limbs once the branches have been sawn along their length.

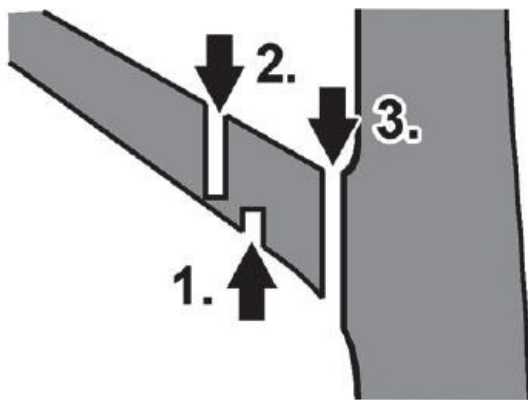

⚠ Risk of injury!

With branches that are supported or strained, the saw chain can wedge in the wood!

MAINTENANCE

⚠ WARNING!

Always remove the battery from the device before all work on the device.
Danger of injury due to the sharp cutting teeth! Wear safety gloves.

⚠ In the interest of your safety!

Only perform the maintenance work described here yourself. All other work - in particular motor maintenance and repairs - must be performed by a qualified specialist. Unprofessional work can lead to device damage and therefore also to injuries.

Cleaning and maintenance

After every use, clean the device.

Regularly, depending on the conditions of use:

- Re-tighten the saw chain.
- Clean guide bar oil guide groove.
- Sharpen the saw chain.
- Check the saw chain oil level, top up if necessary.

Original Instructions

Cleaning

⚠ WARNING! Do not use water or liquid cleaning products.

⚠ CAUTION! Clean the device after every use. An unclean device will lead to material damage and malfunctions.

- Use a damp cloth and a soft brush to clean the device.
- Take off the chain over and then remove the deposits on the guide rail, saw chain, chain wheel and chain cover with a soft brush.
- Keep the ventilation slots clean and free of dust.

Re-tightening the saw chain

The saw chain must not sag, although it should be possible to pull it 1-2 mm away from the guide bar in the centre of the guide bar. Turn the hand wheel anticlockwise, sufficiently that the guide bar can be moved by hand.

- Turn the chain tensioning wheel, so that the chain is tensioned.
- Turn the saw chain by hand, to check it runs freely. It must glide freely in the rail.
- Tighten the hand wheel for fastening the rail and chain cover.

NOTE

The tension of a new chain must be checked after a few minutes in operation, and adjusted if necessary.

Cleaning the guide bar oil guide groove

- Dismantle the guide bar.
- Clean the oil guide groove of dirt with a suitable tool.
- Use a plastic spatula, do not use steel tools!
- Refit the guard bar.

Sharpening the saw chain

Special tools are required to sharpen the saw chain; these ensure that the chain cutting edges are sharpened at the correct angle and to the correct depth.

We recommend having the saw chain sharpened by a specialist.

TROUBLESHOOTING GUIDE

Fault	Possible cause	Remedy
The equipment does not work	Battery empty	Charge battery
	Battery is not correctly inserted	Remove battery and insert again
Equipment operates intermittently	Loose connection (external)	Consult a specialist workshop.
	Loose connection (internal)	
	ON/OFF switch defective	
Saw chain is dry	No oil in the tank	Top up with oil
	Vent in the oil tank cap is blocked	Clean the oil tank cap
	Oil outlet is blocked	Clear the oil outlet
Chain/guide bar is hot	No oil in the tank	Top up with oil
	Vent in the oil tank cap is blocked	Clean the oil tank cap
	Oil outlet is blocked	Clear the oil outlet
	Chain is blunt	Re-sharpen or replace the chain
	Chain is over tensioned	Check the chain tension
Chainsaw judders, vibrates or does not saw properly	Chain is under tensioned	Adjust the chain tension
	Chain is blunt	Re-sharpen or replace the chain
	Chain is worn	Replace the chain
	Saw teeth point in the wrong direction	Refit the chain with the teeth facing in the correct direction

STORAGE

• Empty the oil

1. Screw off the oil tank cap.
2. Drain oil into a container thoroughly.
3. Reinstall the oil tank cap.

- Store the machine, operating instructions and where necessary the accessories in the original packaging. In this way you will always have all the information and parts ready to hand.

- Pack the device well or use the original packaging in order to avoid transit damage.

- Store the machine in dry and well ventilated surroundings and with the oil tank empty.

- Store the battery and the device separately from each other.

- Charge the battery before storing it for the winter.

- In case of longer breaks between use, always drain the chain lubricating oil from the device.

Original Instructions

- Place the protective sheath on the cutting unit.
- Keep the device, and its plastic components in particular, always from brake fluid, products containing oil, penetrating oil etc. They contain chemical substances that may damage or destroy the plastic parts of the device.
- Fertilizers and other garden chemicals contain substances which can have a heavily corrosive effect on metal parts. Do not store the device close to the substances.

Disposal and recycling

The equipment is supplied in packaging to prevent it from being damaged in transit. The raw materials in this packaging can be reused or recycled. The equipment and its accessories are made of various types of material, such as metal and plastic. Defective components must be disposed of as special waste. Ask your dealer or your local council.

Disposal



Electronic devices are recyclable waste and must not be disposed of in the household waste. At the end of its service life, dispose of the product according to the relevant statutory regulations.

Remove any rechargeable battery, if necessary, and dispose of it separately from the product.

You thus fulfil your statutory obligations and contribute to environmental protection.

Exceltools.co.uk

Sales@exceltools.co.uk