

EXCEL

1200W Plunge Saw Kit



MODEL:11570

INSTRUCTION MANUAL

Exceltools.co.uk

1. Introduction

Dear Customer,

We hope your new tool brings you much enjoyment and success.

Note:

According to the applicable product liability laws, the manufacturer of the device does not assume liability for damages to the product or damages caused by the product that occurs due to:

- Improper handling,
- Non-compliance of the operating instructions,
- Repairs by third parties, not by authorized service technicians,
- Installation and replacement of non-original spare parts,
- Application other than specified,

A breakdown of the electrical system that occurs due to the non-compliance of the electric regulations and regulations.

We recommend:

Read through the complete text in the operating instructions before installing and commissioning the device. The operating instructions are intended to help the user to become familiar with the machine and take advantage of its application possibilities in accordance with the recommendations. The operating instructions contain important information on how to operate the machine safely, professionally and economically, how to avoid danger, costly repairs, reduce downtimes and how to increase reliability and service life of the machine.

In addition to the safety regulations in the operating instructions, you have to meet the applicable regulations that apply for the operation of the machine in your country. Keep the operating instructions package with the machine at all times and store it in a plastic cover to protect it from dirt and moisture. Read the instruction manual each time before operating the machine and

carefully follow its information. The machine can only be operated by persons who were instructed concerning the operation of the machine and who are informed about the associated dangers. The minimum age requirement must be complied with.

2. Scope of delivery

- Open the packaging and remove the device carefully.
- Remove the packaging material as well as the packaging and transport bracing (if available).
- Check that the delivery is complete.
- Check the device and accessory parts for transport damage.
- If possible, store the packaging until the warranty period has expired.

Attention

The device and packaging materials are not toys! Children must not be allowed to play with plastic bags, film and small parts! There is a risk of swallowing and suffocation!

3. Proper use

The router can be used for rabbeting, rounding off, chamfering, routing of edges, as well as pitting in wood and plastic.

The machine meets the currently valid EU machine directive.

- The manufacturer's safety, operation and maintenance instructions as well as the technical data given in the calibrations and dimensions must be adhered to.
- Relevant accident prevention regulations and other generally recognized safety and technical rules must also be adhered to.
- The machine may only be used, maintained or repaired by trained persons who are familiar with the machine and have been informed about the dangers. Unauthorized modifications of the machine exclude a liability of the manufacturer for damages resulting from the modifications.

- The machine is intended for use only with original spare parts and original tools from the producer.
- The equipment is allowed to be used only for its prescribed purpose. Any other use is deemed to be a case of misuse. The user/operator and not the manufacturer will be liable for any damage or injuries of any kind resulting from such misuse.
- Please note that our equipment has not been designed.
- for use in commercial, trade or industrial applications. Our warranty will be voided if the equipment is used in commercial, trade or industrial businesses or for equivalent purposes.

Residual risks

The machine is allowed to be used only for its intended purpose! Even when the equipment is used as prescribed it is still impossible to eliminate certain residual risk factors. The following hazards may arise in connection with the machine's construction and layout:

- Catapulting of workpieces and parts of workpieces.
- Damage to hearing if essential ear-muffs are not used.
- Lung damage if no suitable protective dust mask is used.
- Health damage caused by hand-arm vibrations if the equipment is used over a prolonged period or is not properly guided and maintained.
- The use of incorrect or damaged mains cables can lead to electrical injuries.
- Although having regarded all considerable rules there may still remain not obvious remaining hazards.
- Minimize remaining hazards by following the instructions in "Safety Rules", "Use only as authorized" and in the entire operating manual.

4. Safety instructions

Caution! In order to protect yourself from the danger of electric shock, injury or fire when using electrical power tools, please observe the following basic safety precautions. Read all these requirements before you use the electrical power tool, and keep the safety advice in a safe place.

Working safely

1. Keep your working area clean and tidy.

- A disorderly working area can lead to accidents.

2. Be aware of the effects of the environment.

- Do not leave electrical power tools out in the rain.
- Do not use electrical power tools in moist or wet surroundings.

- Ensure that your working area is well lit.

- Do not use electrical power tools in areas where there is risk of fire or explosion.

3. Protect yourself from electric shock.

- Avoid touching earthed objects such as pipes, heating radiators, ovens or refrigerators with parts of your body.

4. Keep other people at a safe distance.

- Do not allow other people, in particular children, to touch the electrical power tool or the mains lead. Keep them away from your working area.

5. Store currently unused electrical power tools in a safe place.

- When not being used electrical power tools should be stored in dry conditions in a high or enclosed place, out of reach of children.

6. Do not overload your electrical power tool.

- By keeping within the specified working range of the tool you will work more safely and achieve a better result.

7. Use the right electrical power tool for the task.

- Do not use low-output devices for heavy tasks.
- Do not use an electrical power tool for purposes for which it was not intended.

8. Wear suitable clothing.

- Do not wear loose-fitting clothing or jewellery. They could become caught on moving parts.
- We recommend that you wear anti-slip footwear when working outdoors.
- If you have long hair, wear a hair net.

9. Use personal protective equipment.

- Wear protective glasses.
- Wear a dust mask if your work generates dust.

10. Attaching the vacuum dust extraction device.

- Where there are connection points provided for vacuum dust extraction please ensure that the connections are made and used properly.

11. Do not use the mains lead for purposes for which it was not intended.

- Do not use the mains lead to pull the plug out of the mains socket. Protect the mains lead from heat, oil and sharp edges.

12. Securely support the workpiece.

- Use clamps or a vice to grip the workpiece firmly. This is much safer than holding it with your hand.

13. Avoid placing your body in an unnatural position.

- Keep proper footing and balance at all times.

14. Look after your tools carefully.

- Keep cutting tools sharp and clean. This way you will work more safely and achieve better results.
- Follow the advice on tool lubrication and consumables replacement.
- Check the condition of the mains lead on your electrical power tool regularly and have any damage repaired by a competent specialist.
- Check the condition of extension leads regularly and replace them if they are damaged.
- Keep handles and hand grips clean, dry and free of oil and grease.

15. Pull the mains plug out of the mains socket.

- Do this if the electrical power tool is not being used, before carrying out maintenance tasks on the electrical power tool and whenever you are changing inserted tools, e.g. saw blades, drills or router bits.

16. Make sure that no spanners, keys etc. are left attached.

- Check before switching on that all spanners, keys and setting tools have been removed.

17. Avoid unintentionally starting up the device.

- Check that the switch is set to OFF on the device when the mains plug is inserted into the mains socket.

18. Using an extension lead for working outdoors.

- When working outside, always use an approved and appropriately labelled extension lead.

19. Remain alert.

- Watch what you are doing. Proceed with caution. Do not use electrical power tools if you cannot concentrate.

20. Check the electrical power tool for damage.

- Before the electrical power tool is used, carefully check the safety equipment and any slightly damaged parts to see that they are still working properly.
- Check that all moving parts on the tool are working properly, can move freely and are not damaged. All parts must be correctly attached and fulfil all the requirements necessary to allow the electrical power tool to operate properly.
- Damaged safety equipment and components must be properly repaired or replaced at a competent electrical equipment repair centre unless otherwise indicated in the operating instructions.
- Damaged switches must be replaced at a Customer Service Centre.
- Never use an electrical power tool that cannot be switched on and off properly.

21. Caution!

- The use of inserted tools and accessories other than those recommended by the manufacturer could lead to you being injured.

22. Have your electrical power tool repaired at an electrical equipment repair specialist.

- This electrical power tool complies with the relevant safety regulations. Repairs may only be carried out by a specialist electrical repair centre using original spare parts, otherwise injury could occur to the user.

23. If devices are provided for the connection of dust extraction and collection facilities, ensure these are connected and properly used. Use of dust collection can reduce dust-related hazards.

24. Safety Warnings for Chop and Plunge Saw Kit

a) **Never stand on the power tool.** Serious injuries can occur when the power tool tips over or when inadvertently coming into contact with the saw blade.

b) **Never remove cutting remainders, wood chips, etc. from the sawing area while the machine is running.** Always guide the tool arm back to the neutral position first and then switch the machine off.

c) **Guide the saw blade against the workpiece only when the machine is switched on.** Otherwise there is damage of kickback, when the saw blade becomes wedged in the workpiece.

d) **Keep handles dry, clean, and free from oil and grease.** Greasy, oily handles are slippery causing loss of control.

e) **Operate the power tool only when the work area to the workpiece is clear of any adjusting tools, wood chips, etc.** Small pieces of wood or other objects that come in contact with the rotating saw blade can strike the operator with high speed.

f) **Keep the floor free of wood chips and material remainders.** You could slip or trip.

g) **Use the machine only for cutting the materials listed under Intended use.** Otherwise, the machine can be subject to overload.

h) **If the saw blade should become jammed, switch the machine off and hold the workpiece until the saw blade comes to a complete stop. To prevent kickback, the workpiece may not be moved until after the machine has come to a complete stop.** Correct the cause for the jamming of the saw blade before restarting the machine.

i) **Do not use dull, cracked, bent or damaged saw blades.** Unsharpened or improperly set saw blades produce narrow kerf causing excessive friction, blade binding and kickback.

j) **Always use saw blades with correct size and shape (diamond versus round) of bore.** Saw blades that do not match the mounting hardware of the saw will run eccentrically, causing loss of control.

k) **Do not touch the saw blade after working before it has cooled.** The saw blade becomes very hot while working.

l) **Check the cable regularly and have a damaged cable repaired only through an authorised customer service agent. Replace damaged extension cables.** This will ensure that the safety of the power tool is maintained.

m) **Store the machine in a safe manner when not being used. The storage location must be dry and lockable.** This prevents the machine from storage damage, and from being operated by untrained persons.

n) **Secure the workpiece.** A workpiece clamped with clamping devices or in a vice is held more secure than by hand.

o) **Never leave the machine before it has come to a complete stop.** Cutting tools that are still running can cause injuries.

p) **Never use the machine with a damaged cable. Do not touch the damaged cable and pull the mains plug when the cable is damaged while working.**

Damaged cables increase the risk of an electric shock.

q) Maintain power tools. Check for misalignment or binding of moving parts, breakage of parts and any other condition that may affect the power tool's operation. If damaged, have the power tool repaired before use. Many accidents are caused by poorly maintained power tools.

r) Use the power tool, accessories and tool bits etc. in accordance with these instructions, taking into account the working conditions and the work to be performed. Use of the power tool for operations different from those intended could result in a hazardous situation.

5. Technical Data

Specifications:

Voltage :	240V / 50Hz
Power :	1200W
No load Speed :	5200rpm
Blade Spec :	Ø165x20mmx24T
Mitre Angle :	0°-45°
Guide Rail :	2x700mm
Cutting Capacity:	55mm@90° 42mm@45°

Package Contents:

Plunge Saw
Blade
2 x 700mm Guide Rails
Guide Rail Joiner
2 x Guide Rail Clamps
2 x Hex key
Instruction Manual

Intended Use

This power tool is intended to remove and collect wood shavings only. Any other use is considered as not intended use and any damages or injuries result from this unintended use is at operators own risk.

The capacity of the power tool is designed for sawing hardwood and softwood.

The power tool is not suitable for cutting aluminium or other non-ferrous metals or alloys.

This item is also not intended to be used for continuous production or production line use.

6. Product Features

1. Cable and plug
2. Dust Port
3. Safety Switch
4. ON/OFF Trigger
5. Blade Change Lever
6. Front Handle
7. Rear Bevel Locking Knob
8. Saw Blade
9. Front Bevel Locking Knob
10. Cutting Line Guide
11. Cutting Depth Scale
12. Bevel Angle Scale
13. Cutting Depth Knob
14. Base Plate
15. Blade Locking Lever
16. Guide Rail Adjusting Knob
17. Rear Handle

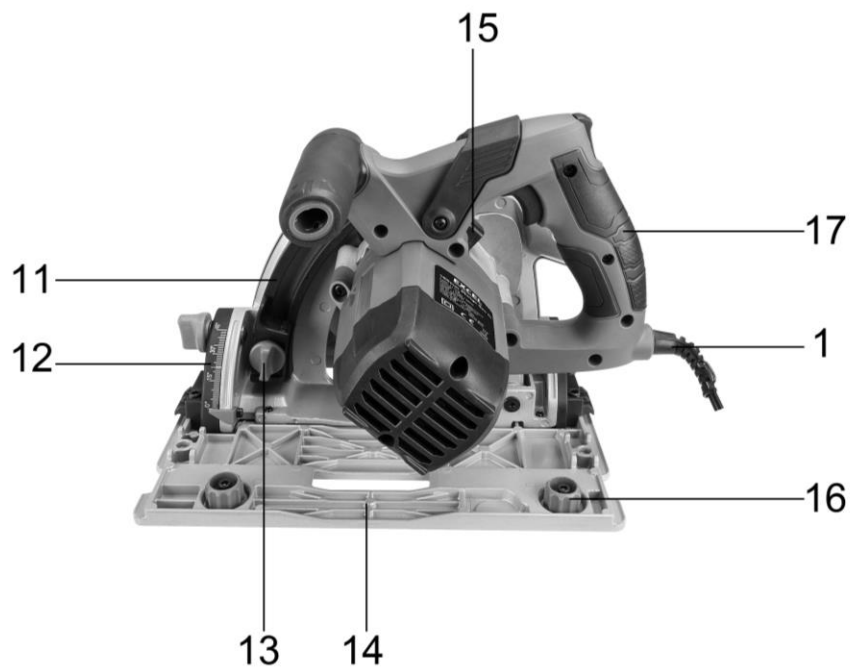
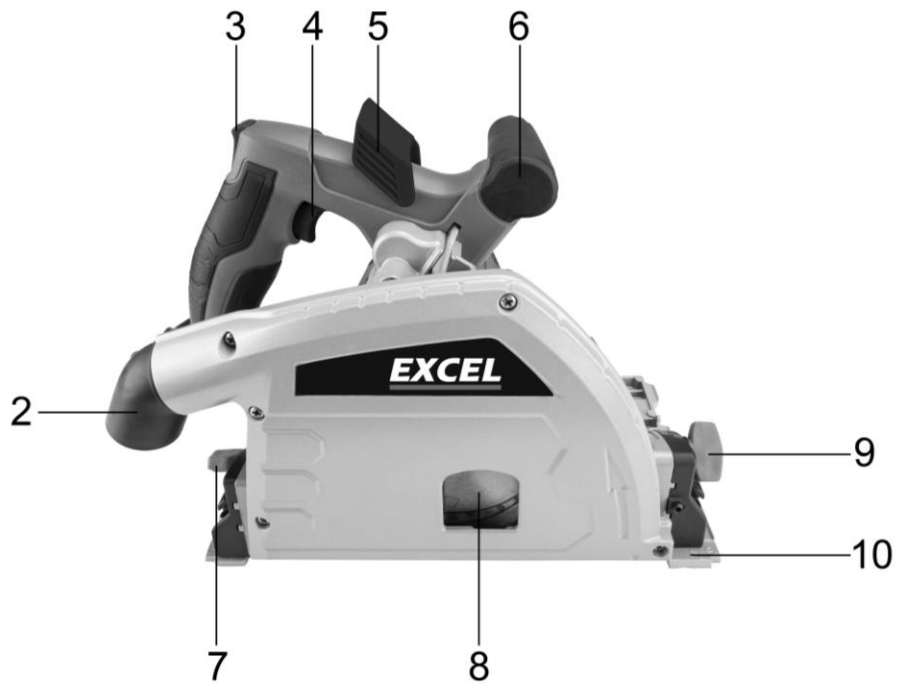

7. Assembly

Avoid unintentional starting of the machine. During assembly and for all work on the machine, the power plug must not be connected to the mains supply.

Carefully remove all parts included in the delivery from their packaging.

Remove all packaging material from the machine and the accessories provided.

Before starting the operation of the machine for the first time, check if all parts listed in the box content section have been supplied

Note: Check the power tool for possible damage. Before further use of the machine, check that all protective devices are fully functional. Any lightly damaged parts must be carefully checked to ensure flawless operation of the tool. All parts must be properly mounted and all conditions fulfilled that ensure faultless operation.

Damaged protective devices and parts must be immediately replaced by an authorised service centre.

Depth & Bevel Adjustment

Depth should be adjusted so that no more than one tooth is protruding through the timber.

This helps to minimise splintering.

1. Loosen the Cutting Depth Knob.

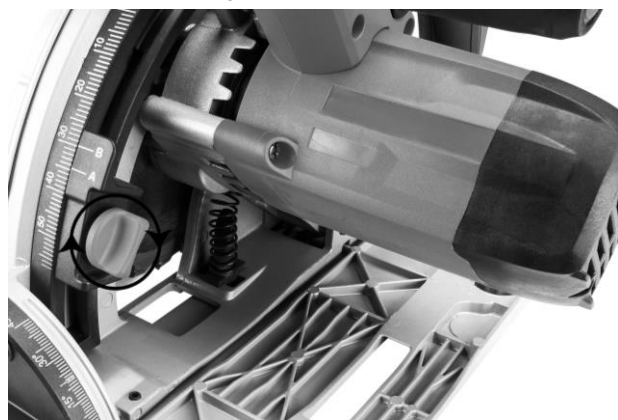

2. Press the Knob inwards and slide to set the desired depth using the Cutting Depth Scale.

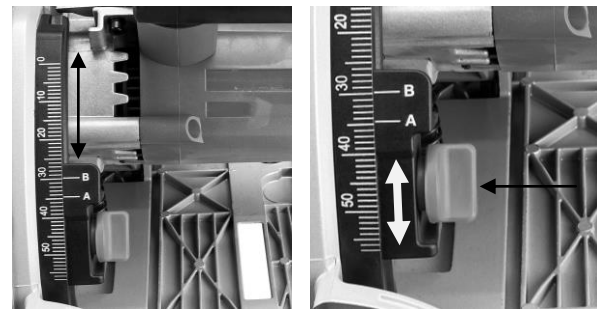

● Cutting depth **A** shows the cutting depth **WITHOUT** Guide rail fitted.

● Cutting depth **B** shows the cutting depth **WITH** Guide rail fitted.

3. Tighten Cutting Depth Knob.

Bevel Adjustment

1. Loosen both Bevel Locking Knobs.



2. Align Base Plate to desired angle on Bevel Angle Scale (A).

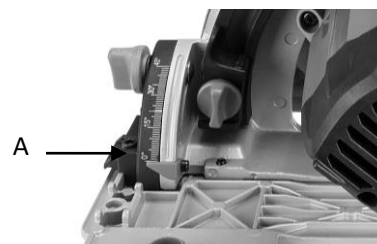

3. Tighten Bevel Locking Knobs.



8. Operation

Warning!: The tool is recommended for use with a residual current device with a rated residual current of 30mA or less.

Turning ON and OFF

1. Slide and hold the Safety Switch then squeeze the ON/OFF Trigger to start the saw.



NOTE: Allow the saw to reach full speed before beginning a cut.

2. To stop the saw, release the ON/OFF Trigger (B).

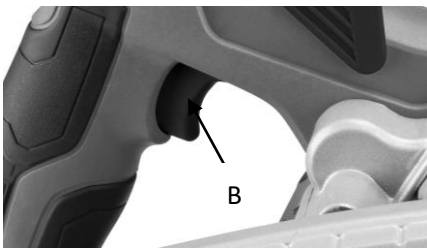

WARNING!: After use, hold the saw away from your body until the blade stops completely.

Guide Rail Adjustment

Tighten or loosen the Adjusting knobs to minimise or increase the clearance between the plunge saw and the guide rail.



Cutting Line Guides

The Cutting guide will give an approximate line of cut. For a straight cut, use the 0° notch. For a 45° cut, use the 45° notch.

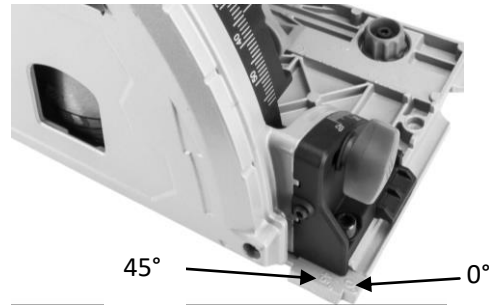

Using the Guide Rail

1. To connect two rails, slide the joiner into the notch on the underside of one Guide Rail then tighten the screws with the small (3mm) Hex Key provided.

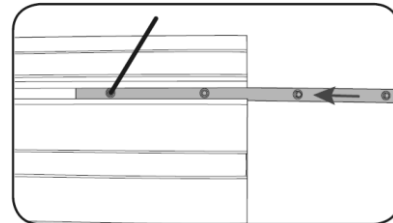

2. Slide on the second Guide Rail fully into position and tighten in place.

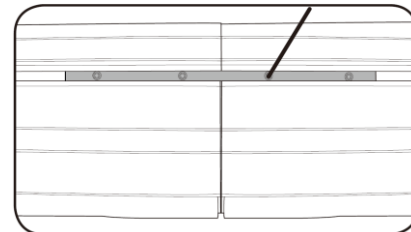

Note: Additional Guide Rails may be assembled if required by following the above steps.

3. Place the Plunge Saw in the Guide Rail.

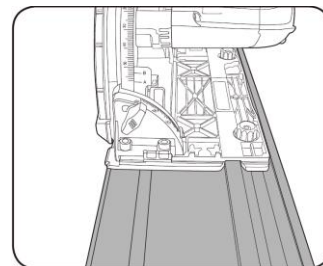

Note: In confined spaces using one 700mm guide rail is ideal

Sawing With the Guide Rail

The Guide Rail is used to carry out straight cuts. The rubber lip (black rubber lip) on the guide rail acts as a splinter guard; it prevents fraying of the surface while sawing wooden materials. For this, the teeth of the saw blade must face directly against the rubber lip.

Note: On the very first cut, the rubber lip will be adapted with the guide rail to the plunge saw.

1. Place the Guide Rail onto the material to be cut.

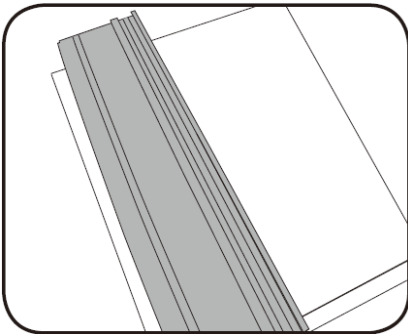

2. Place a Clamp at either end of the Guide Rail and clamp the material to be cut.

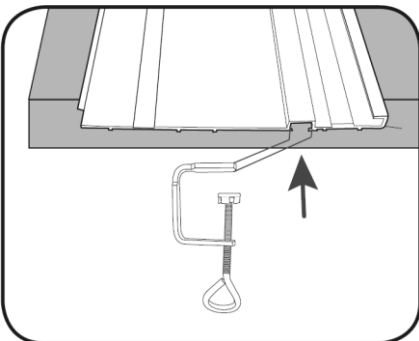

3. Ensure the cutting depth is set and locked to the desired depth.

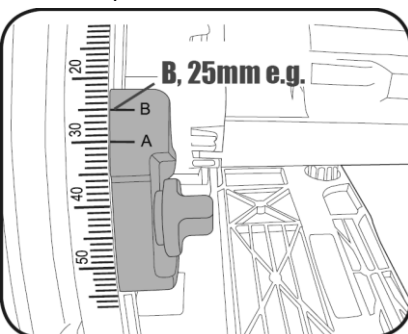

4. Place the Plunge Saw in the guide Rail.

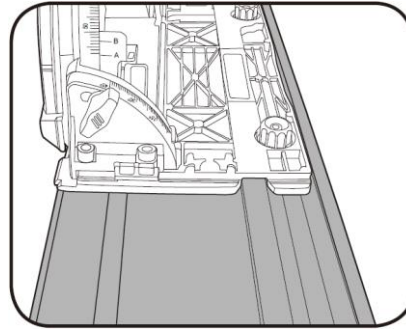

5. Hold the saw securely with both hands and start the tool.

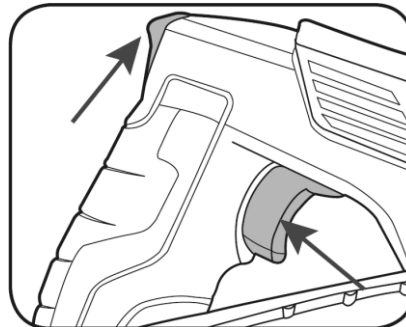

6. Press the saw downwards to reach the sawing depth set at step 3.

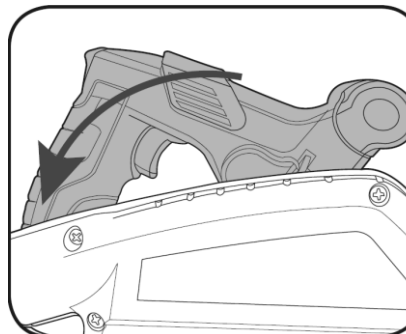

7. Move the saw through the material to perform the cut.

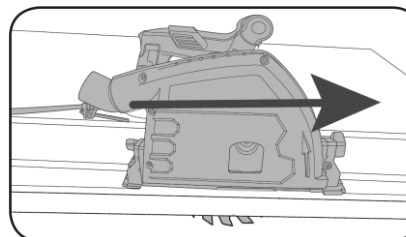

8. Once complete, release the ON/OFF trigger and move the saw blade upwards.

9. Blade fitment

Warning! Ensure the tool is switched OFF and disconnected from the power supply before performing any of the following tasks.

The tool is recommended for wood cutting only and is not recommended for use with abrasive wheels or masonry/diamond cutting wheels. Only use 165mm wood cutting blades.

1. Lift the Blade Change Lever.

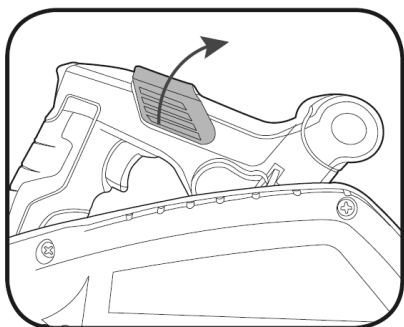

2. Press and hold the Safety Switch and push the saw downwards until the Blade Bolt is visible. The motor will lock into place.

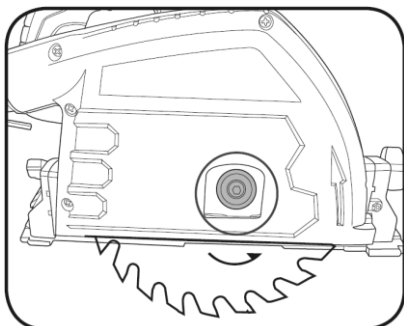

3. Press and hold the Blade Locking Lever.

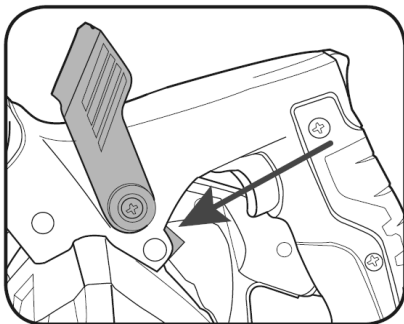

4. Use the large (5mm) Hex Key to undo the Blade Bolt, turning anti-clockwise.

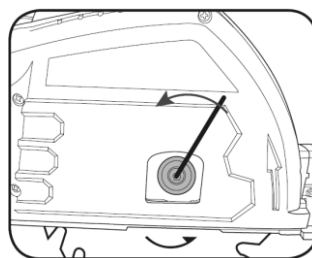

Important! Always wear gloves when handling saw blades, risk of injury.

5. Remove and replace blade. Ensure arrows on the blade point in the same direction as the arrow on the blade guard.

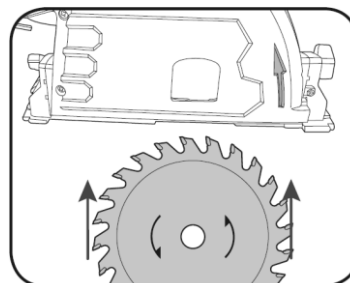

6. Fit outer Blade Flange and blade bolt. Depress blade Locking Lever and tighten blade bolt.

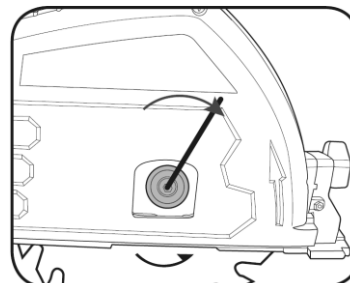

7. Set the plunge saw to its original position.

10. Maintenance

Keep your tool in good repair by adopting a regular maintenance program. Before use, examine the general condition of your tool. Inspect guards, switches, tool cord set and extension cord for damage. Check for loose screws, misalignment, binding of moving parts, improper mounting, broken parts and any other condition that may affect its safe operation. If abnormal noise or vibration occurs, turn the tool off immediately and have the problem corrected before further use. Do not use a damaged tool. Tag damaged tools "DO NOT USE" until repaired (see "Repairs").

Under normal conditions, relubrication is not necessary until the motor brushes need to be replaced.

After six months to one year, depending on use, return your tool to the nearest service station facility for the following:

- Lubrication
- Brush inspection and replacement
- Mechanical inspection and cleaning (gears, spindles, bearings, housing, etc.)
- Electrical inspection (switch, cord, armature, etc.)
- Testing to assure proper mechanical and electrical operation
- Keep the vents of the saw clean at all times.

If possible, prevent foreign matter from entering the vents.

- After each use, blow air through the saw housing and guard, to ensure it is free from all dust particles which may build up. Build up of dust particles may cause the saw to overheat and fail.
- If the enclosure of the saw requires cleaning, do not use solvents but a moist soft cloth only. Never let any liquid get inside the saw; never immerse any part of the saw into a liquid.
- The grease in the gearbox will require replenishment after extensive use of the saw. Please see a power tool repairer to provide this service.

Carbon Brushes

When the carbon brushes wear out, the saw will spark and/or stop. Discontinue use as soon as this happens.

They should be replaced prior recommencing use of the saw. Carbon brushes are a wearing component of the saw therefore not covered under warranty.

Continuing to use the saw when carbon brushes need to be replaced may cause permanent damage to the saw. Carbon brushes will wear out after many uses.

When the carbon brushes need to be replaced, take the saw to an electrician or a power tool repairer for a quick and low cost replacement. Always replace both carbon brushes at the same time.

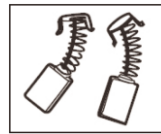

Cleaning

Clean dust and debris from vents. Keep the tool handles clean, dry and free of oil or grease. Use only mild soap and a damp cloth to clean your tool since certain cleaning agents and solvents are harmful to plastics and other insulated parts. Some of these include: gasoline, turpentine, lacquer thinner, paint thinner, chlorinated cleaning solvents, ammonia and household detergents containing ammonia. Never use flammable or combustible solvents around tools.

11. Troubleshooting

Circular saw tips

Always hold the soft grip handle with one hand and the front handle with the other. Maintain a firm grip and operate the ON/OFF switch with a positive action.

Never force the saw. Use light and continuous pressure. Allow the saw to reach full speed before beginning a cut.

When cutting is interrupted, to resume cutting, depress the lock-off button and squeeze the ON/OFF switch and allow the blade to reach full speed, re-enter the cut slowly and resume cutting.

When cutting across the grain, the fibres of the wood have a tendency to tear and lift. Advancing the saw slowly minimizes this effect. For a finished cut, a cross cut blade or mitre blade is recommended.

Sparking visible through the housing air vents

A small amount of sparking may be visible through the housing vents. This is normal and does not indicate a problem.

Excessive sparking visible through the housing air vents and/or the saw failing to operate

May indicate the carbon brushes have worn out and need to be replaced. Carbon brushes should only be replaced by a qualified electrician or power tool repairer.

Parts Diagram and Parts List

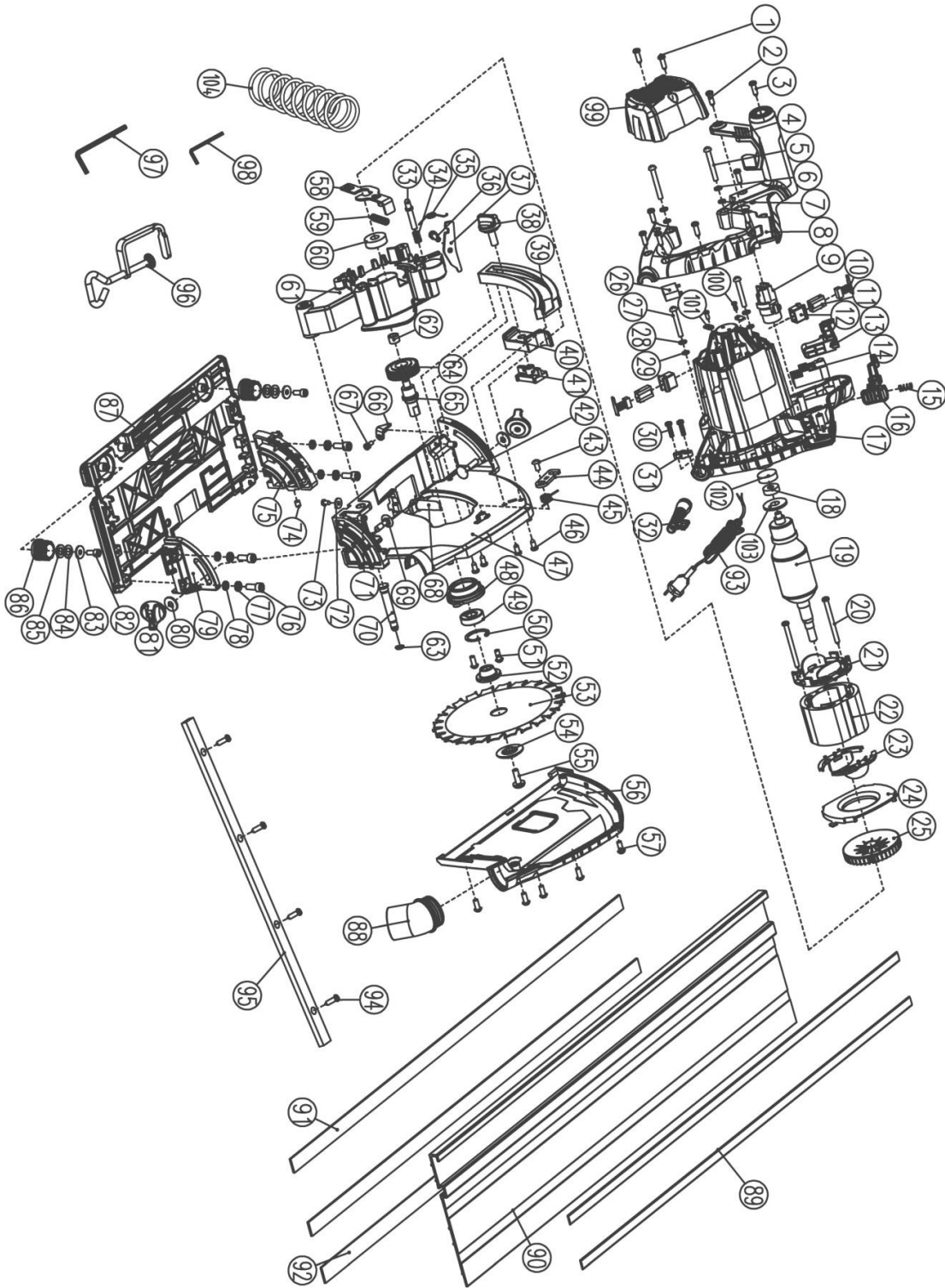

Exceltools.co.uk

Parts Diagram and Parts List

No.	Description	No.	Description
1	Self tapping screw ST4.1x16-F	36	Hexagon socket cap screws M5x16
2	Self tapping screw ST4.1x16-F	37	Lifting limit shaft
3	Self tapping screw ST4.1x16-F	38	Locking knob
4	Lock handle	39	Depth mark
5	Pan head screw M5x42	40	Lifting instructions block
6	Small washer	41	Lifting instructions block sea
7	Spring washer	42	Square neck bolt M6x30
8	Handle	43	Flat head screw M5x12
9	Lock wheel	44	Locking plate
10	Carbon brush assembly	45	Torsion Spring for locking plate
11	Copper bush	46	Self tapping screw ST4.1x12-F
12	Brush box	47	Fixed guard
13	Switch trigger	48	Gear cover
14	Switch	49	Bearing 6001-2RS (40x17x12)
15	Switch spring	50	Circlip for hole 28
16	Push rod	51	Lock screw M5X12
17	Housing	52	Saw blade seat
18	Bearing 607RS	53	Saw blade
19	Armature assembly	54	Saw blade cover plate
20	Self tapping screw ST4.1x65-F	55	Flat round head screw M8x20
21	Stator insulation board(front)	56	Upper cover
22	Stator assembly	57	Lock screw M4x12
23	Stator insulation board(back)	58	Spanner for spindle lock
24	Fan shroud	59	Spring for spindle lock
25	Fan	60	Bearing 6000RS
26	Capacitor 0.33μ	61	Gear box
27	Pan head screw M5x35	62	Oil bearing
28	Self tapping screw ST4.1x16-F	63	Circlip for shaft
29	Self tapping screw ST4.1x16-F	64	Big gear
30	Self tapping screw ST4.1x16-F	65	Output shaft
31	Cable clamp	66	Dial pointer
32	Cable sheath	67	Hexagon socket cap screws M4x6
33	Lifting locking pin	68	Lift spring seat
34	Spring	69	Square neck bolt M6x2
35	Torsion Spring	70	Spindle

Parts Diagram and Parts List

No.	Description	No.	Description
71	Lock screw M6x2	88	Dust pipe
72	Big washer	89	Rail friction strip
73	Self tapping screw ST3.5x9-F	90	Rail
74	Lock screw M6x8	91	Rail antislip strip
75	Front bracket	92	Rail rubber strip
76	Hexagon socket cap screw M6x15	93	Cable and plug
77	Small washer	94	Lock screw M6X6
78	Spring washer	95	Rail connect strip
79	Back bracket	96	Clamping device
80	Big washer	97	Socket head wrench 5mm
81	Adjust knob	98	Socket head wrench 3mm
82	Hexagon socket cap screw M5x12	99	Motor cover
83	Big washer	100	Screw
84	Wave washer	101	Holder plate
85	Small washer	102	Ball bearing vibration damper
86	Adjust knob	103	Insulation
87	Base plate	104	Spring

