



MB02

Lightweight Stroller

GB Instruction Manual

ES Manual de instrucciones



IMPORTANT, RETAIN FOR FUTURE REFERENCE: READ CAREFULLY

Welcome to the familiee

Your trust in our product means the world to us, and we're thrilled to be a part of your parenting journey. Our team has worked tirelessly to ensure that the MB02 provides comfort, safety, and style for you and your little one. We're confident it will exceed your expectations. Should you have any questions or require assistance in the future, please don't hesitate to reach out. Thank you for choosing My Babiie; we wish you and your family countless wonderful strolls ahead.

Get to know your MB02 Stroller

Scan the QR code below on your camera app to be linked off to our page to get all the information you need for using your MB02 Stroller. From setting it up to how to fold it down, it's all there!



SCAN ME



Warranty

We provide a 1 year warranty against manufacturing or material defects.

The warranty period is effective from the day of purchase and applicable to the UK and Ireland. If you made your purchase from an authorised retailer, please return your product to them.

If you bought your product via our website; mybabiie.com, please contact our Customer Service team via email (info@mybabiie.com). We are happy to refund any product if you change your mind about your purchase (if purchased from our website, mybabiie.com.) As long as you tell us within 30 days of receiving your goods. They must be returned in an unused condition, in the original, undamaged packaging and complete with all original parts and accessories. Proof of purchase is required.

What is not covered by the Guarantee?

- Failure to follow My Babiie user guide and maintenance instructions.
- Damage caused by non domestic use
- General wear and tear, for example: worn wheels, damaged rain covers, worn/tear fabric.
- Deliberate damage, misuse or neglect.
- Product which has been modified, undergone an unauthorised repair or used a non approved spare part.
- Car seats which have been involved in an accident, we recommend all car seats should be replaced if involved in an accident.
- Cosmetic damage.
- Parts subject to normal wear and tear, foam handles, rubber elements of wheels, signs of fabric wear.
- Loss incurred as a result of not being able to use a product whilst waiting for a spare part or repair.

A repair service is available for any item that sustains accidental damage at any point during its lifespan. If the damages are not covered by our guarantee, we will provide a quote for the repair costs on an individual basis. If you find yourself in need of spare parts that are not covered by the warranty, you can purchase each spare part on our website (subject to availability).

To read more about your guarantee, please visit mybabiie.com/guarantee.

Our guarantee is provided by My Babiie Ltd, Registered address: 15 Commercial Road, Paddock Wood, Kent, TN12 6EN .

Your statutory rights are not affected by the guarantee.

Registering your Warranty

To register your warranty please visit www.mybabiie.com/warranties

Registering for your product warranty allows you to claim repairs or replacements if your product develops a fault. It will also help us contact you in the event of a product issue that you may need to be made aware of.

Problems or Questions

If you have any questions about your product then please drop us an email at info@mybabiie.com and we will get back to to you as soon as possible. Alternatively, you can chat to us on our Live Support Chat on our website mybabiie.com or contact us via our social media channels.

What's in the box

1

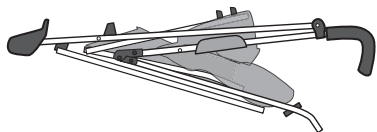

2

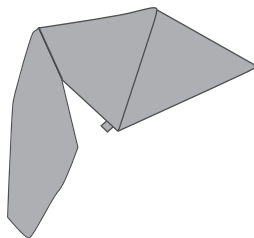

3



4

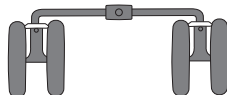

5



6



7



1. Frame

2. Canopy

3. Front swivel wheels

4. Rear wheels

5. Bumper bar

6. Cup holder

7. Raincover

Pushchair assembly

- 1** Undo the plastic catch located on the side of the pushchair to release the frame.

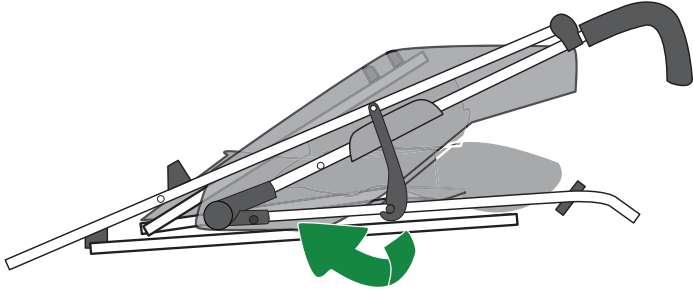

- 2** Using your foot, push down on the lever at the back of the pushchair (a) and at the same time pull up the stroller handles to open up the stroller frame (b).

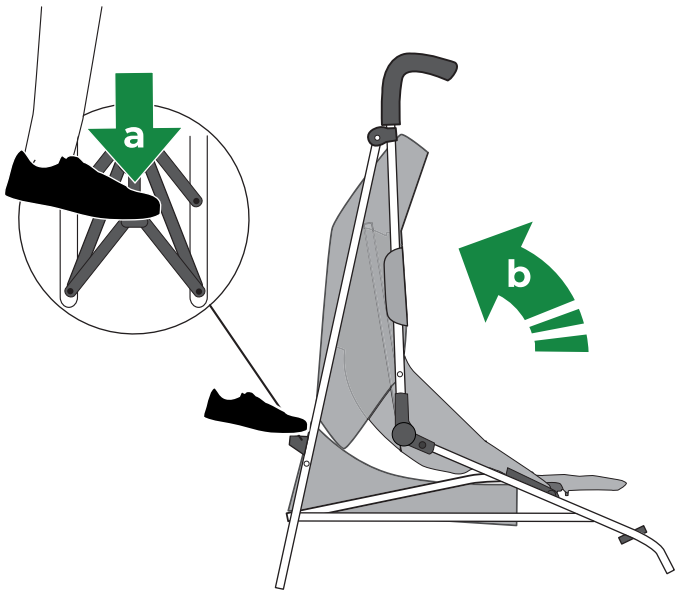

- 3** Attach the rear wheel set by pushing it onto the rear legs. You will hear a click sound once successfully attached.

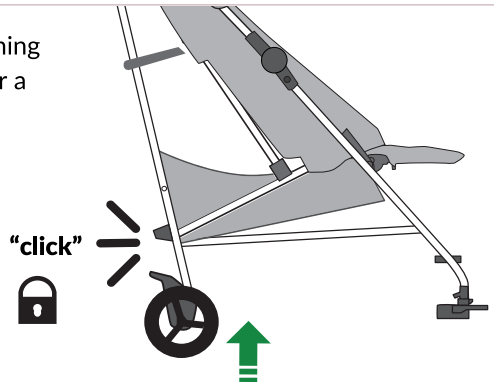

- 4** Push both front wheels onto the ends of the frame's front legs. You will hear a click sound once successfully installed.

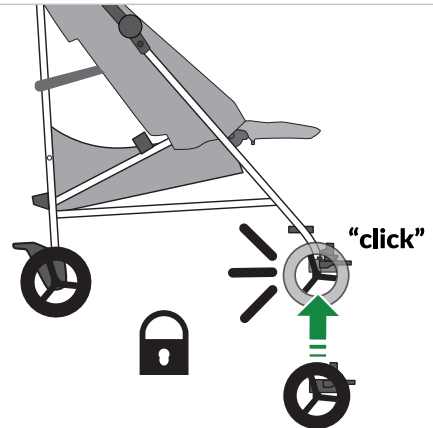

- 5** The front wheels can be fixed into position or they can be set to swivel 360°. Pull the small lever up to lock them in position or push it down to allow them to swivel a full 360°.

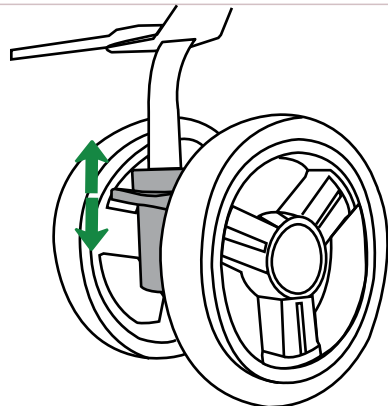

6 Using the brakes

Press the brake pedal on the back of either wheel to apply the brakes. To release them, lift the pedal with your toes. Always apply the brake when placing the child in or out of the pushchair.

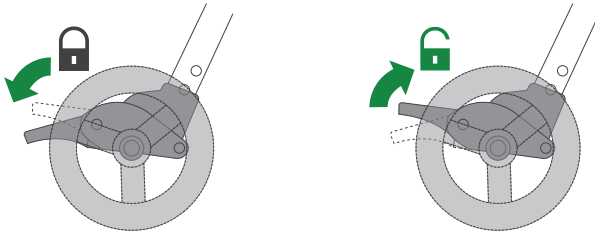

7 Canopy

Align the canopy over the pushchair and slide the plastic parts on each side of the canopy down onto the plastic clips on each side of the stroller frame.

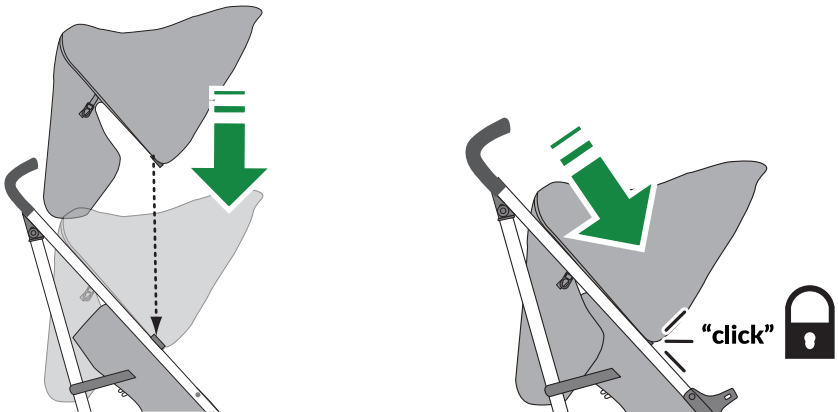

8 The canopy has three positions. Pull the canopy forward to completely unfold it and push it back to retract it.

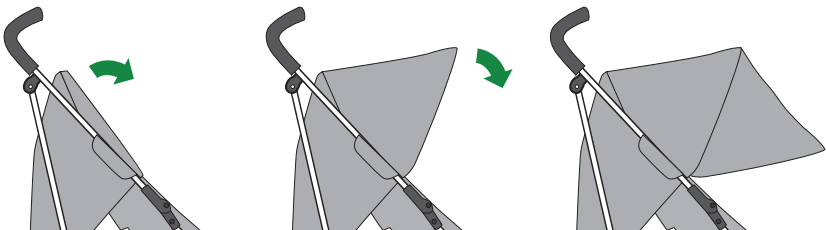

9 Bumper bar

Fix the bumper bar to the front of the pushchair by lining it up each side and pushing into place. You will hear a click sound once successfully installed. To remove it, press the buttons each side of the bumper bar and pull to remove.

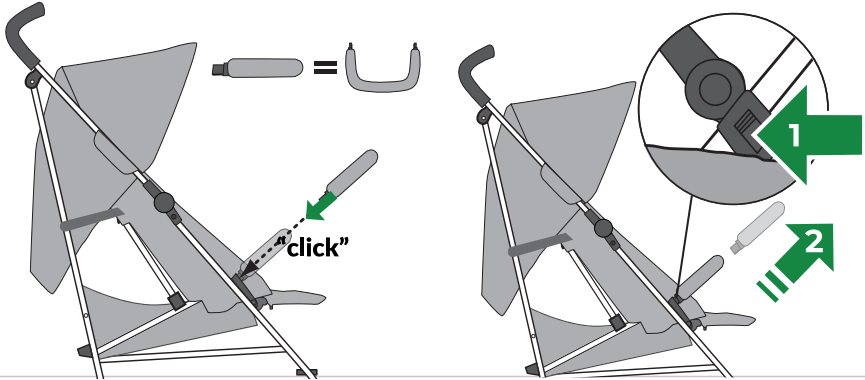

10 Seat recline

Press the lever on the back of the seat unit to lower the position of the seat (a). Simply push the seat back up to raise the recline position (b).

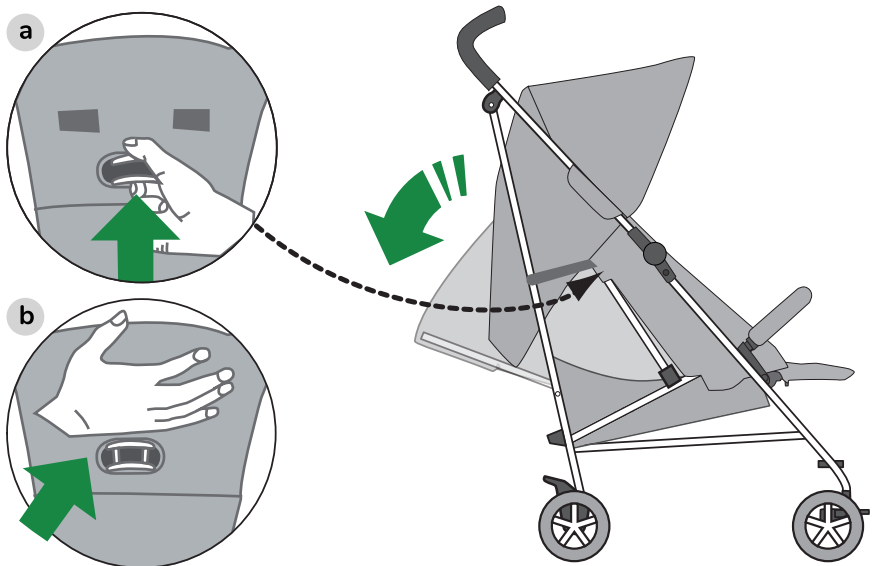

- 11** The fully reclined position is ideal for newborn babies (0+).

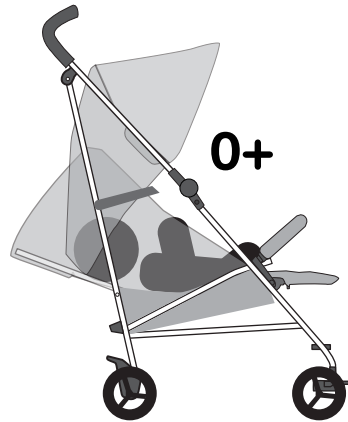

12 Footrest

The footrest is foldable, press the buttons located on the back (each side), to unlock then move it to a comfortable setting.

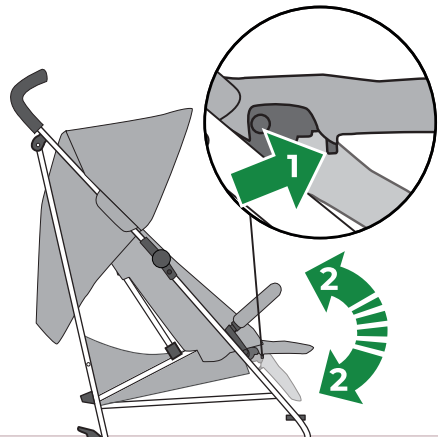

13 Harness

Attach the side belts to both vertical straps, and push these to the centre buckle until you hear a CLICK. The safety harness can be adjusted to fit the comfort of your child.

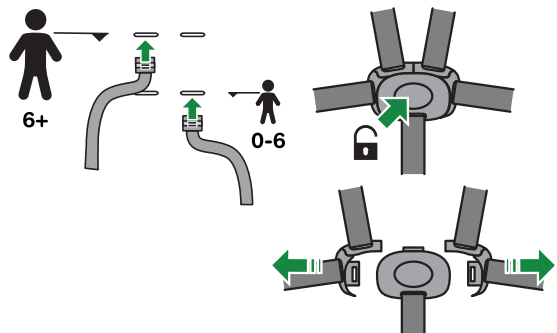

To release the seat belt, press the center button.

- 14** For children under 6 months you can thread the chest harnesses through the fabric tabs on the seat.

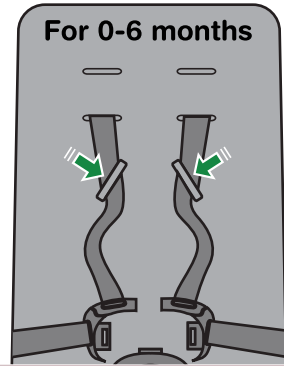

15 Folding the pushchair

- (a) Fold the canopy completely back.
- (b) Lift the lever at the back of the pushchair with your foot (1) then push down on the side lever (2).
- (c) Push the stroller forward from the handles.
- (d) Once fully folded use the latch on the side of the pushchair to hold it shut.

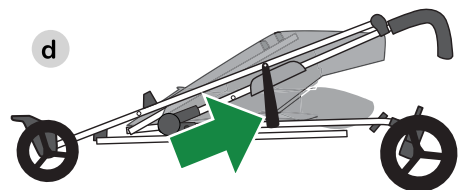
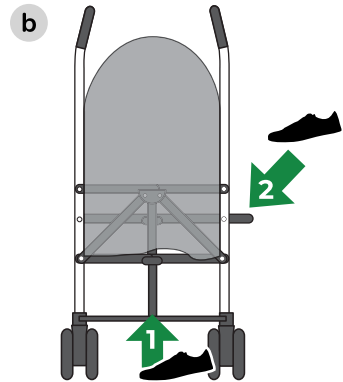
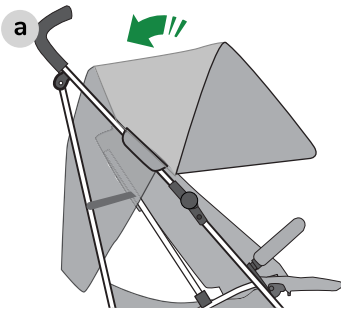

Pushchair warnings

IMPORTANT, RETAIN FOR FUTURE REFERENCE: READ CAREFULLY

Please read these instructions carefully before use and keep them for later reference.

Remove all packaging and non-permanent labels and dispose of safely before using this product. The safety of your child could be put at risk if you do not follow these instructions.

This stroller is designed for 1 child from 0 months up to a weight of 22 kg/36 months.

WARNING: Never leave your child unattended.

WARNING: Uneven or excessive loading of items on or in the stroller may cause the product to tip and may cause injury.

WARNING: Maximum intended weight within the shopping basket is 3kg.

WARNING: Ensure that all the locking devices are engaged before use.

WARNING: To avoid injury ensure that your child is kept away when unfolding and folding this stroller.

WARNING: Do not let your child play with this stroller.

WARNING: Always use the restraint system.

WARNING: Check that the pram body or seat attachment devices are correctly engaged before use.

WARNING: Do not put hot drinks or liquids in the cup holder.

WARNING: This product is not suitable for running or skating.

WARNING: Do not insert any additional mattresses into the stroller.

WARNING: Accessories which are not approved by the manufacturer shall not be used.

WARNING: This pushchair has been designed for one child and shall be used for the transport for only one child!

WARNING: Always use the crotch strap in combination with the waist belt.

WARNING: This stroller does not replace a cot or a bed. Should your child need to sleep, then it should be placed in a suitable cot or bed.

WARNING: Only replacement parts supplied or recommended by My Babiie shall be used.

WARNING: Any load attached to the handle and on the back of the backrest and on the sides of the stroller will affect the stability of the stroller.

WARNING: The parking device shall be engaged when placing and removing the children.

EN 1888-1:2018+A1:2022 and EN 1888-2:2018+A1:2022 approved

Care and maintenance

- Please check on a regular basis that the brakes, wheels, latches, connecting elements, belt systems and seams are properly functional.
- Do not expose the stroller to strong sunshine.
- Sponge clean only.
- After use in rain or snow, the wheels should be lubricated and the stroller dried to prevent rust.
- Care for, clean and check this stroller regularly.
- Do not use accessories that have not been approved by the manufacturer.

Your child's safety is your responsibility

If you have a problem with this product or require replacement parts, please visit www.mybabiie.com/support

Register your product at: www.mybabiie.com/warranties

Partes incluidas

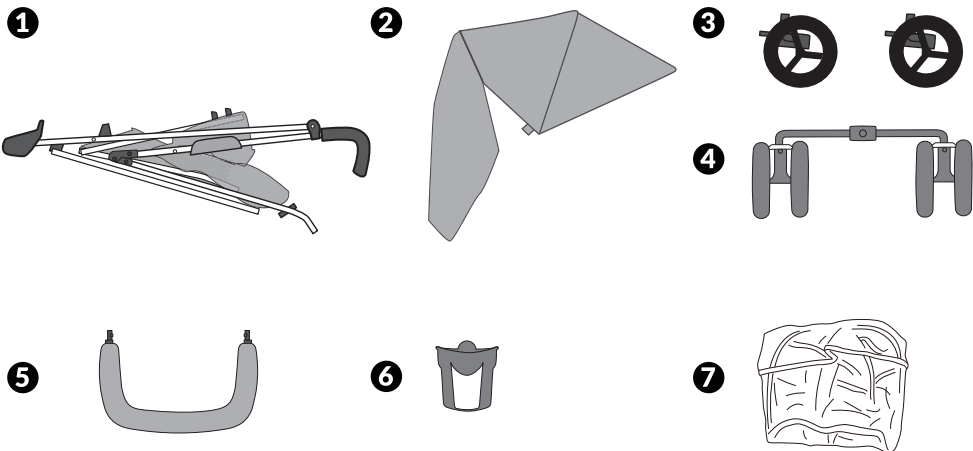

1. Marco

2. dosel

3. Ruedas delanteras giratorias

4. Ruedas traseras

5. Barra parachoques

6. Portavasos

7. Protector de lluvia

- 1 Desenganche el cierre de plástico situado en el lateral del cochecito para liberar el armazón.

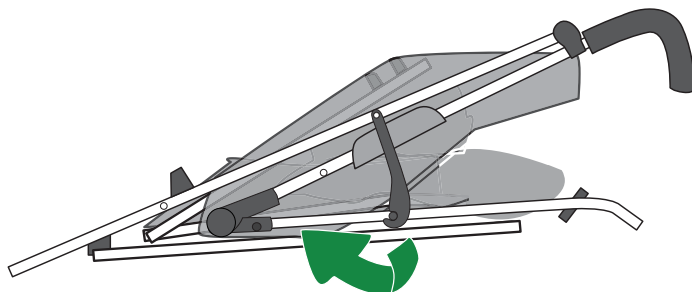

- 2 Con el pie, empuje hacia abajo la palanca en la parte trasera del cochecito (a) y al mismo tiempo levante las manijas del cochecito para abrir el armazón del cochecito (b).

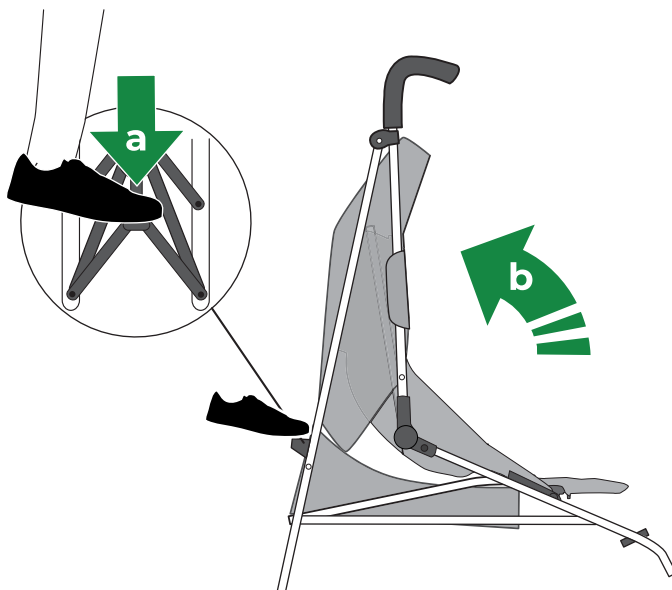

- 3** Coloque el juego de ruedas traseras empujándolo sobre las patas traseras. Escuchará un sonido de clic una vez que se haya conectado correctamente.

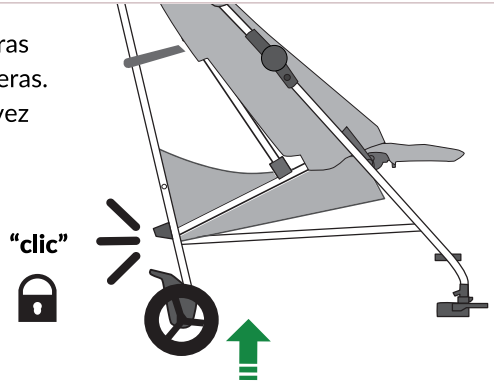

- 4** Empuje ambas ruedas delanteras hacia el extremos de las patas delanteras del marco. Escuchará un sonido de clic una vez que se haya instalado correctamente.

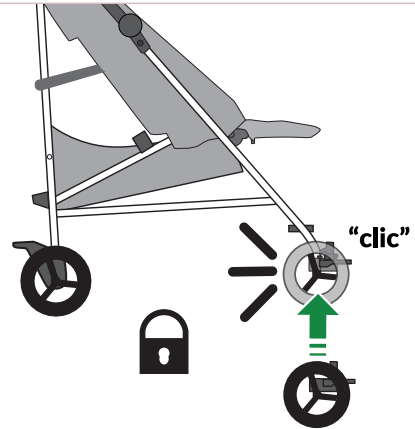

- 5** Las ruedas delanteras se pueden fijar en su posición o se pueden ajustar para que giren 360°. Tire de la pequeña palanca hacia arriba para bloquearlos en su posición o empujela hacia abajo para permitir que giren 360° completos.

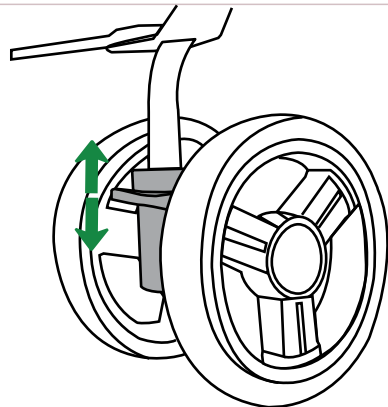

6 Usando los frenos

Presione el pedal del freno en la parte trasera de cualquiera de las ruedas para aplicar los frenos. Para soltarlos, levante el pedal con los dedos de los pies. Aplique siempre el freno al colocar o sacar al niño del cochecito.

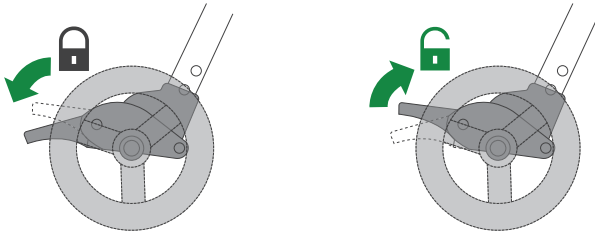

7 Pabellón

Alinee la capota sobre el cochecito y deslice las piezas de plástico a cada lado de la capota hacia abajo sobre los clips de plástico a cada lado del armazón del cochecito.

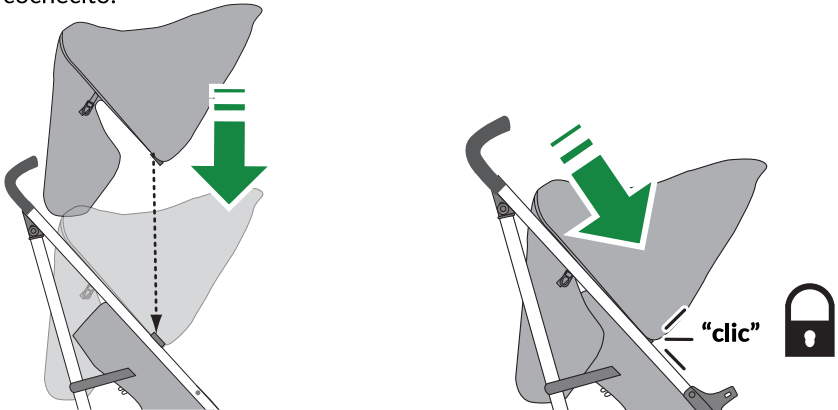

8 El dosel tiene tres posiciones. Tire de la capota hacia adelante para desplegarla completamente y empújela hacia atrás para retraerla.

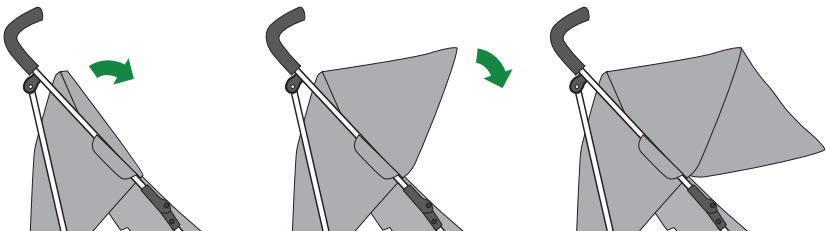

9 barra de parachoques

Fije la barra protectora a la parte delantera del cochecito alineándola a cada lado y empujándola en su lugar. Escuchará un sonido de clic una vez que se haya instalado correctamente.

Para quitarlo, presione los botones a cada lado de la barra del parachoques y tire para quitarlo.

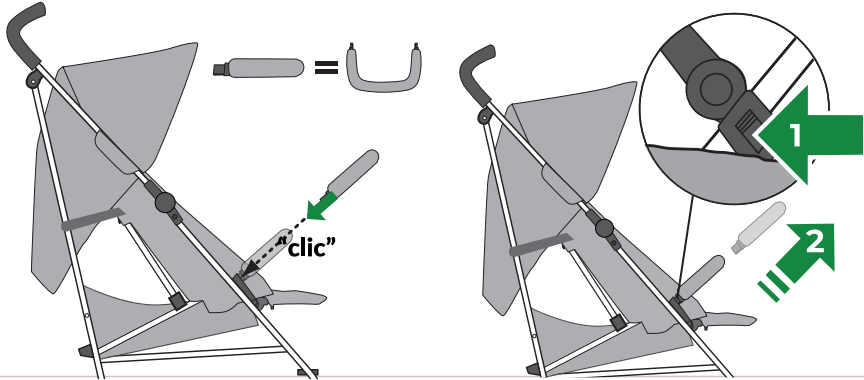

10 inclinación del asiento

Presione la palanca en la parte posterior de la unidad del asiento para bajar la posición del asiento (a). Simplemente empuje el respaldo hacia arriba para elevar la posición reclinada (b).

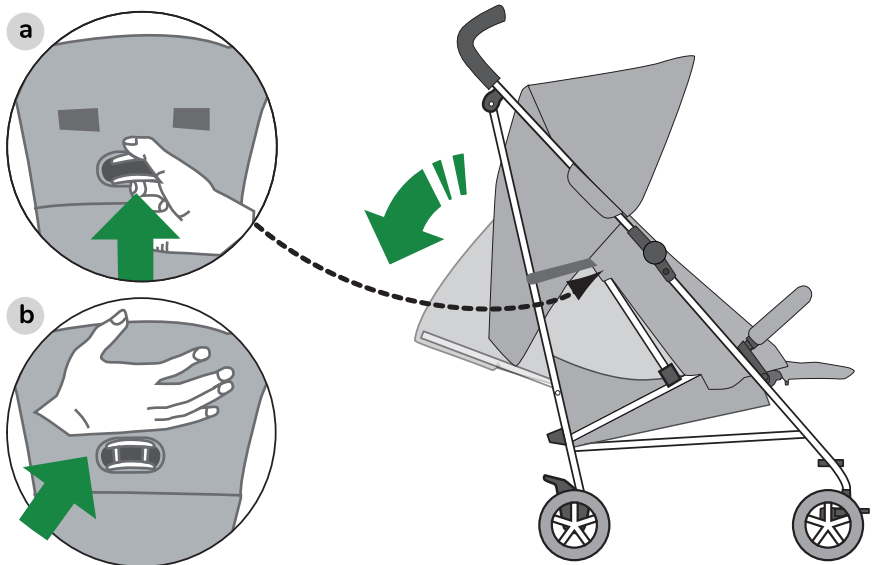

- 11** La posición completamente reclinada
Es ideal para bebés recién nacidos (0+).

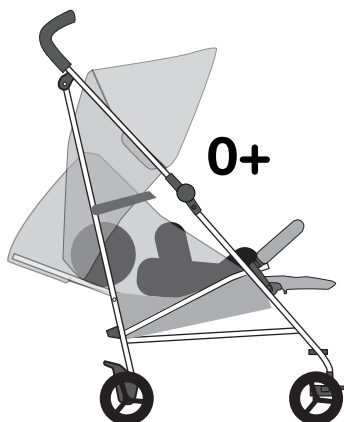

- 12 Reposapiés**
El reposapiés es plegable, presione los botones ubicados en la parte posterior (a cada lado) para desbloquearlo y luego muévelo a una posición cómoda.

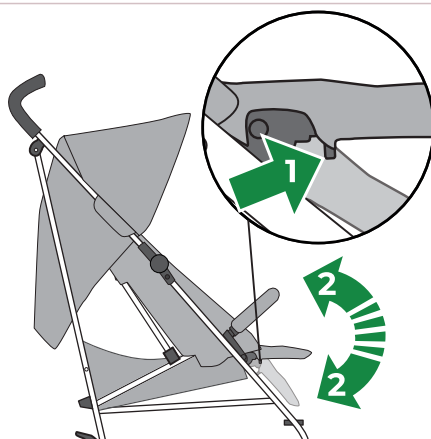

- 13 Aprovechar**
Conecte los cinturones laterales a ambas correas verticales y empújelos hacia la hebilla central hasta que escuche un CLIC. El arnés de seguridad se puede ajustar para adaptarse a la comodidad de su hijo. Para soltar el cinturón de seguridad, presione el botón central.

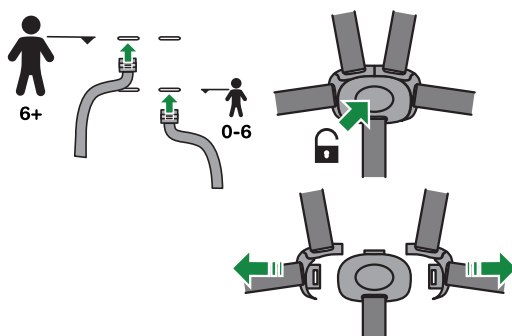

- 14** Para niños menores de 6 meses, puede pasar los arneses de pecho a través de las pestañas de tela del asiento.

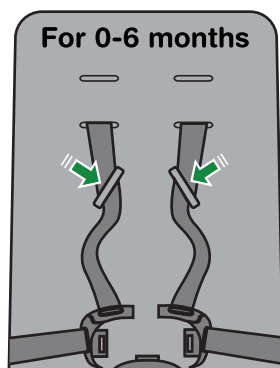

15 Plegar el cochecito

- (a) Pliegue la capota completamente hacia atrás.
(b) Levante la palanca en la parte trasera del cochecito con el pie (1) y luego empuje hacia abajo la palanca lateral (2).
(c) Empuje el cochecito hacia adelante desde las manijas.
(d) Una vez completamente plegado, utilice el pestillo situado en el lateral del cochecito para mantenerlo cerrado.

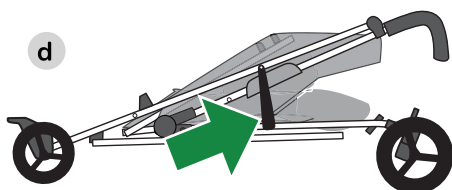
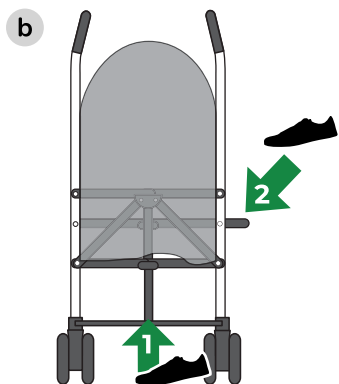
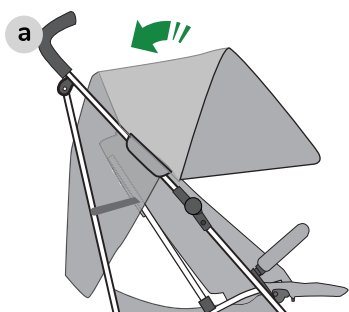

IMPORTANTE, CONSERVAR PARA FUTURA CONSULTA: LEA DETENIDAMENTE

Lea atentamente estas instrucciones antes de usarlas y consérvelas para consultarlas en el futuro.

Retire todos los embalajes y etiquetas no permanentes y deséchelos de forma segura antes de usar este producto. La seguridad de su hijo podría correr riesgo si no sigue estas instrucciones.

Este cochecito está diseñado para 1 niño desde 0 meses hasta un peso de 22 kg/36 meses.

ADVERTENCIA: Nunca deje a su hijo desatendido.

ADVERTENCIA: La carga desigual o excesiva de artículos sobre o dentro del cochecito puede hacer que el producto se incline y cause lesiones.

ADVERTENCIA: El peso máximo previsto dentro de la cesta de la compra es de 3 kg.

ADVERTENCIA: Asegúrese de que todos los dispositivos de bloqueo estén activados antes de su uso.

ADVERTENCIA: Para evitar lesiones, asegúrese de mantener alejado a su hijo cuando despliegue y pliegue este cochecito.

ADVERTENCIA: No deje que su niño juegue con este cochecito.

ADVERTENCIA: Utilice siempre el sistema de retención.

ADVERTENCIA: Compruebe que el cuerpo del cochecito o los dispositivos de fijación del asiento estén correctamente enganchados antes de su uso.

ADVERTENCIA: No coloque bebidas ni líquidos calientes en el portavasos.

ADVERTENCIA: Este producto no es apto para correr o patinar.

ADVERTENCIA: No inserte ningún colchón adicional en el cochecito.

ADVERTENCIA: No se deben utilizar accesorios que no estén aprobados por el fabricante.

ADVERTENCIA: ¡Este cochecito ha sido diseñado para un niño y se utilizará para el transporte de un solo niño!

ADVERTENCIA: Utilice siempre la correa de la entrepierna en combinación con el cinturón.

ADVERTENCIA: Este cochecito no sustituye a una cuna ni a una cama. Si su hijo necesita dormir, deberá colocarlo en una cuna o cama adecuada.

ADVERTENCIA: Sólo se utilizarán piezas de repuesto suministradas o recomendadas por My Babiie.

ADVERTENCIA: Cualquier carga sujeta al asa y en la parte posterior del respaldo y en los lados del cochecito afectará la estabilidad del cochecito.

ADVERTENCIA: El dispositivo de estacionamiento deberá estar activado al colocar y retirar a los niños.

Aprobado EN 1888-1:2018+A1:2022 y EN 1888-2:2018+A1:2022

- Compruebe periódicamente que los frenos, ruedas, pestillos, elementos de conexión, correas
Los sistemas y las costuras funcionan correctamente.
- No esponga el cochecito a la luz solar intensa.
- Limpiar únicamente con esponja.
- Después de usarlo bajo la lluvia o la nieve, se deben lubricar las ruedas y secar el cochecito para evitar óxido.
- Cuide, limpie y revise este cochecito con regularidad.
- No utilice accesorios que no hayan sido aprobados por el fabricante.

La seguridad de tu hijo es tu responsabilidad.

Si tiene algún problema con este producto o necesita piezas de repuesto, visite www.mybabiie.com/support

Registre su producto en: www.mybabiie.com/warranties

Pushchair Do's & Don'ts



Do use your brakes!

Ensure the parking brake is engaged during the loading and unloading of children & when the pushchair is stationary.

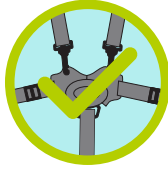

Do always use the restraint system!

Ensure that the child restraint system is correctly fitted at all times.



Do keep your pushchair clean and dirt free.

Use a clean white cloth, warm water and a mild detergent to keep your pushchair clean.



Do always keep two hands on the handles when pushing.

You could lose control of your pushchair if not steering with both hands.



Do follow manufacturers instructions when assembling and using your pushchair.

For safety, please refer to our instruction manuals or contact customer support if you're unsure.



Don't use your pushchair up and down stairs!

Don't use your pushchair up or down stairs or to bump kerbs.



Don't hang bags off the handles!

Bags and other items should not be hung from the handles as this can affect the stability of the pushchair.



Don't run or skate with your pushchair!

Our products are not suitable for running or skating.



Don't carry the stroller with baby inside!

Our pushchairs are not designed to be carried with your baby inside them.



Don't put hot drinks in the cup holder.

Hot drinks burn and can easily spill from the bottle holder.



Don't jetwash your pushchair.

Some jet washers are very powerful and could damage parts of your pushchair!



Don't leave your child un-attended in their pushchair.

Always keep your child and pushchair in view to avoid accidents.



Don't treat your pushchair like a trolley.

Don't load your pushchair up with all your shopping as they are not built for this purpose and could cause damage.



Don't use your pushchair as a bumper cart!

Damage can easily occur if your pushchair is knocked into other things.



Don't smoke around your pushchair.

We wouldn't want your pushchair or little one getting hurt or damaged!



Don't leave your pushchair unattended on extreme gradients.

Even with your brakes on your pushchair is at risk from tipping or sliding on extreme gradients!



Don't sit in the pushchair unless the user is under the guideline weight.

Our pushchairs are designed to hold a maximum weight. If exceeded this will cause damage!



Do enjoy your My Babie product!

Go out and have fun adventures with your little one!

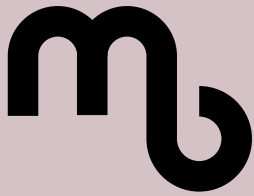

Register your product

www.mybabiie.com/warranties

In the first instance of needing assistance please contact your original place of purchase.

This product qualifies for 12 month warranty when registered through our website

mybabiie.com



My Babiie



@MyBabiieOfficial



My Babiie



@mybabiie_official



@MyBabiie

My Babiie Ltd, Paddock Wood, Kent, TN12 6EN

My Babiie EU , Generaal Vetterstraat 76A, 1059 BW Amsterdam, The Netherlands