

TANK M1 ASSEMBLY GUIDE

VERSION: XTTM1-RPH-101

PART #: 5706201-B

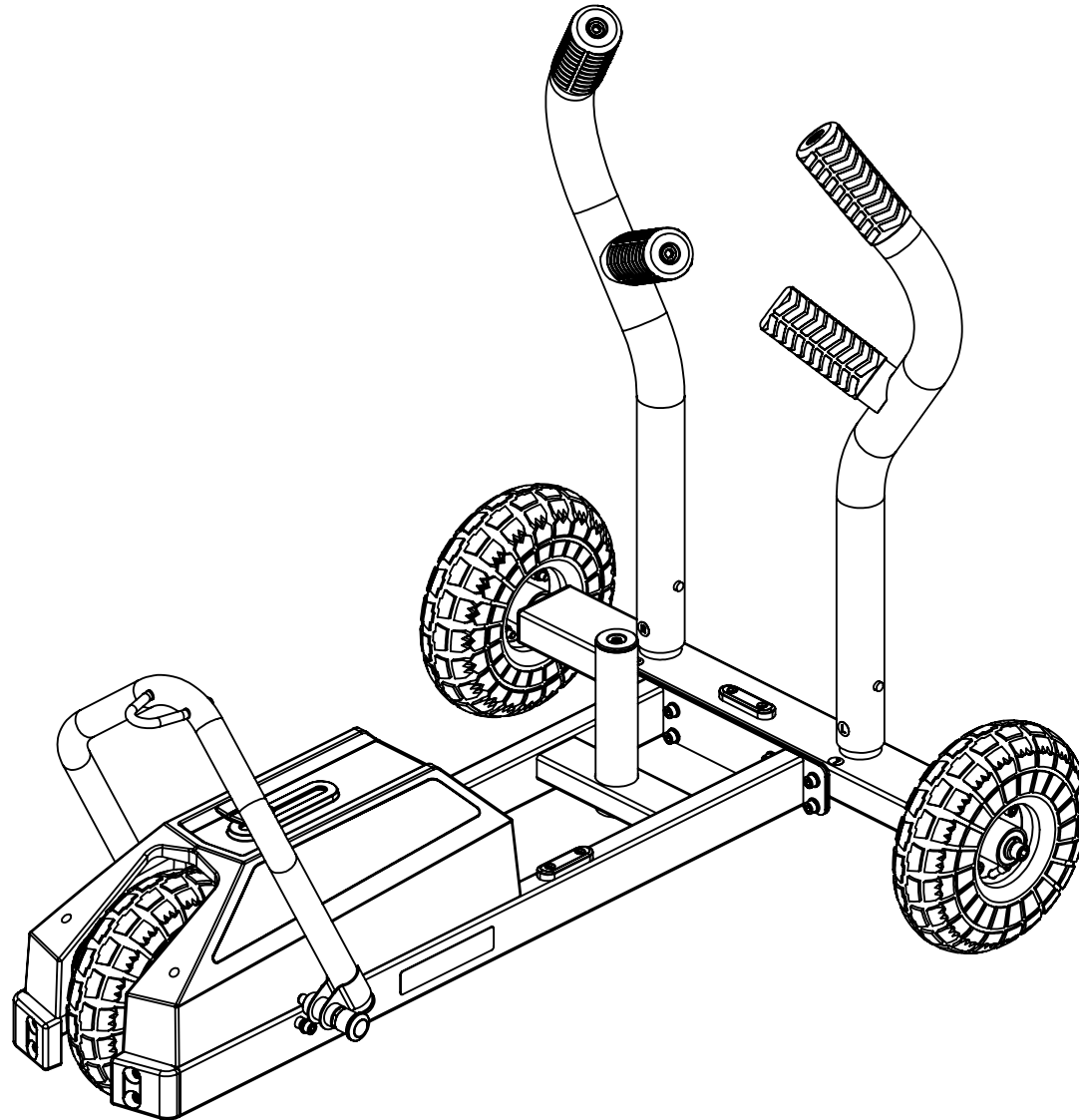

TORQUE USA

ITEM	PART NUMBER	DESCRIPTION	QTY
1	5661401	ASSY, CHASSIS WITH BRAKE SYSTEM	1
2	5661501	ASSY, REAR FRAME	1
3	2024401	WASHER, 8.4MM X 16MM X 1.8MM CLEAR ZINC	8
4	2009801	SCREW, M8-1.25 X 20L SOC HD GR 12.9	8
5	2010801	WASHER, STEEL 12.7 ID-25 OD-2 THK CLEAR ZINC	2
6	5654501	ASSY, REAR WHEEL 10" DIA X 3" WIDE	2
7	2010901	WASHER, LOCK M12 SAE ST ZN	2
8	2011301	SCREW, M12-1.75 X 30L SOC HD GR 12.9 CLEAR ZINC	2
9	56930PA	PTD ASSY, RH PUSH HANDLE	1
10	56931PA	PTD ASSY, LH PUSH HANDLE	1
11	57144PA	PTD ASSY, UPPER MOUNT	1
12	57145PA	PTD ASSY, LOWER MOUNT (OPTIONAL)	1
13	2001101	WASHER, FLAT 3/8 SAE ST ZN	8
14	5617001	V-STRAP, TANK (OPTIONAL)	1
15	5560801	ASSY, TANK TOW ROPE (OPTIONAL)	1
16	2031101	SCREW, 3/8" LAG X 2.5"L CLEAR ZINC	8

TOOLS NEEDED FOR ASSEMBLY:

- 10MM ALLEN WRENCH (INCLUDED)
- 6MM ALLEN WRENCH (INCLUDED)
- AIR PUMP WITH GAUGE
- PHILLIPS SCREW DRIVER

TABLE OF CONTENTS:

- TANK M1 ASSEMBLY: PAGES 3 - 5
- TANK M1 ADJUSTMENTS: PAGES 6 - 7
- TANK M1 OPERATION: PAGE 8
- OPTIONAL ATTACHMENTS: PAGE 9-10
- TANK M1 STORAGE (OPTIONAL): PAGE 11-14
- INSPECTION & LUBRICATION: PAGE 15
- SHROUD REMOVAL: PAGE 16
- CHAIN ADJUSTMENT: PAGE 17
- SAFETY AND WARNING NOTICES: PAGE 18

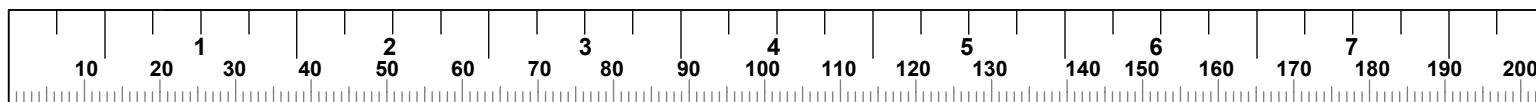

STEP 1

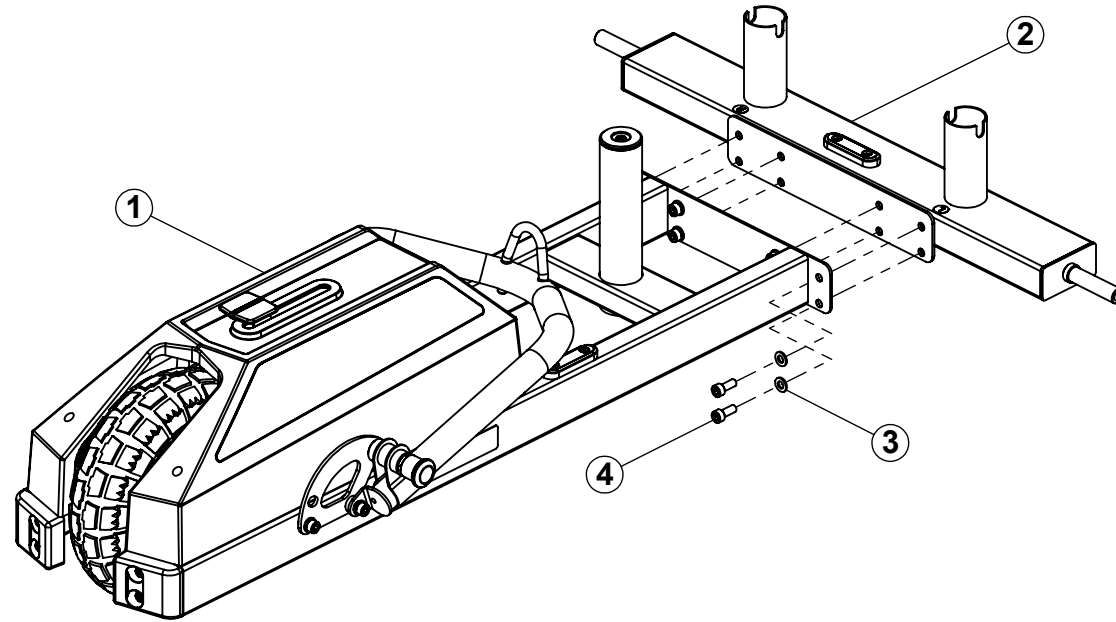

NOTE:

LOOSELY tighten bolt connections in this step.

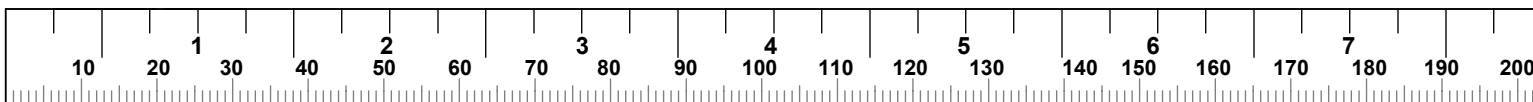

STEP 2

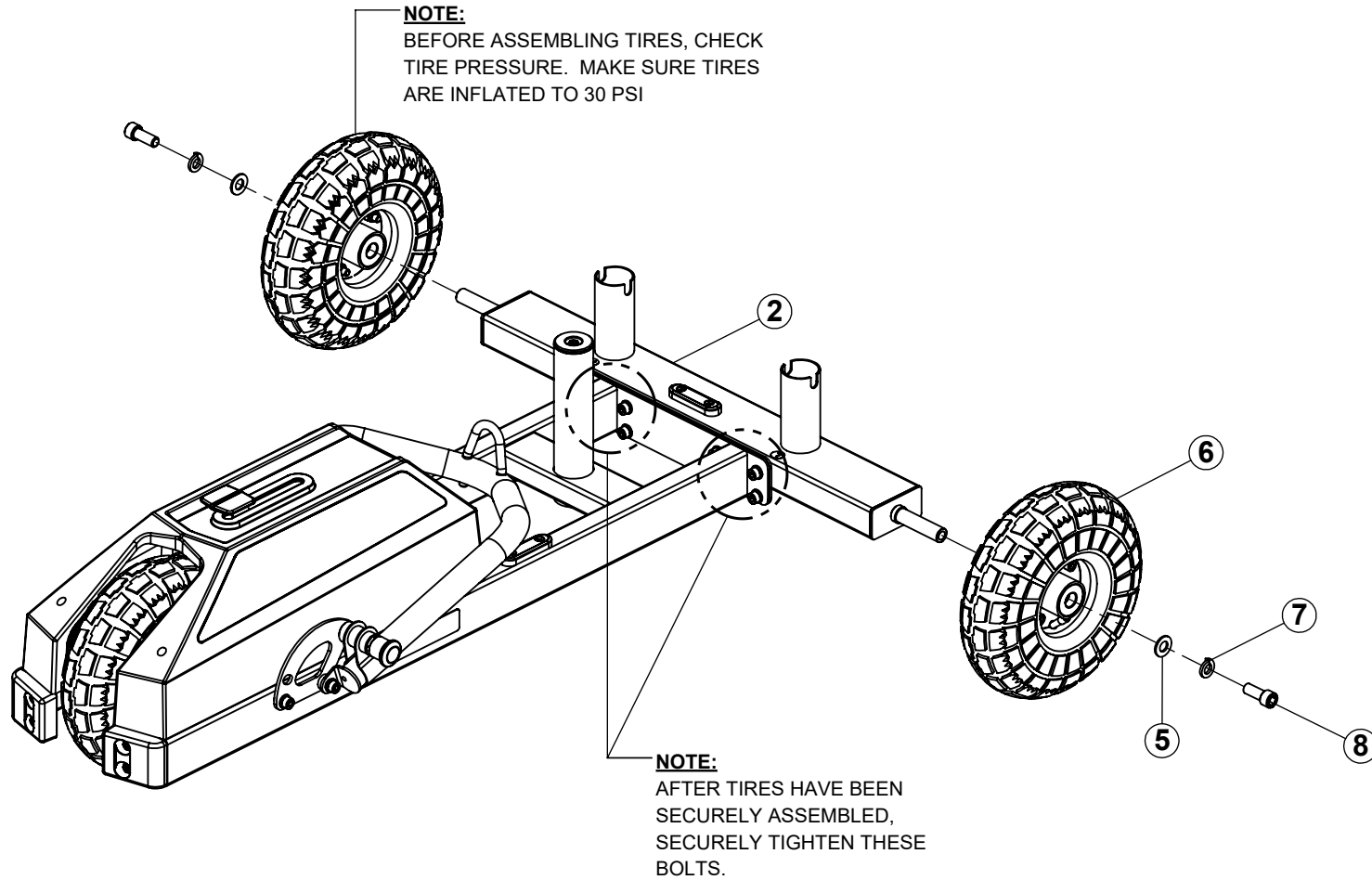

NOTE:

SECURELY tighten all bolt connections in this step and previous step.

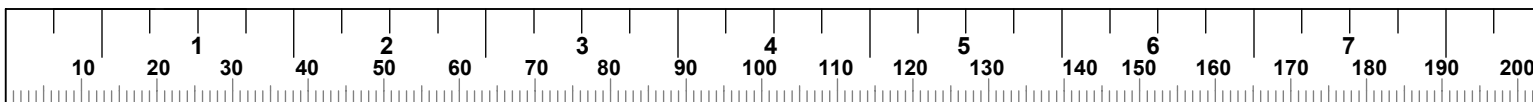

STEP 3

NOTE
MATCH THE "R" LABEL ON THE RIGHT PUSH
HANDLE WITH THE "R" LABEL ON THE REAR FRAME

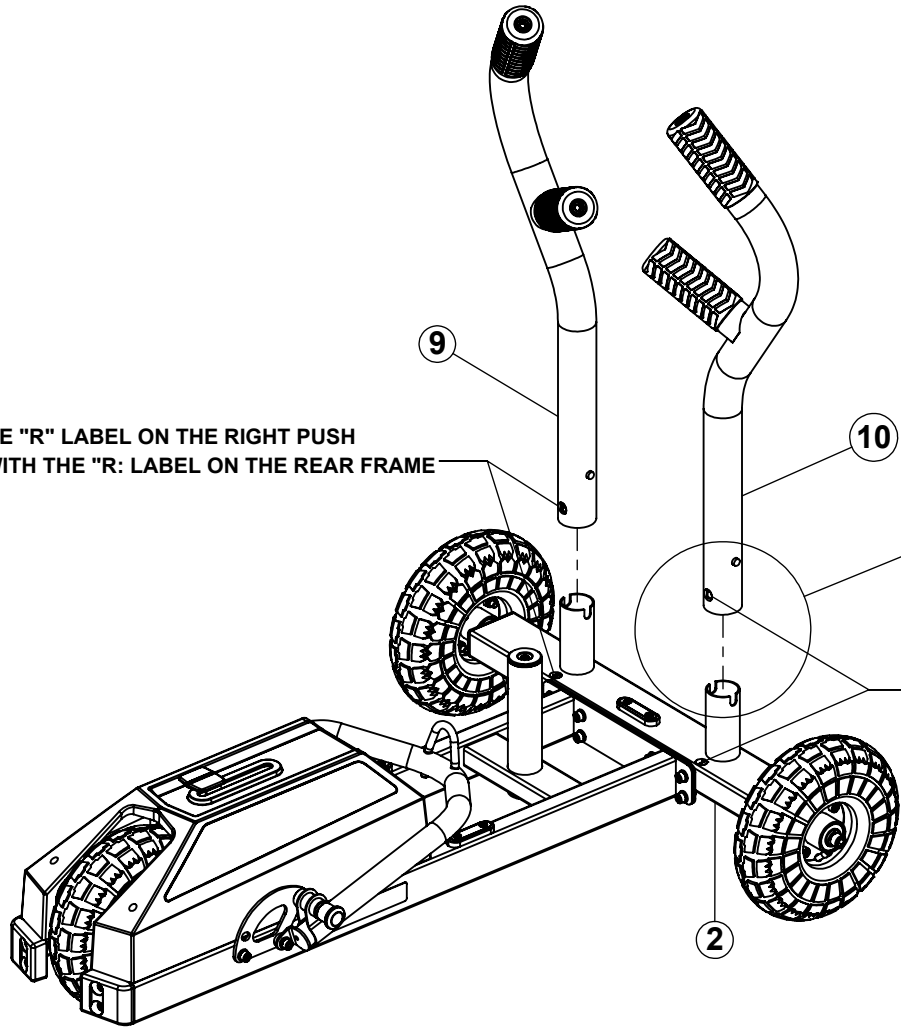

NOTE
MATCH THE "L" LABEL ON THE LEFT PUSH
HANDLE WITH THE "L" LABEL ON THE REAR FRAME

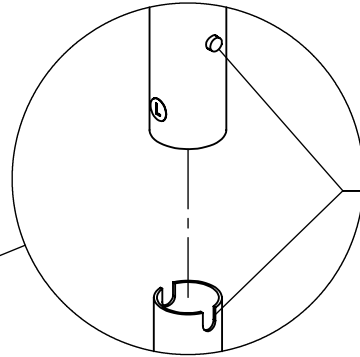

NOTE:
ALIGN THE PIN IN THE PUSH
HANDLES WITH THE SLOT IN
THE RECEIVER TUBE

TANK M1 RESISTANCE ADJUSTMENT

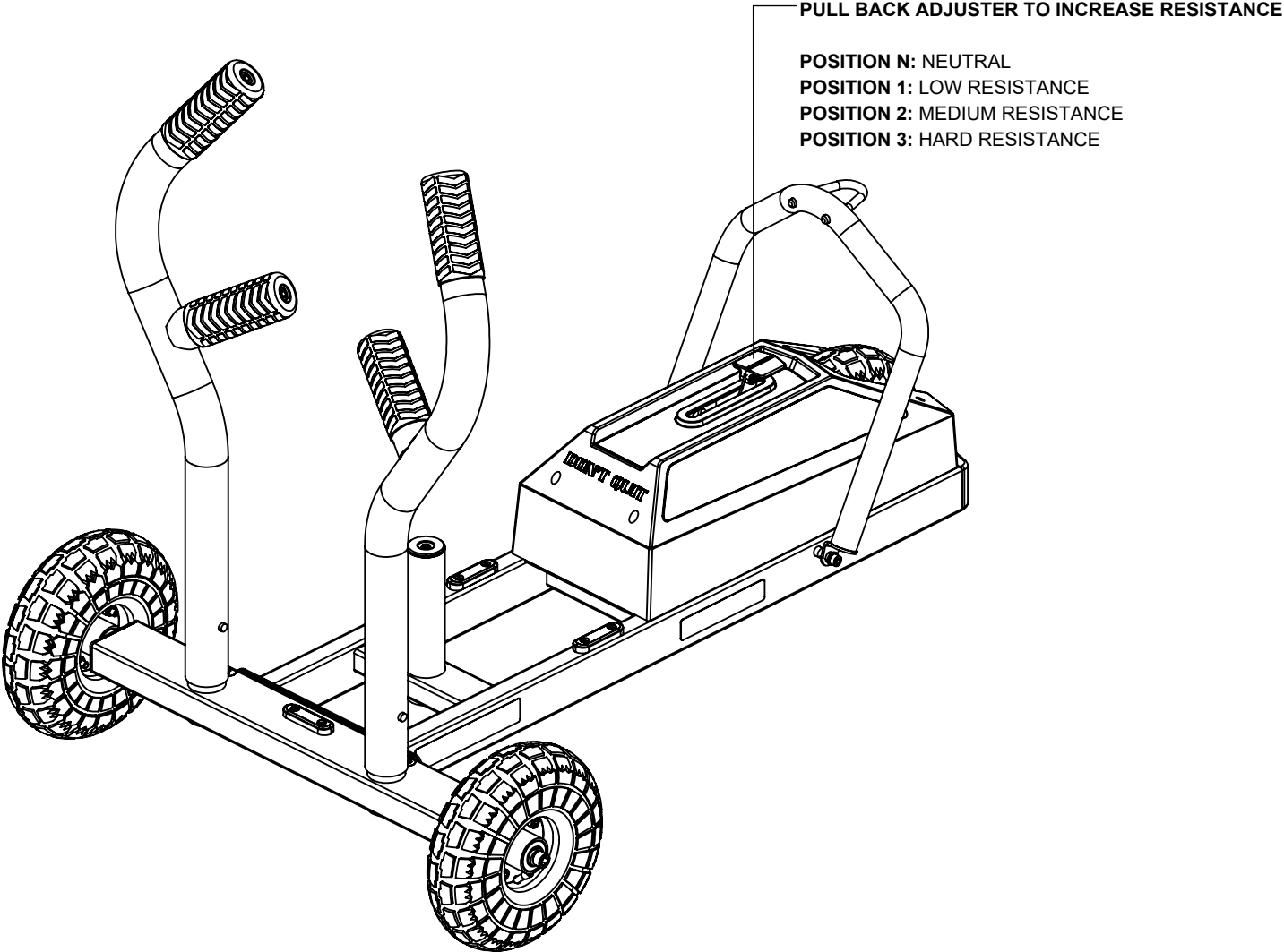

TANK M1 PUSH/PULL BAR ADJUSTMENT

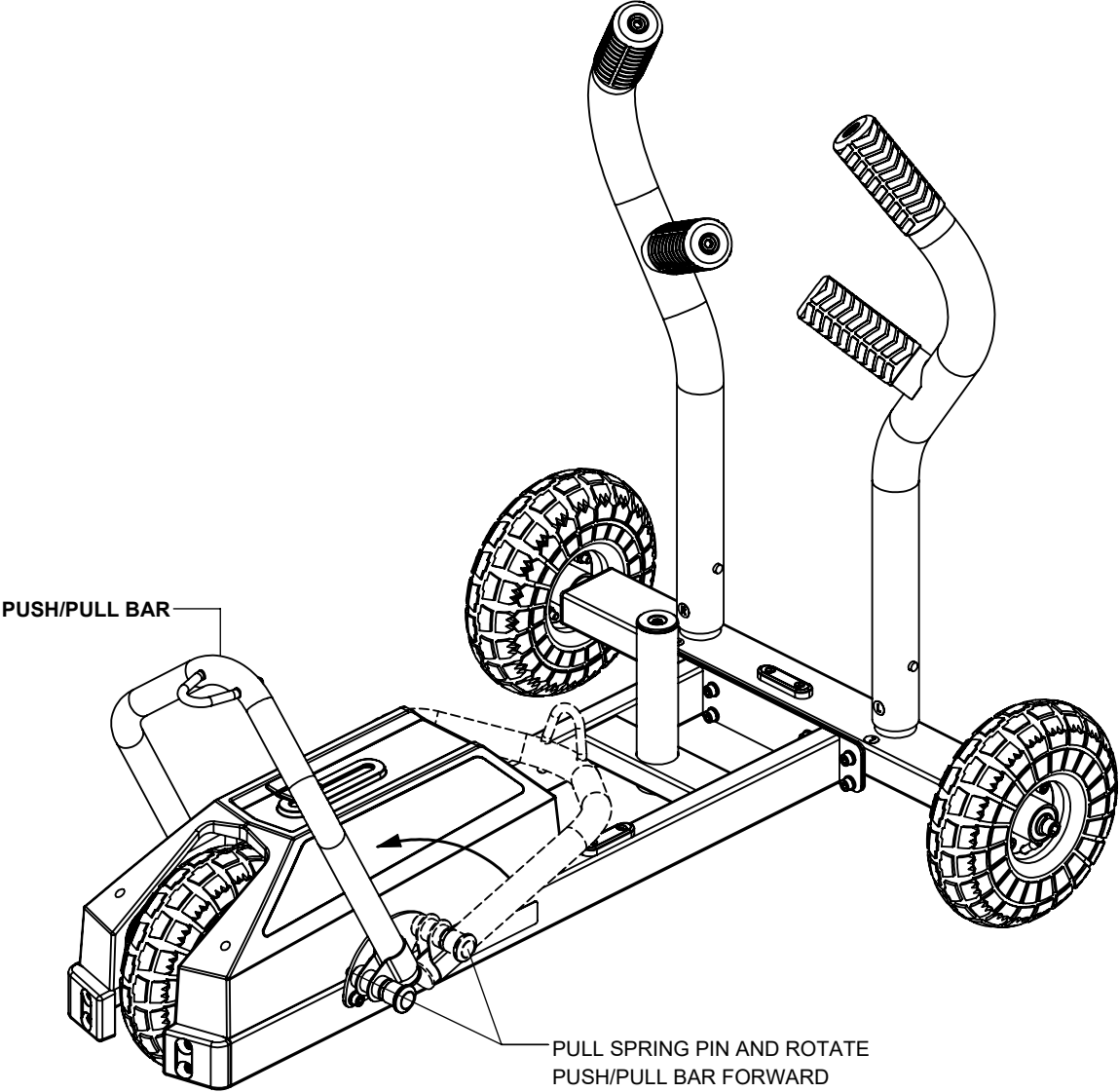

TANK OPERATION

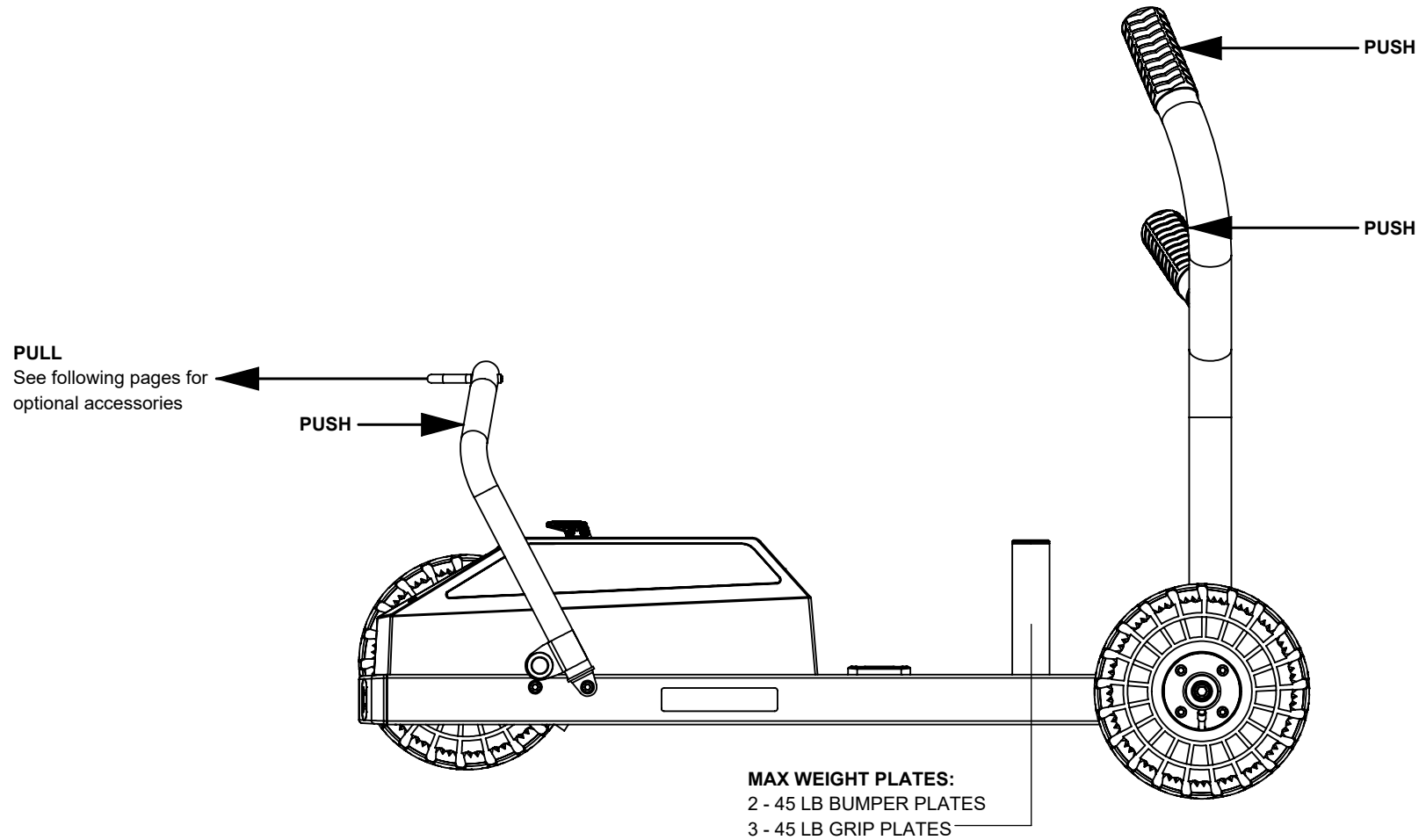

NOTE:
Weight plates are not included. Weight plates are only needed to prevent skidding and lifting of the back wheels. Adding weight does not affect the resistance.

V-STRAP ATTACHMENT (OPTIONAL)

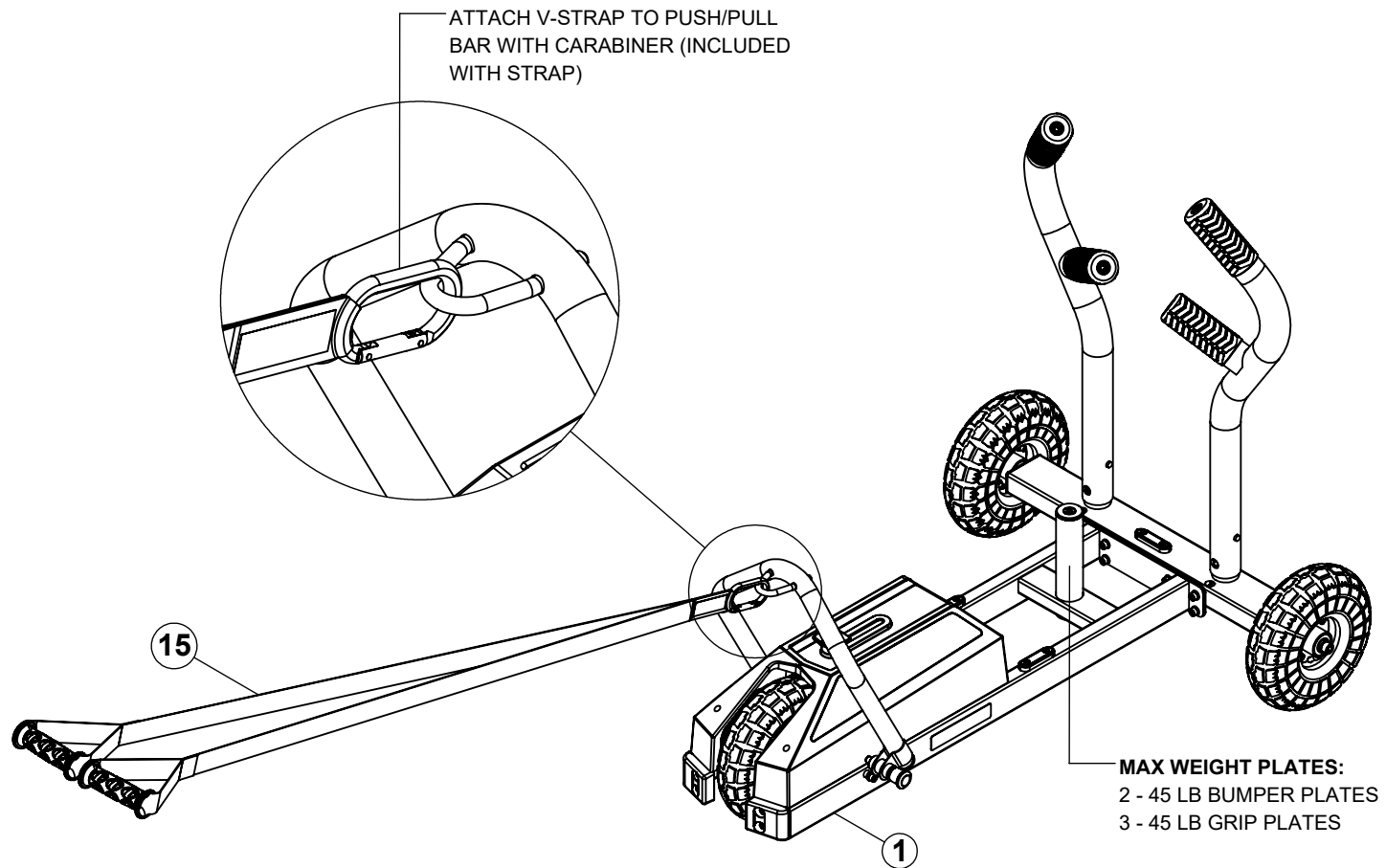

NOTE:

Weight plates are not included. Weight plates are only needed to prevent skidding and lifting of the back wheels. Adding weight does not affect the resistance.

To discover what accessories pair well with the TANK M1, visit our web site at: www.torquefitness.com/collections/tank-accessories. or by phone at 877-767-7835.

TOW ROPE ATTACHMENT (OPTIONAL)

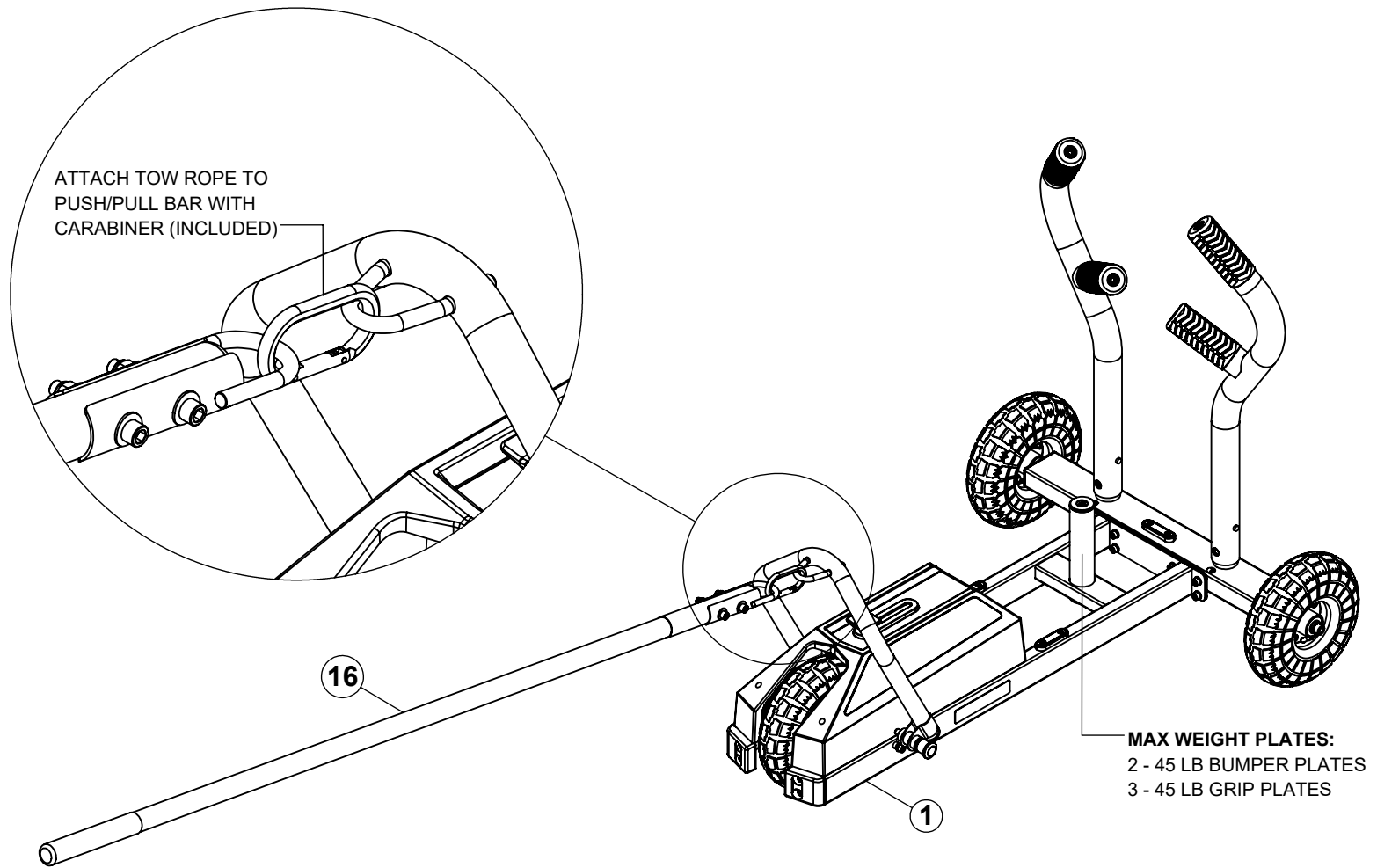

NOTE:

Weight plates are not included. Weight plates are only needed to prevent skidding and lifting of the back wheels. Adding weight does not affect the resistance.

To discover what accessories pair well with the TANK M1, visit our web site at: www.torquefitness.com/collections/tank-accessories. or by phone at 877-767-7835.

**XTWMH
WALL MOUNT HANGER (OPTIONAL)**

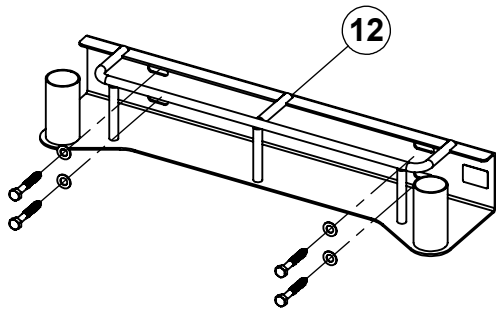
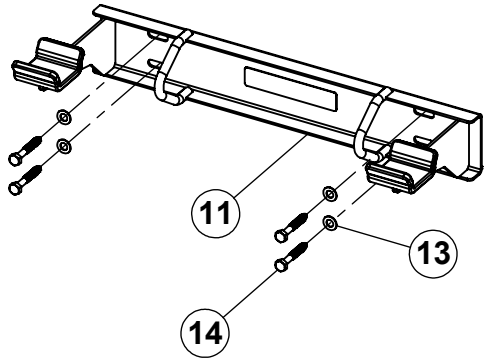

WARNING:
THE UPPER MOUNT **MUST** BE ANCHORED TO THE WALL USING FOUR WALL ANCHORS SUITABLE FOR THAT PARTICULAR WALL CONSTRUCTION.

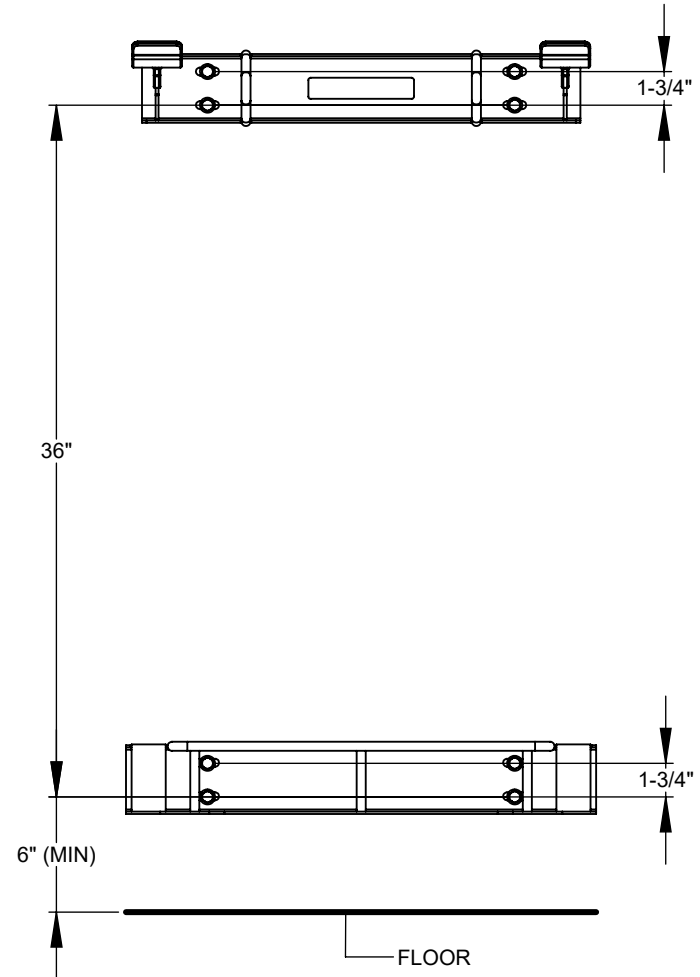

WARNING:
THE LOWER MOUNT **MUST** BE ANCHORED TO THE WALL USING FOUR WALL ANCHORS SUITABLE FOR THAT PARTICULAR WALL CONSTRUCTION.

NOTES:

The images above show the anchoring hardware used for attaching to typical walls with wood studs spaced 16" on center. The anchors used will depend on the wall construction. **NOTE: At least four anchoring locations must be used in each part.** The pull-out strength of the anchoring bolts used must be greater than or equal to 200 lbs. (91 kg)

SECURELY tighten bolt connections in this step.

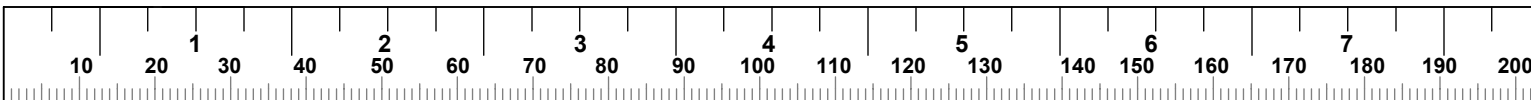

**XTWMH
WALL MOUNT HANGER (OPTIONAL)**

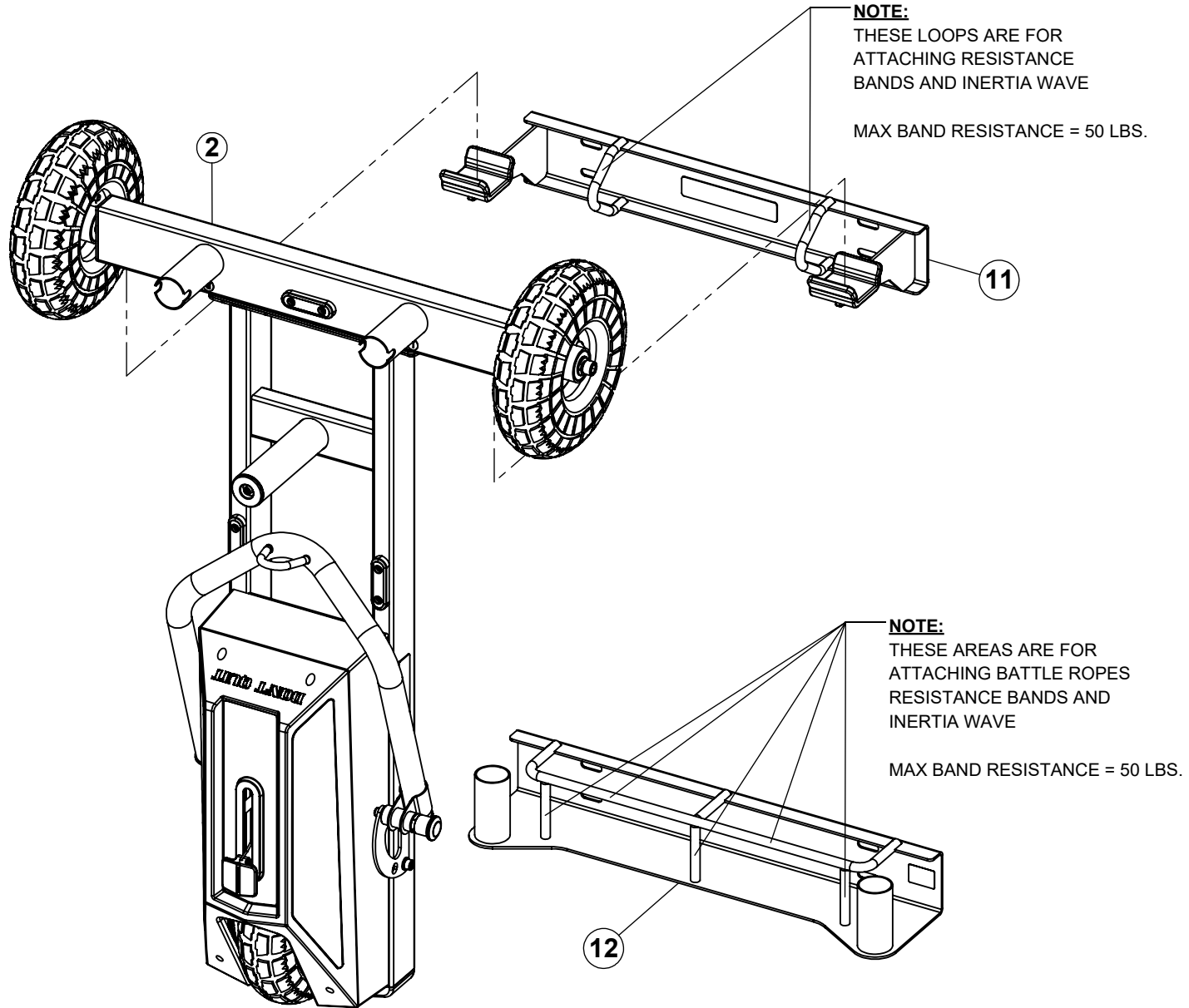

XTWMH
WALL MOUNT HANGER (OPTIONAL)

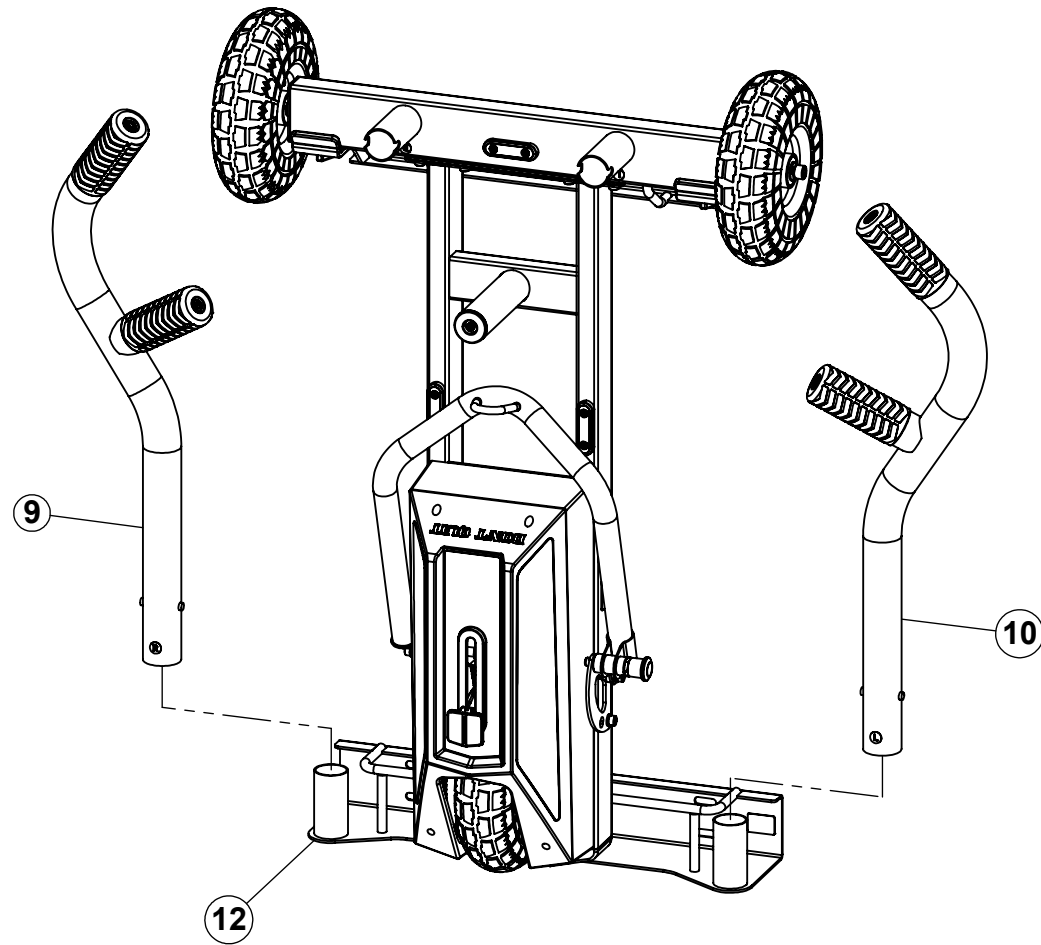

INSPECTION & LUBRICATION

INSPECTION:

ATTENTION:

PLEASE ENSURE THAT ALL TIRES ARE INFLATED TO 30 PSI. FAILURE TO DO SO MAY RESULT IN TANK VEERING DURING USE.

Once a month, check for loose bolts on frame and wheels. Tighten if necessary.

Once a month, remove shroud as shown on **PAGE 16** and check that the chain and sprockets are clean, free of rust, dust and grime. Make sure that the chain is properly lubricated.

If chain ever becomes loose, see **PAGE 17** to adjust chain.

Once a month, check tire pressure and inflate if needed.

LUBRICATION:

Once a month, the sprockets should be cleaned and the chain should be lubricated.

RECOMMENDED LUBRICATION: Use a Dry lubrication for indoor use, and wet lubrication for outdoor use. Most bicycle shops carry a variety of different lubricants and can recommend a lubricant based on the conditions where the TANK will be used.

 **#TorqueFitness #TorqueTANK**

 **<https://www.instagram.com/torquefitnessusa/>**

 **<https://www.youtube.com/c/TorqueFitness>**

 **<https://www.facebook.com/groups/thetankcommunity>**

SHROUD REMOVAL - STEP 1

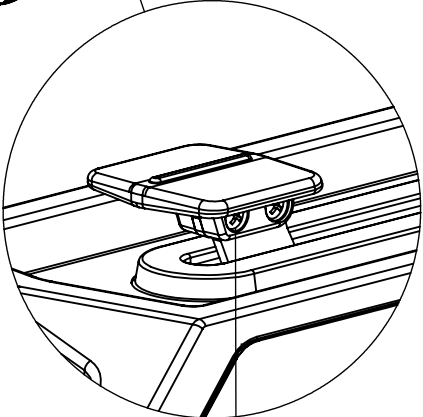
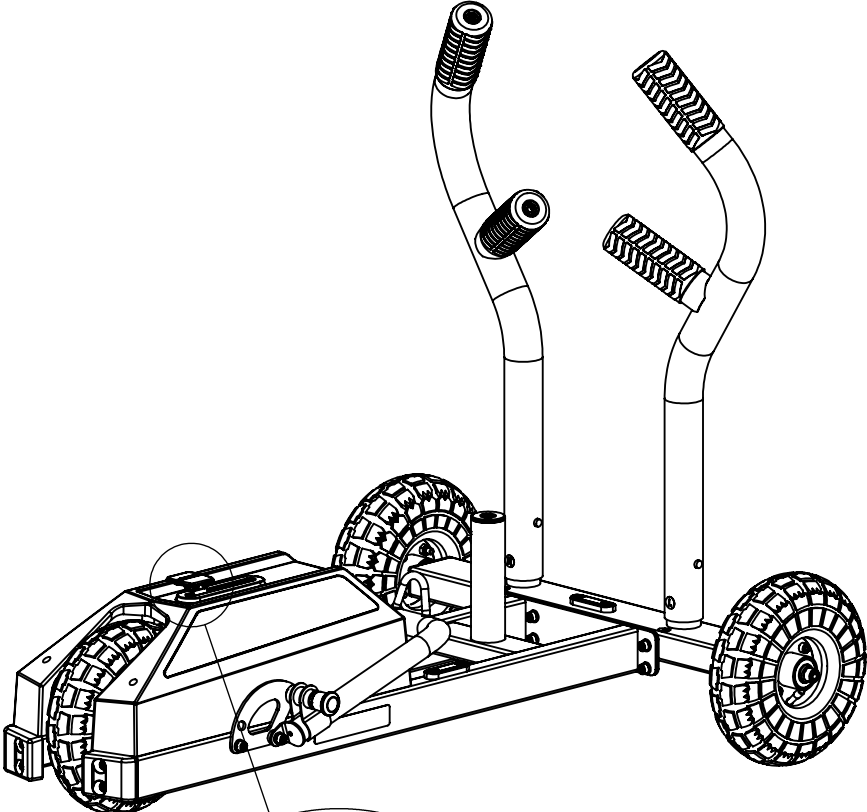

USE A PHILLIPS SCREW DRIVER TO LOOSEN AND REMOVE 2 SCREWS AND CAREFULLY REMOVE HANDLE.

SHROUD REMOVAL - STEP 2

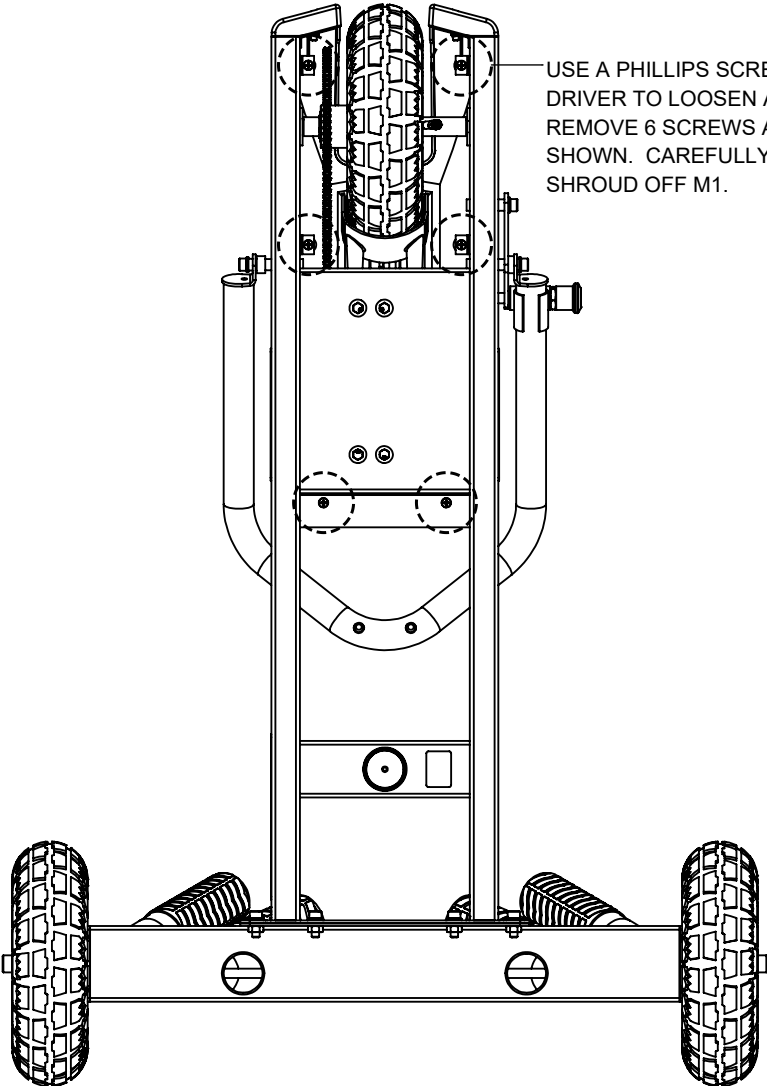

USE A PHILLIPS SCREW DRIVER TO LOOSEN AND REMOVE 6 SCREWS AS SHOWN. CAREFULLY LIFT SHROUD OFF M1.

BOTTOM VIEW

CHAIN ADJUSTMENT

TO SET THE CORRECT CHAIN TENSION
FOLLOW THESE STEPS:

1) TIP M1 BACK SO THAT IT RESTS ON THE
REAR WHEELS AND PUSH HANDLES. AS
SHOWN.

2) LOOSEN ALL FOUR BOLTS ONE FULL
TURN EACH. (BOLT SHOULD BE LOOSE
ENOUGH TO ALLOW THE BRAKE MODULE
TO MOVE). ALLOW GRAVITY TO PULL THE
BRAKE MODULE DOWNWARD REMOVING
THE EXCESS SLACK.

3) **SECURELY** RE-TIGHTEN THE FOUR BOLTS.

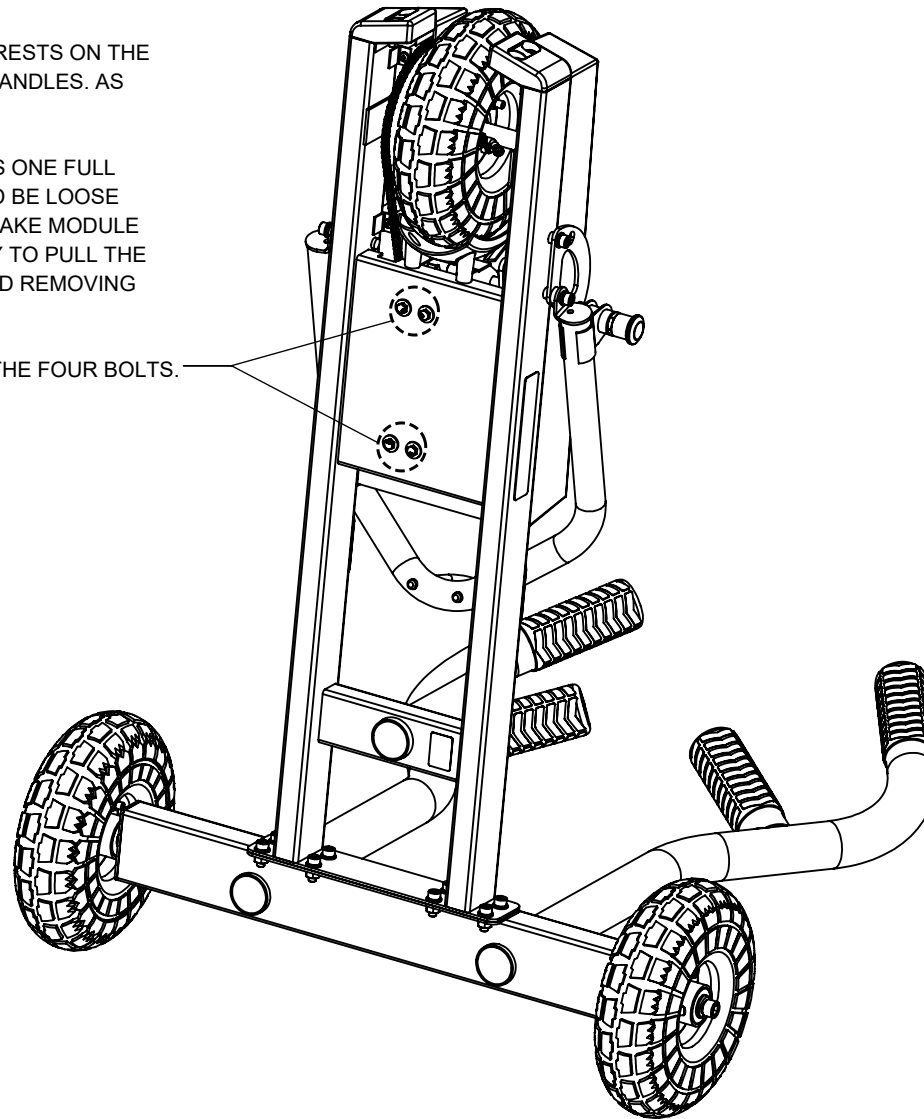

IMPORTANT SAFETY INSTRUCTIONS:

WARNING: The safety of this product can be maintained only if it is examined regularly for damage and wear. See inspection and lubrication section on page 13 for more details.

- **DO NOT** overinflate tires! All tires should be inflated to 30 PSI. Check air pressure periodically.
- Keep children away from the TANK M1 during use.
- Keep all loose clothing, hair and shoelaces away from moving parts.
- **DO NOT** attempt to use the TANK M1 for any purposes other than that for which it was intended.
- Wear shoes with rubber or high-traction soles. High heels, dress shoes, sandals or bare feet are not suitable for use with the TANK M1.
- **DO NOT** drop the front wheel down when turning the TANK M1 around. Carefully set the front wheel down - especially with weight plates on the weight horn.
- **DO NOT** place more than 135 LBS. on the weight horn of the TANK M1.
- **DO NOT** drop the weight plates onto the TANK M1. Doing so, may result in damage to the TANK M1.
- **DO NOT** use the TANK M1 in wet or slippery conditions.
- **DO NOT** push the TANK M1 while any accessories are attached to the push/pull bar.
- **DO NOT** stand or ride on the TANK M1.
- **DO NOT** use the TANK M1 without the shroud.

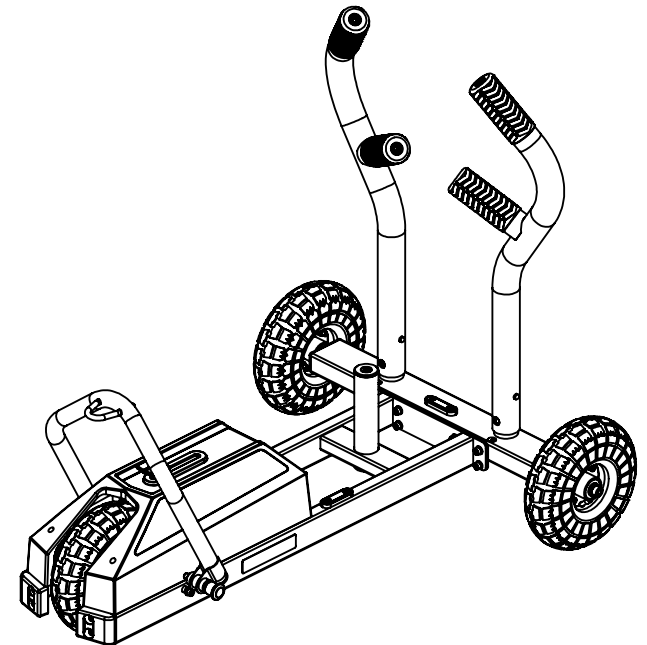

Torque Fitness
11201 Xeon Street NW Ste 101
Coon Rapids, MN USA 55448

www.torquefitness.com
Toll free: 1-877-TORQUE5 (1-866-664-9894)
or 763-754-7533 (8:30 am – 5:00 CST).

For sales: sales@torquefitness.com
For service: service@torquefitness.com