

POWER CAGE ASSEMBLY GUIDE

VERSION: XPC-104

PART #: 5516901-C

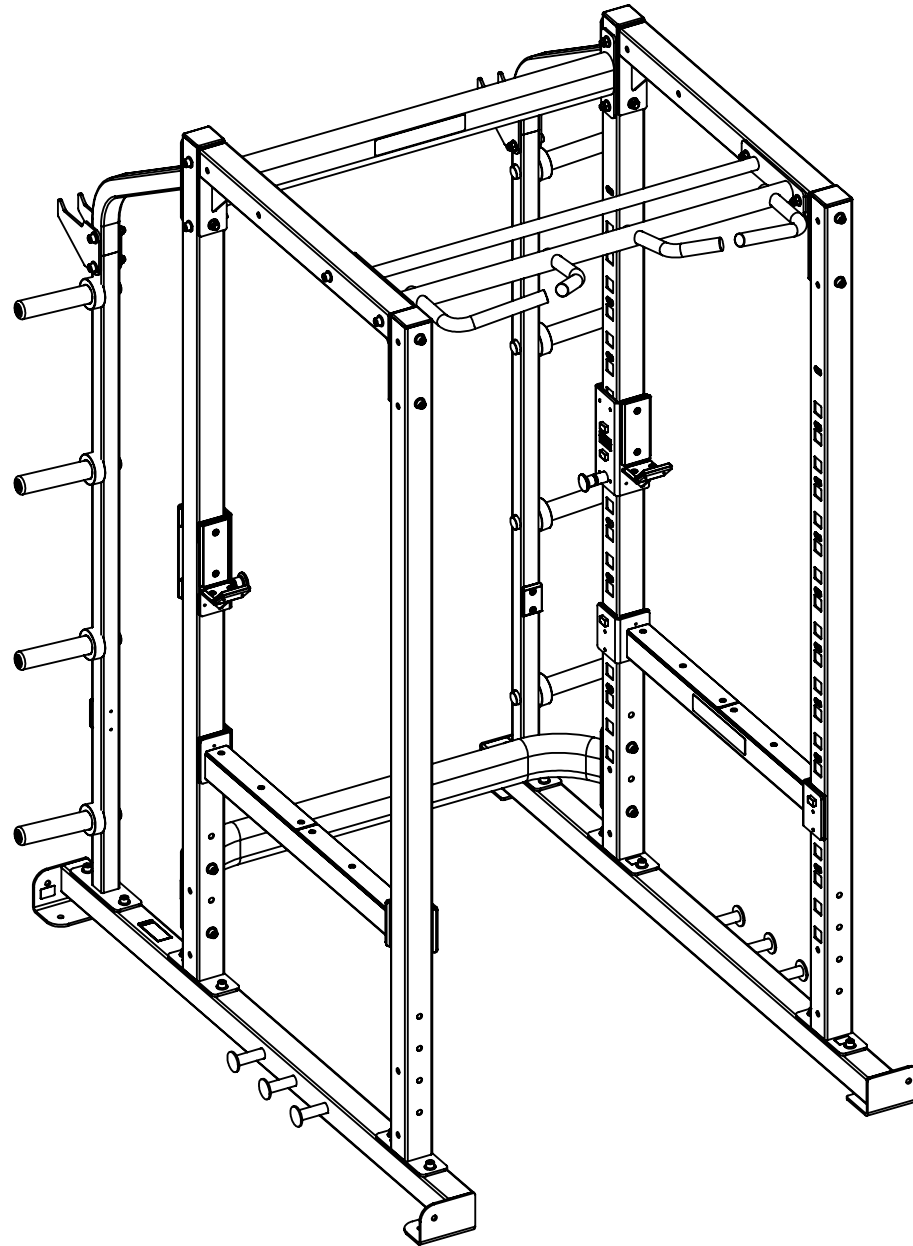

TORQUE USA

ITEM	PART NUMBER	DESCRIPTION	QTY
1	54120PA	PTD ASSY, BASE LEFT	1
2	55071PA	PTD ASSY, XPC UPRIGHT	4
3	55164PA	PTD ASSY, WEIGHT HORN UPRIGHT	2
4	2005815	BOLT, 1/2-13 X 4" (102mm) SOCKET HEAD	26
5	2001301	WASHER, FLAT 1/2 SAE ST ZN	68
6	2001401	NUT, 1/2-13 LK ST ZN	32
7	5473401	WLDMT, UPRIGHT SUPPORT	2
8	5516601	WLDMT, WEIGHT HORN UPRIGHT TOP	2
9	2006814	BOLT, 1/2-13 X 3-3/4" (95mm) SOCKET HEAD W/NP	2
10	2006815	BOLT, 1/2-13 X 4" (102mm) SOCKET HEAD W/NP	2
11	2005816	BOLT, 1/2-13 X 4-1/4" (108mm) SOCKET HEAD	2
12	5473101	PLATE, STORAGE HOOK CONNECTOR	4
13	2005812	BOLT, 1/2-13 X 3-1/4" (83mm) SOCKET HEAD	4
14	5412501	WLDMT, BASE RIGHT	1
15	5414601	WLDMT, LOWER CROSS SUPPORT	1
16	54143PA	PTD ASSY, UPPER CROSS SUPPORT	1
17	5413701	WLDMT, CHIN-UP	1
18	55069PA	PTD ASSY, BAR CATCH	2
19	54737PA	PTD ASSY, LEFT BAR SUPPORT	1
20	54742PA	PTD ASSY, RIGHT BAR SUPPORT	1
21	XRACK-6SX-101	XRACK 6' SINGLE CROSS (OPTIONAL)	1
22	2002401	NUT, 1/2 LW HT LK ST ZN (OPTIONAL)	2

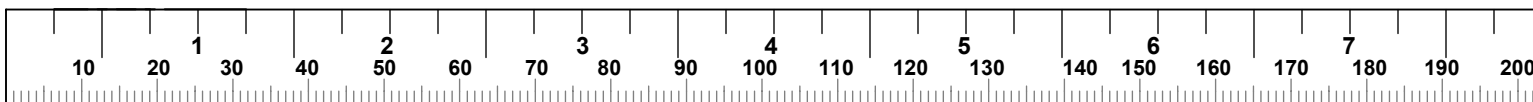
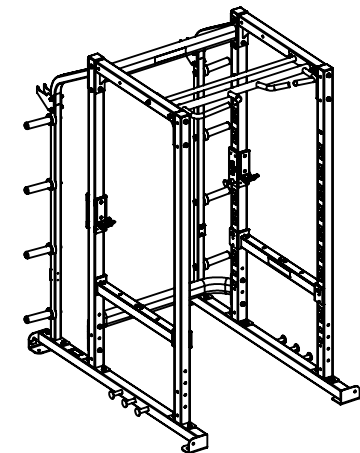

STEP 1

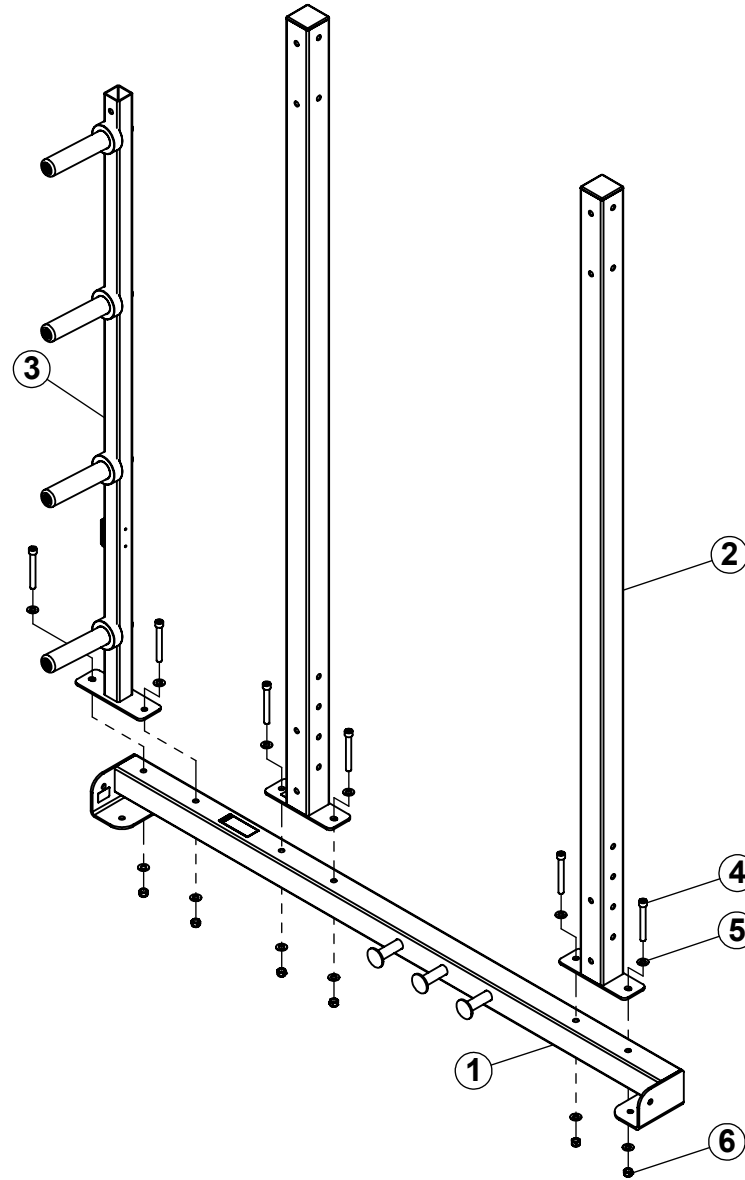

NOTE:

LOOSELY assemble bolt connections in this step.

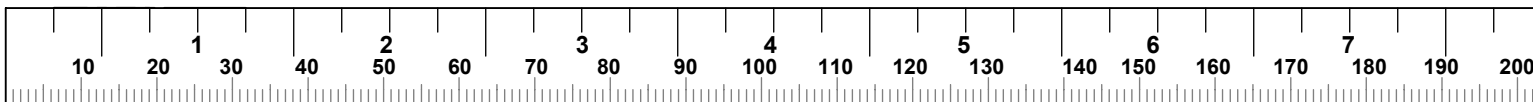

STEP 2

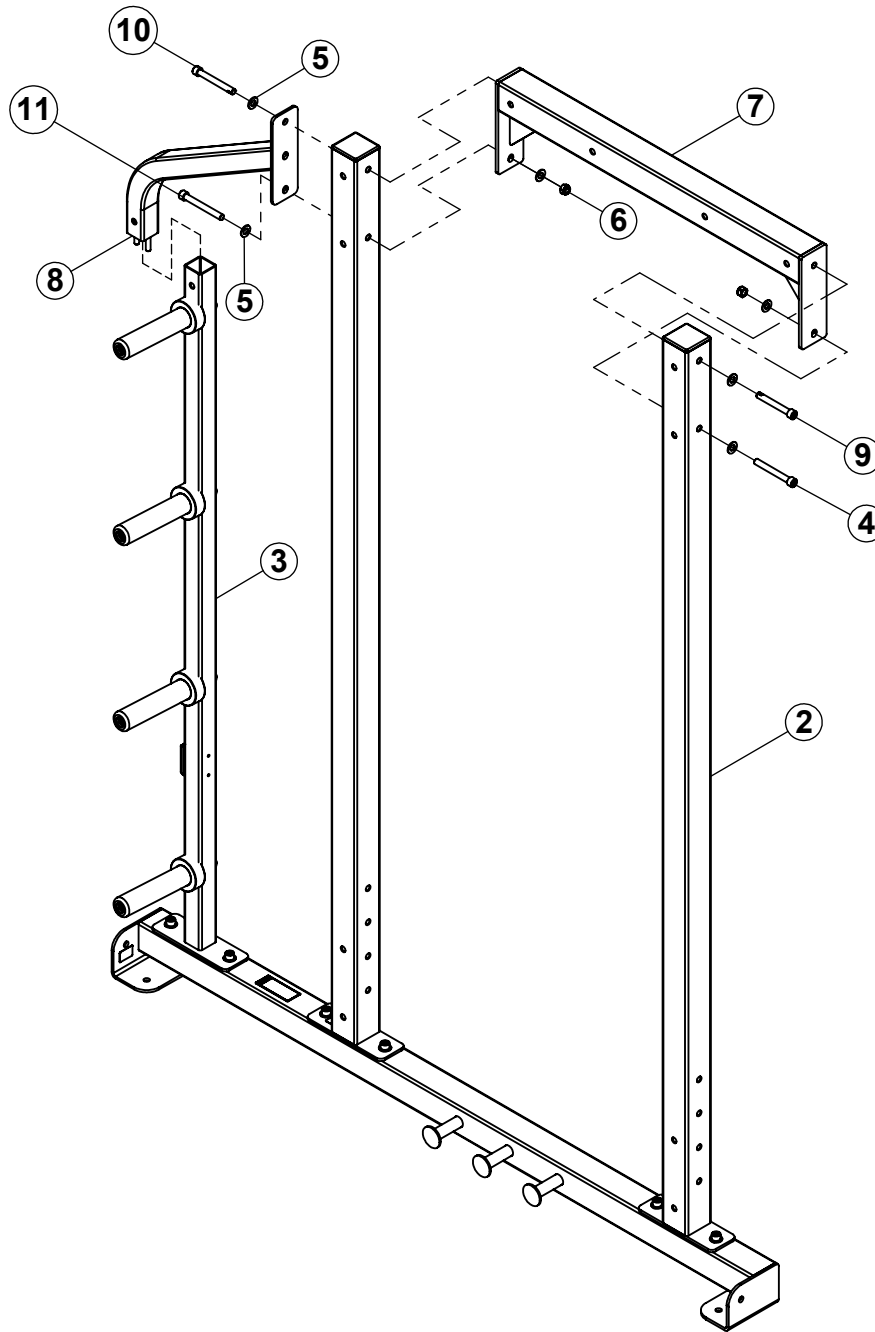

NOTE:

LOOSELY assemble bolt connections in this step.

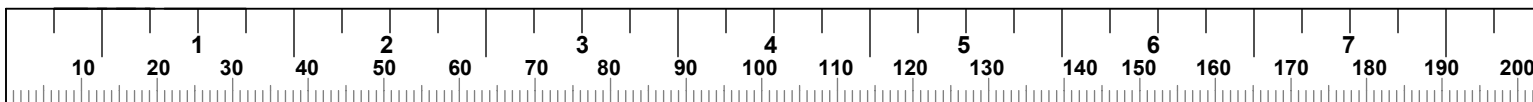

STEP 3

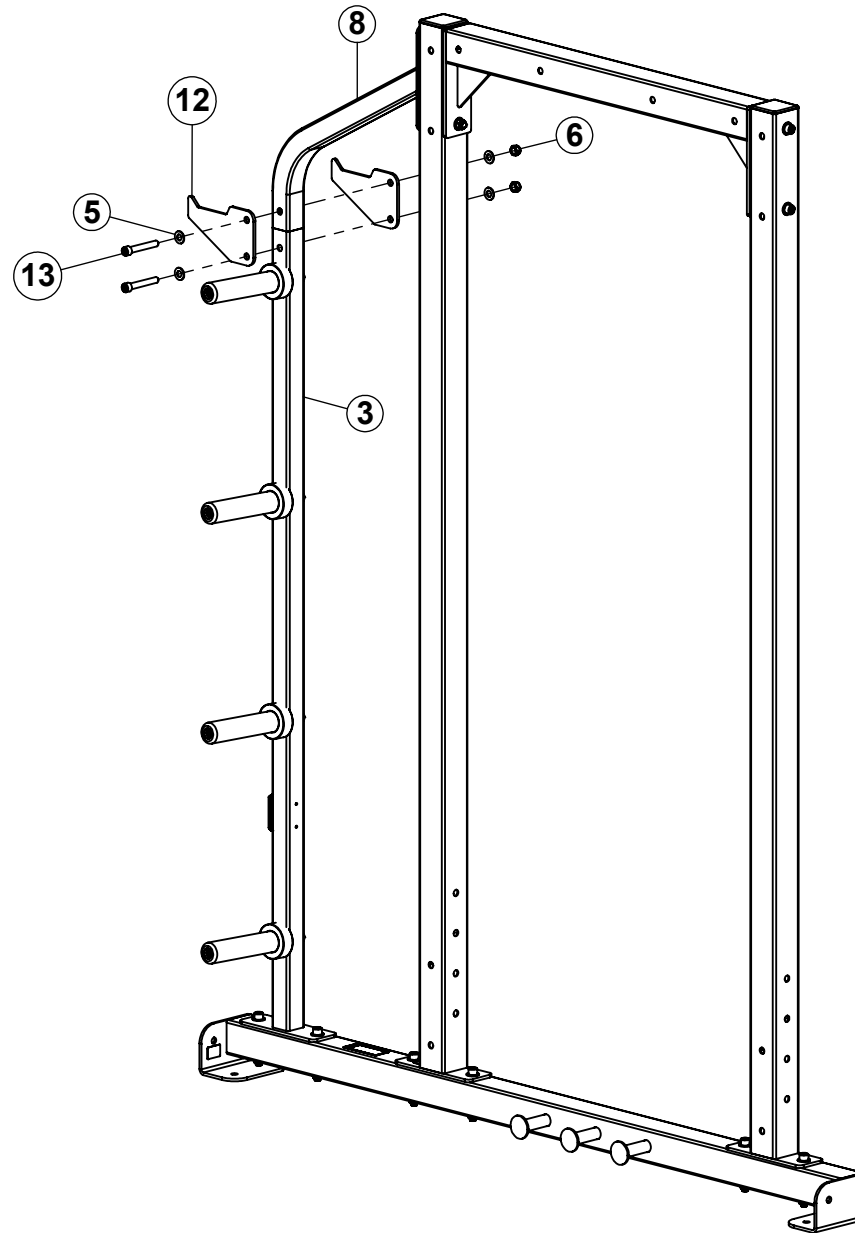

NOTE:

LOOSELY assemble bolt connections in this step.

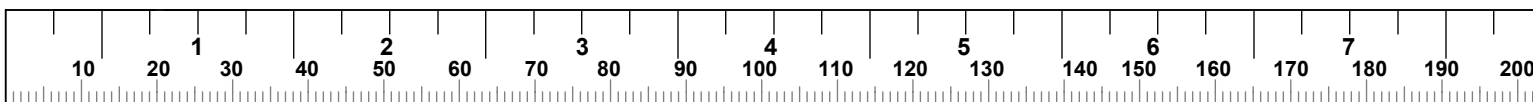

STEP 4

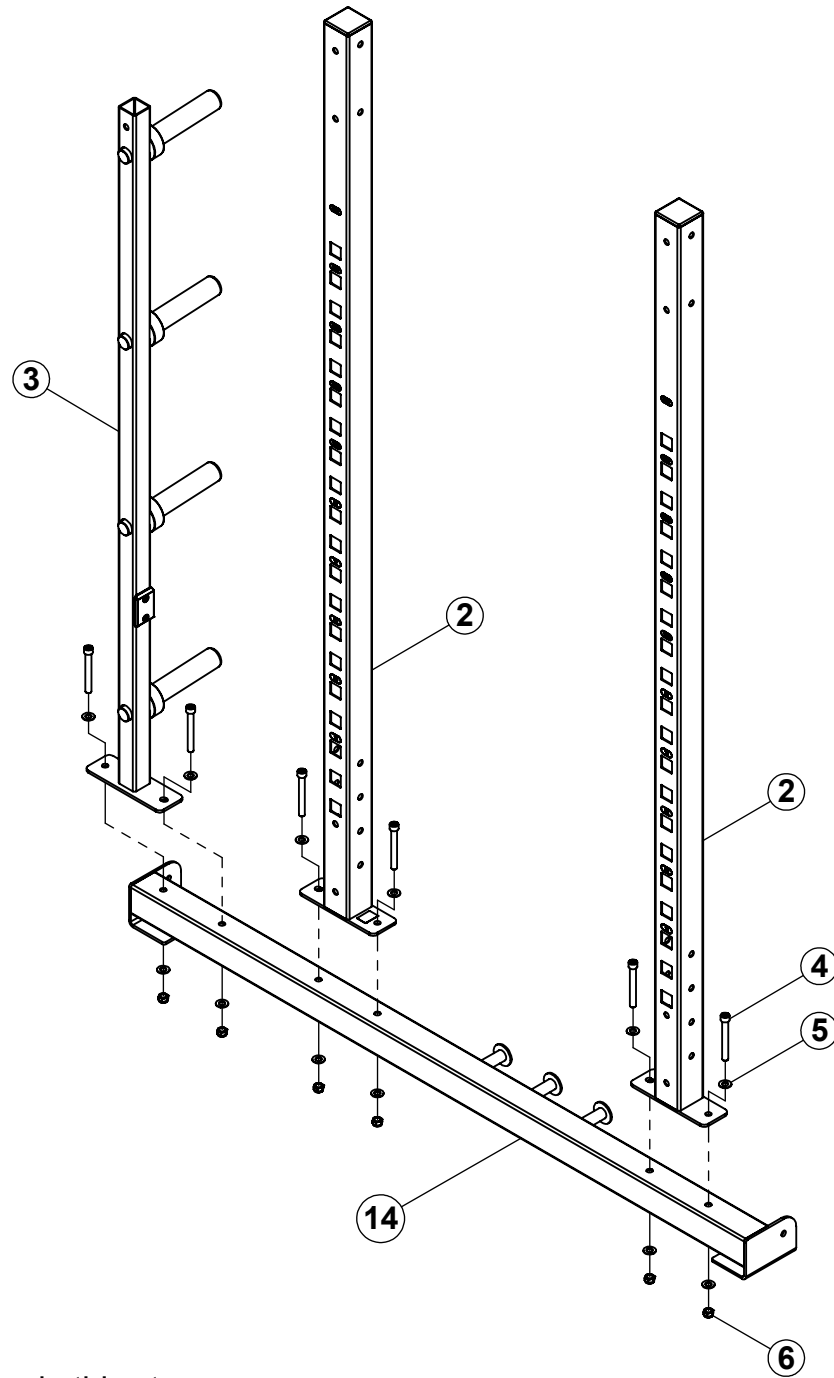

NOTE:

LOOSELY assemble bolt connections in this step.

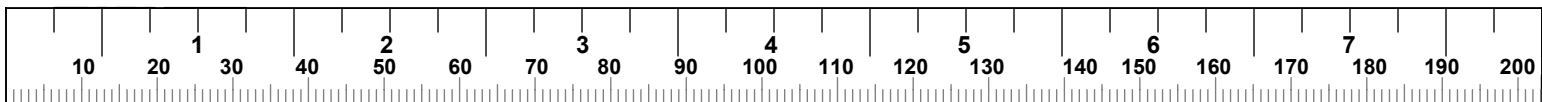

STEP 5

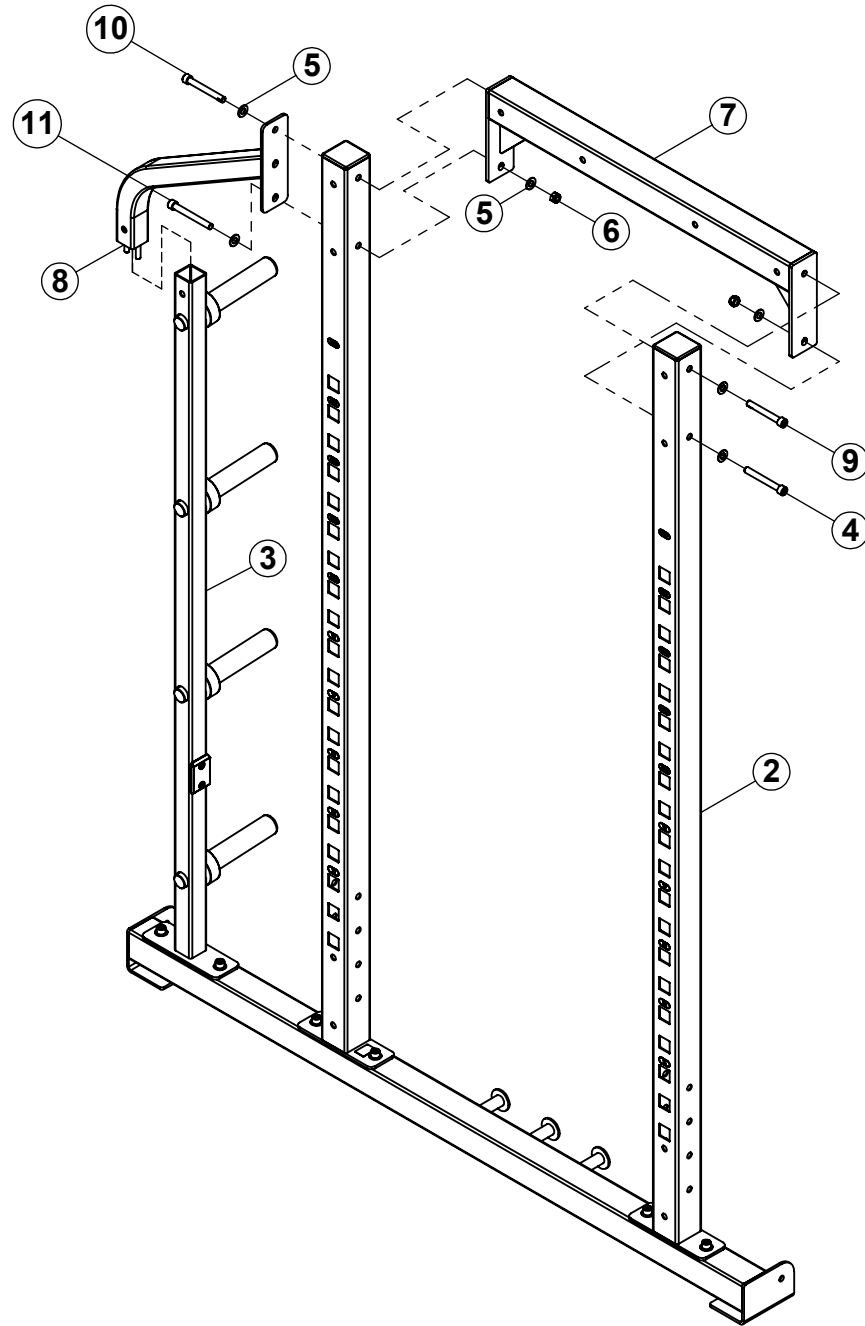

NOTE:

LOOSELY assemble bolt connections in this step.

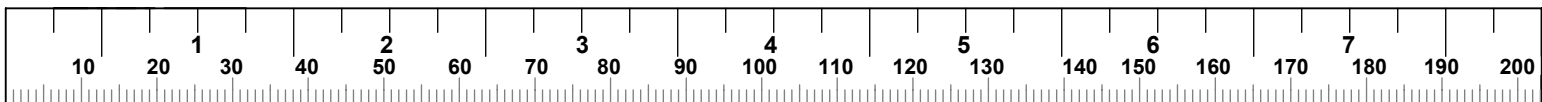

STEP 6

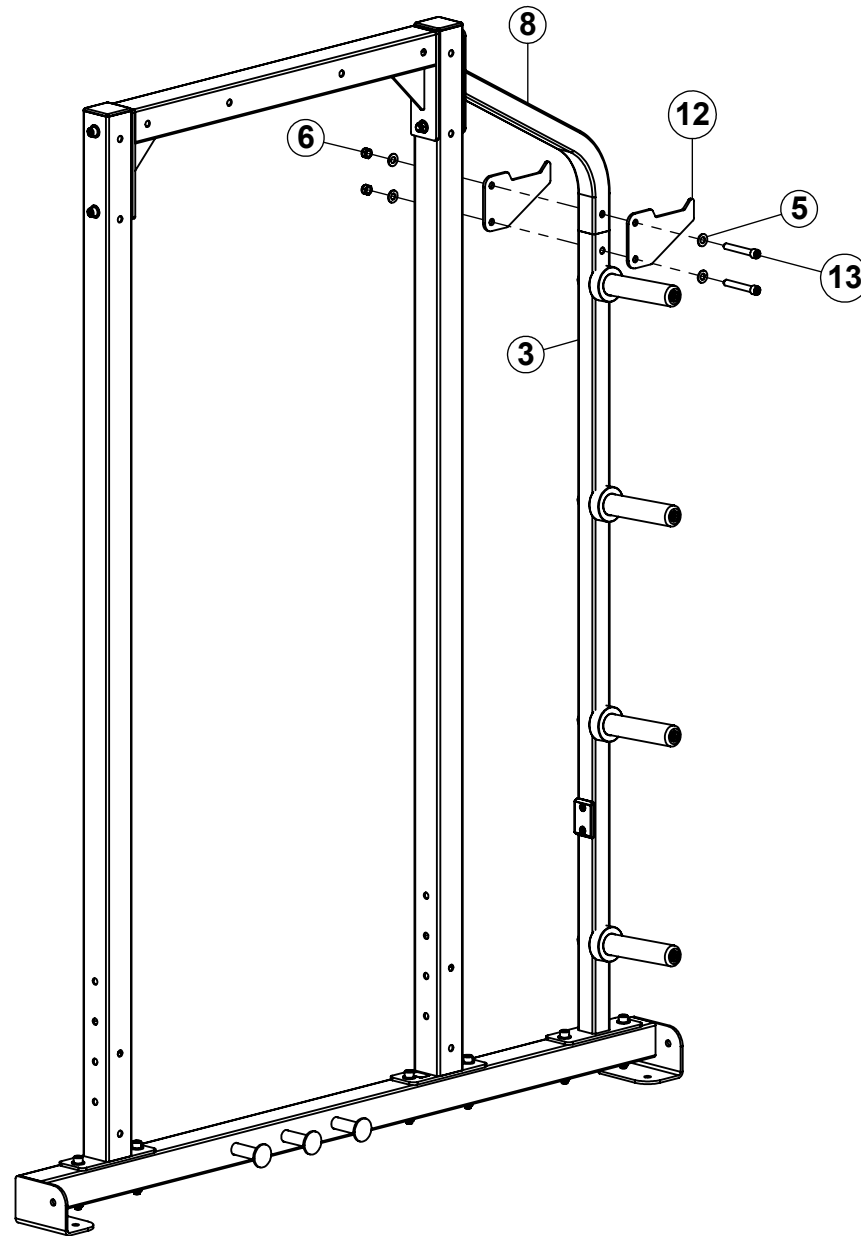

NOTE:

LOOSELY assemble bolt connections in this step.

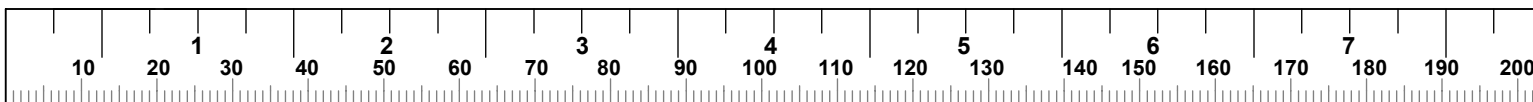

STEP 7

NOTE:

If a platform will be used, assemble item 15 to the upper set of holes on item 2.

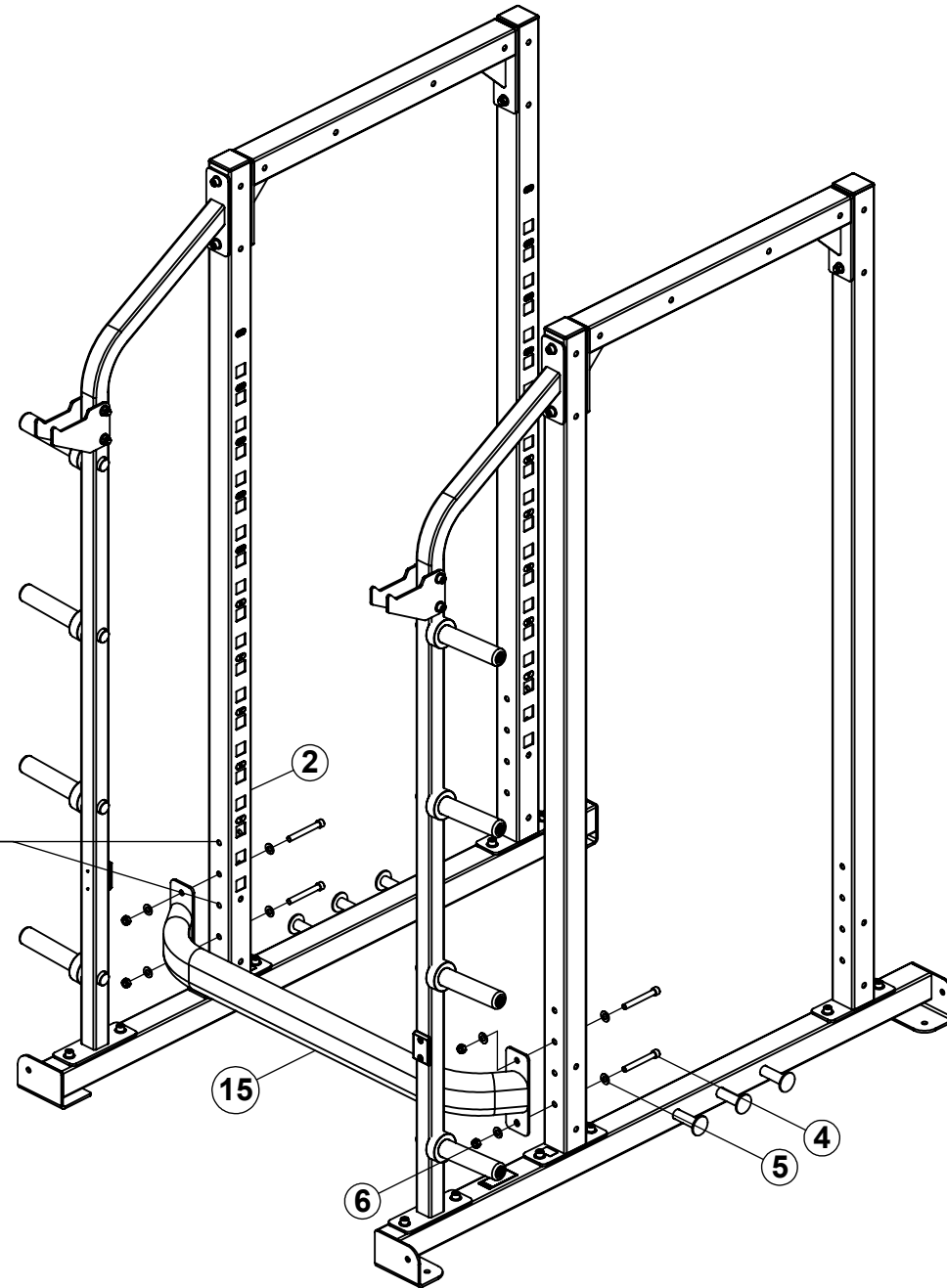

NOTE:

LOOSELY assemble bolt connetions in this step.

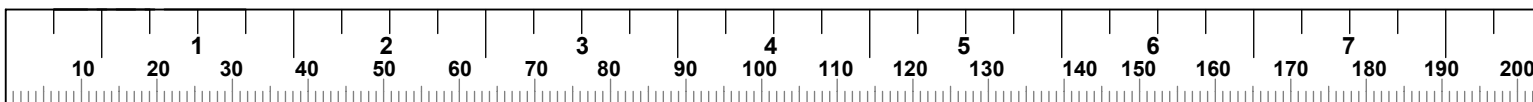

STEP 8

NOTE:

If more than one POWER CAGE will be joined together, leave this connection loose until step ?

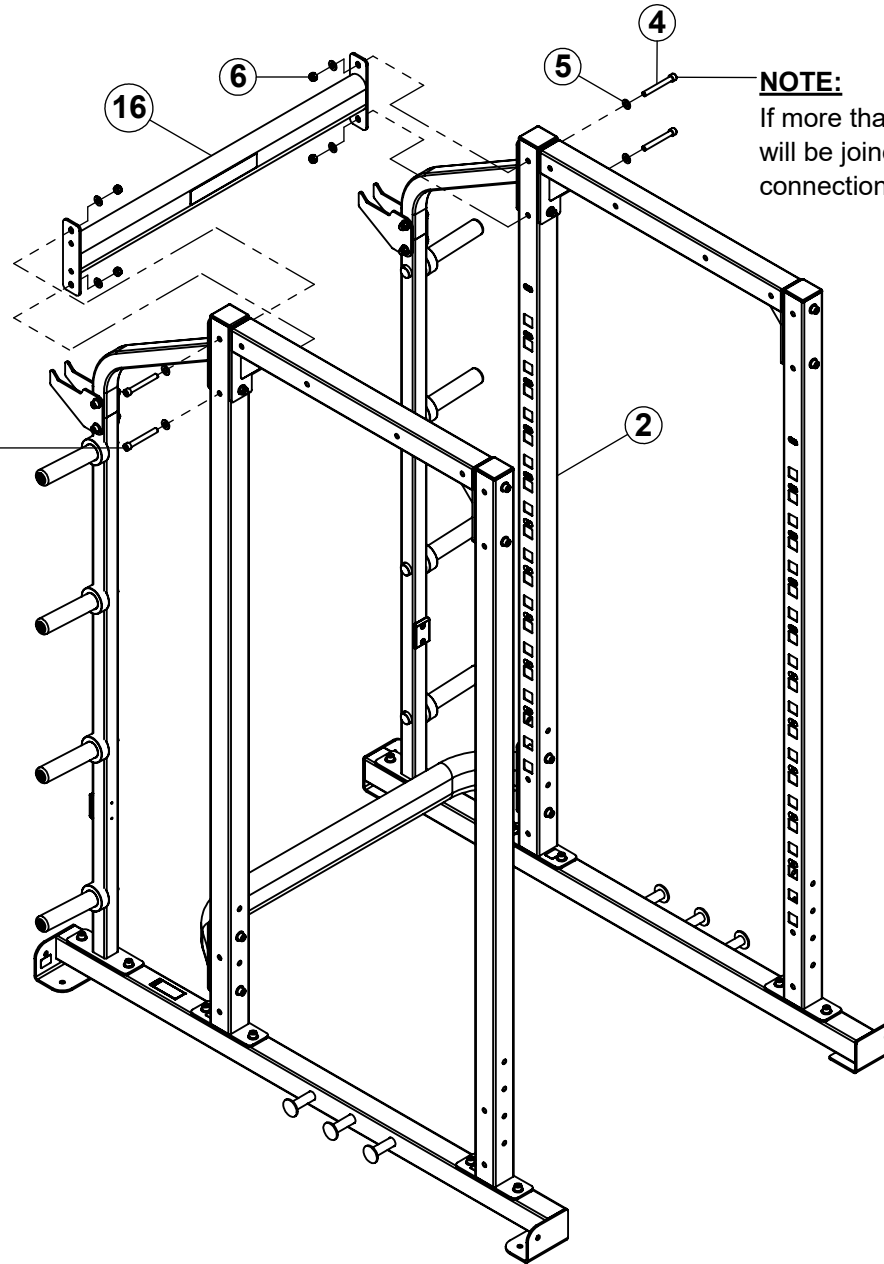

NOTE:

If more than one POWER CAGE will be joined together, leave this connection loose until step ?

NOTE:

LOOSELY assemble bolt connections in this step.

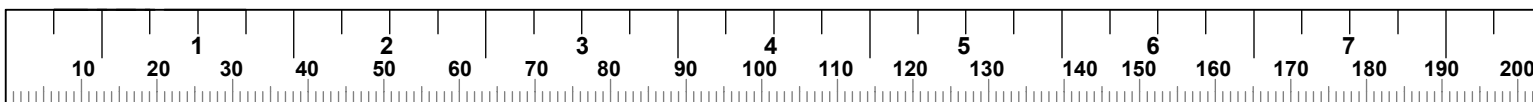

STEP 9

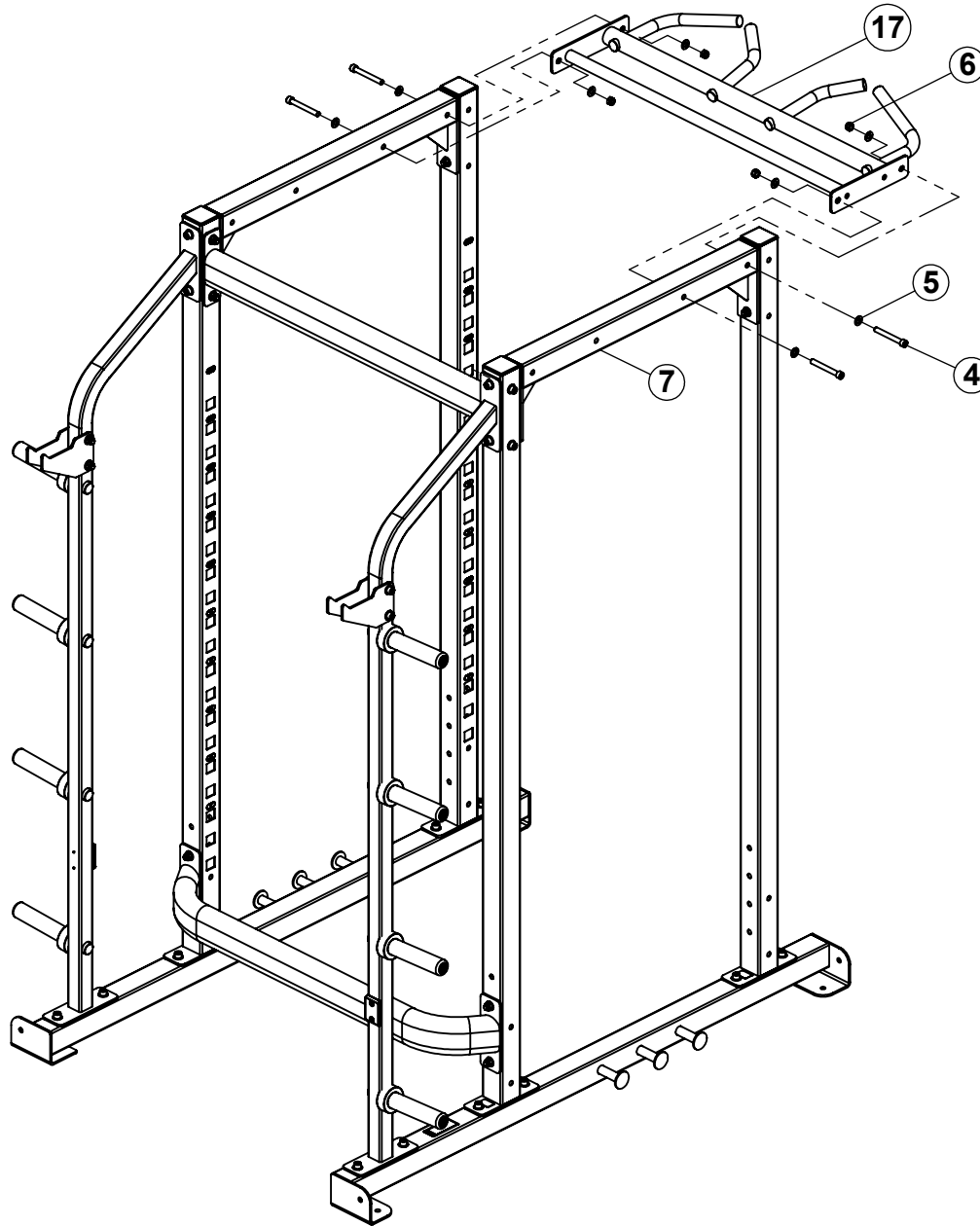

NOTE:

SECURELY tighten all the bolt connections in this step and previous steps.

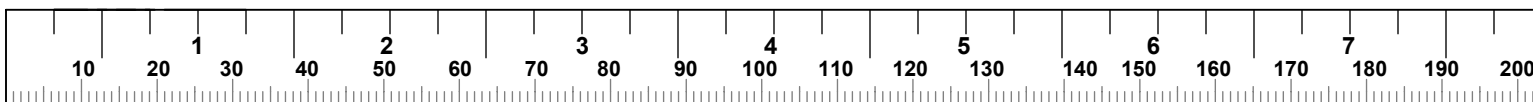

STEP 10

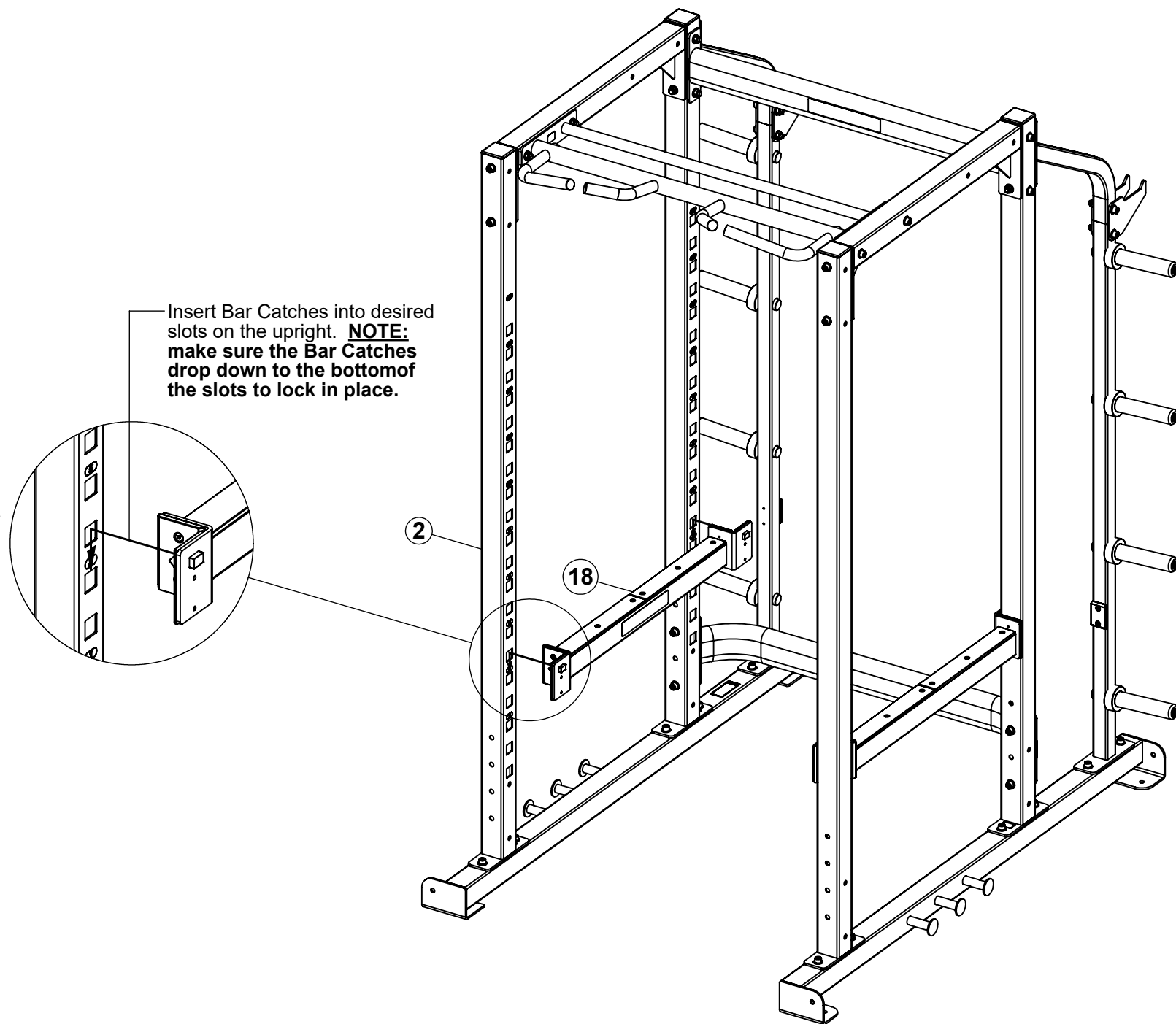

STEP 11

Insert Bar Supports into desired slots on the upright and allow it to drop down to lock in place.

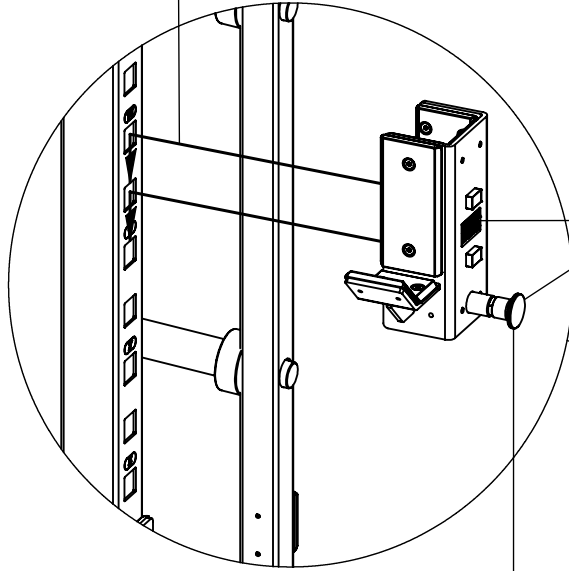

!WARNING
SPRING PIN
MUST BE FULLY
ENGAGED

To remove Bar Supports from upright, pull spring pin out to unlock, lift up and pull out.

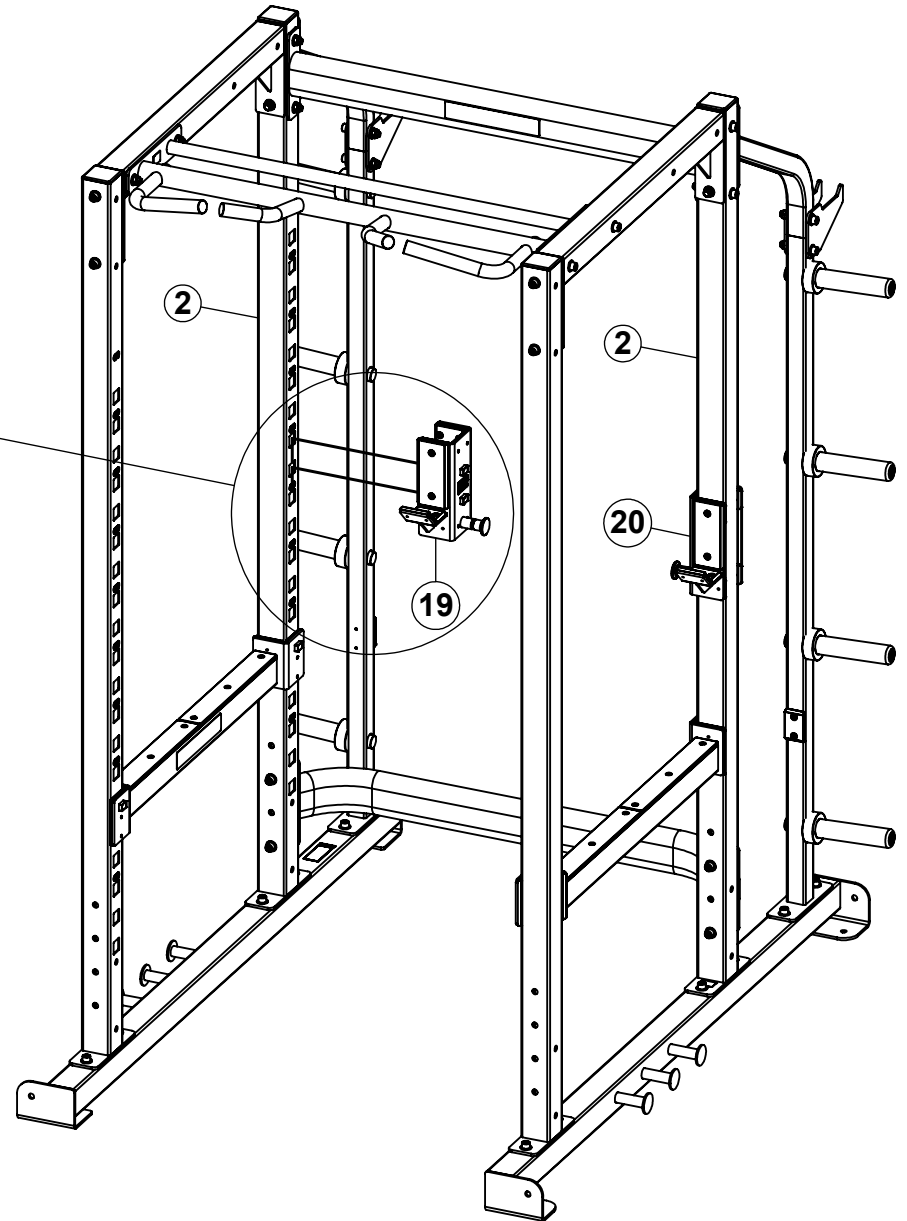

STEP 12a: XTHPHK TRIPLE POWER CAGE HARDWARE KIT

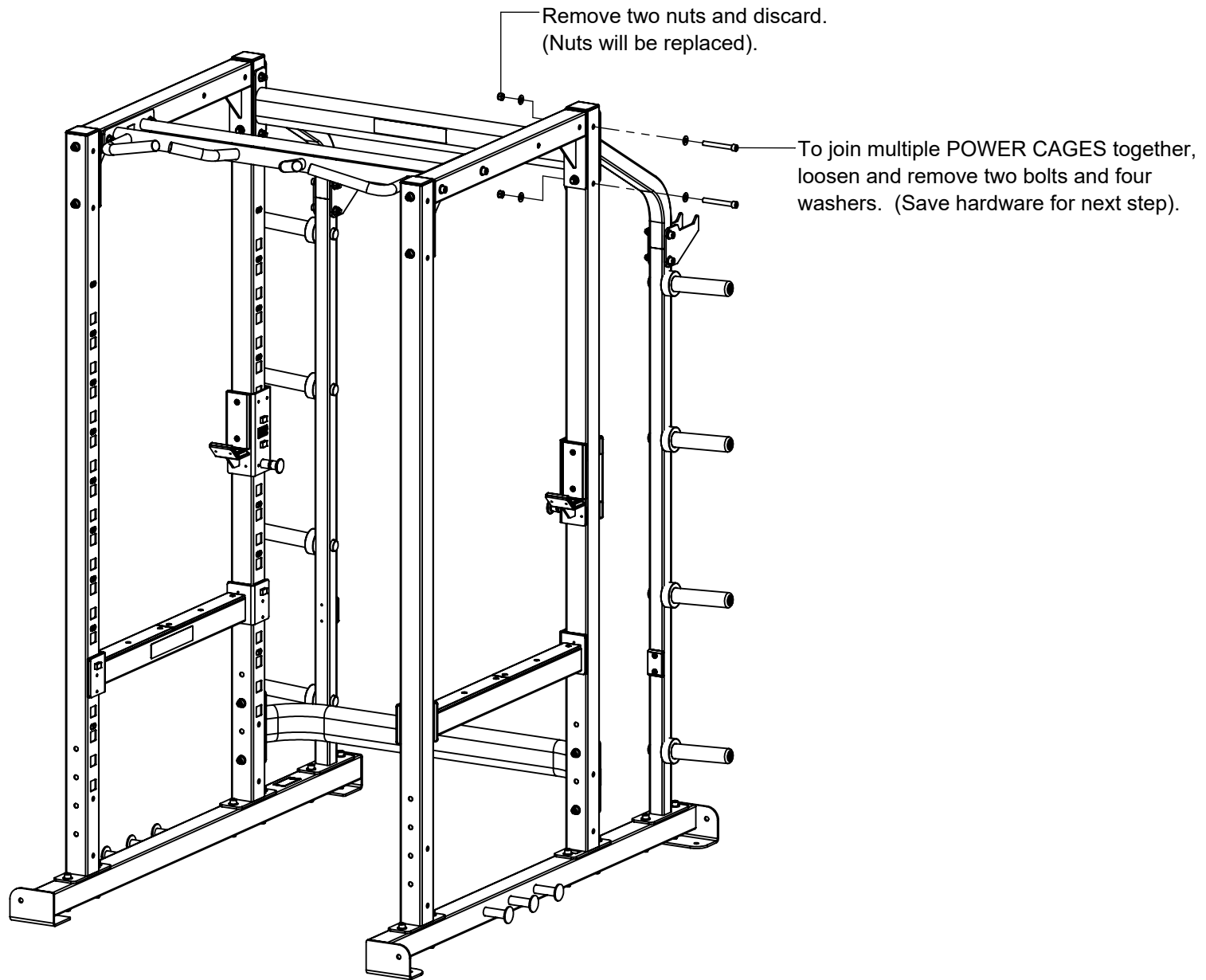

STEP 12b: XTHPHK TRIPLE POWER CAGE HARDWARE KIT.

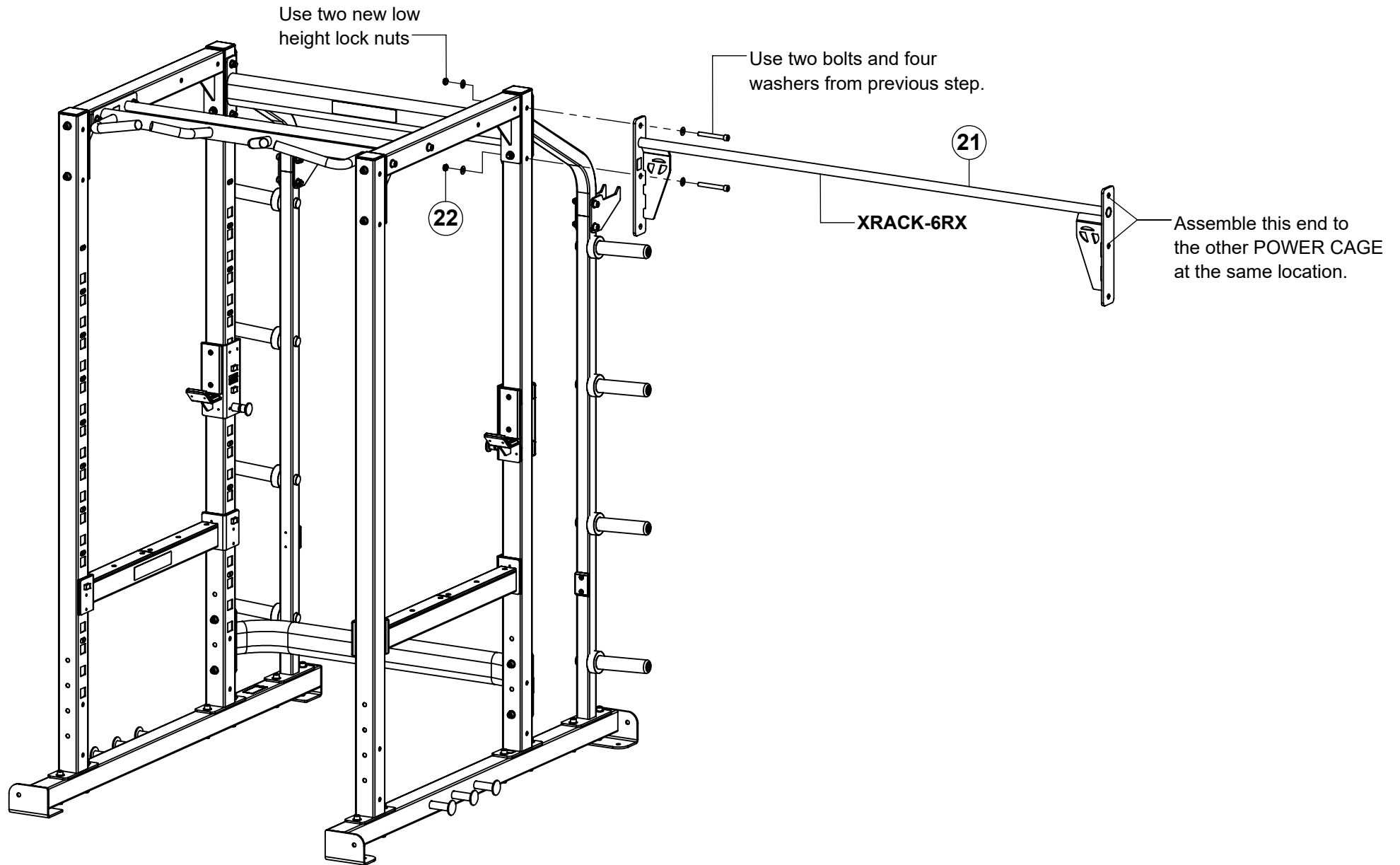

NOTE:

Assemble XRACK-6SX between POWER CAGES as shown.

STEP 13a: OPTIONAL XERT TO POWER CAGE SIDE

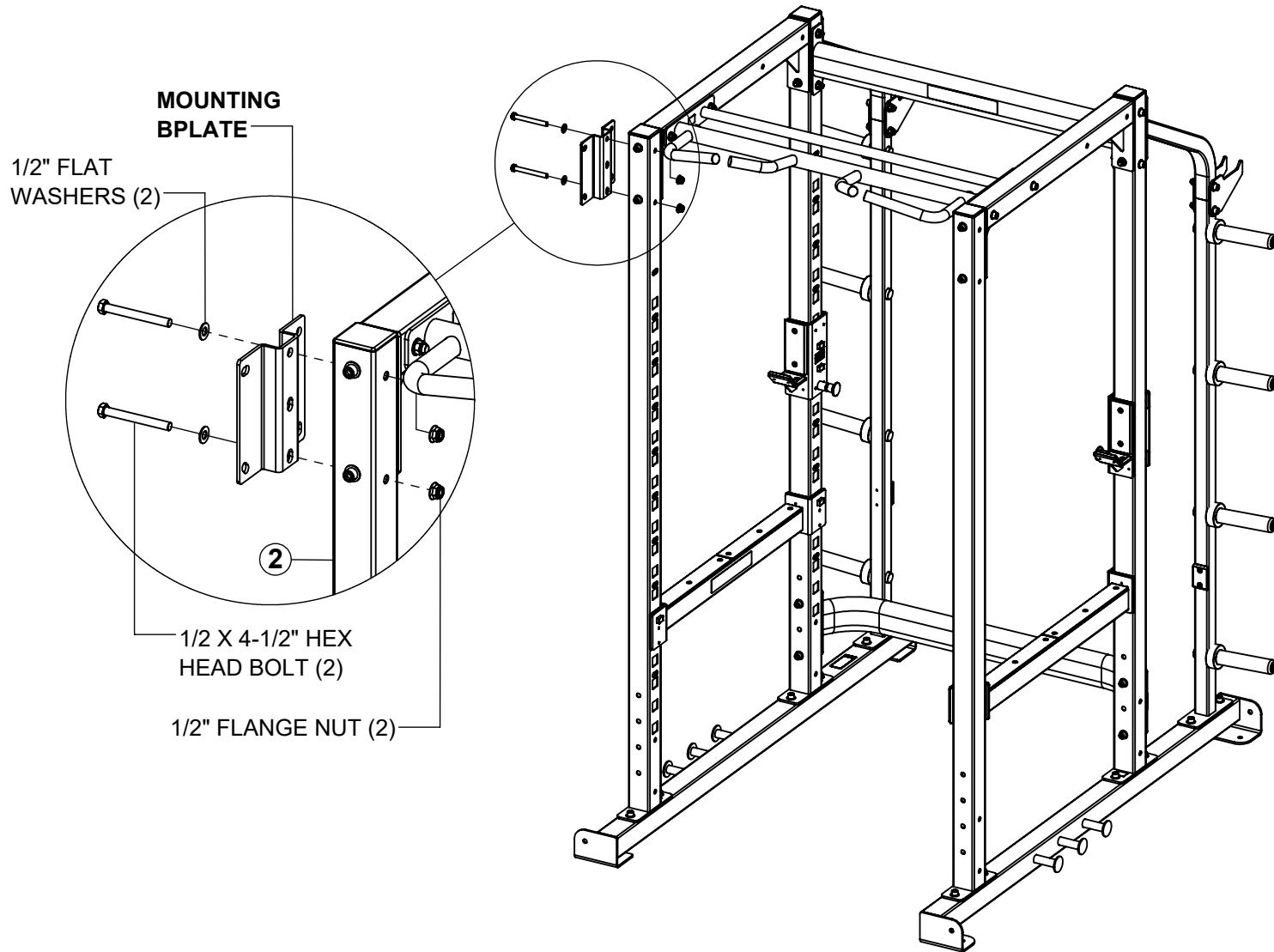

NOTE:

SECURELY assemble bolt connections in this step.

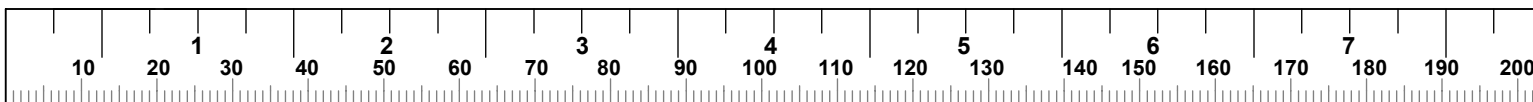

STEP 13b: OPTIONAL XERT TO POWER CAGE SIDE

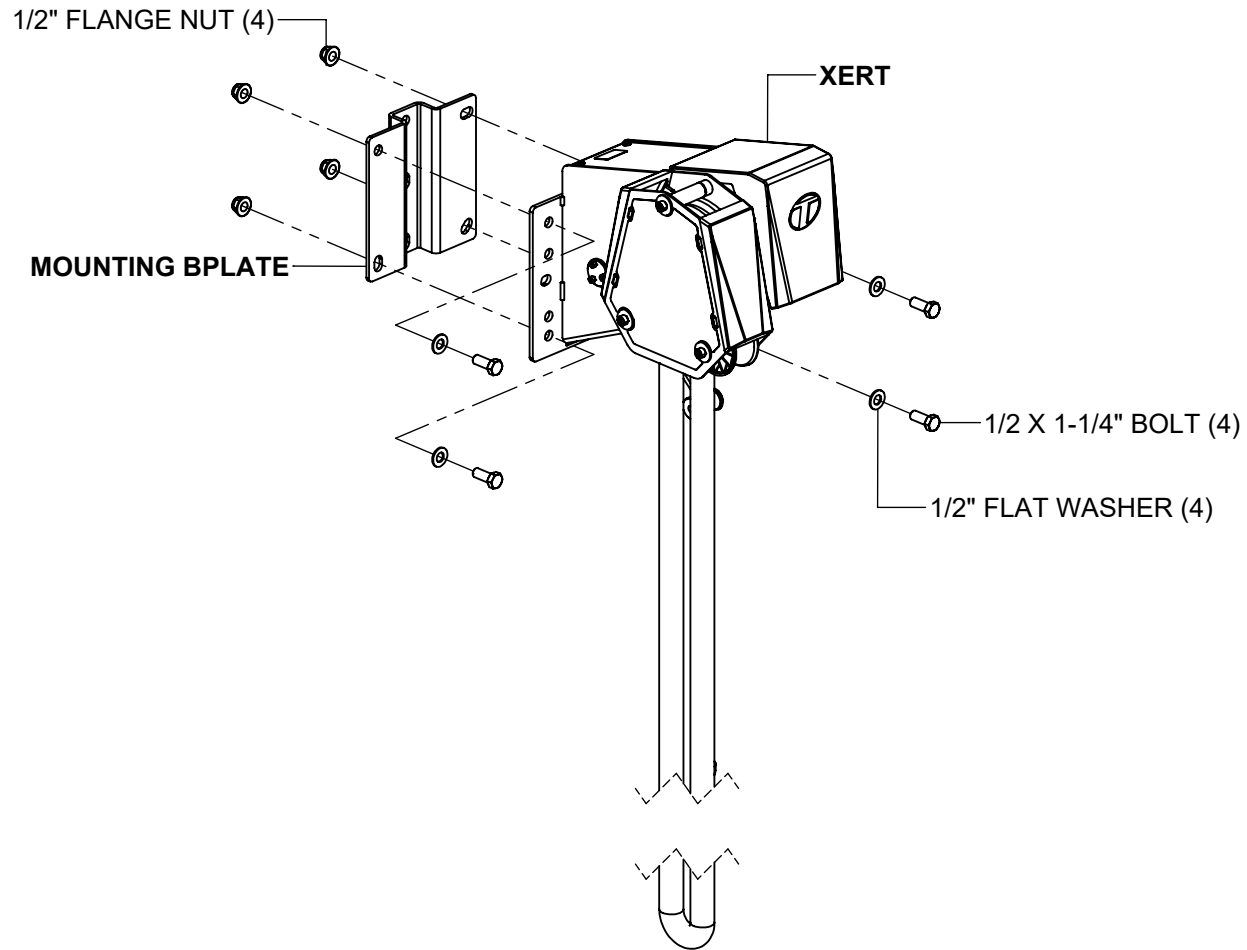

NOTE:

POWER CAGE has been hidden for assembly clarity.

SECURELY assemble bolt connections in this step.

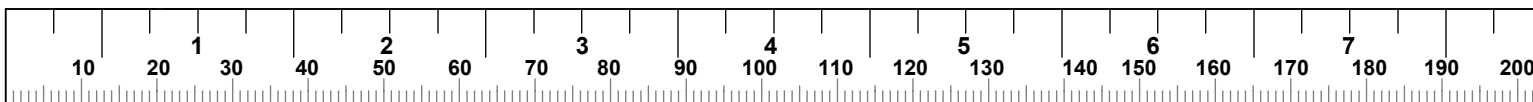

STEP 14a: OPTIONAL XERT TO POWER CAGE FRONT

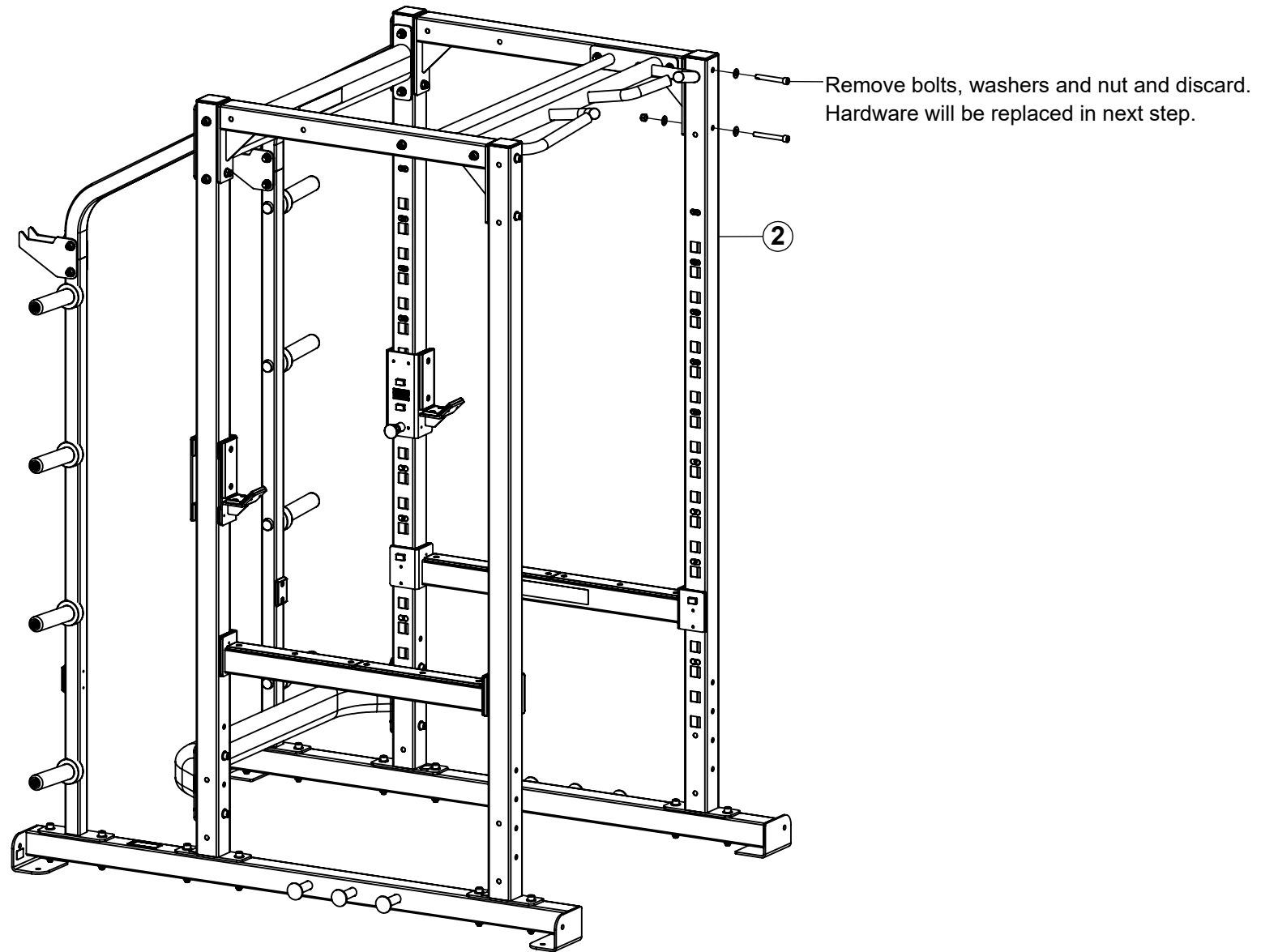

STEP 14b: OPTIONAL XERT TO POWER CAGE FRONT

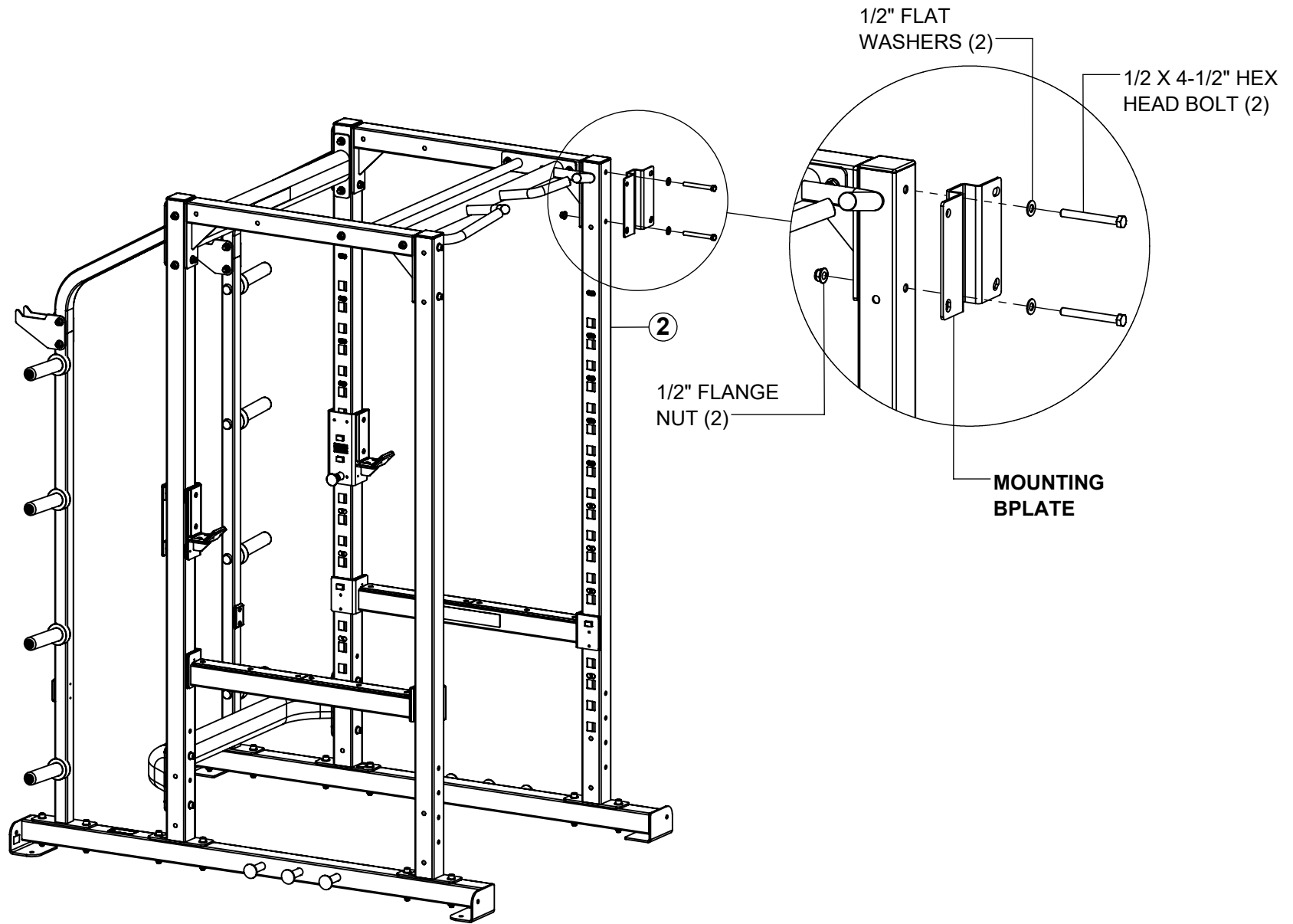

NOTE:

SECURELY assemble bolt connections in this step.

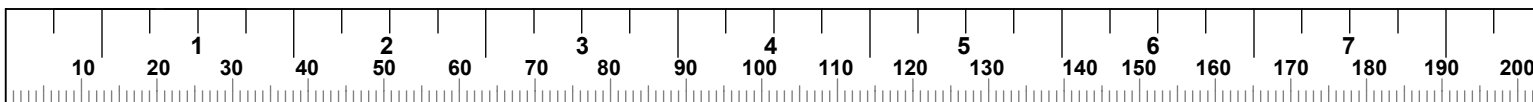

STEP 14c: OPTIONAL XERT TO POWER CAGE FRONT

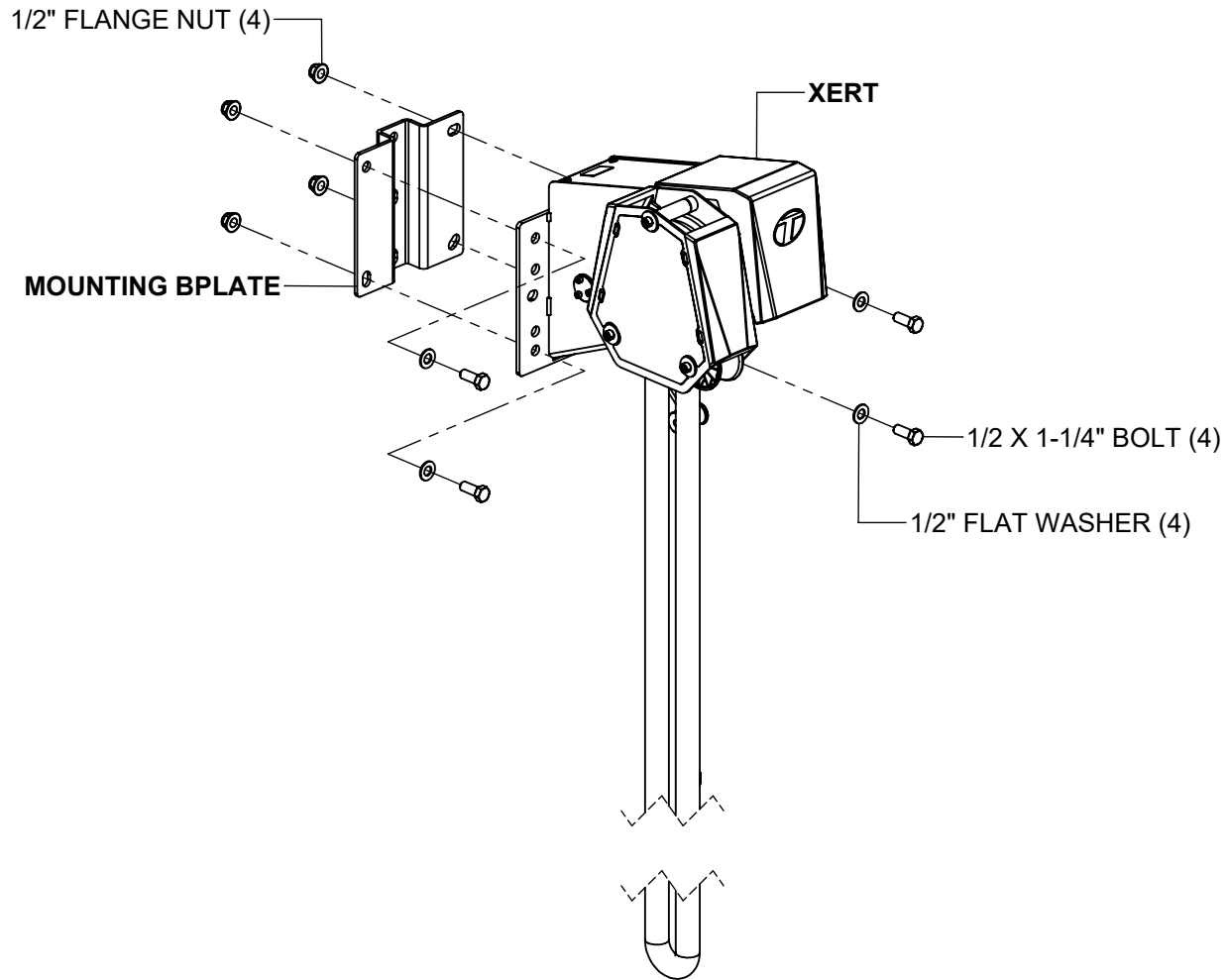

NOTE:

POWER CAGE has been hidden for assembly clarity.

SECURELY assemble bolt connections in this step.

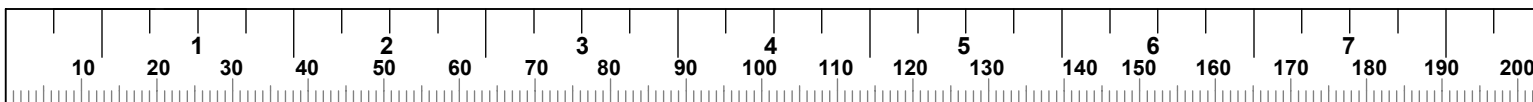

STEP 15

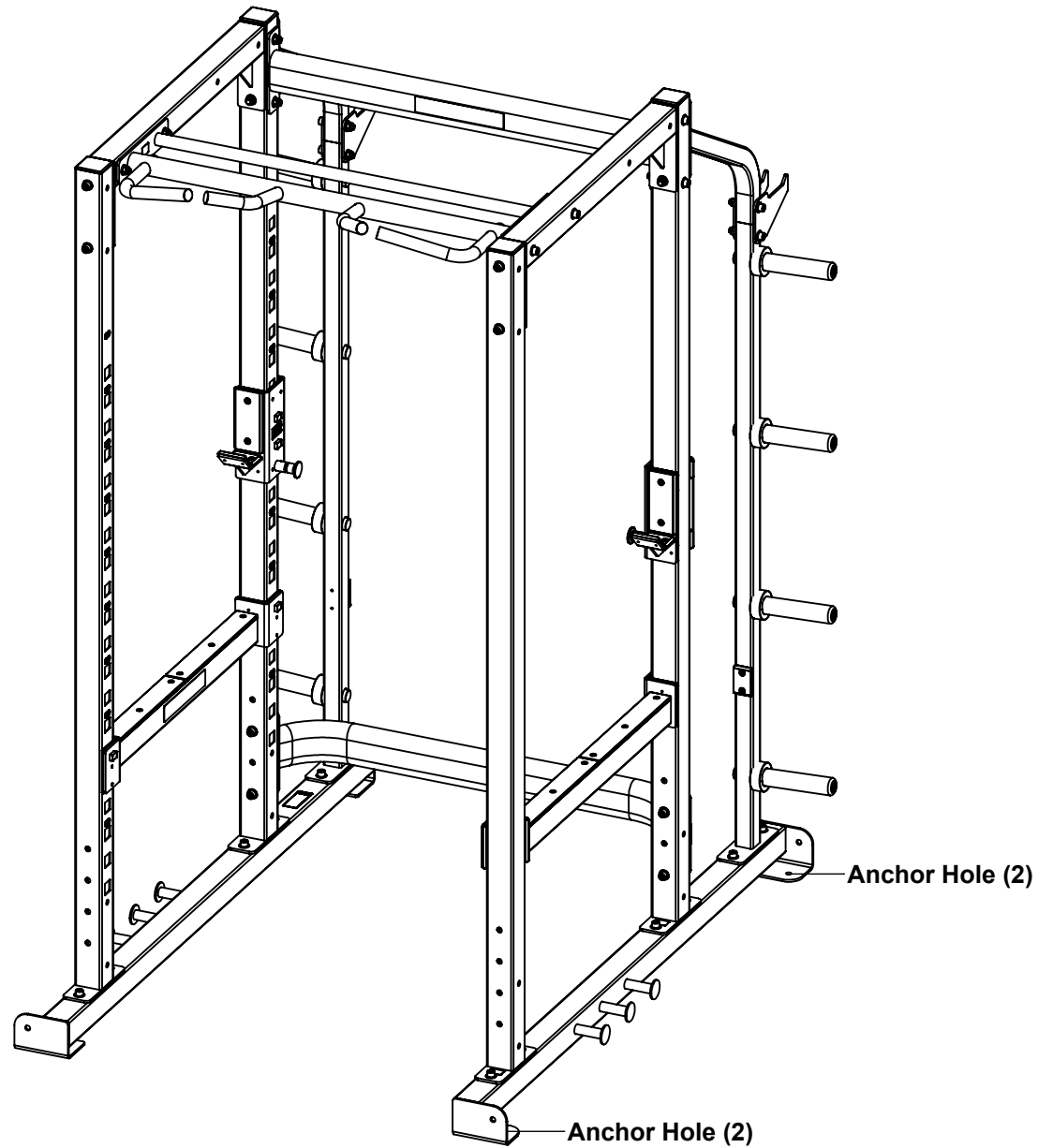

NOTES:

SECURELY anchor the machine to the floor using the anchor holes provided.

Consult a professional contractor for the actual anchoring of the machine.