

# XCREATE WALL SPACE ASSEMBLY GUIDE

VERSION: XCWS

PART #: 5843901-C

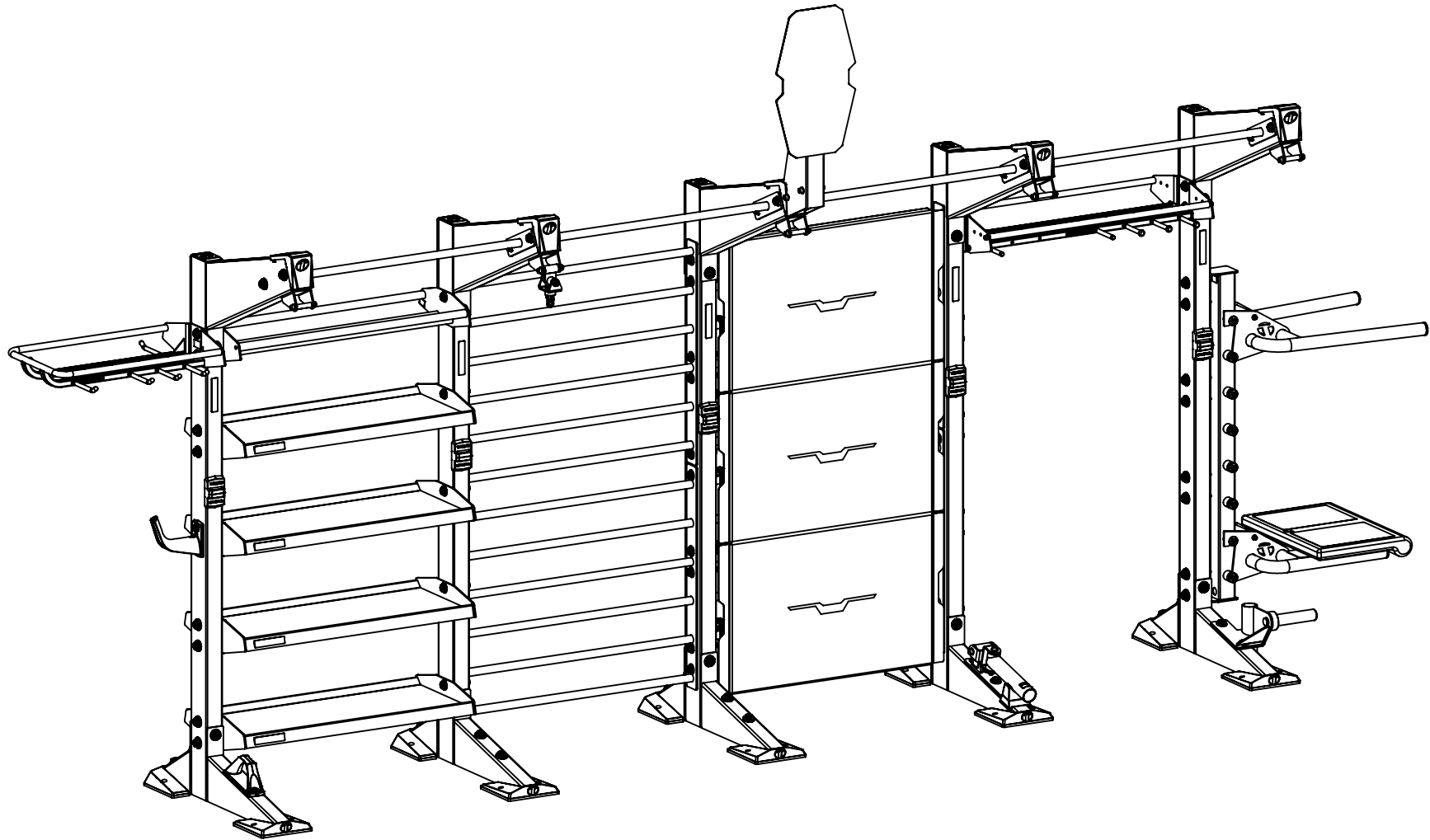

**TORQUE** USA

## TABLE OF CONTENTS

1. OVERVIEW AND TOOLS REQUIRED: **PAGE 3**
2. UPRIGHT ASSEMBLY: **PAGES 4-5**
3. HARDWARE COVER FINISH KIT: **PAGE 6**
4. ONE MODULE ASSEMBLY: **PAGE 7**
5. CABLE MODULES AND SMITH MODULE: **PAGE 10**
6. MODULE ASSEMBLY
  - 8' UPRIGHT MODULE EXTENSION: **PAGES 11-12**
  - 4'/6' ACCESSORY STORAGE MODULE: **PAGES 13-14**
  - 4'/6' UNIVERSAL BALL & HANGING STORAGE MODULE: **PAGES 15-16**
  - 4' STALL BAR MODULE: **PAGES 17-18**
  - 4' BALL TARGET WALL MODULE: **PAGES 19-21**
  - 8' OLYMPIC LIFTING STATION MODULE: **PAGES 22-26**
  - 4' ACCESSORY & BUMPER BOOKSHELF STORAGE MODULE: **PAGES 27-28**
  - 4' TANK DOCKING MODULE: **PAGES 29-32**
  - 4' X 5 BARBELL STORAGE MODULE: **PAGES 33-36**
  - 4' X 10 BARBELL STORAGE MODULE: **PAGES 37-40**
  - 4' 2 SIDED X 10 BARBELL STORAGE MODULE: **PAGES 41-44**
  - 4' 2 SIDED X 20 BARBELL STORAGE MODULE: **PAGES 45-48**
  - 4' MONITOR MOUNT & STORAGE MODULE: **PAGES 49-52**
  - 4' CUSTOM SIGN AND HANGING STORAGE: **PAGES 53-54**
  - ACCESSORY PEGS & MAT STORAGE PINS: **PAGE 55**
  - ACCESSORY TRAY LABELS: **PAGES 56**
7. ATTACHMENT ASSEMBLY
  - BALL & HANGING STORAGE EXTENSION: **PAGE 61**
  - BATTLE ROPE ANCHOR: **PAGE 62**
  - HANGING STORAGE HOOK: **PAGE 63**
  - DOUBLE PLAY: **PAGE 64**
  - HORIZONTAL MOUNT GROUND ROTATIONAL TRAINER: **PAGE 65**
  - 3-DIMENSIONAL SWIVEL: **PAGES 66-67**
  - BALL TARGET: **PAGES 68-70**
  - RESISTANCE BAND ANCHOR: **PAGE 71**
  - VERTICAL DUMBBELL RACK: **PAGE 72**
  - 4' MULTI GRIP CROSS: **PAGE 73**
  - 4' SINGLE SIDE HORIZONTAL WEIGHT STORAGE: **PAGE 76**
  - TOP BOOM EXTENSION: **PAGES 75-78**
  - ATTACHMENT ANCHOR: **PAGE 79**
  - DIP ATTACHMENT: **PAGE 80**
  - PLYO STEP: **PAGE 81**
  - ATTACHMENT EXTENSION: **PAGES 82-83**
6. ATTACHMENT ASSEMBLY CONTINUED
  - ATTACHMENT EXTENSION & 3 DIMENSIONAL SWIVEL W/MOUNT: **PAGE 84**
  - RELENTLESS ROPE TRAINER (UPRIGHT): **PAGES 85-86**
  - BOOM MOUNT: **PAGES 87-88**
  - RELENTLESS ROPE TRAINER & BOOM MOUNT: **PAGES 89-90**
  - RELENTLESS RIPPER & BOOM MOUNT: **PAGES 89-90**
  - XCREATE SIDE ATTACHMENT MOUNT: **PAGE 91**
  - 4' WALL ANCHOR BRACKET: **PAGES 92-96**
  - 4' COUNTERWEIGHT SUPPORT: **PAGES 97-99**
  - 6' COUNTERWEIGHT SUPPORT: **PAGES 100-104**
  - OUTRIGGER: **PAGES 105-106**
  - BOSU STORAGE ATTACHMENT: **PAGE 107**
  - FOAM ROLLER STORAGE: **PAGES 108-109**
  - STALL BAR DIP ATTACHMENT: **PAGE 110**
  - BAR CATCH STORAGE ATTACHMENT: **PAGE 111-112**
  - SUSPENSION CLIP: **PAGE 113**
7. ANCHORING: **PAGE 114**
8. URETHANE BOOTS: **PAGE 115**

## **WARNING!**

**ALL X-CREATE ARE REQUIRED TO BE ANCHORED TO THE FLOOR TO PREVENT ROCKING OR TIPPING DURING USE.**

## OVERVIEW AND TOOLS REQUIRED

X-CREATE Wall Space Systems can be customized in countless ways. This manual provides instructions for assembling base units, module options and attachment options.

Not all modules or attachments are detailed in this assembly guide. For further instruction on these, reference the individual guide for the module being installed.

If you worked with Torque X-Team Design during the purchasing process, please request a Bill of Material Drawing to reference your exact set-up. For assistance, contact [www.sales@torquefitness.com](mailto:www.sales@torquefitness.com) or call (763) 754-7533

### **NOTE:**

When assembling any X-CREATE System that is longer than one module wide, the hardware will be shared between two side by side modules and pull-up bars. It is recommended to keep all bolt connections loose until the base system and all of the module stations have been assembled. Securely tighten all frame connections at this time, and then proceed to the attachment options. Attachment options can be securely tightened as they are assembled.

For the purpose of illustration, the 8U is shown in this assembly guide. The 7U can be assembled the exact same way where specified in the notes.

### **TOOLS FOR ASSEMBLY:**

- 3/8" ALLEN WRENCH
- 5/16" ALLEN WRENCH
- 3/16" ALLEN WRENCH
- 3/4" WRENCH OR SOCKET
- 9/16" WRENCH OR SOCKET
- 1/2" WRENCH OR SOCKET
- RUBBER MALLETT

## **WARNING!**

**ALL X-CREATE ARE REQUIRED TO BE ANCHORED TO THE FLOOR TO PREVENT ROCKING OR TIPPING DURING USE.**

# XCREATE-U-8SS ASSEMBLY

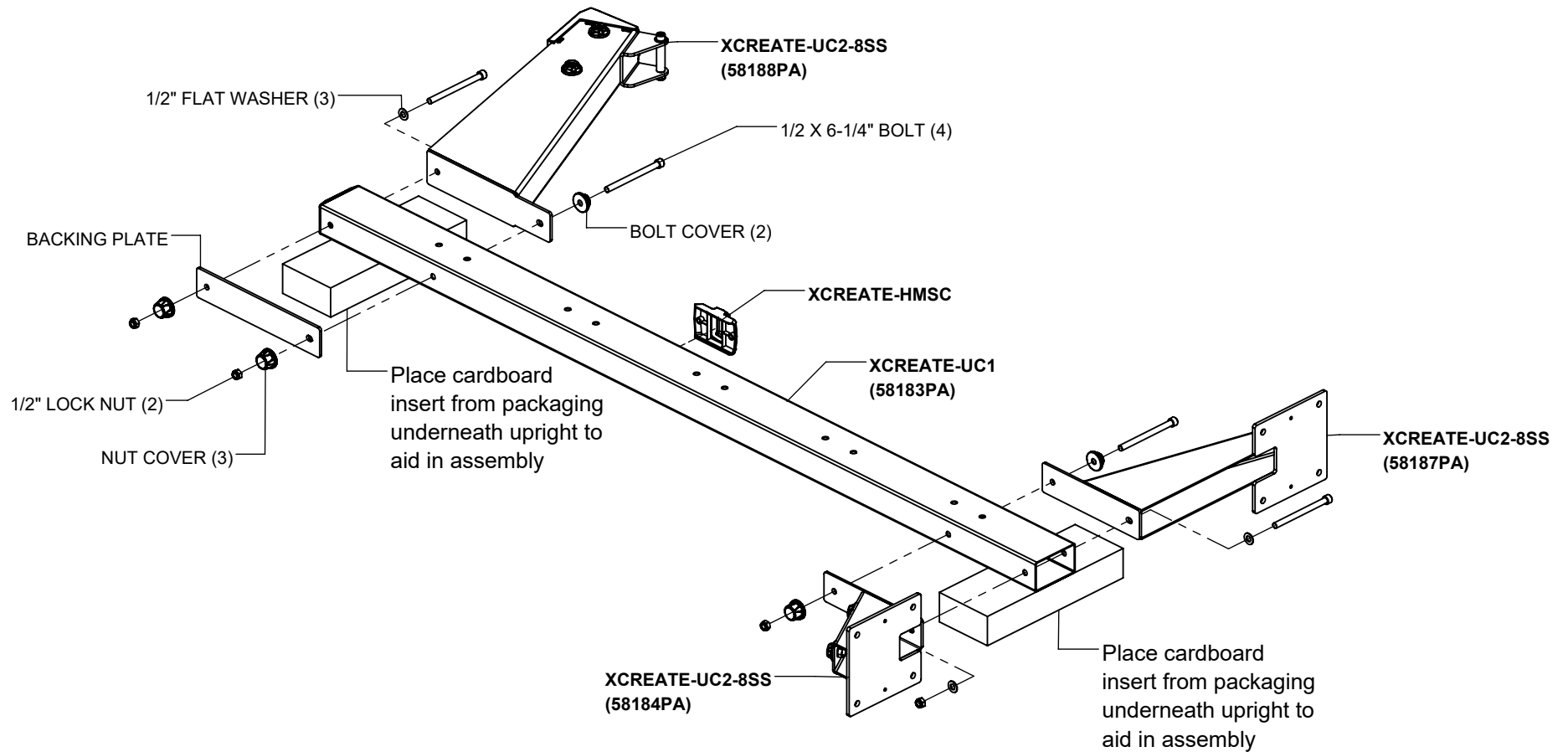

## NOTES:

This step requires two people to assemble. Please get help.

Assemble the UPRIGHT on the floor.

Assemble all parts together first, then **SECURELY** tighten all bolt connections.

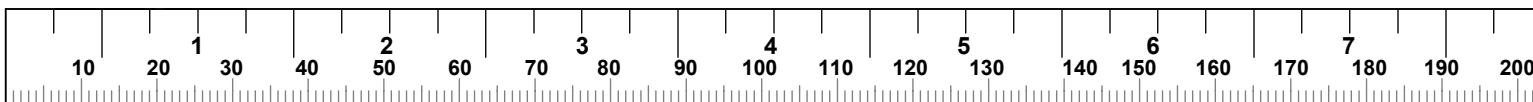



# XCREATE-U-7SS ASSEMBLY

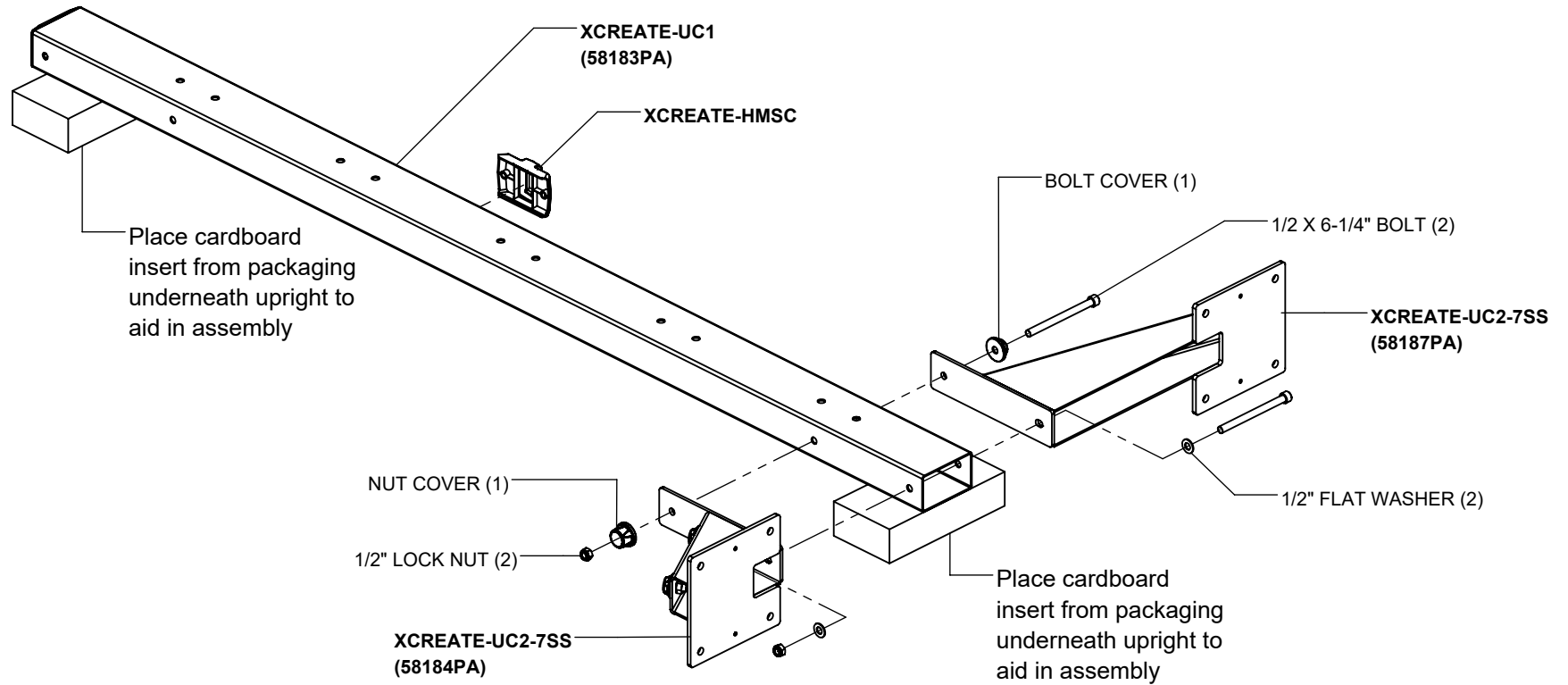

## NOTES:

This step requires two people to assemble. Please get help.

Assemble the UPRIGHT on the floor.

Assemble all parts together first, then **SECURELY** tighten all bolt connections.

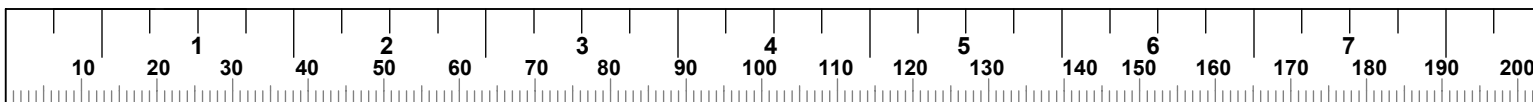

## HARDWARE COVERS

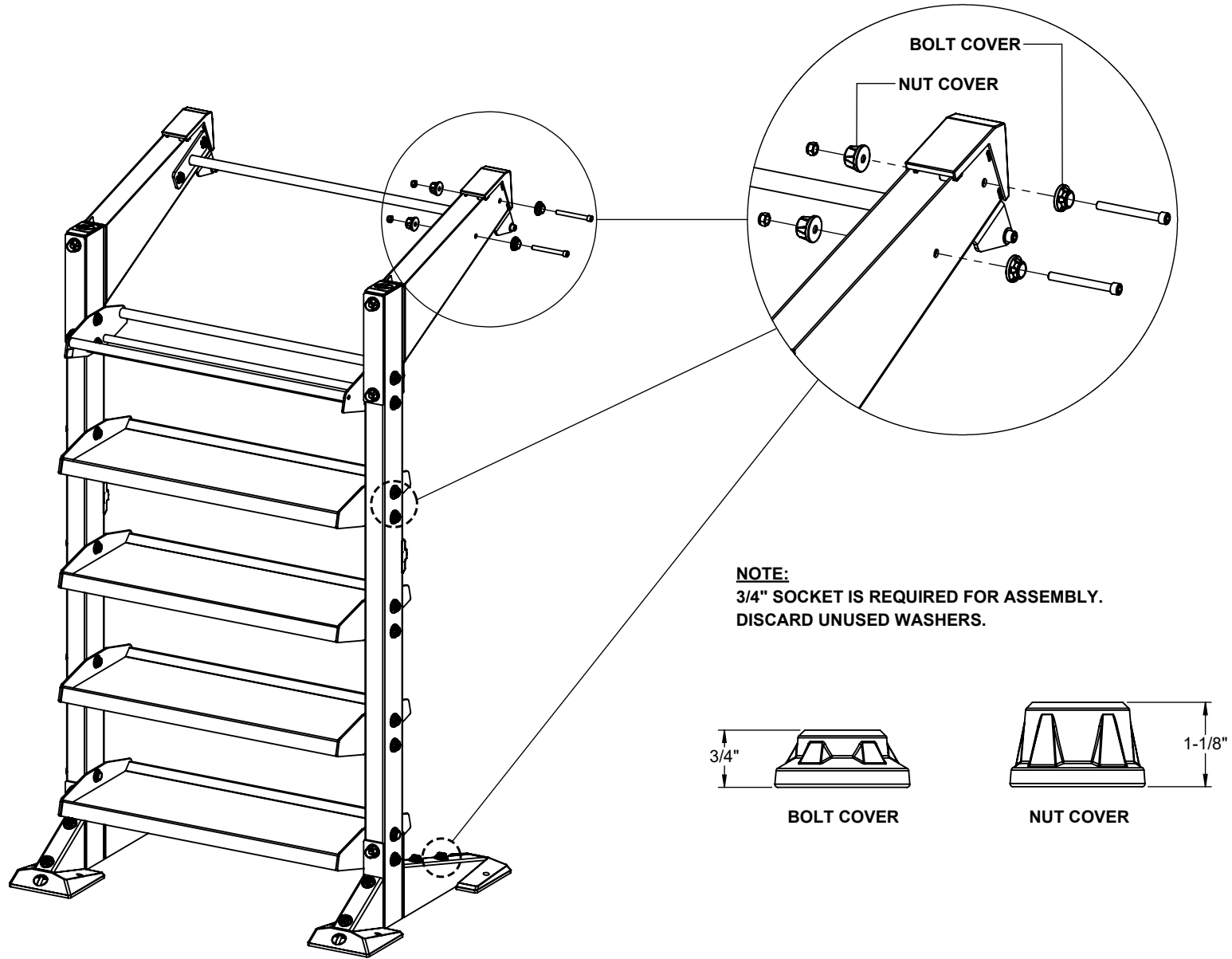

### **IMPORTANT NOTICE ABOUT HARDWARE COVERS:**

The bolt and nut covers **may not fit all assembly applications.**  
Use the flat washers included when shown in this guide.

# ONE MODULE ASSEMBLY

**NOTE:**

REMOVE END CAPS PRIOR TO ASSEMBLY.  
RE-ATTACH END CAPS AFTER ASSEMBLY (2)

**NOTE:**

MAKE SURE TO USE PRE-INSTALLED SPACERS (4)

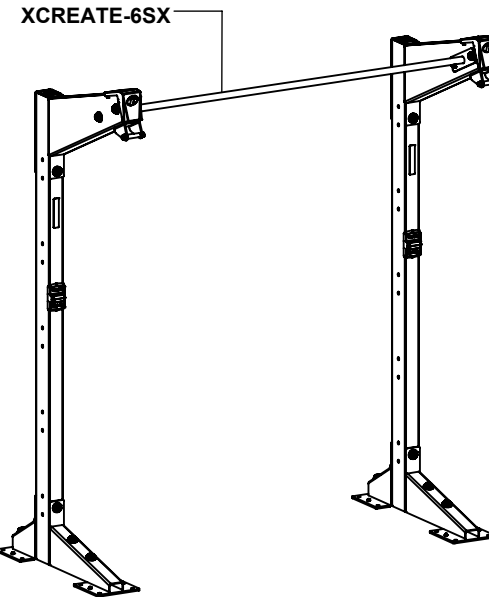
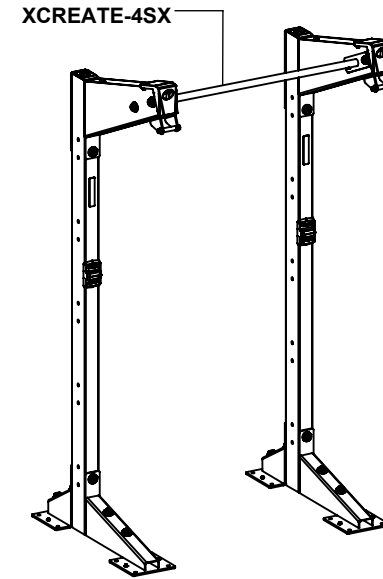
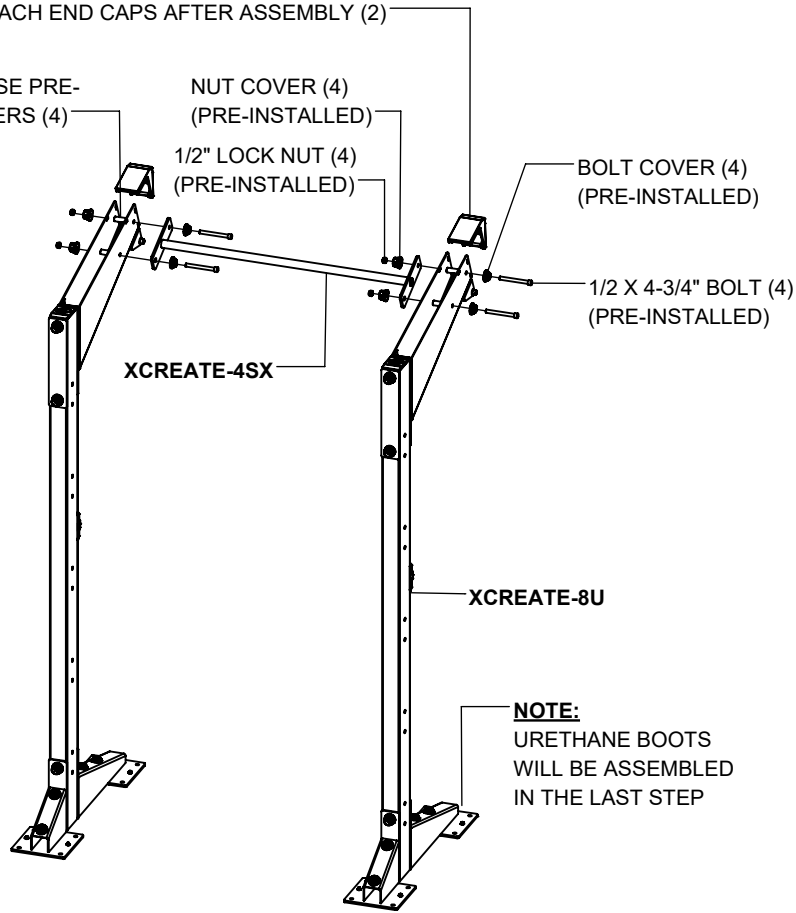

**NOTES:**

For the purpose of illustration the XCREATE-4SX is shown.  
The XCREATE-6SX is assembled the same way.

**LOOSELY** assemble bolt connections in this step.

If more than one module will be assemble, refer to **PAGE 7**.

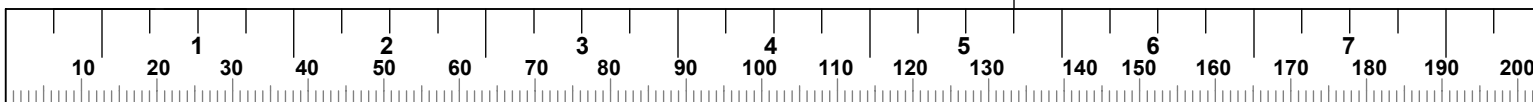

**MODULES**

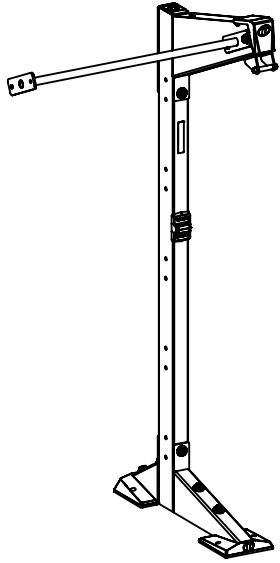

**8' UPRIGHT  
MODULE EXTENSION**

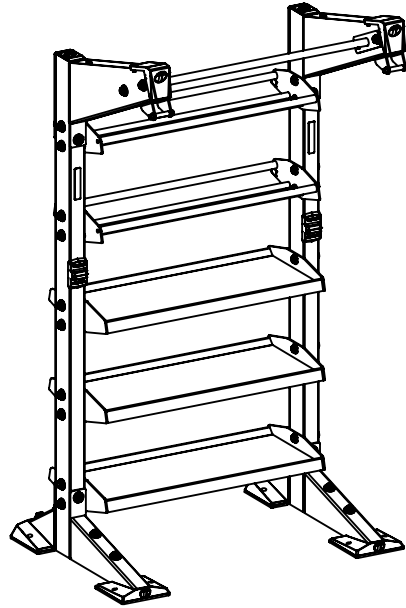

**4' / 6' STORAGE MODULE**

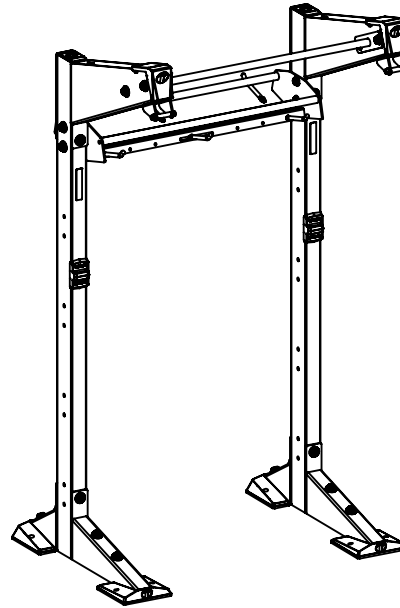

**4' / 6' BALL & HANGING  
STORAGE MODULE**

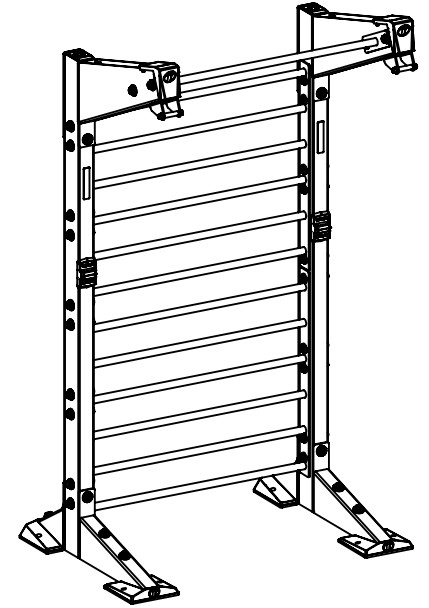

**4' STALL BAR MODULE**

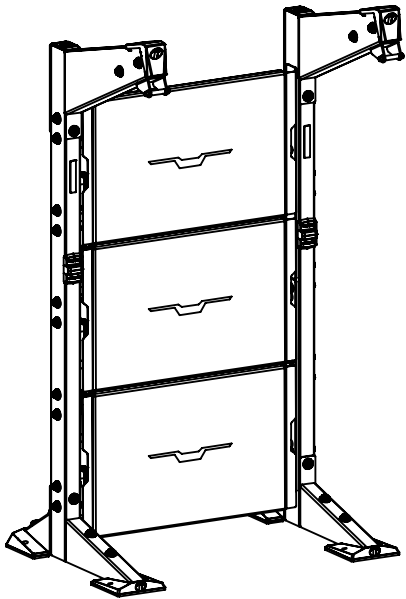

**4' BALL TARGET WALL PAD  
MODULE**

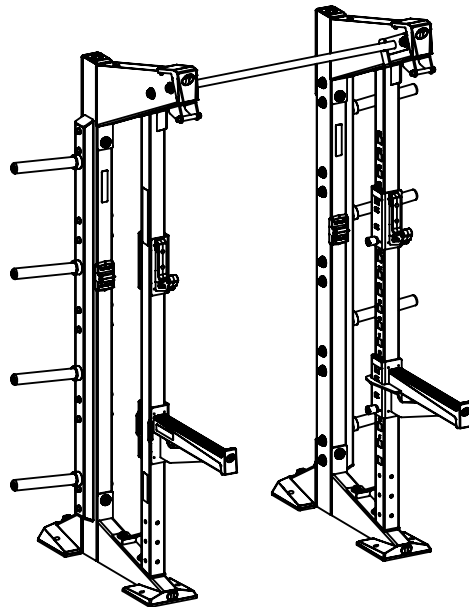

**8' OLYMPIC LIFTING  
STATION MODULE**

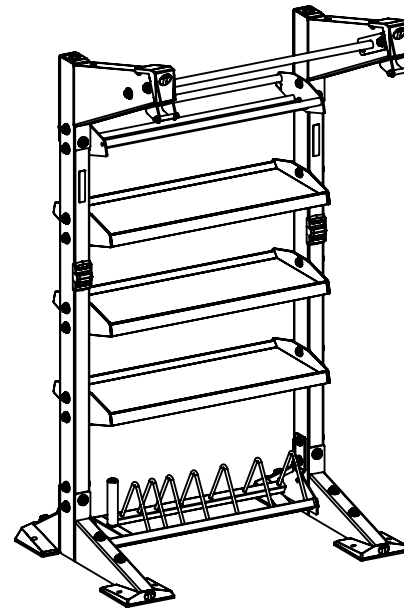

**4' / 6' ACCESSORY & BUMPER  
STORAGE MODULE**

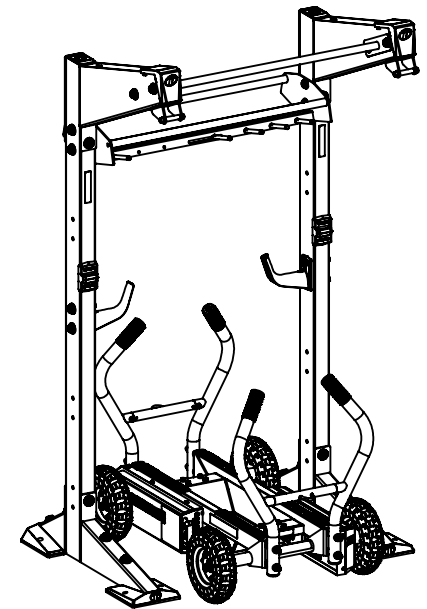

**4' TANK DOCKING MODULE**

**MODULES**

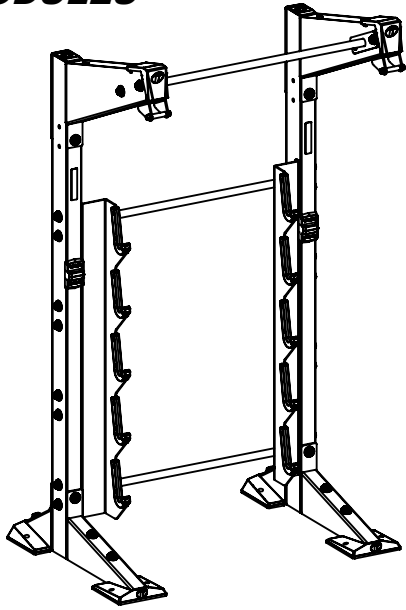

**4' X 5 BARBELL STORAGE  
MODULE**

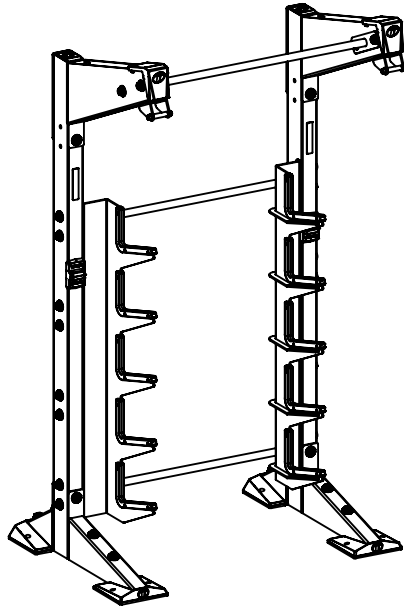

**4' X 10 BARBELL STORAGE  
MODULE**

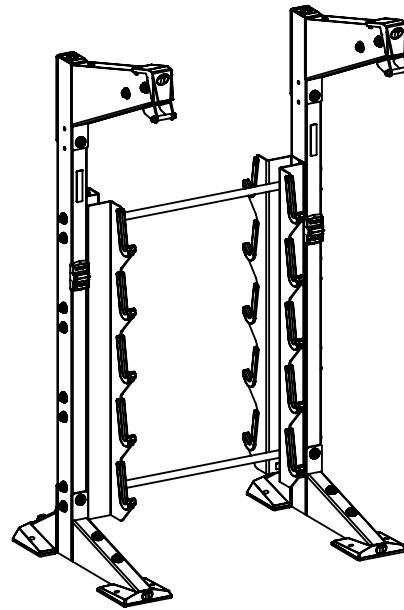

**4' X 2 SIDED X 10 BARBELL  
STORAGE MODULE**

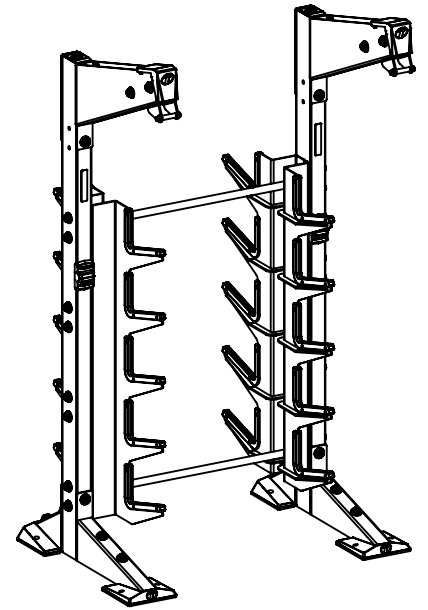

**4' X 2 SIDED X 20 BARBELL  
STORAGE MODULE**

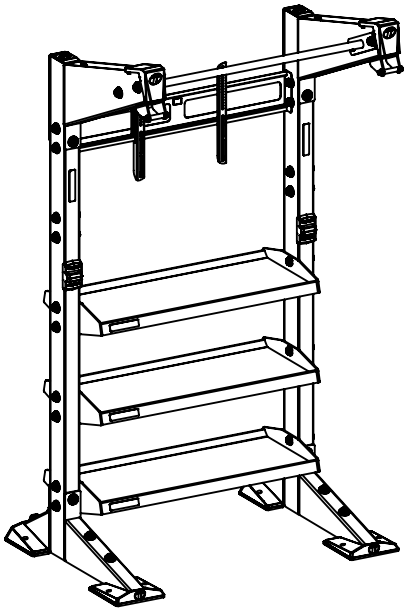

**4' MONITOR MOUNT  
STORAGE MODULE**

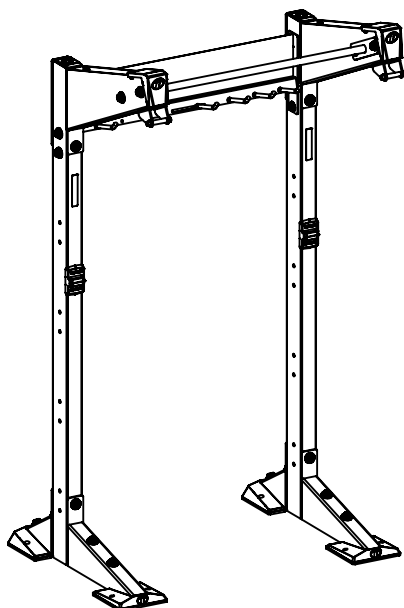

**4' CUSTOM SIGN AND HANGING  
STORAGE MODULE**

**MODULES NOT COVERED IN THIS GUIDE**

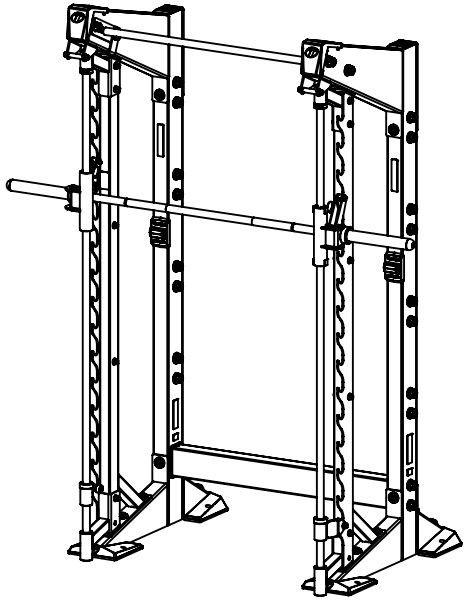

**SMITH MODULE**

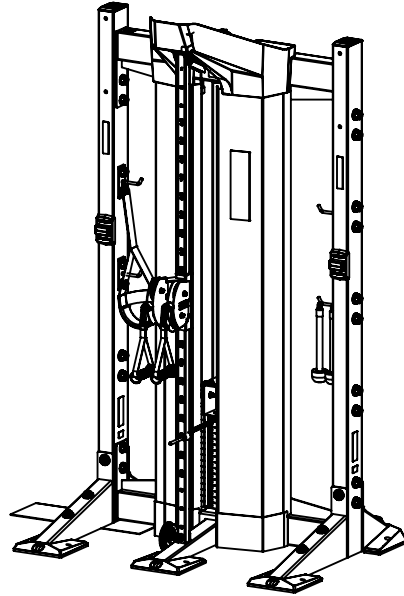

**CABLE COMPONENT  
MODULE**

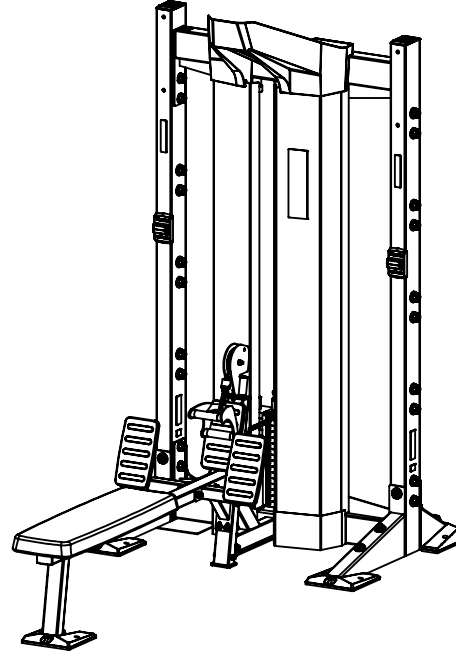

**SEATED ROW  
MODULE**

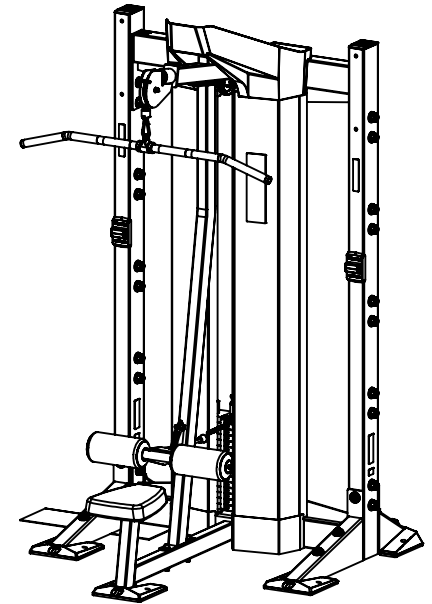

**LAT PULL DOWN  
MODULE**

**NOTES:**

For the above modules, visit [Torquefitness.com](https://torquefitness.com) for the specific assembly manual for the module being assembled. The manuals can be downloaded at <https://commercial.torquefitness.com/pages/assembly-manuals>

**8' UPRIGHT MODULE EXTENSION**

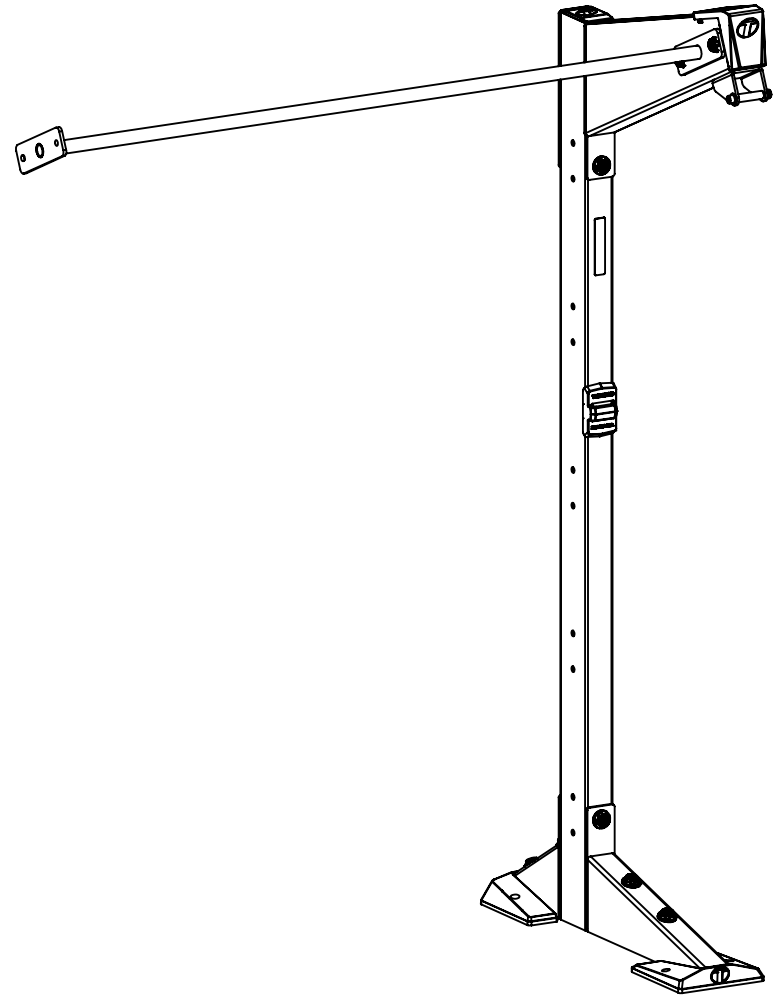
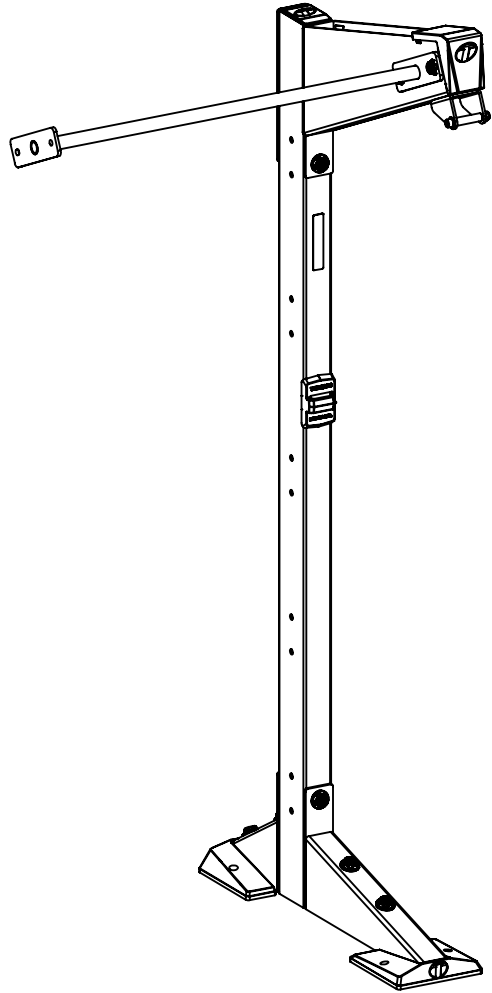

# 8' UPRIGHT MODULE EXTENSION

**NOTE:**  
MAKE SURE TO USE PRE-INSTALLED SPACERS (4)

**NOTE:**  
REMOVE END CAP PRIOR TO ASSEMBLY.  
RE-ATTACH END CAP AFTER ASSEMBLY (2)

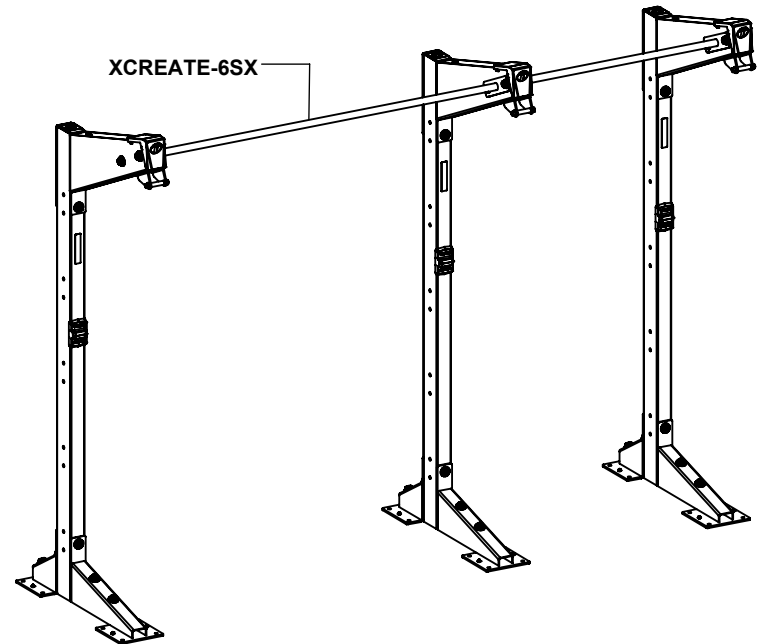
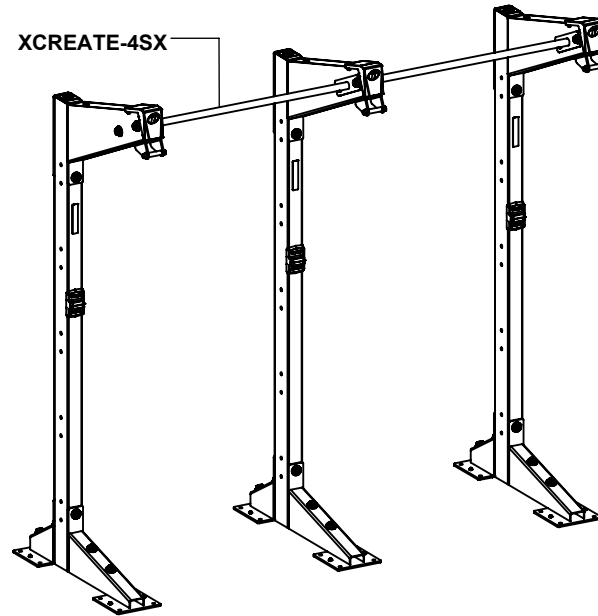
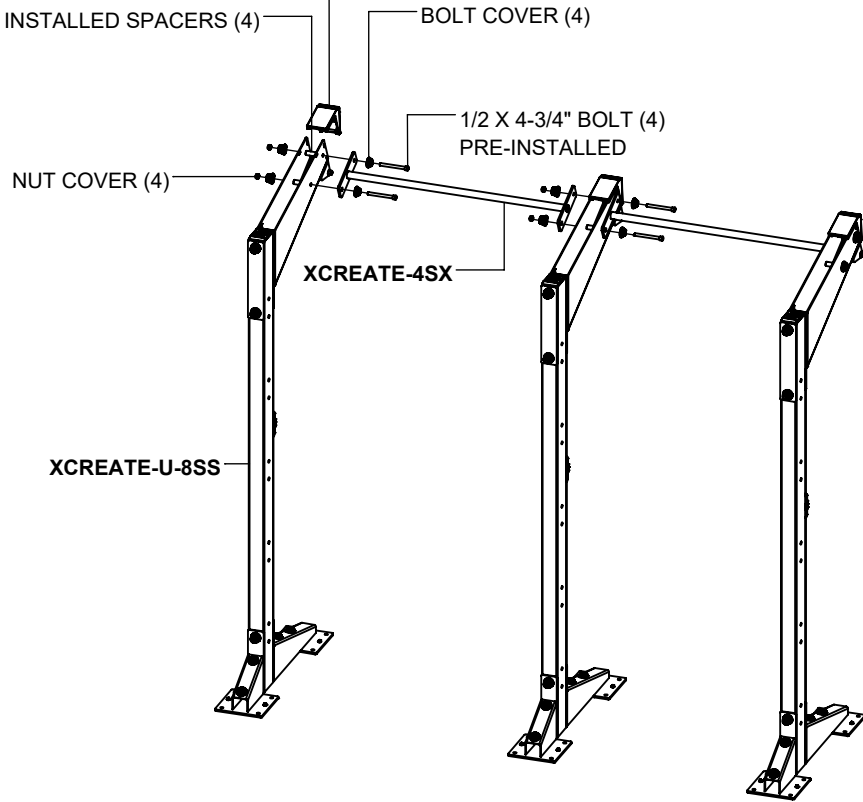

**NOTES:**

For the purpose of illustration the 4' module extension is shown. The 6' module extension is assembled the same way.

**LOOSELY** assemble bolt connections in this step.

Repeat this step for as many modules there are to assemble.

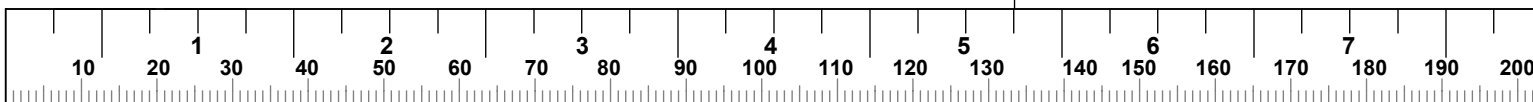



**4' / 6' STORAGE MODULE**

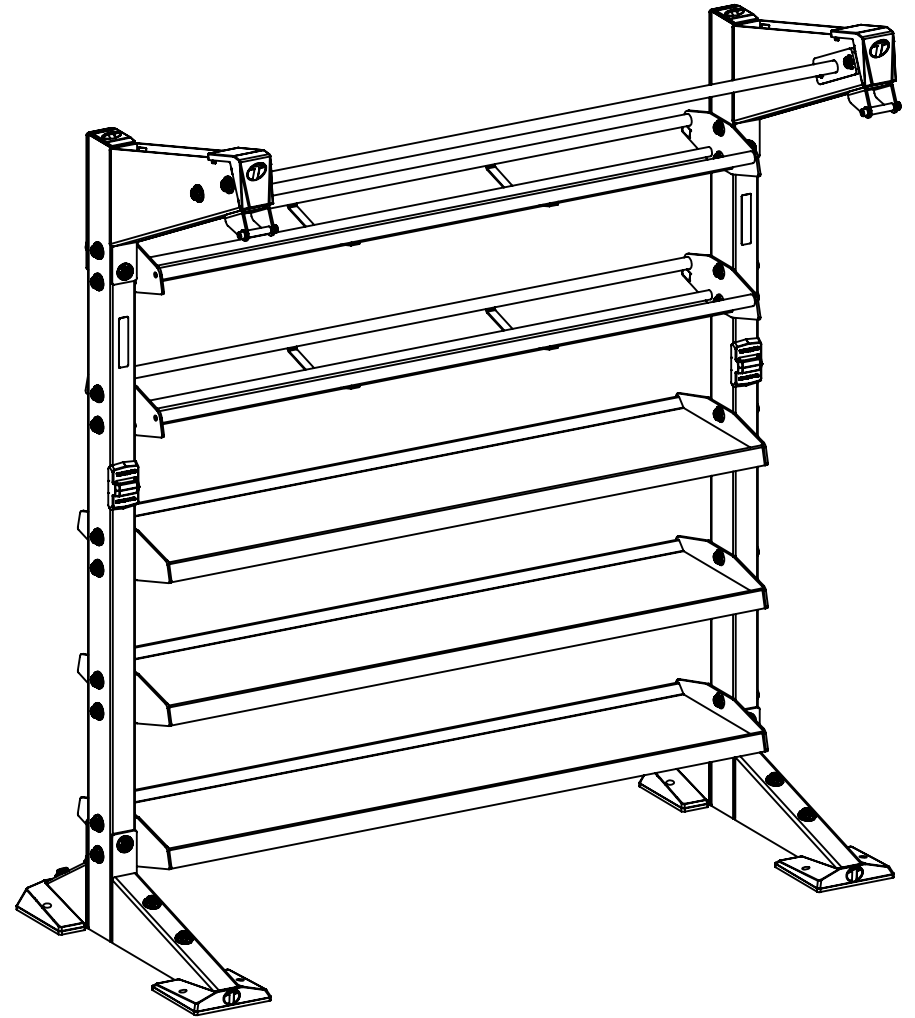
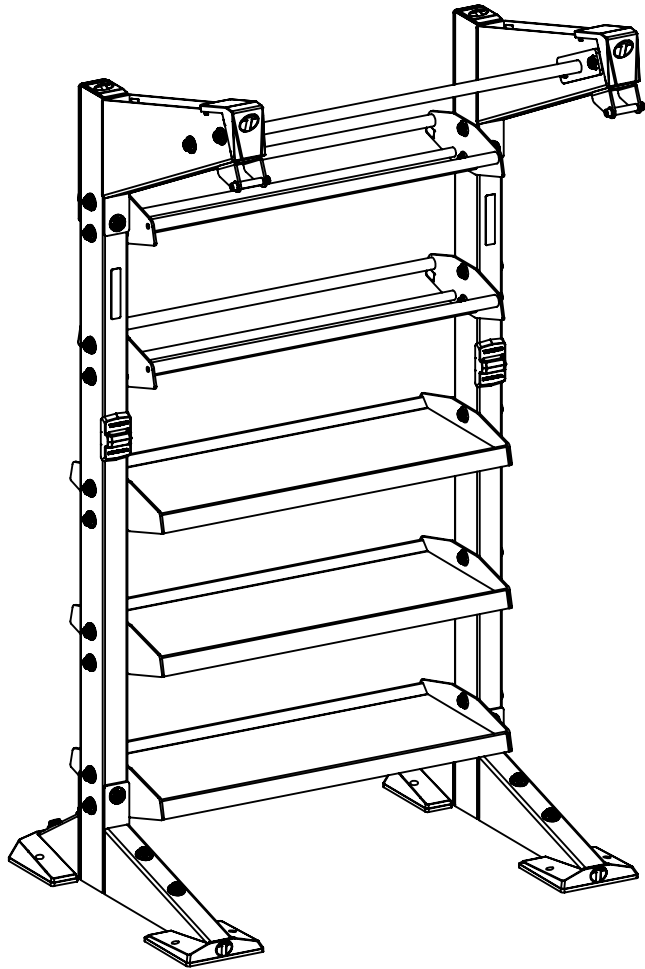

# 4' / 6' STORAGE MODULE

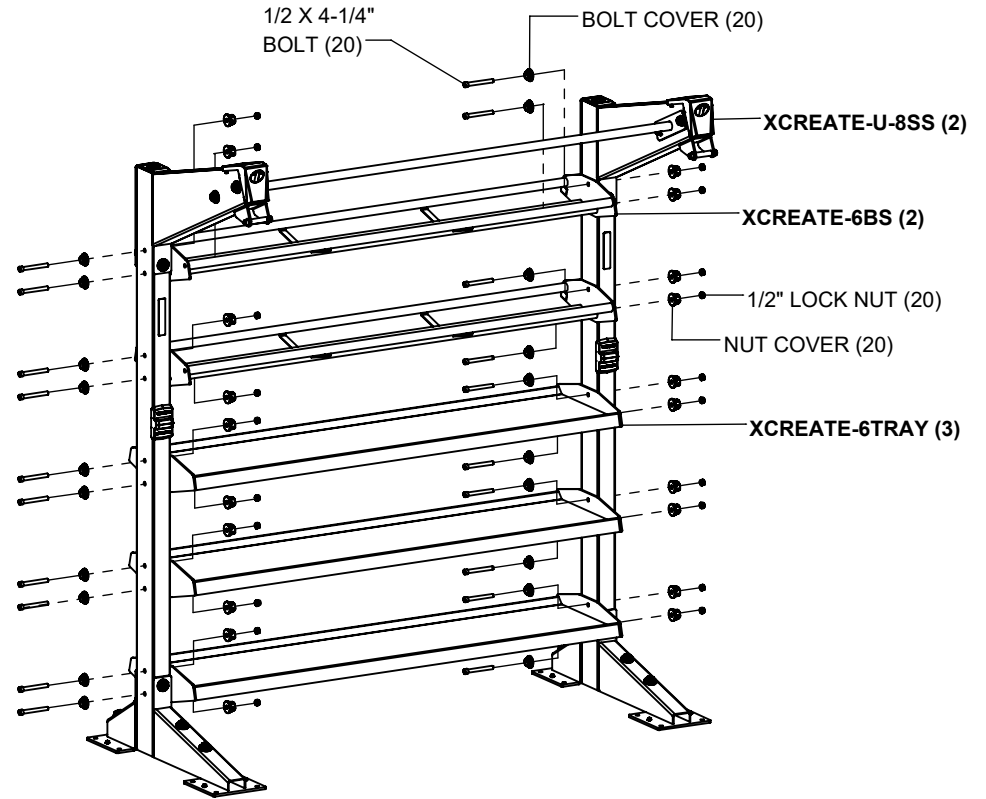
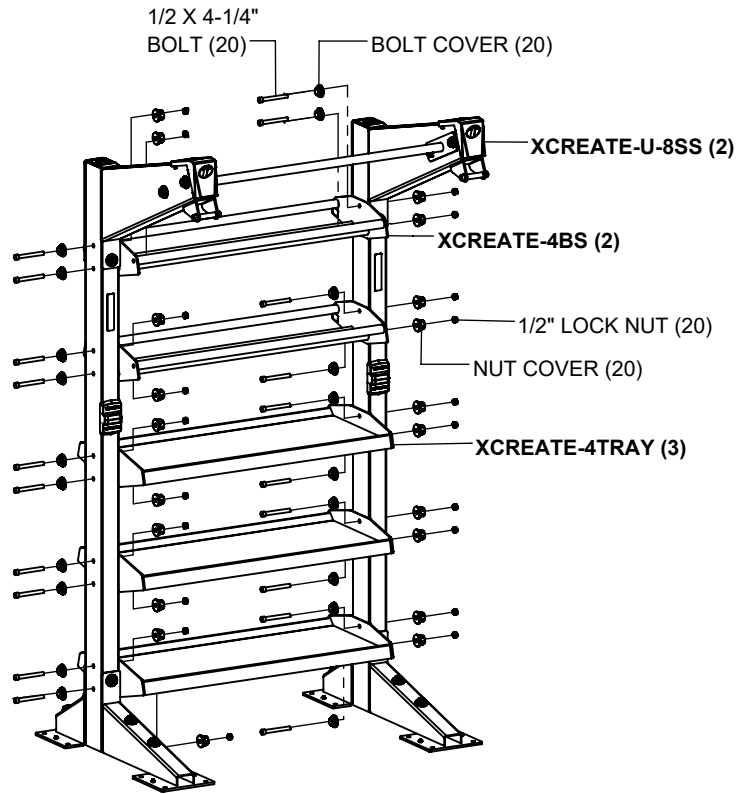

## NOTES:

If more modules will be assembled, do not tighten bolts at this time. If this is the only module being assembled, then **SECURELY** tighten all bolts in this step and previous steps.

The **XCREATE-U-7SS** is assembled the exact same way.

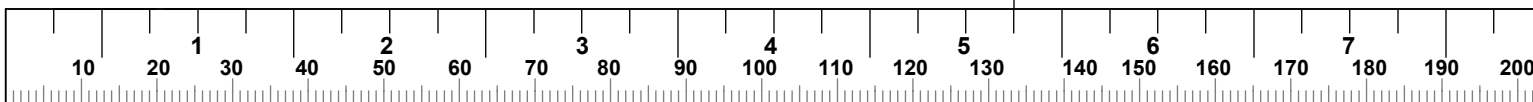

**4' / 6' UNIVERSAL BALL & HANGING  
STORAGE MODULE**

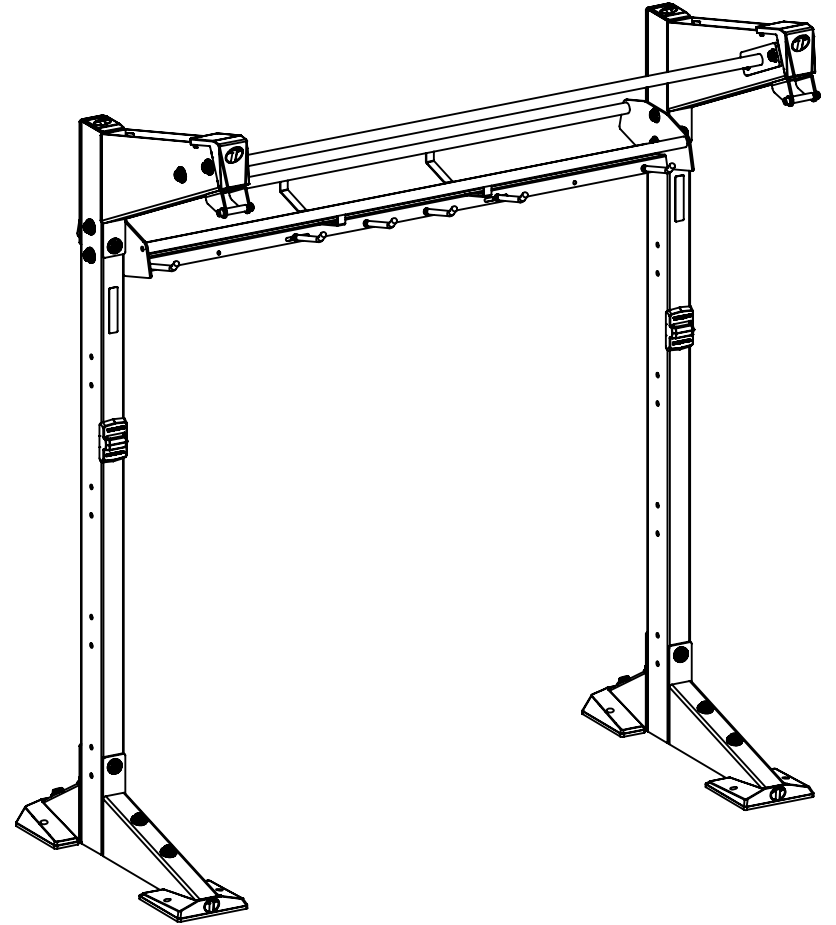
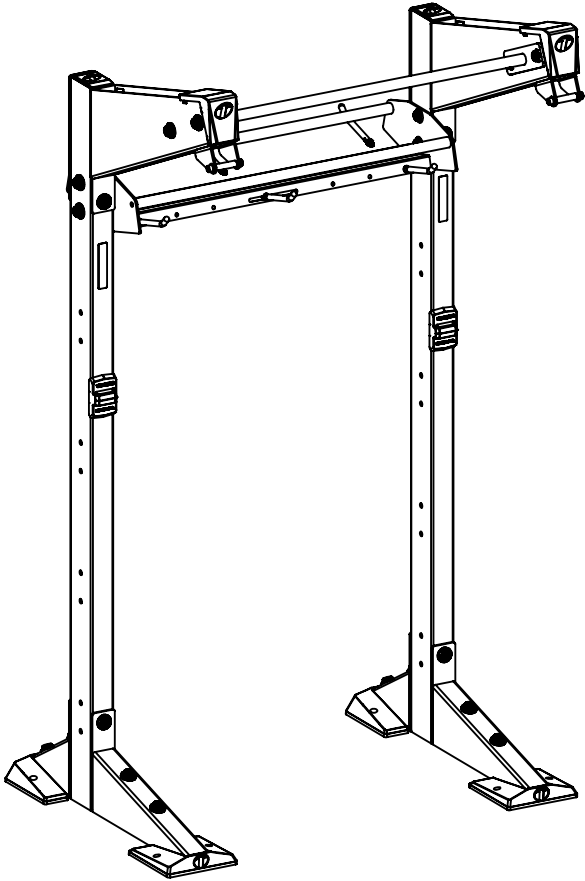

# 4' / 6' UNIVERSAL BALL & HANGING STORAGE MODULE

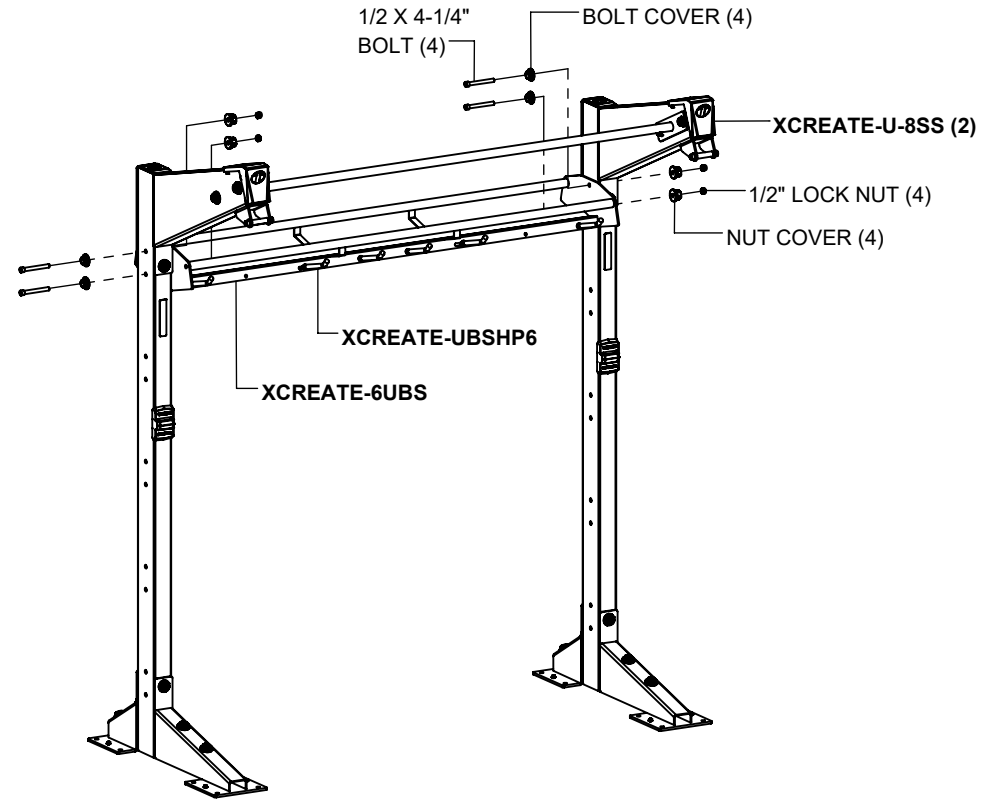
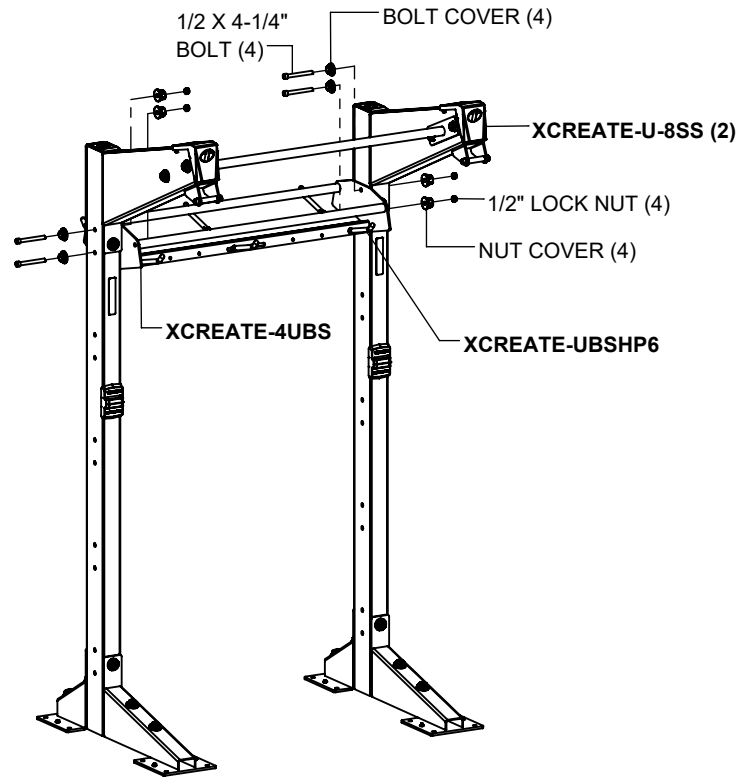

## NOTES:

If more modules will be assembled, do not tighten bolts at this time. If this is the only module being assembled, then **SECURELY** tighten all bolts in this step and previous steps.

The **XCREATE-U-7SS** is assembled the exact same way.

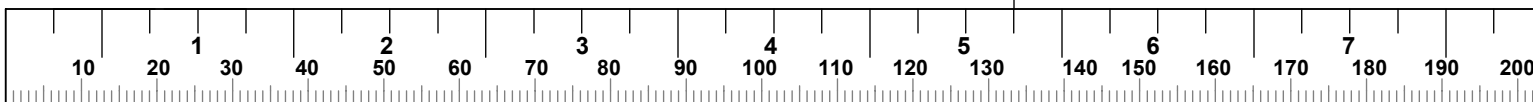

**4' STALL BAR MODULE**

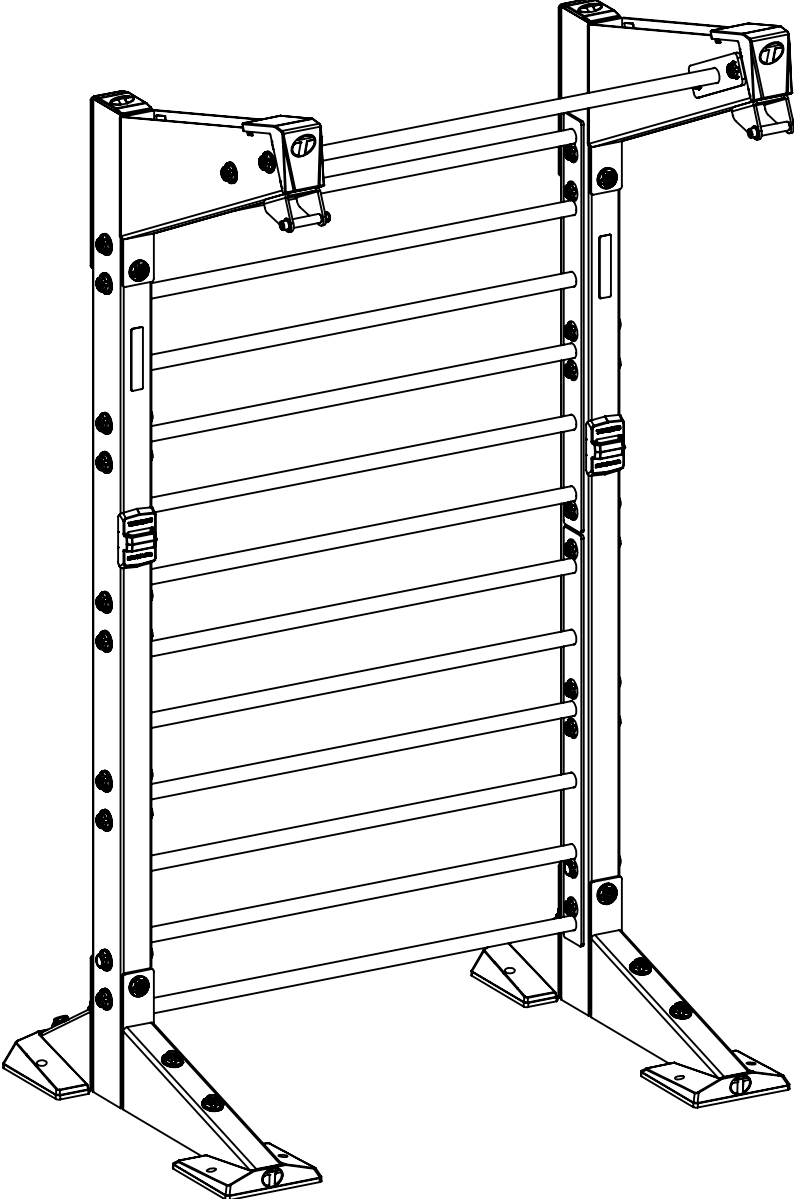

## 4' STALL BAR MODULE

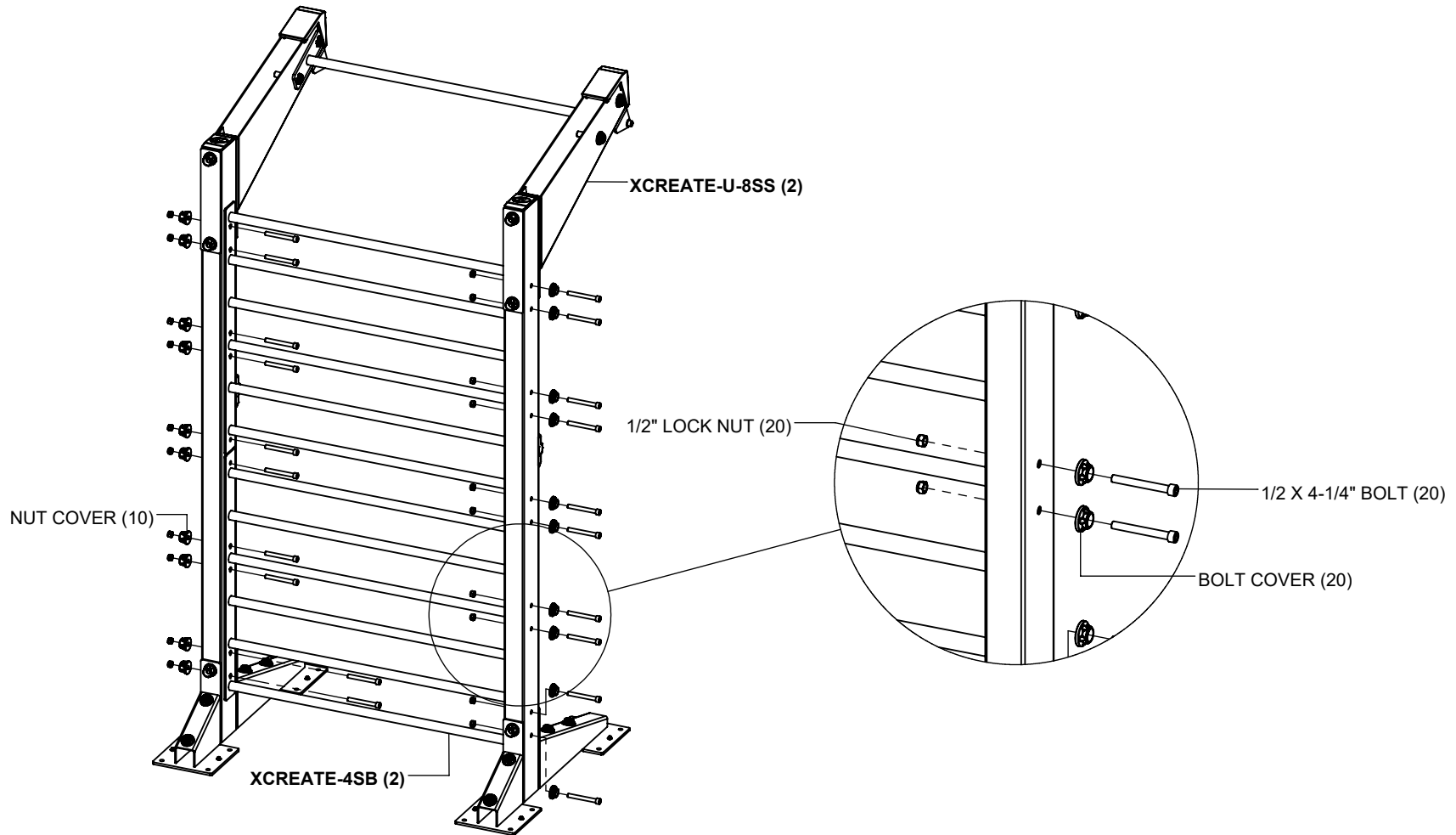

### NOTES:

If more modules will be assembled, do not tighten bolts at this time. If this is the only module being assembled, then **SECURELY** tighten all bolts made in this step and previous steps.

HARDWARE COVERS **CAN** be used in place of washers on tube side only. (SEE PAGE 3).

HARDWARE COVERS **CANNOT** be used on plate side.

The **XCREATE-U-7SS** is assembled the exact same way.

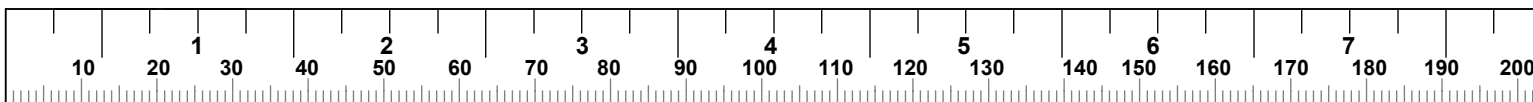

**4' BALL TARGET WALL PAD MODULE**

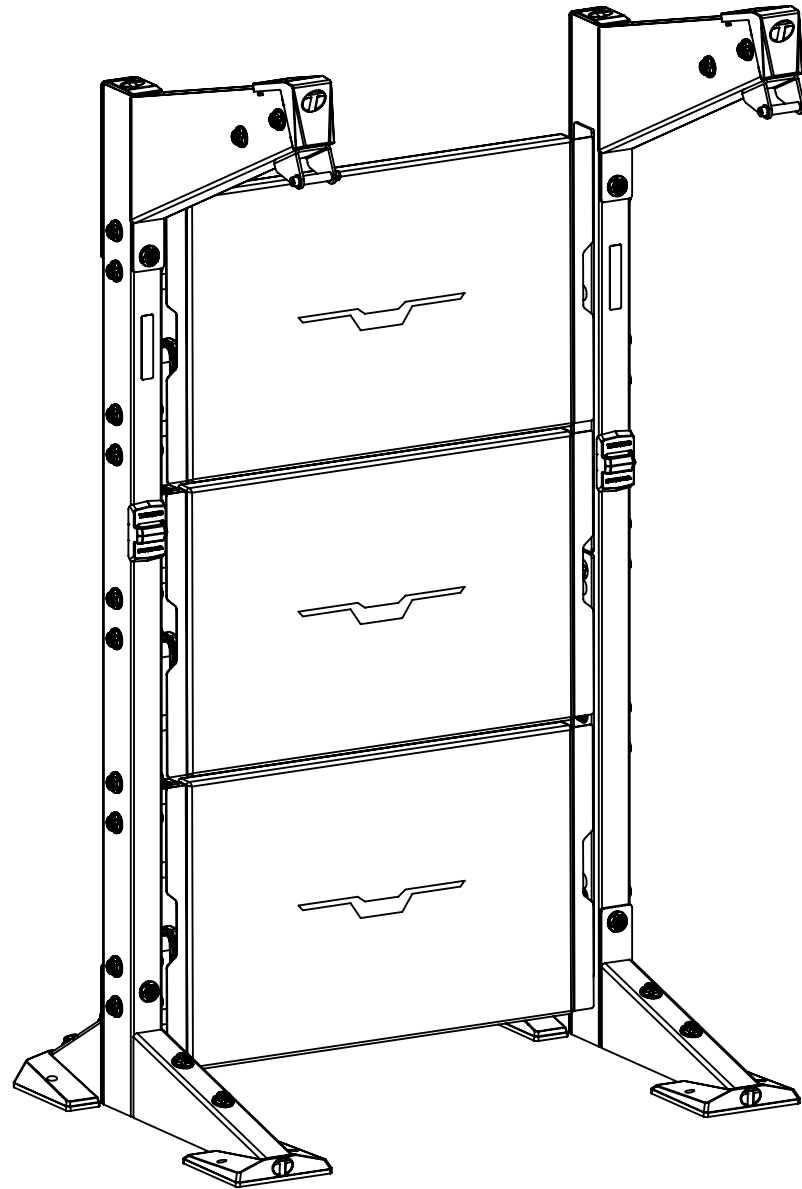

## 4' BALL TARGET WALL PADS

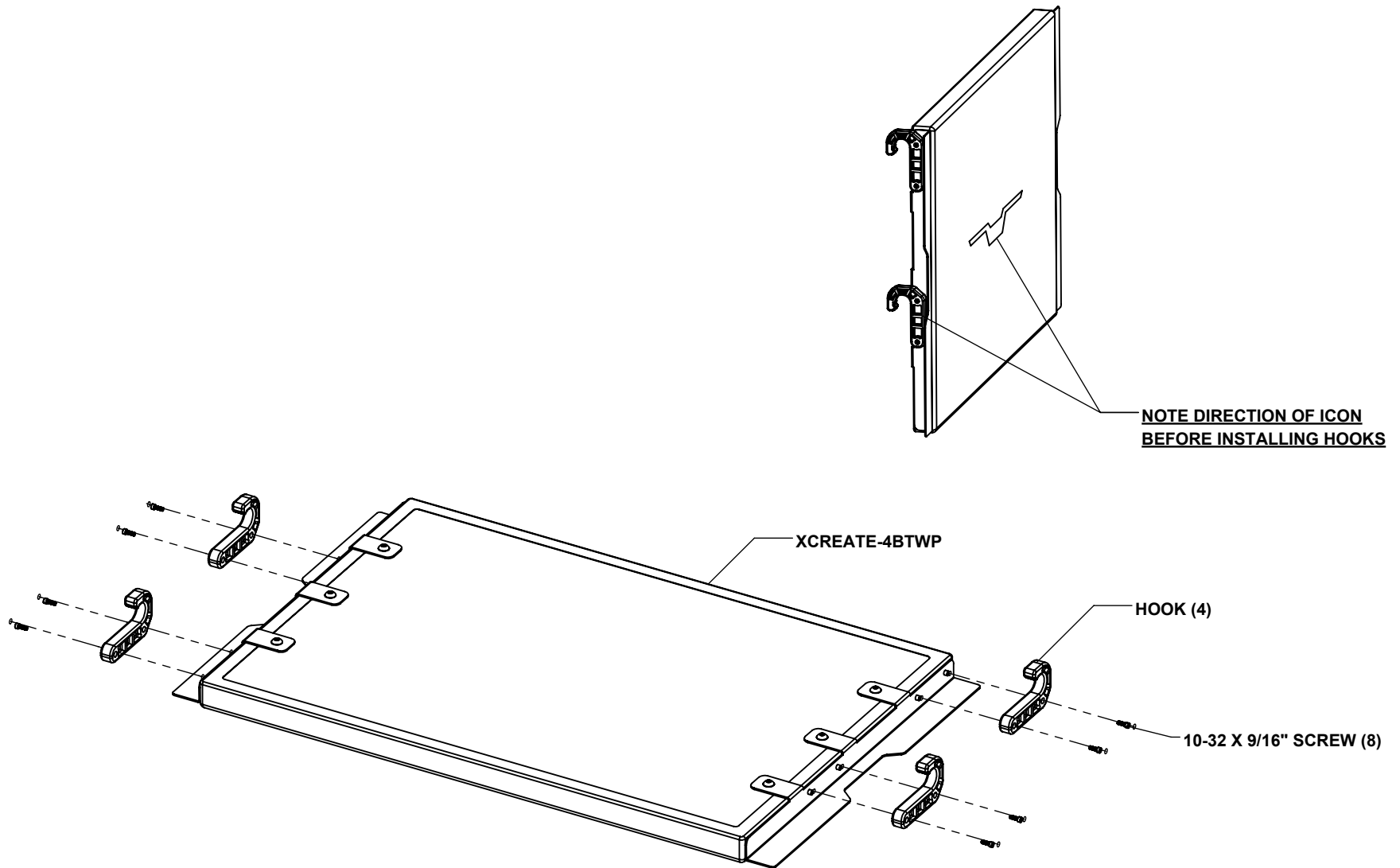

### NOTES:

**SECURELY TIGHTEN, DO NOT OVER TIGHTEN** all bolted connections in this step.

Repeat this step for all ball target pads.

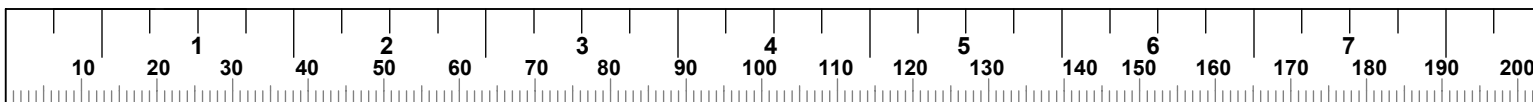



## 4' BALL TARGET WALL PADS

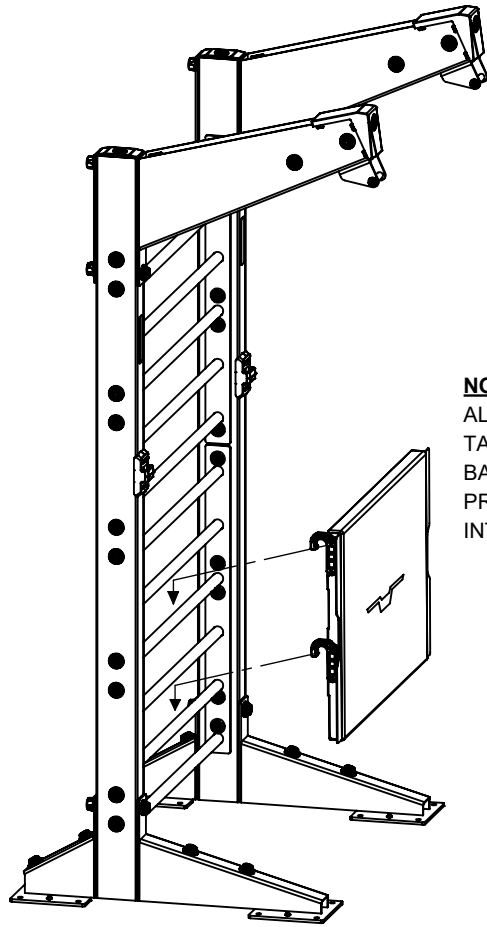

**NOTE:**  
ALIGN AND HOOK BALL  
TARGET PADS OVER STALL  
BAR CROSSMEMBERS.  
PRESS PAD DOWN TO LOCK  
INTO PLACE

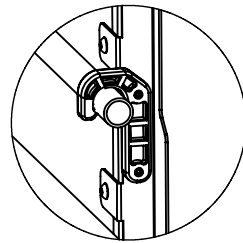

ASSEMBLED  
SECTION VIEW

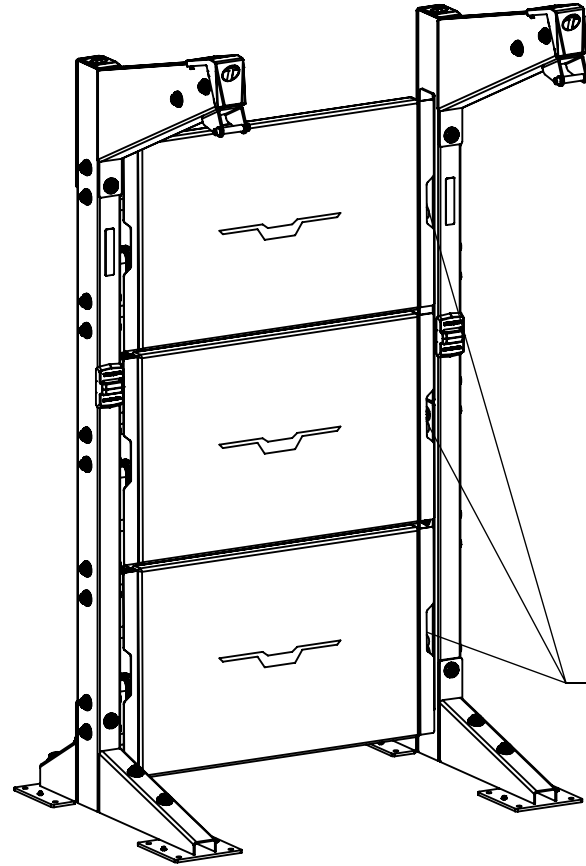

**NOTE:**  
WHEN INSTALLING MULTIPLE  
PADS ALWAYS START WITH  
THE LOWEST PAD.

### NOTES:

**XCREATE 4' STALL BAR MODULE** is required for installing the ball target wall pads. Reference previous steps for installing the stall bars.

Ball target wall pads can be removed and replaced as needed.

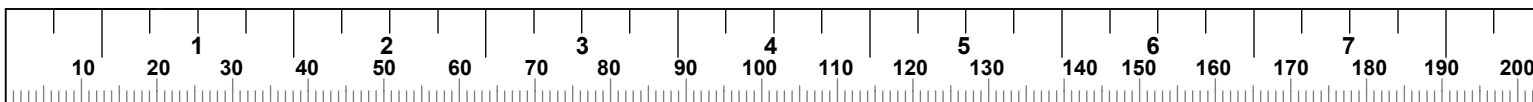

## 8' OLYMPIC LIFTING STATION MODULE

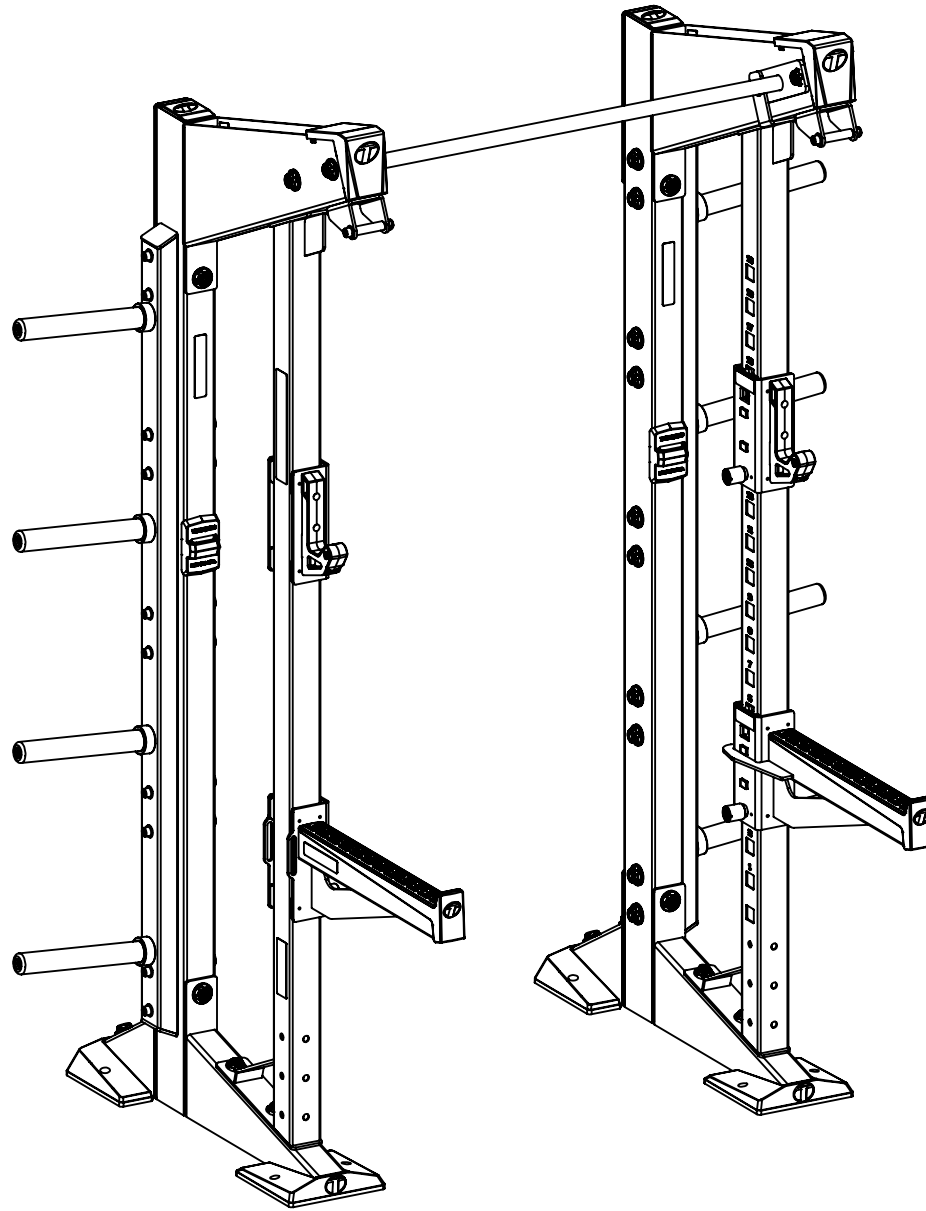

# 8' OLYMPIC LIFTING STATION MODULE

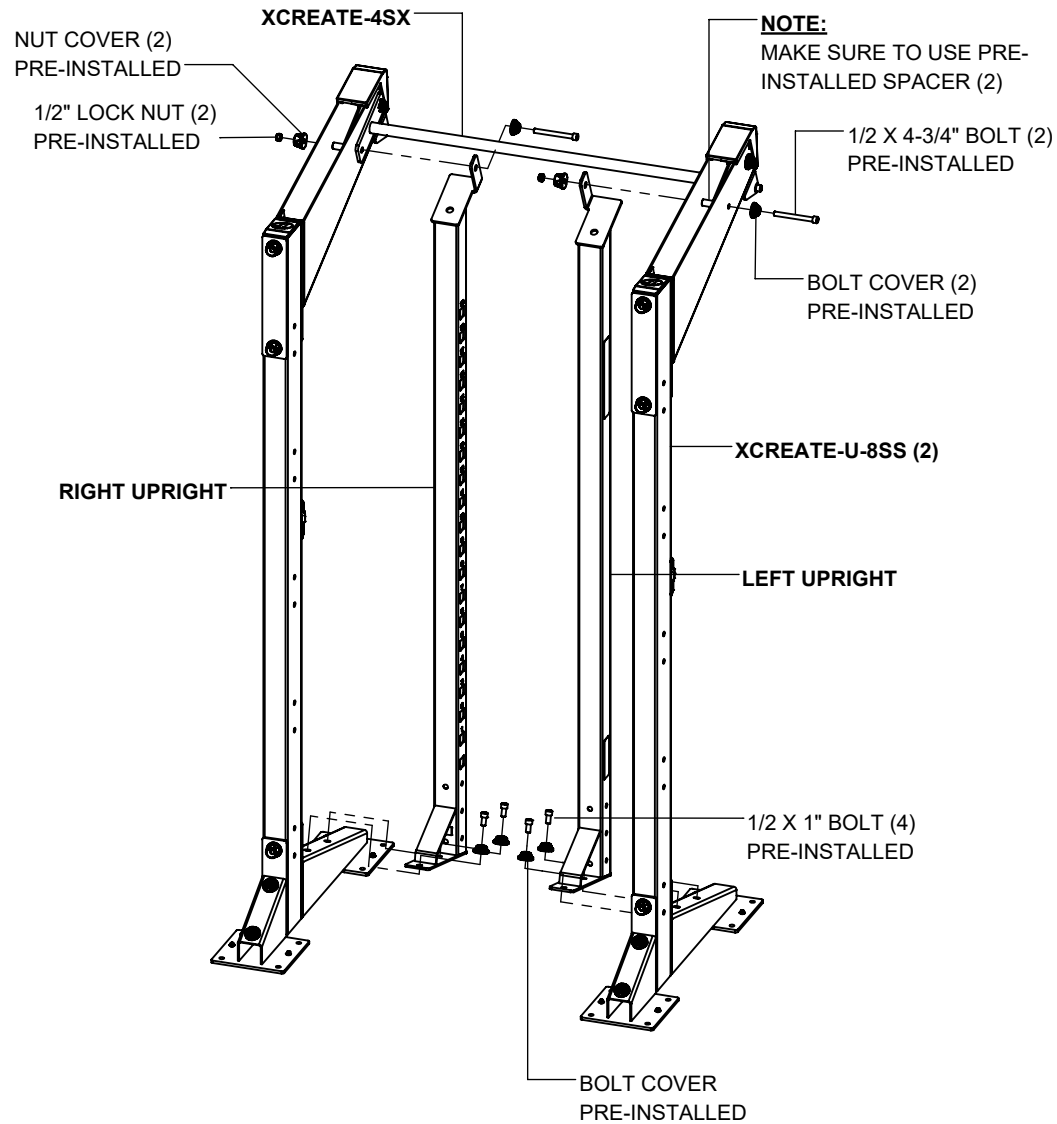

## NOTES:

**SECURELY** tighten all bolt connections in this step.

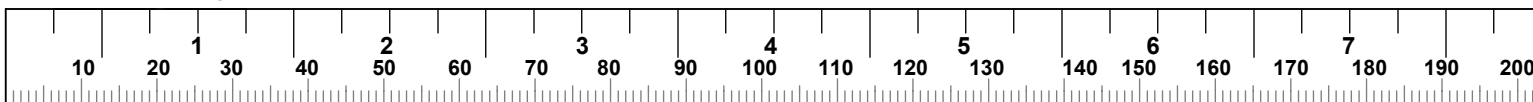

# 8' OLYMPIC LIFTING STATION MODULE

**NOTE:**  
INSERT BAR SUPPORTS INTO  
DESIRED SLOTS ON UPRIGHTS.  
PUSH DOWN TO LOCK IN PLACE

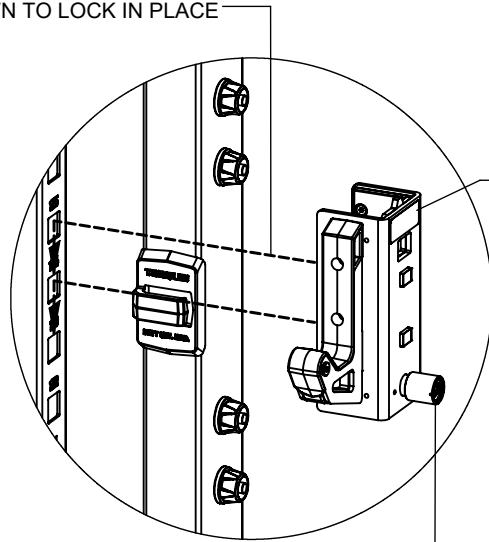

**NOTE:**  
WARNING LABEL

**NOTE:**  
TO REMOVE BAR SUPPORTS FROM  
UPRIGHTS, PULL SPRING PIN OUT TO  
UNLOCK. LIFT UP AND PULL OUT

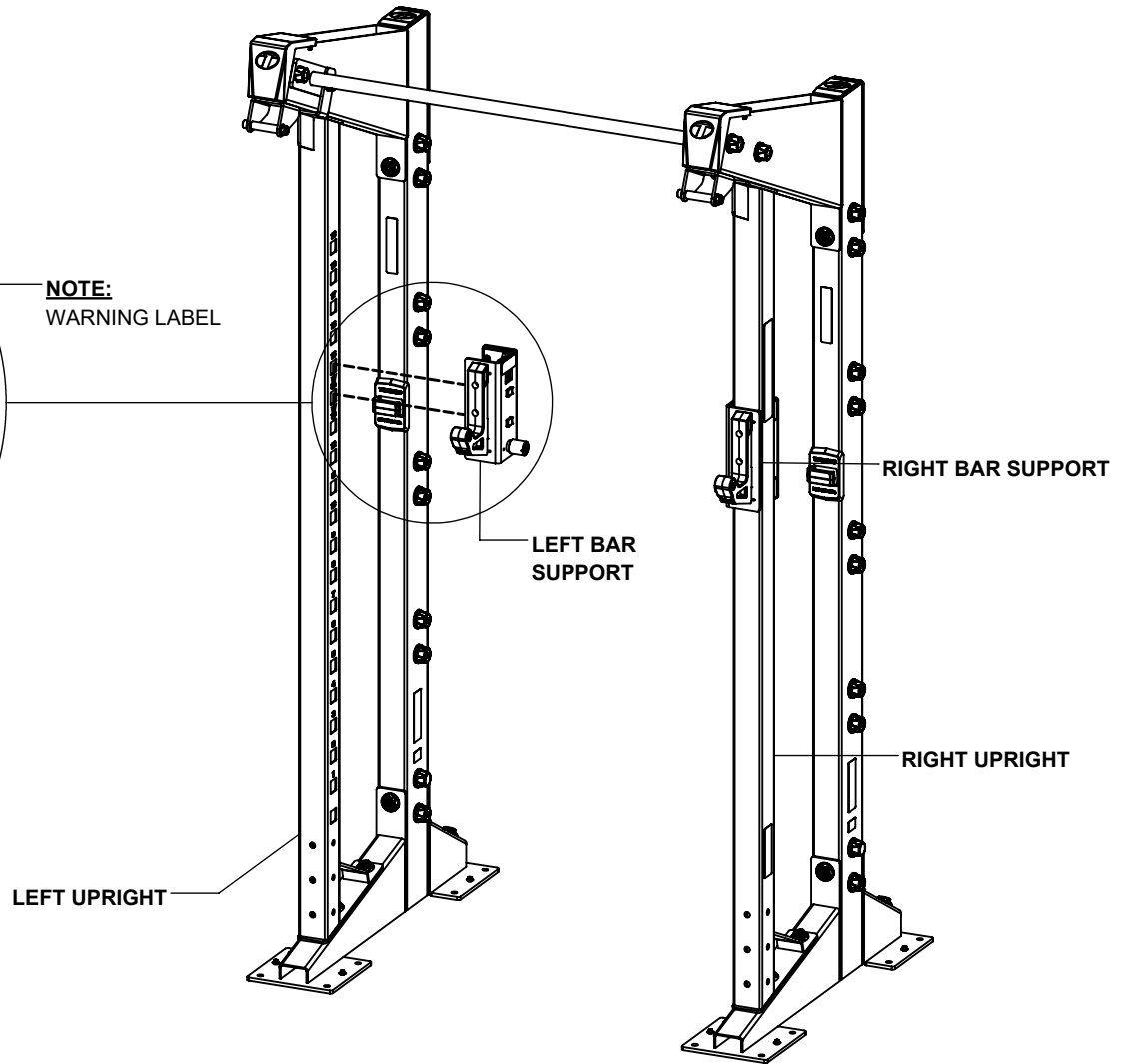

# 8' OLYMPIC LIFTING STATION MODULE

**NOTE:**  
INSERT BAR CATCHES INTO  
DESIRED SLOTS ON UPRIGHTS.  
PUSH DOWN TO LOCK IN PLACE

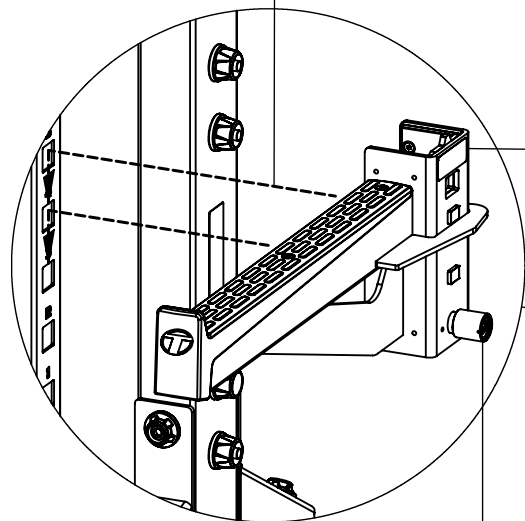

**NOTE:**  
WARNING LABEL

**NOTE:**  
TO REMOVE BAR CATCHES FROM  
UPRIGHTS, PULL SPRING PIN OUT TO  
UNLOCK. LIFT UP AND PULL OUT

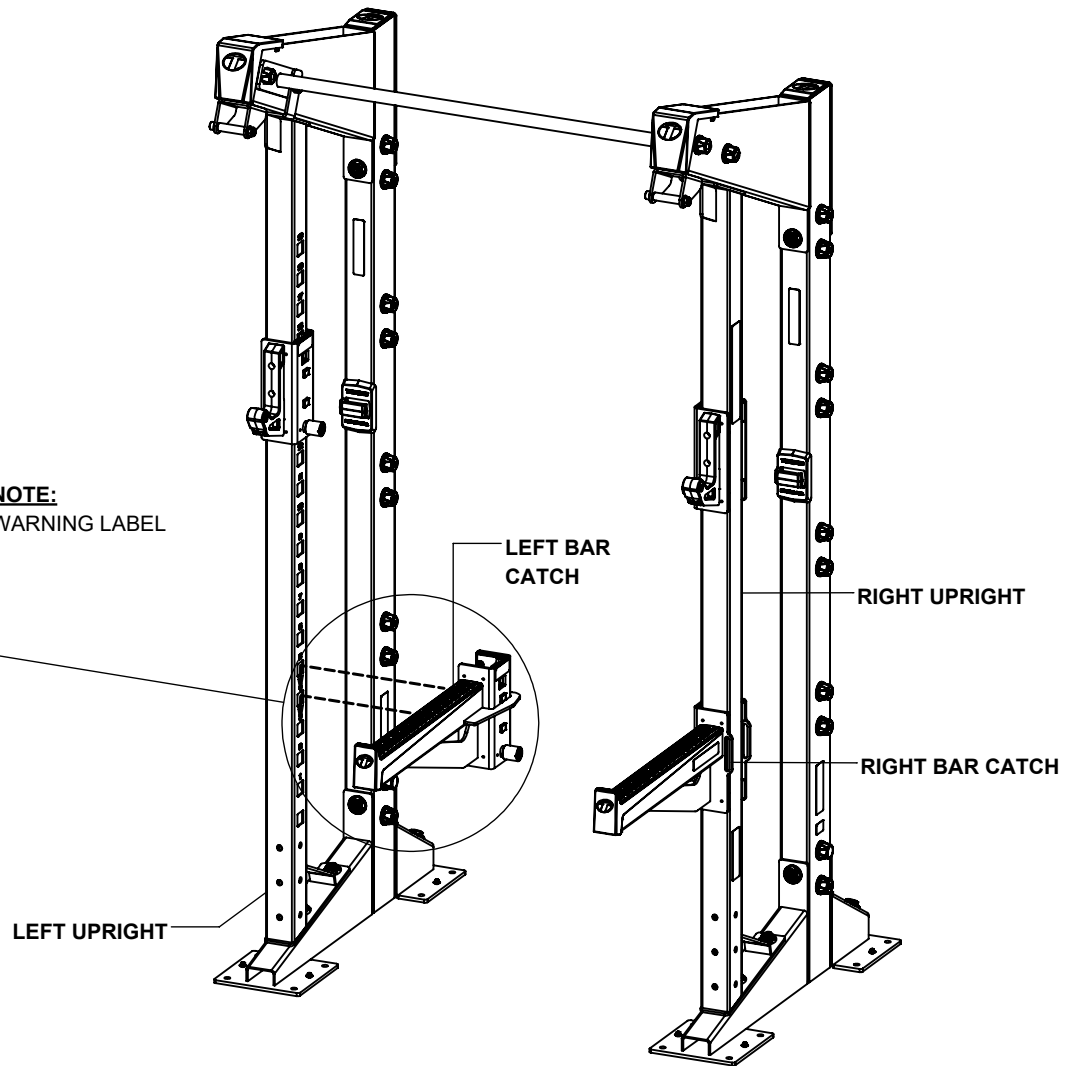

# 8' OLYMPIC LIFTING STATION MODULE

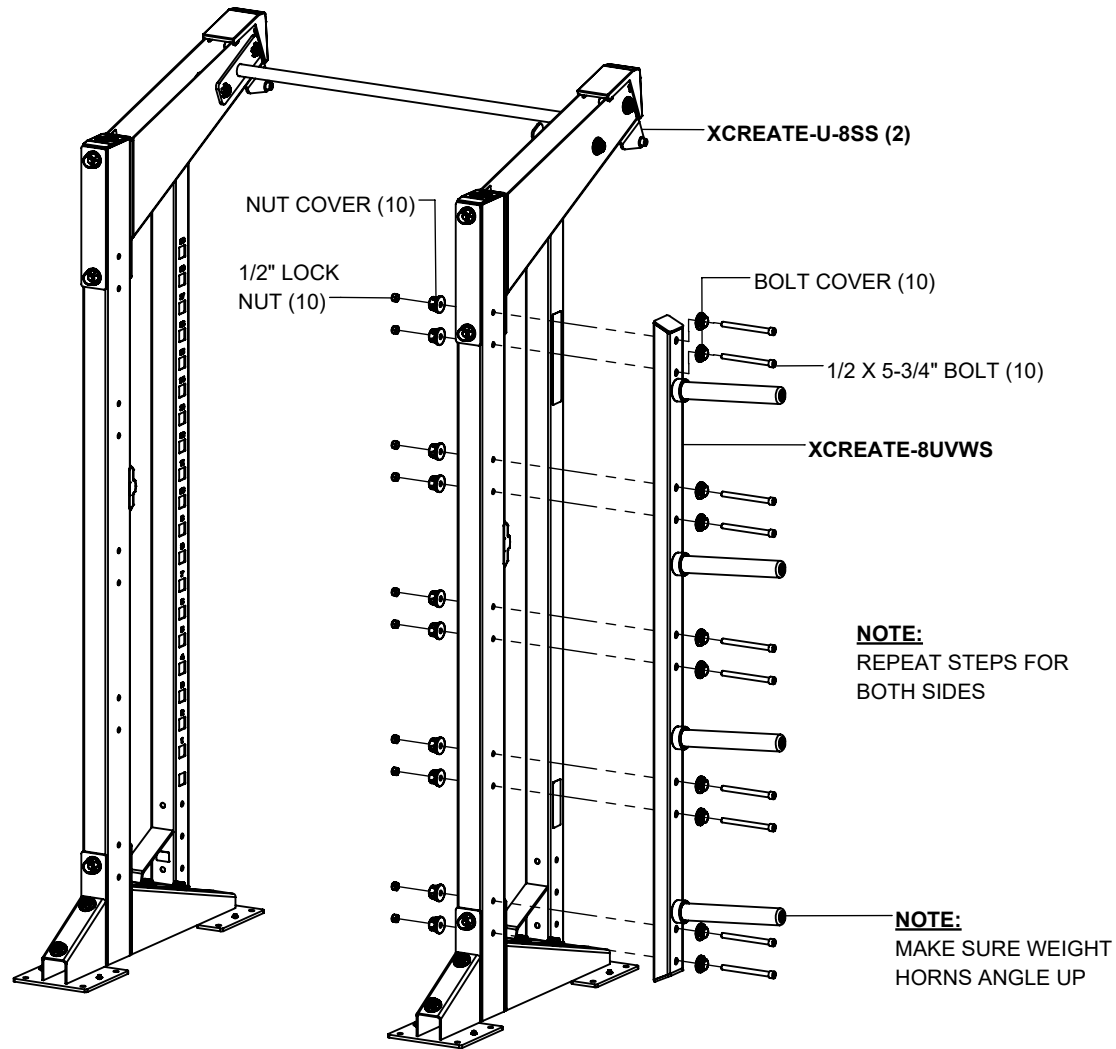

## NOTES:

**SECURELY** tighten all bolt connections in this step.

**REPEAT STEPS** for both sides as needed.

The **XCREATE-U-7SS** is assembled the exact same way.

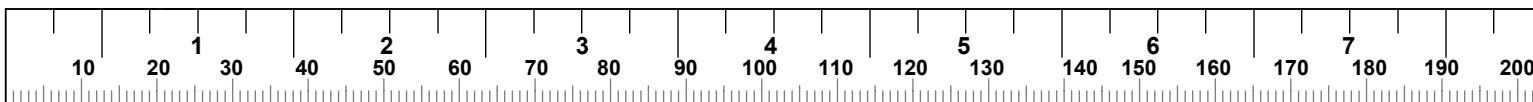

**4' / 6' ACCESSORY & BUMPER BOOKSHELF  
STORAGE MODULE**

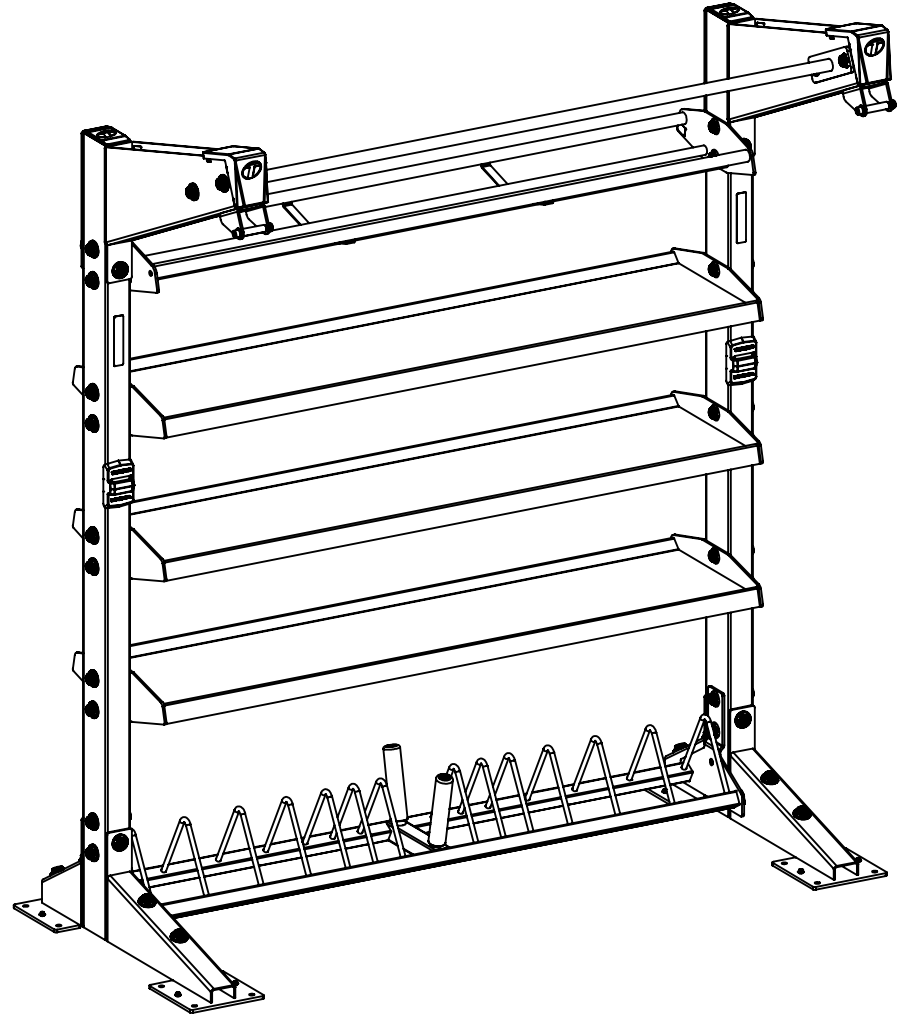
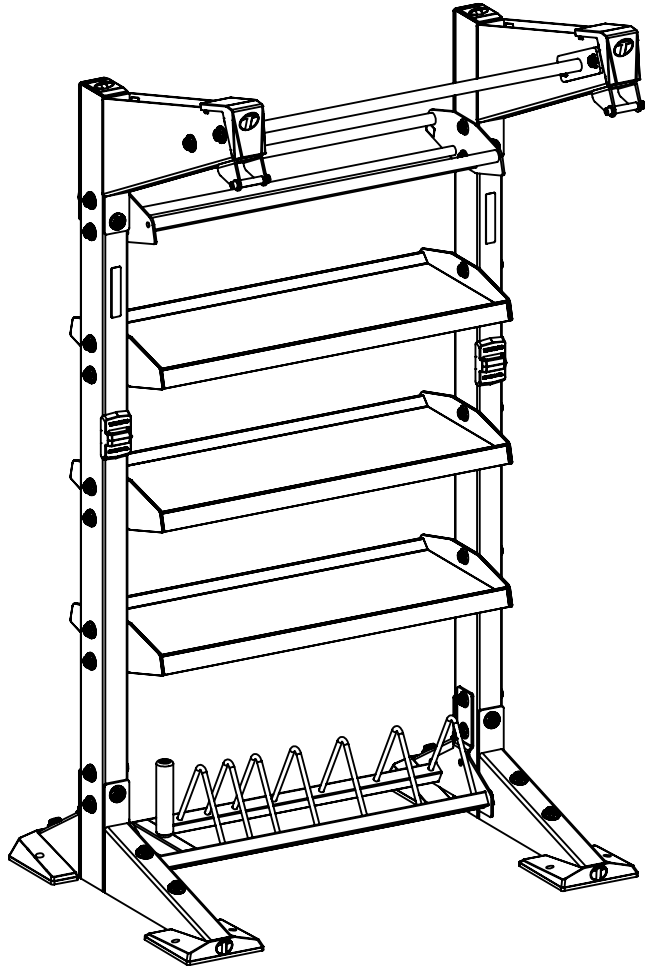

# 4' / 6' ACCESSORY & BUMPER BOOKSHELF STORAGE MODULE

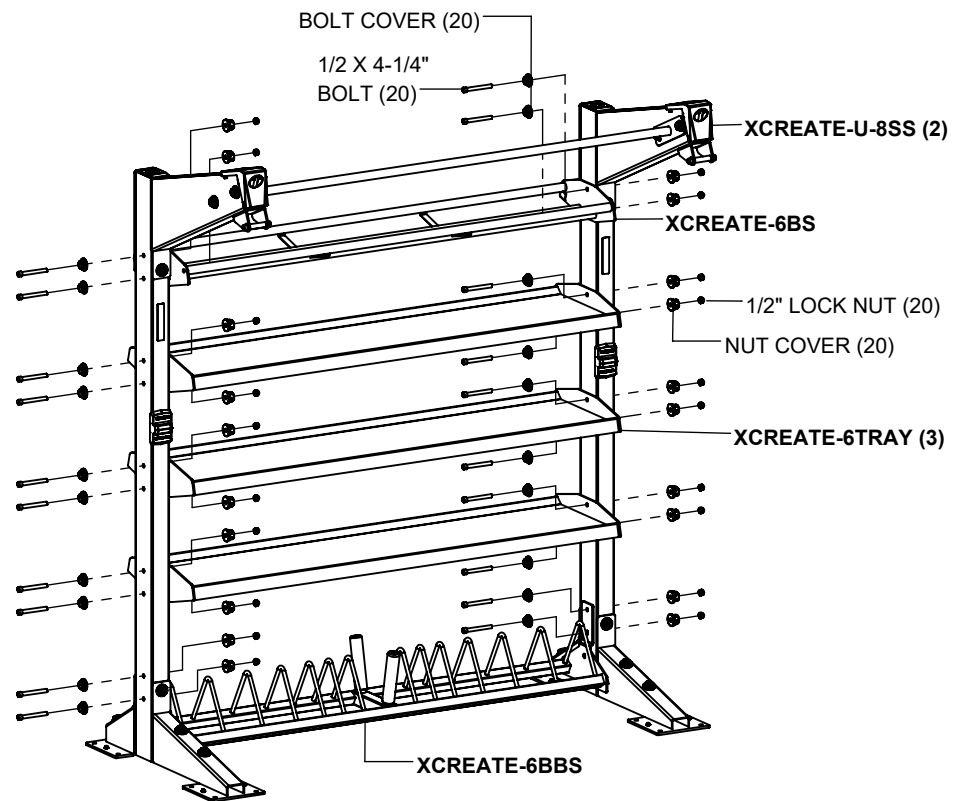
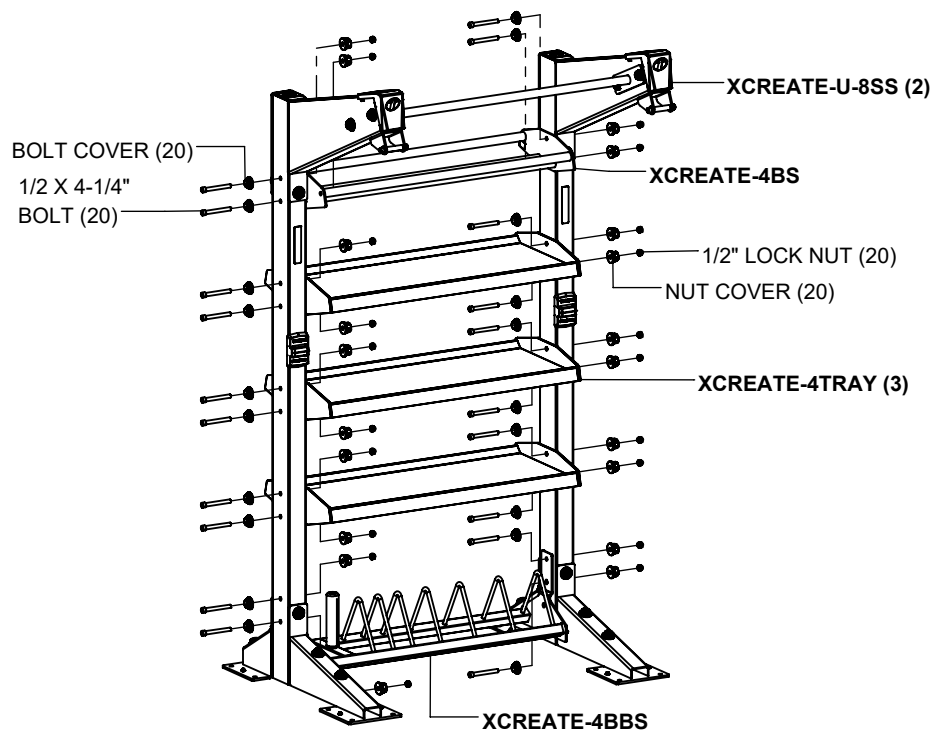

## NOTES:

If more modules will be assembled, do not tighten bolts at this time. If this is the only module being assembled, then **SECURELY** tighten all bolts in this step and previous steps.

The **XCREATE-U-7SS** is assembled the exact same way.

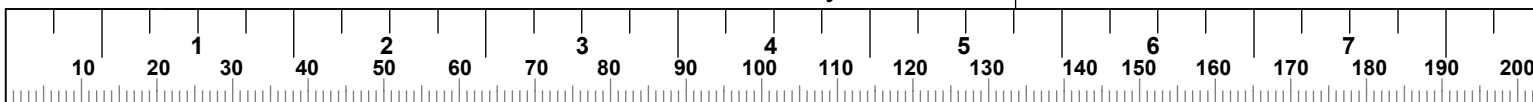



**4' TANK DOCKING MODULE**

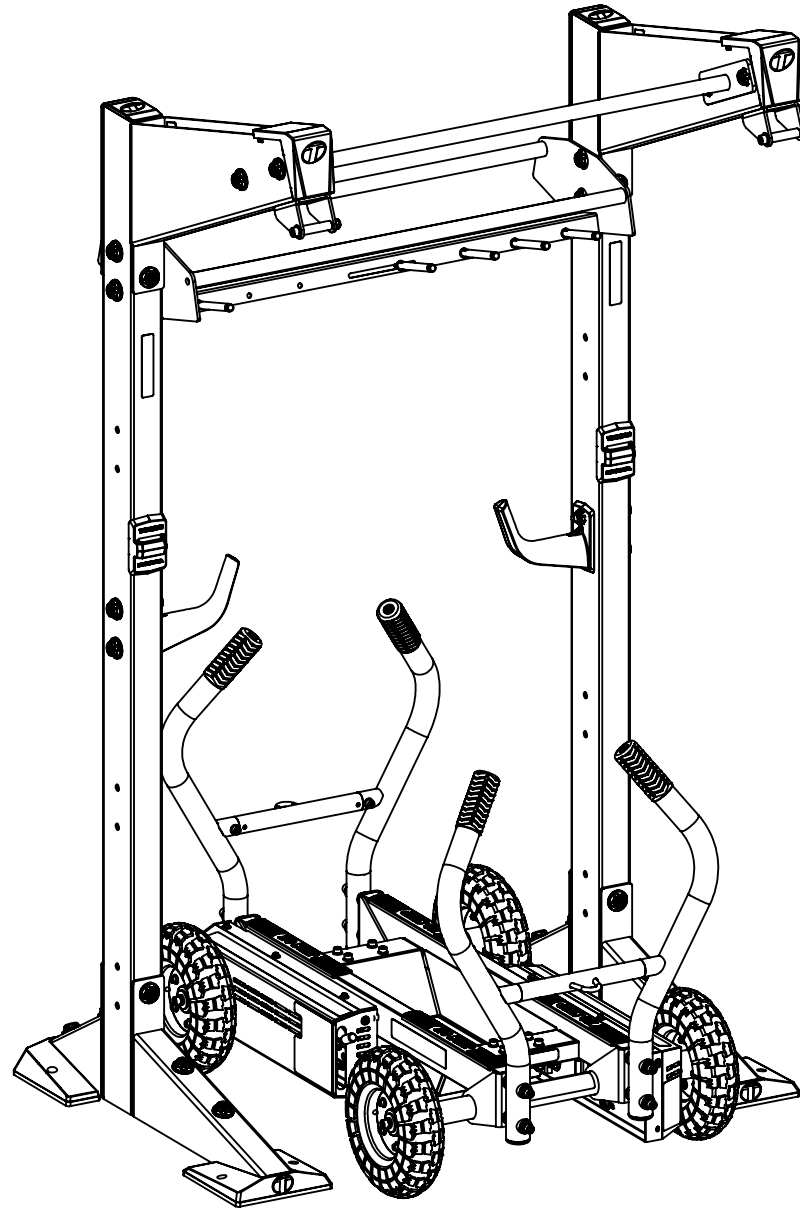

## 4' TANK DOCKING MODULE

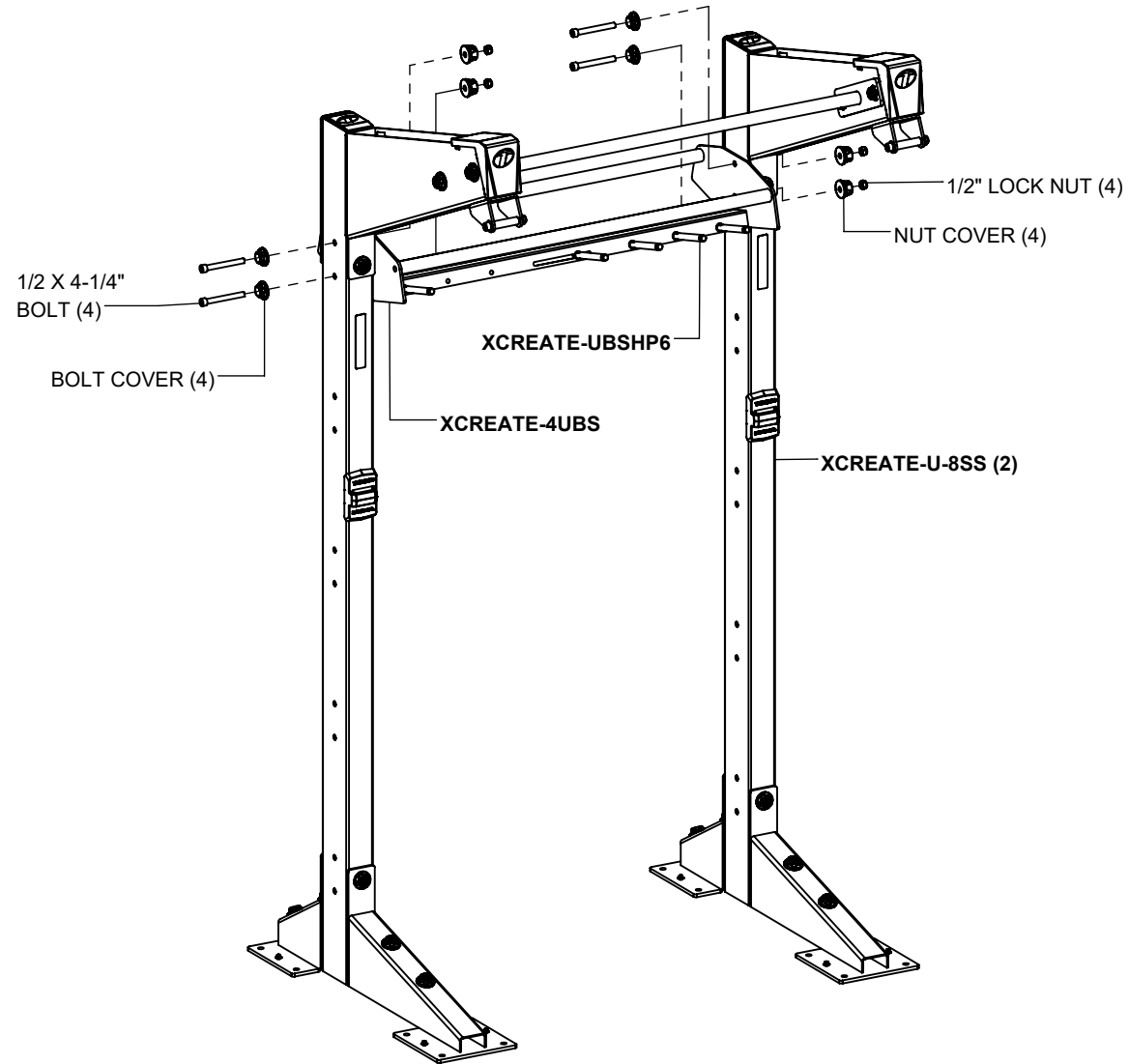

### NOTES:

If more modules will be assembled, do not tighten bolts at this time.  
If this is the only module being assembled, then **SECURELY** tighten all bolts in this step and previous steps.

The **XCREATE-U-7SS** is assembled the exact same way.

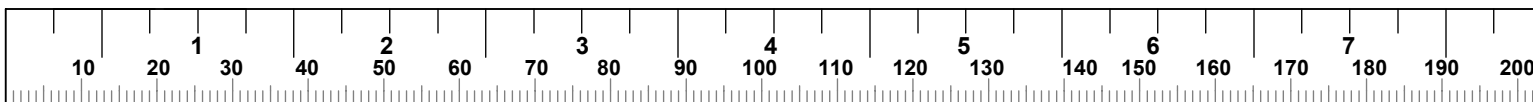

## 4' TANK DOCKING MODULE

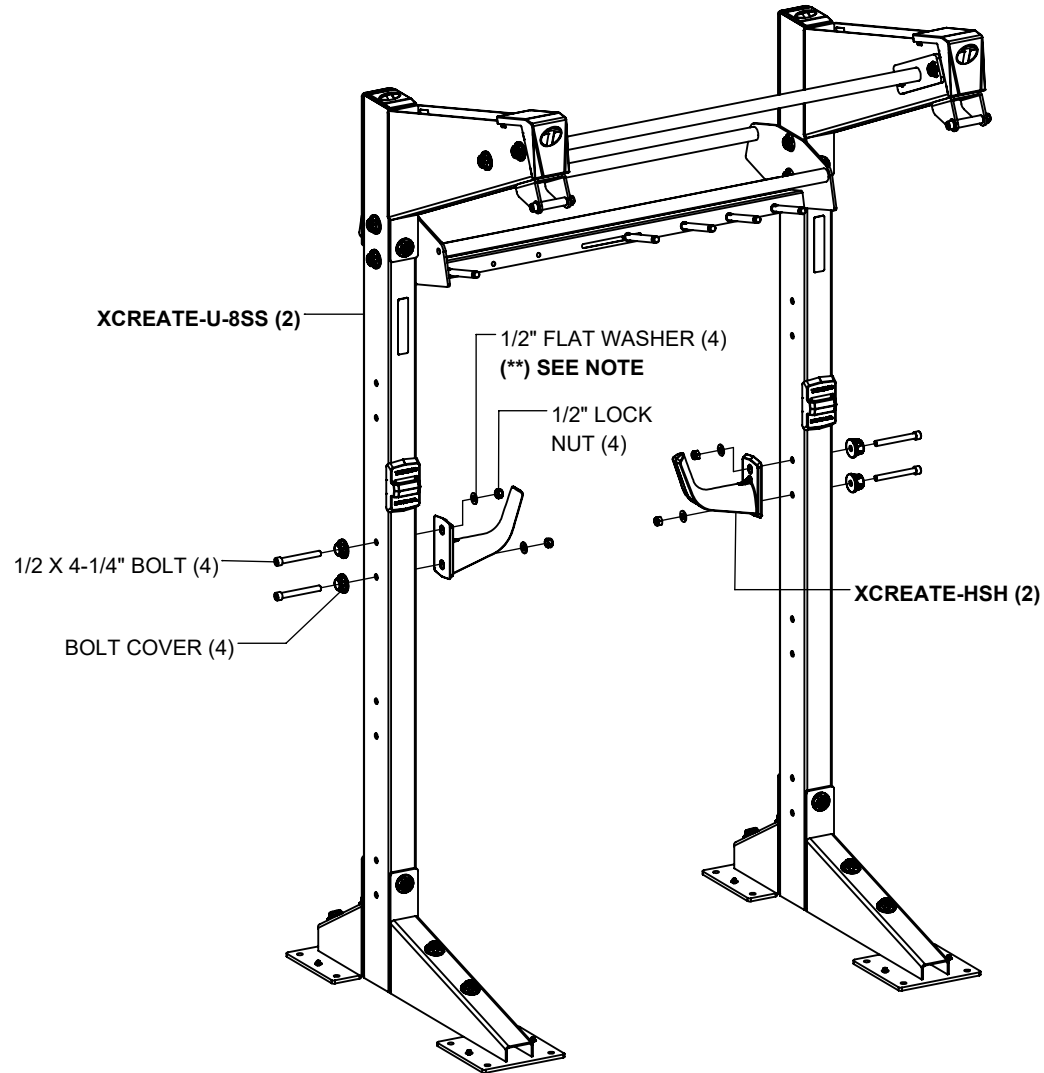

### NOTES:

**SECURELY** tighten all bolt connections in this step.

(\*\*) HARDWARE COVER **CANNOT** be used on **HSH** side.

The **XCREATE-U-7SS** is assembled the exact same way.

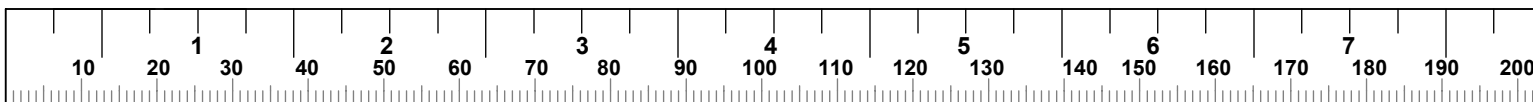

## 4' TANK DOCKING MODULE

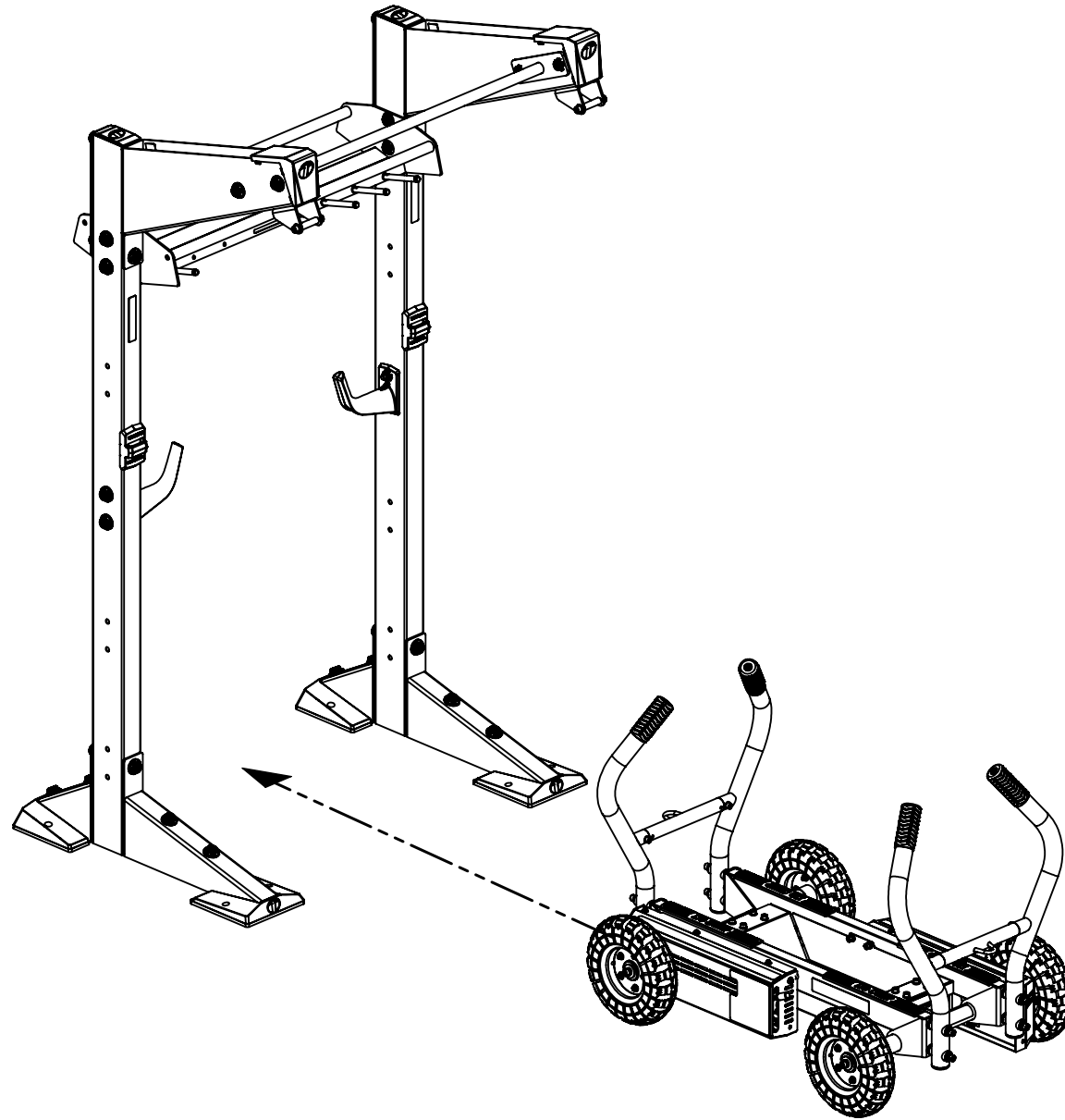

**4' X 5 BARBELL STORAGE MODULE**

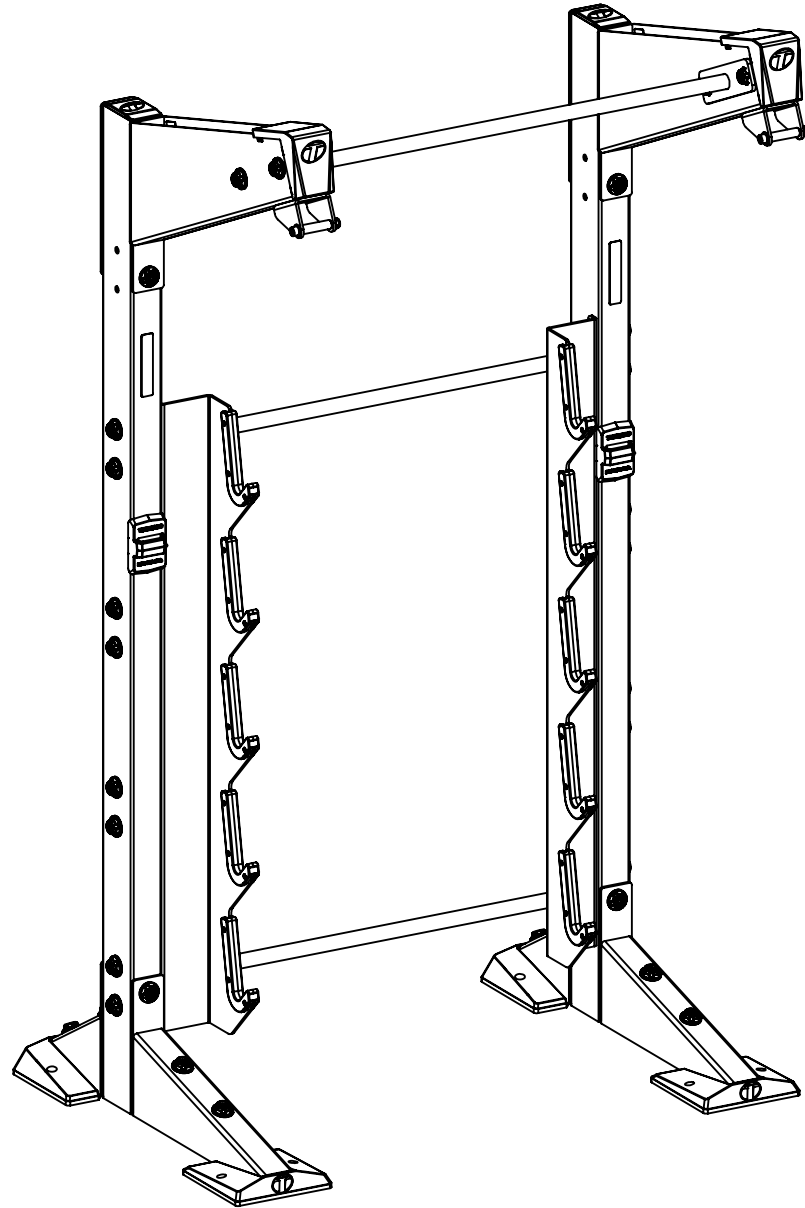

## 4' X 5 BARBELL STORAGE MODULE (WITHOUT CONNECTOR)

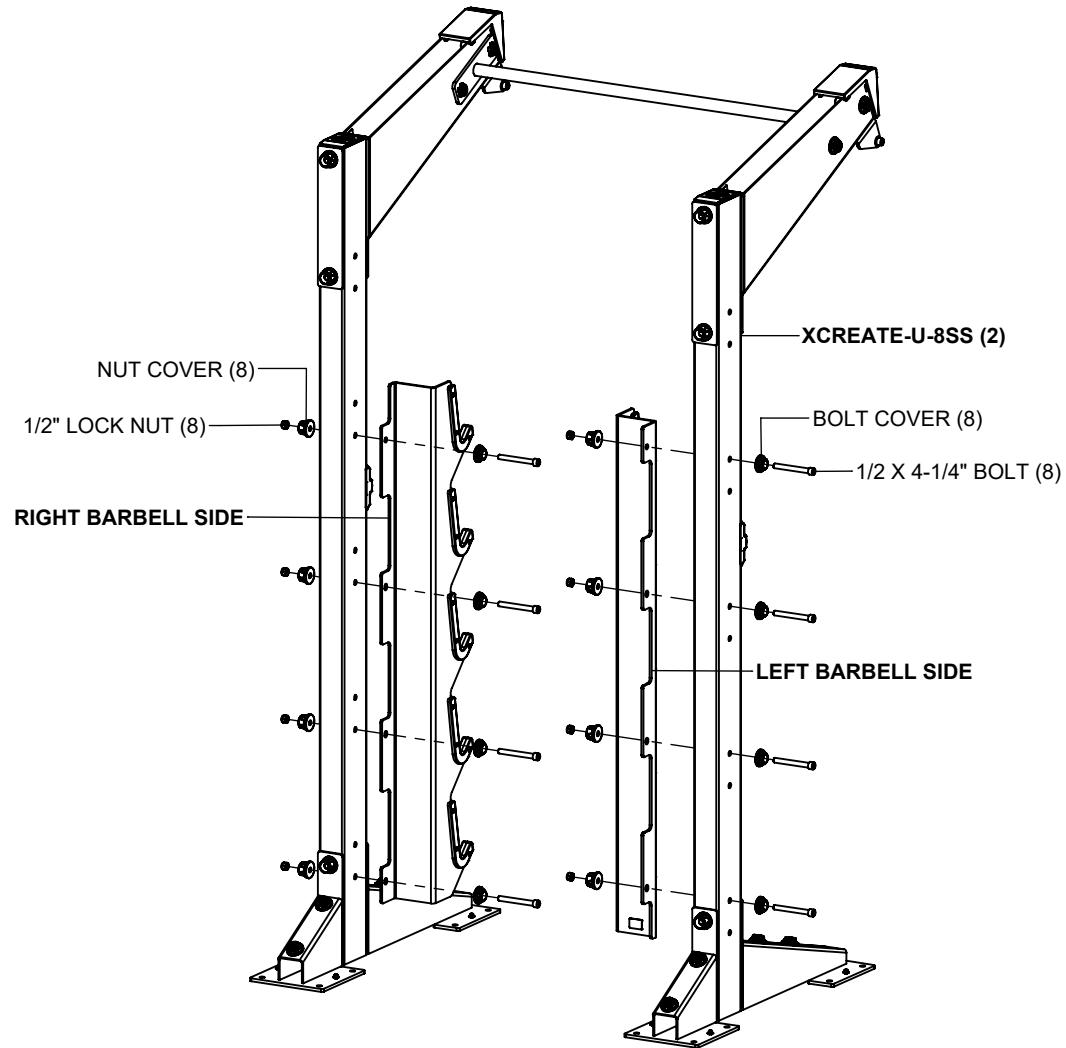

### NOTES:

If more modules will be assembled, do not tighten bolts at this time.  
If this is the only module being assembled, then **SECURELY** tighten all bolts in this step and previous steps.

The **XCREATE-U-7SS** is assembled the exact same way.

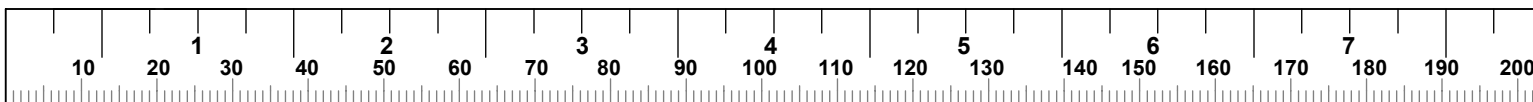

# 4' X 5' BARBELL STORAGE MODULE (WITH CONNECTOR)

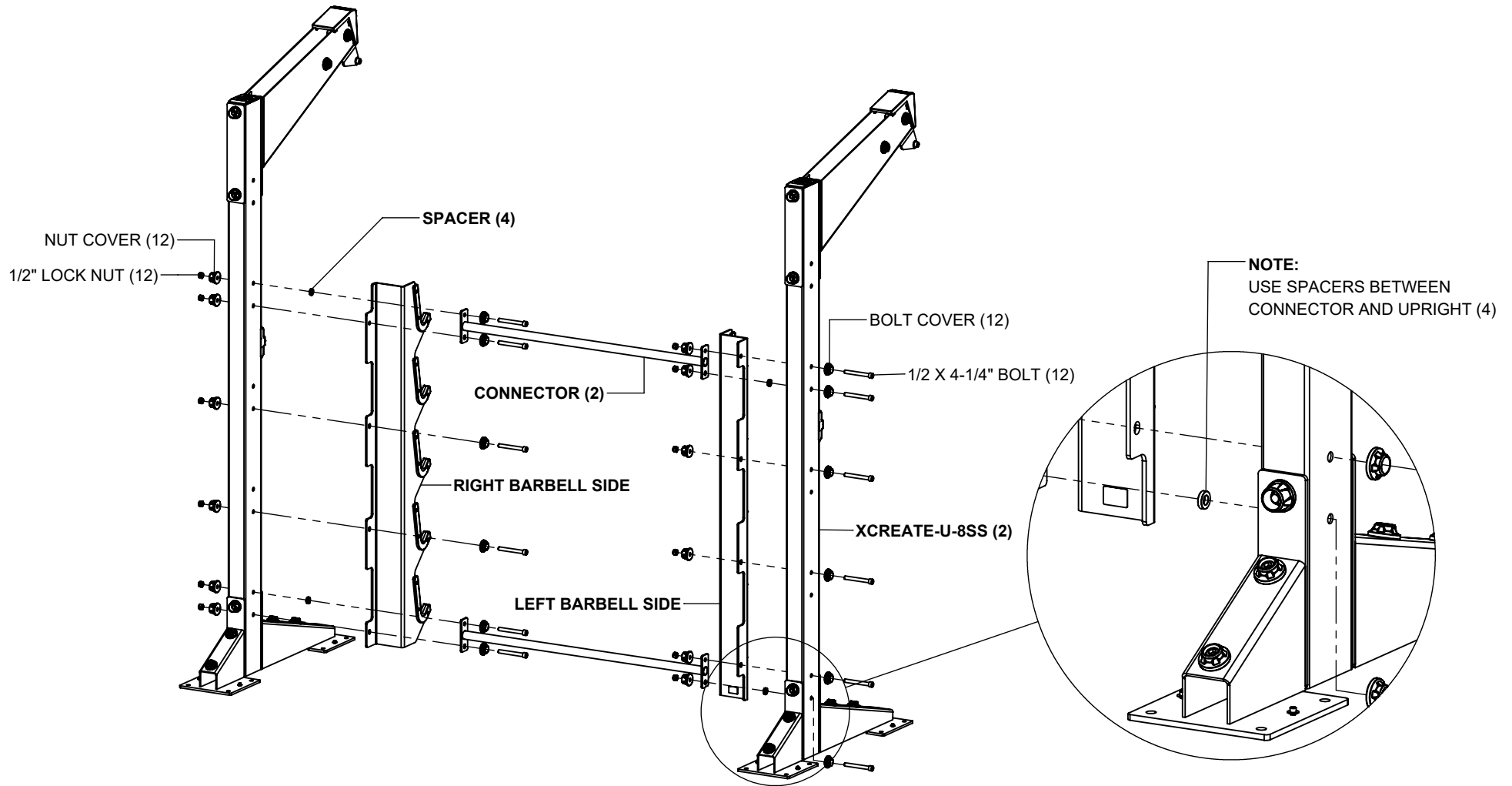

## NOTES:

If more modules will be assembled, do not tighten bolts at this time. If this is the only module being assembled, then **SECURELY** tighten all bolts in this step and previous steps.

The **XCREATE-U-7SS** is assembled the exact same way.

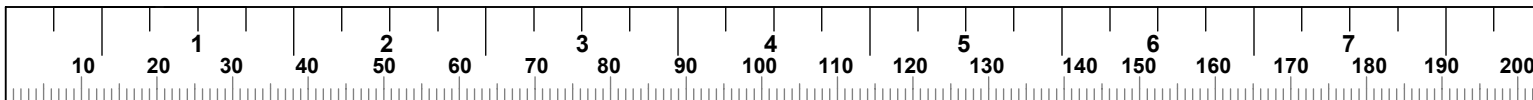

## 4' X 5 BARBELL STORAGE MODULE

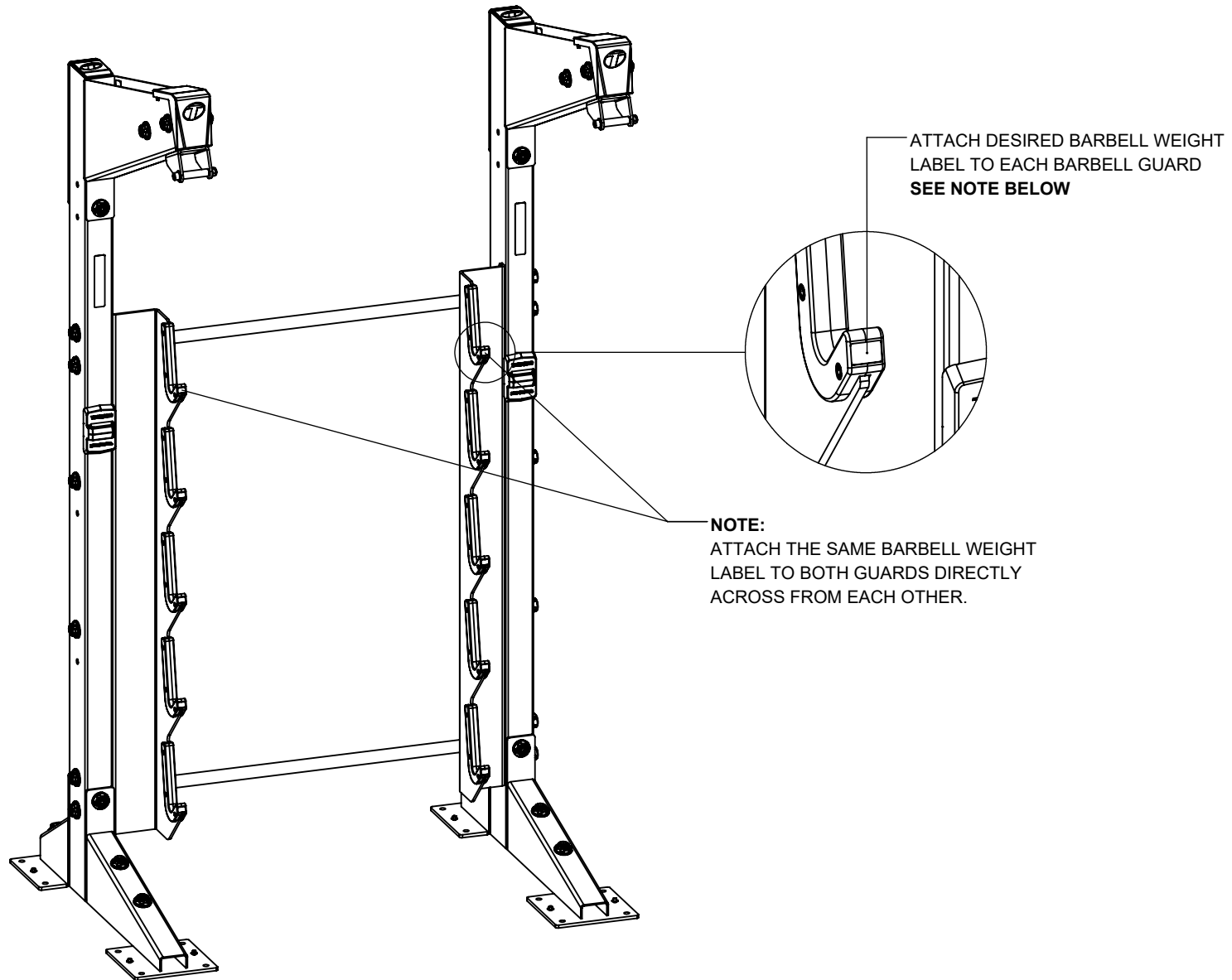

### **NOTE:**

If you are a professional contractor installing this system for a facility, leave these labels and instruction with manager or inquire what label to attach to each barbell guard.



**4' X 10 BARBELL STORAGE MODULE**

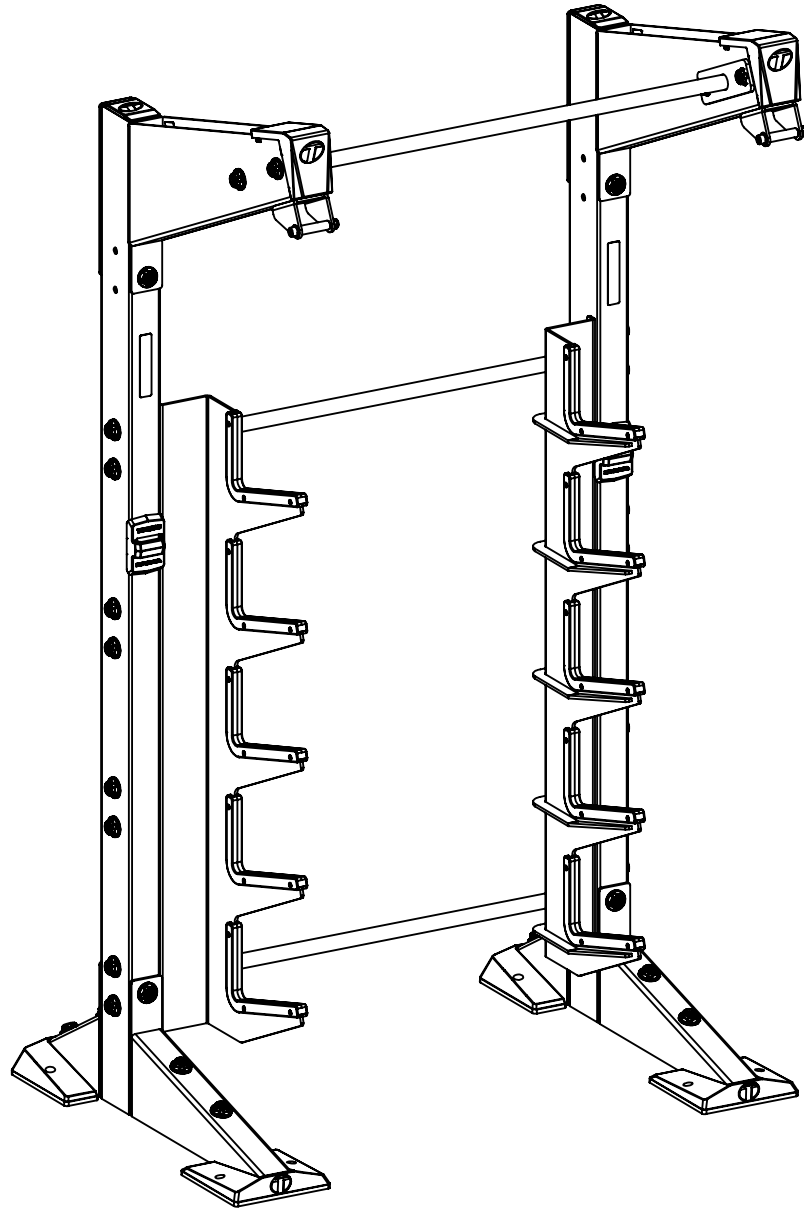

## 4' X 10 BARBELL STORAGE MODULE (WITHOUT CONNECTOR)

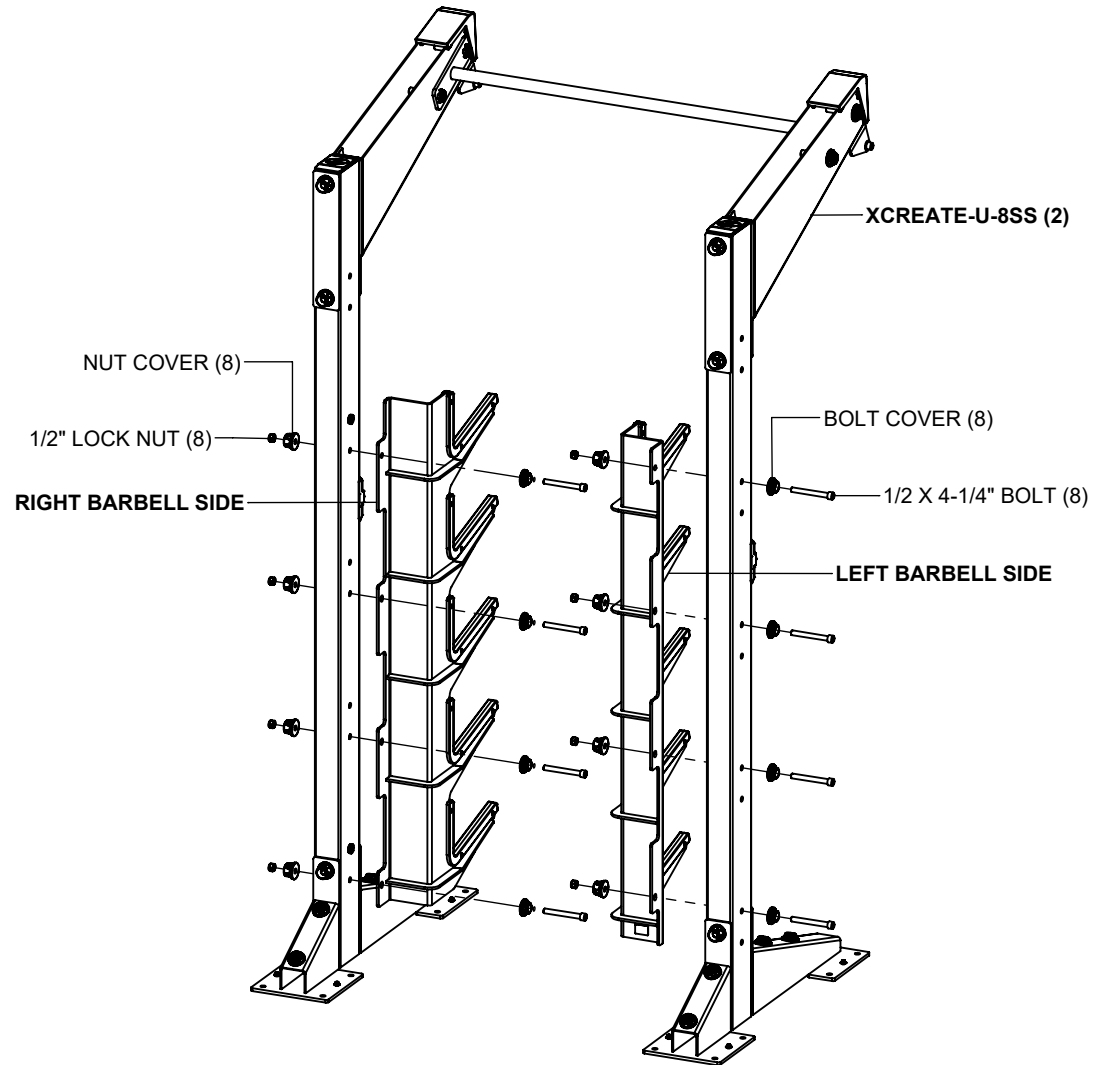

### NOTES:

If more modules will be assembled, do not tighten bolts at this time.  
If this is the only module being assembled, then **SECURELY** tighten all bolts in this step and previous steps.

The **XCREATE-U-7SS** is assembled the exact same way.

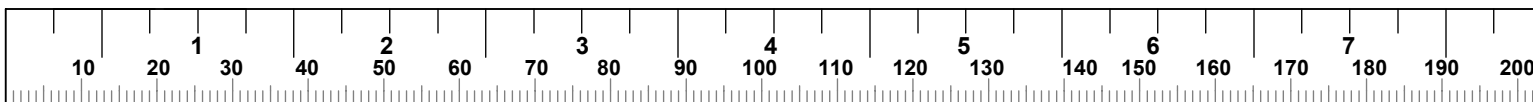

# 4' X 10 BARBELL STORAGE MODULE (WITH CONNECTOR)

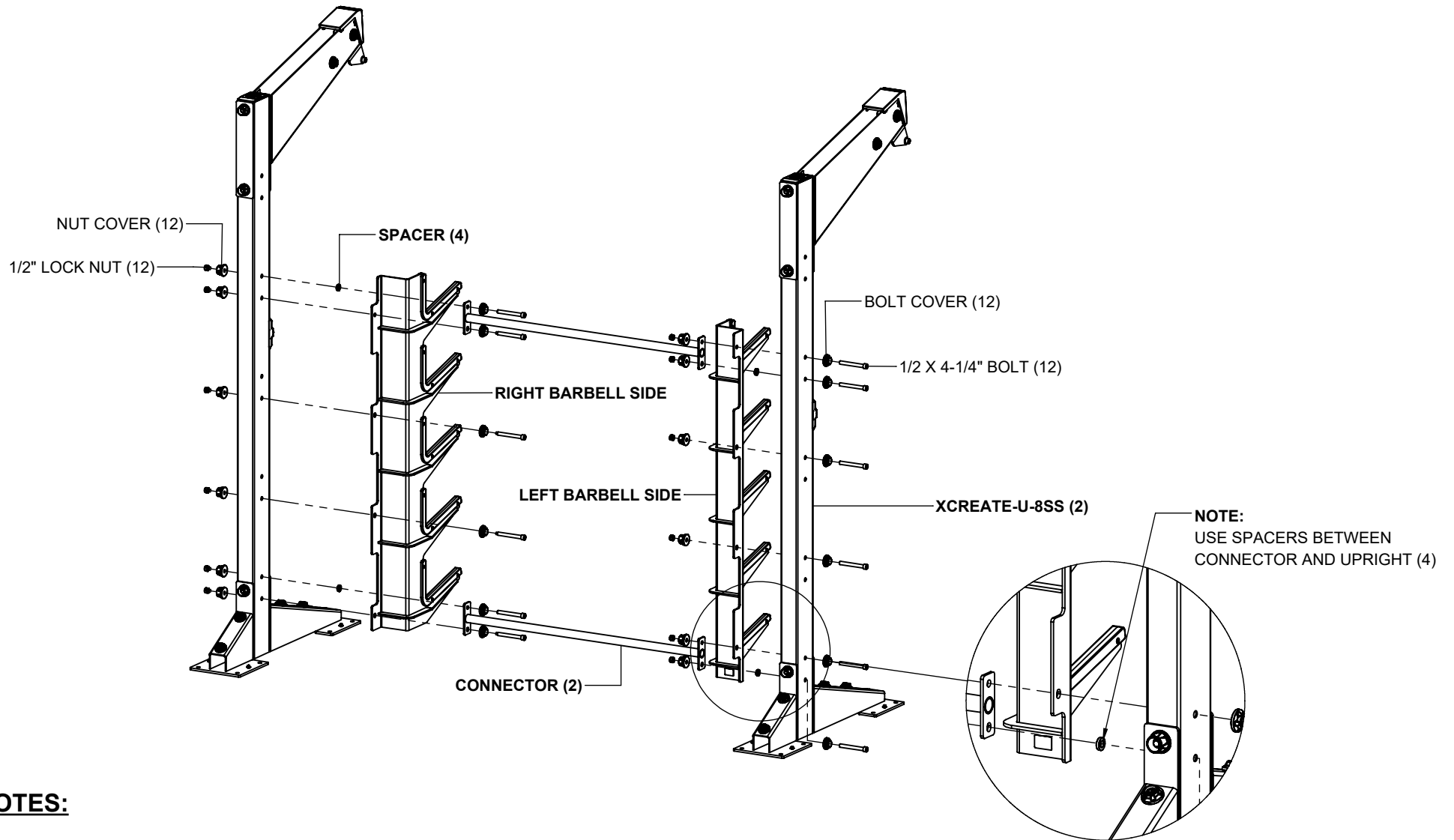

## NOTES:

If more modules will be assembled, do not tighten bolts at this time.  
If this is the only module being assembled, then **SECURELY** tighten all bolts in this step and previous steps.

The **XCREATE-U-7SS** is assembled the exact same way.

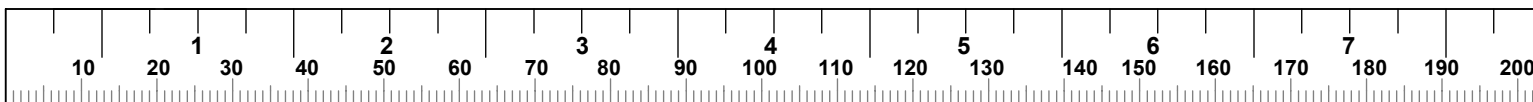

## 4' X 10 BARBELL STORAGE MODULE

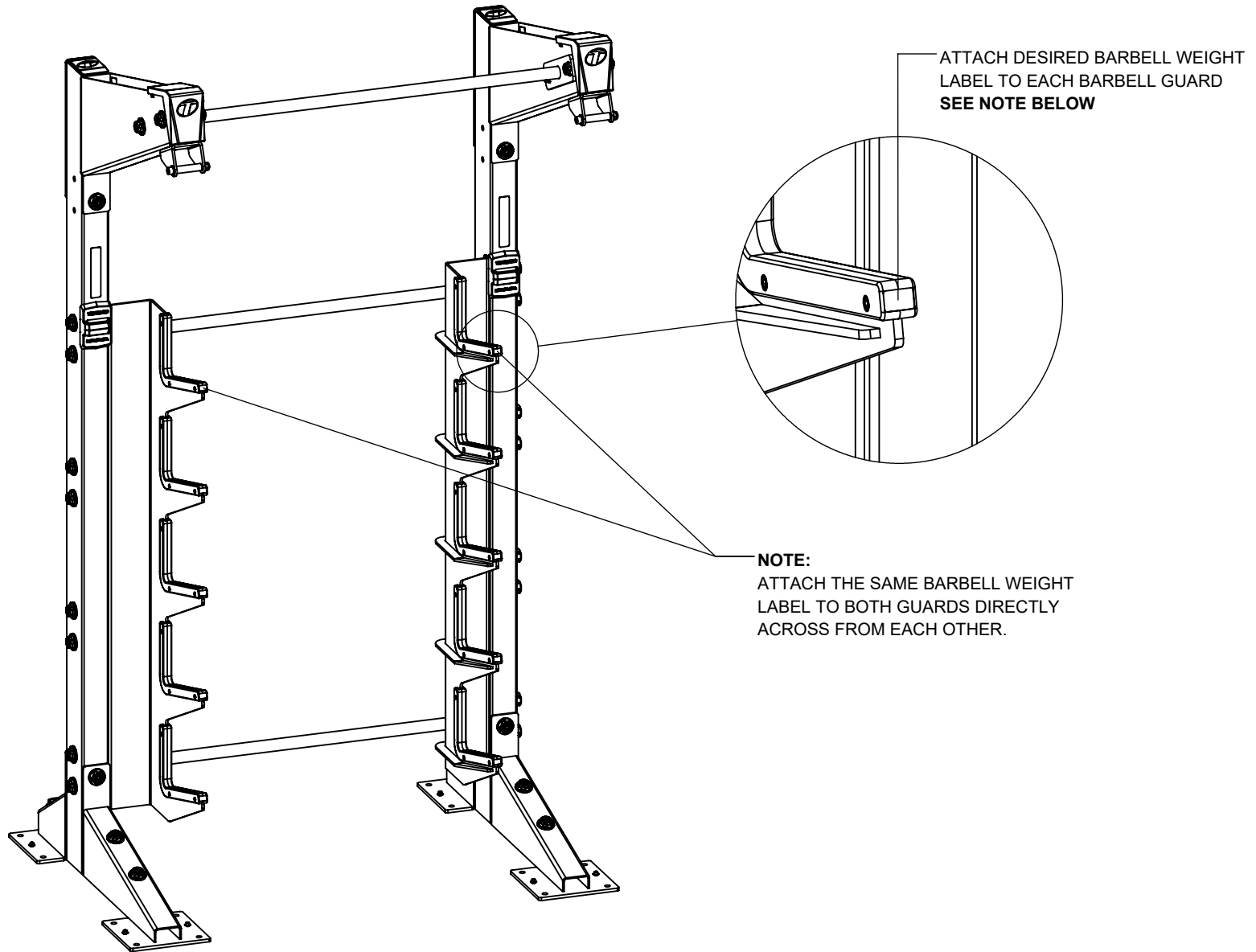

### **NOTE:**

If you are a professional contractor installing this system for a facility, leave these labels and instruction with manager or inquire what label to attach to each barbell guard.

**4' 2 SIDED X 10 BARBELL STORAGE MODULE**

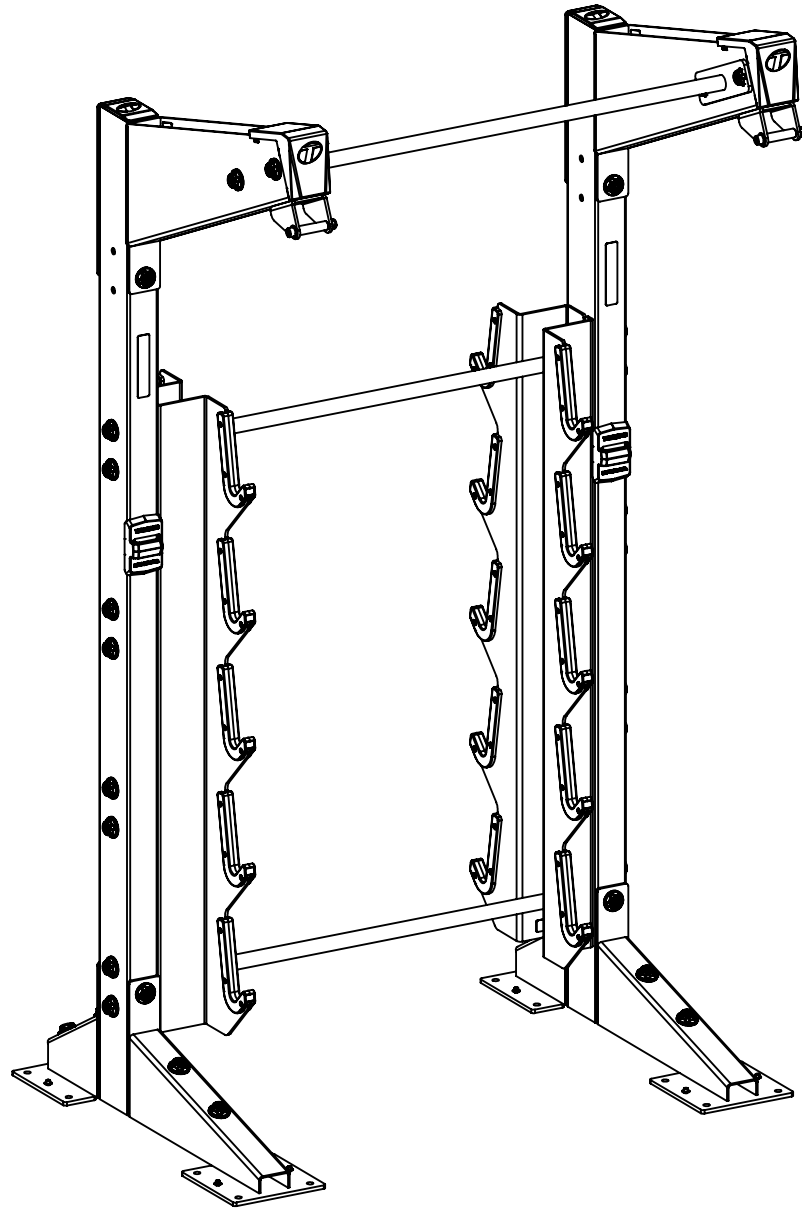

# 4' 2 SIDED X 10 BARBELL STORAGE MODULE (WITHOUT CONNECTOR)

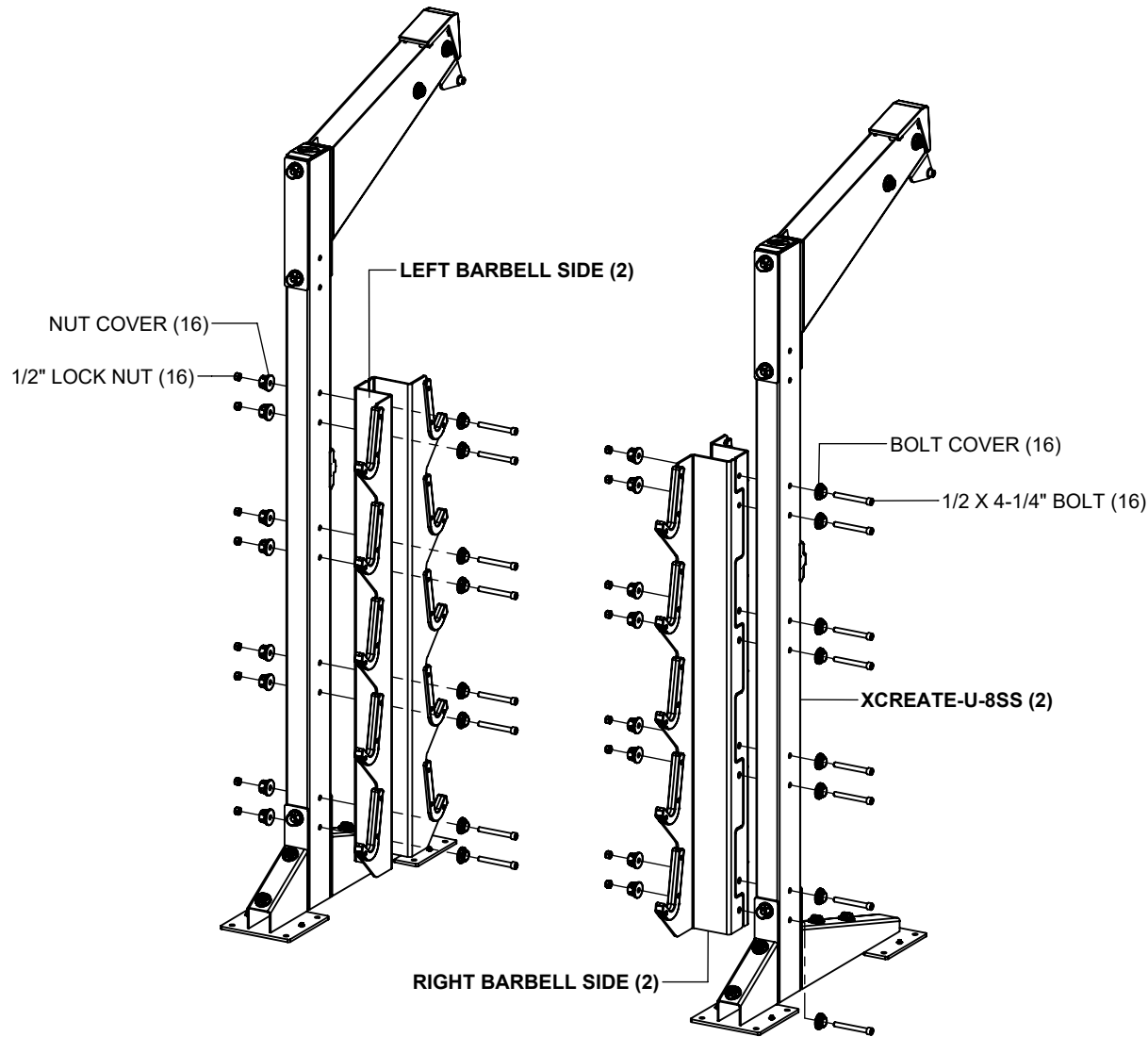

## NOTES:

If more modules will be assembled, do not tighten bolts at this time.  
If this is the only module being assembled, then **SECURELY** tighten all bolts in this step and previous steps.

The **XCREATE-U-7SS** is assembled the exact same way.

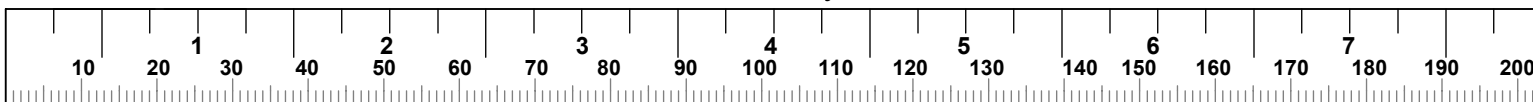

# 4' 2 SIDED X 10 BARBELL STORAGE MODULE (WITH CONNECTOR)

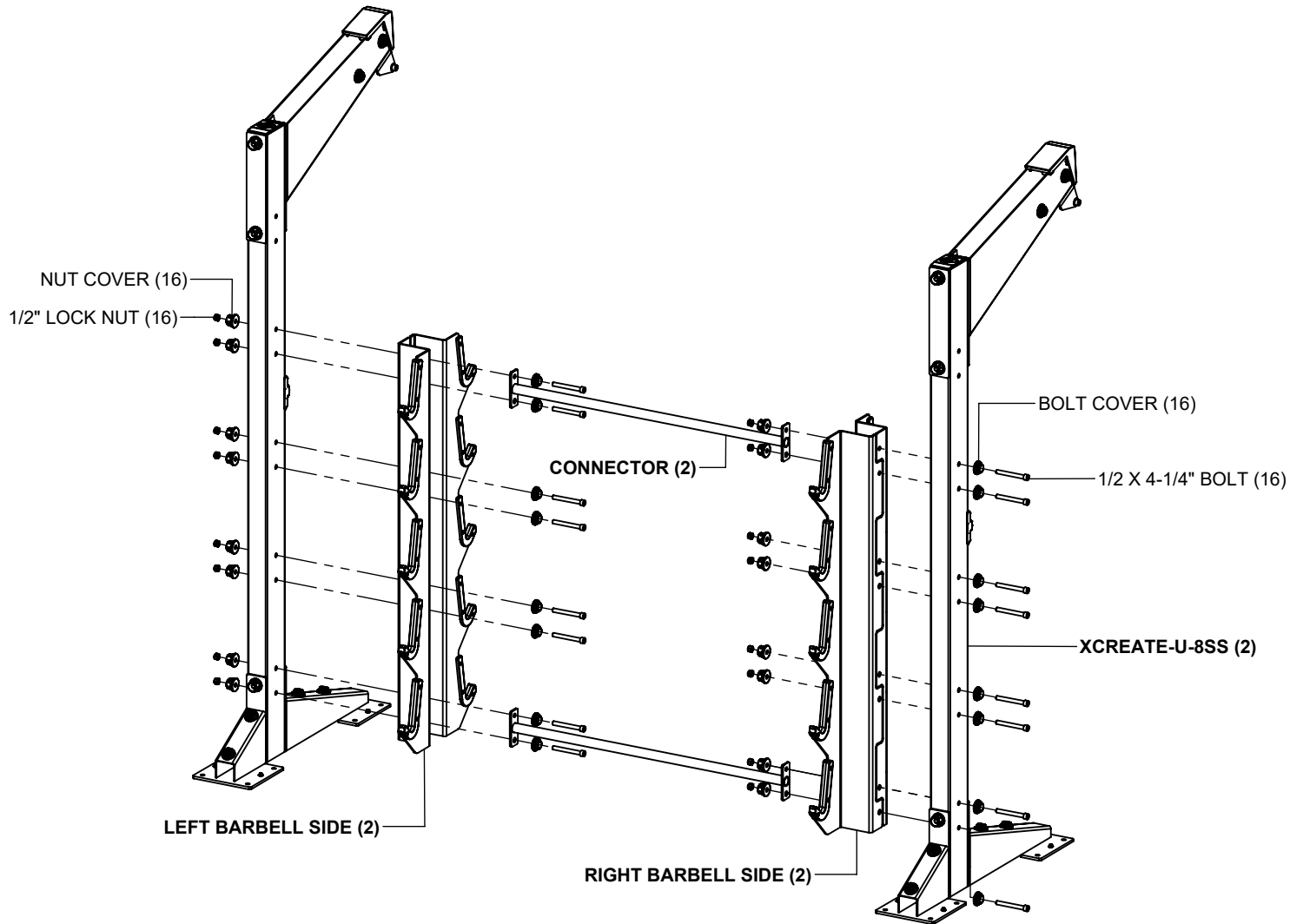

## NOTES:

If more modules will be assembled, do not tighten bolts at this time.  
If this is the only module being assembled, then **SECURELY** tighten all bolts in this step and previous steps.

The **XCREATE-U-7SS** is assembled the exact same way.

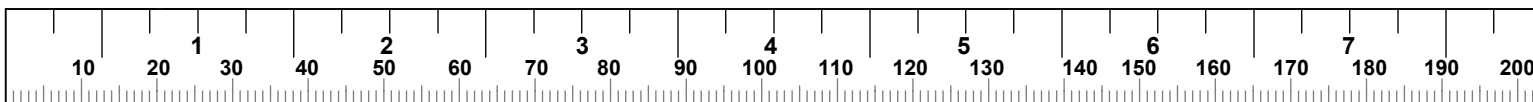

## 4' 2 SIDED X 10 BARBELL STORAGE MODULE

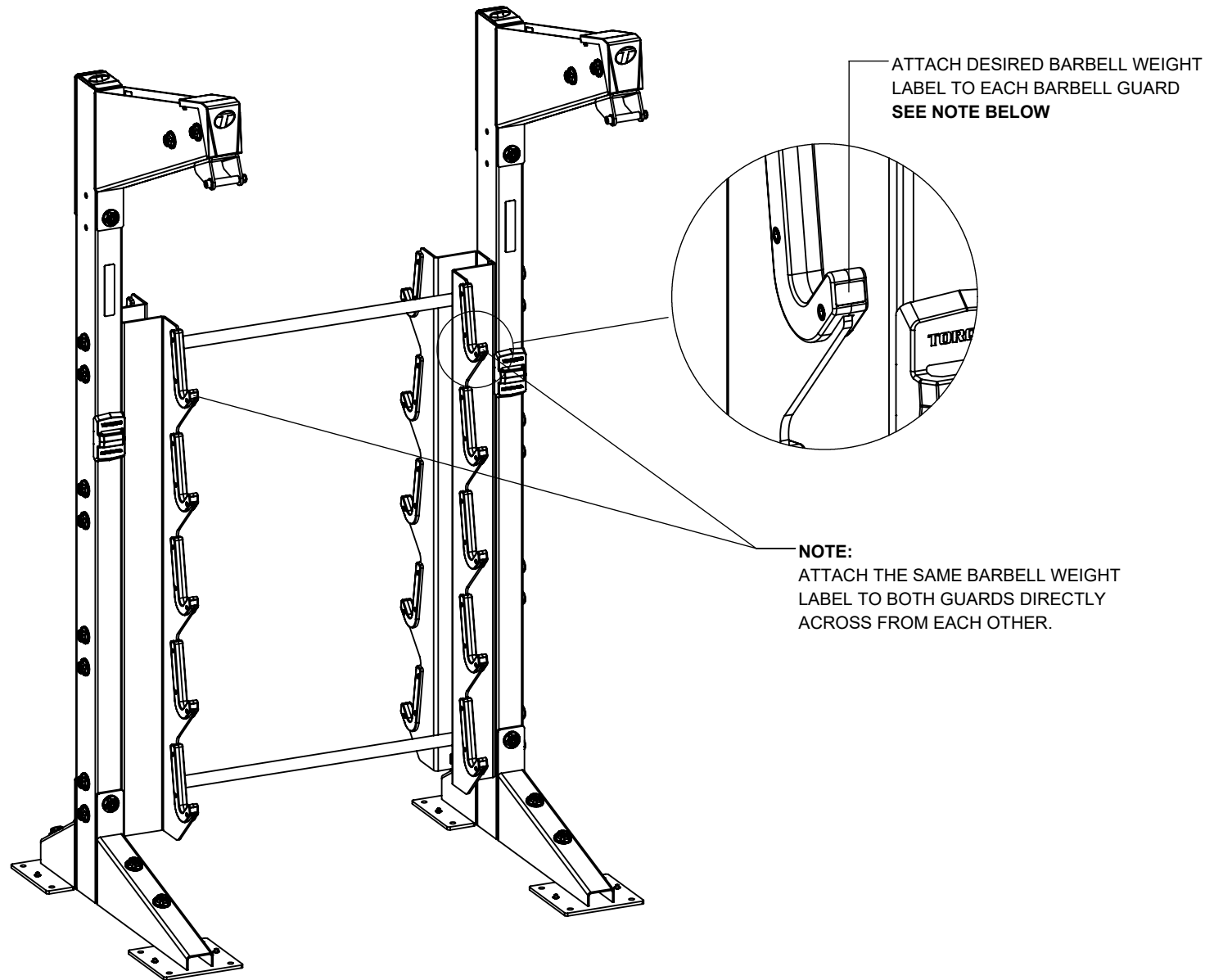

### **NOTE:**

If you are a professional contractor installing this system for a facility, leave these labels and instruction with manager or inquire what label to attach to each barbell guard.



**4' 2 SIDED X 20 BARBELL STORAGE MODULE**

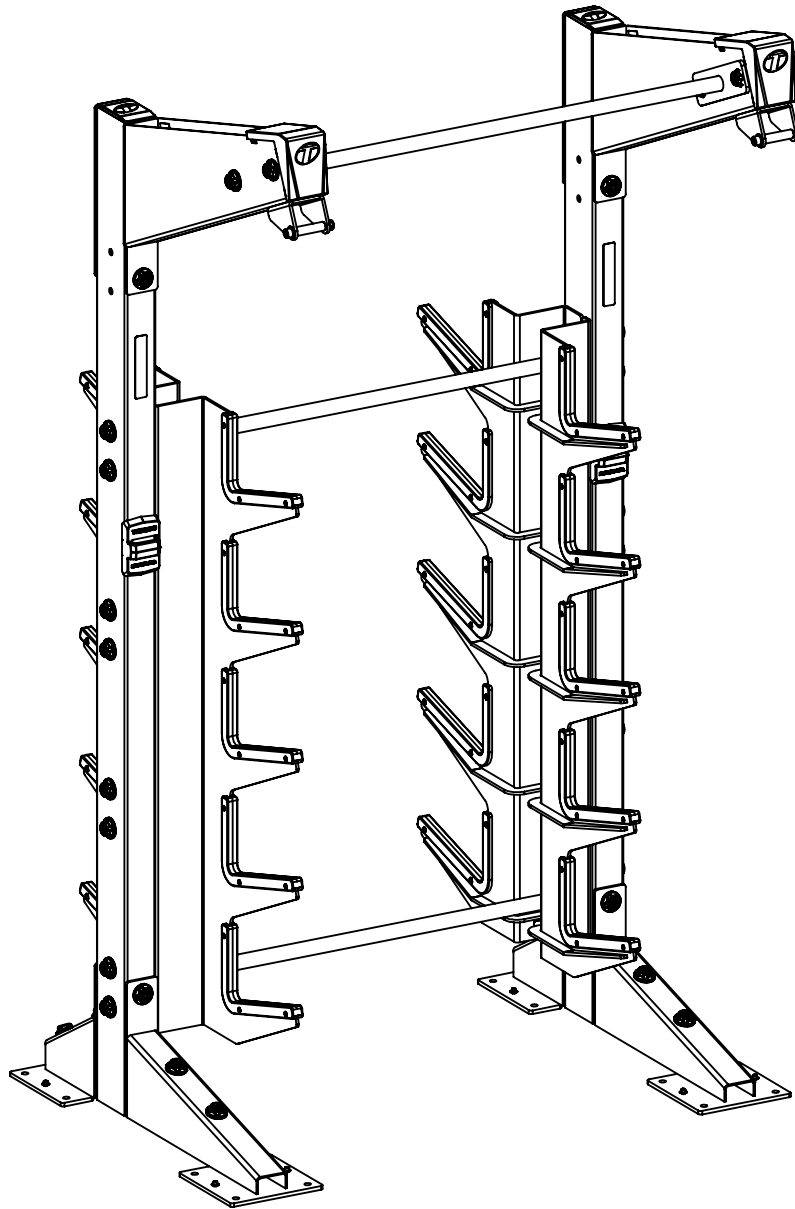

**4' 2 SIDED X 20 BARBELL STORAGE MODULE  
(WITHOUT CONNECTOR)**

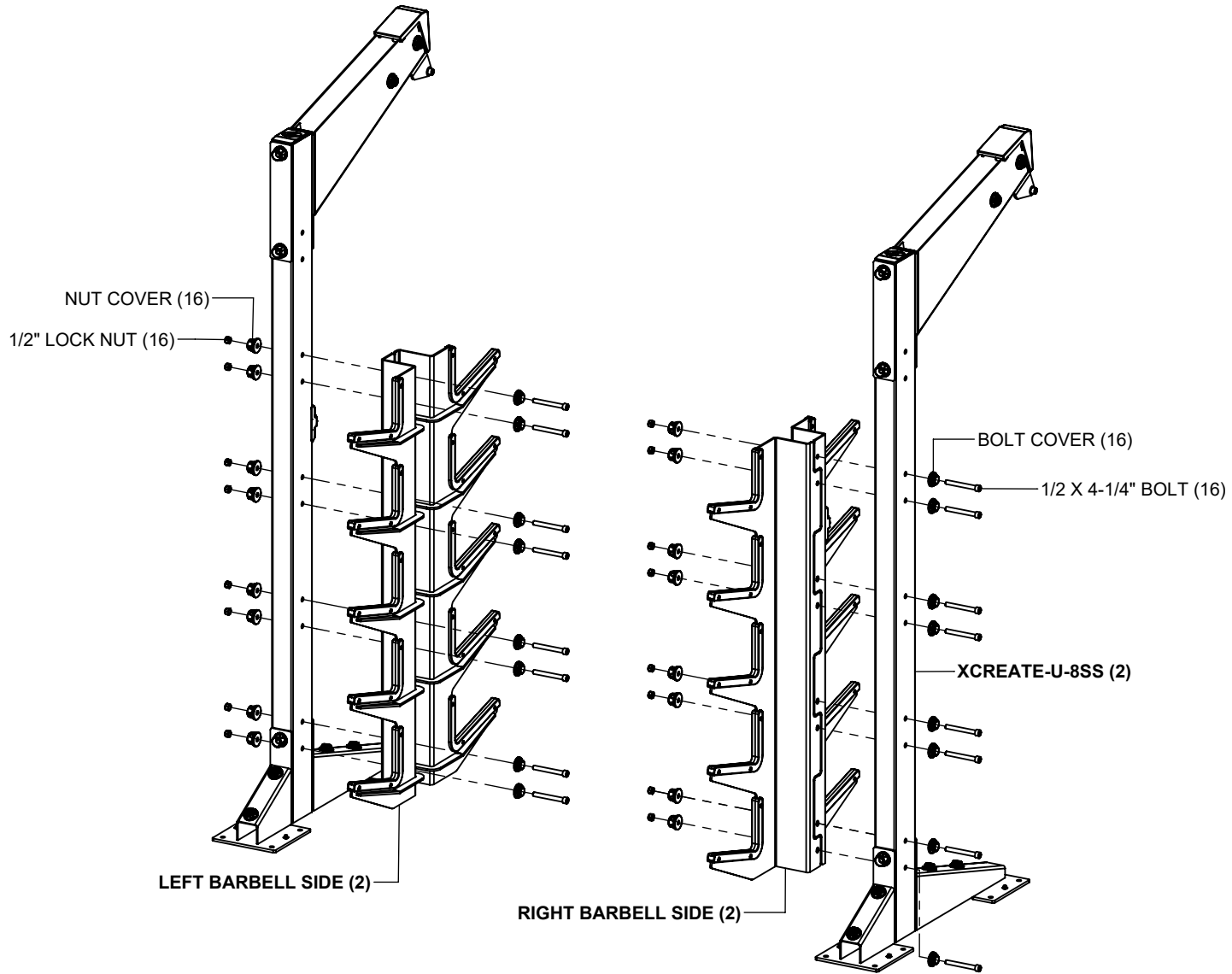

**NOTES:**

If more modules will be assembled, do not tighten bolts at this time.  
If this is the only module being assembled, then **SECURELY** tighten all bolts in this step and previous steps.

The **XCREATE-U-7SS** is assembled the exact same way.

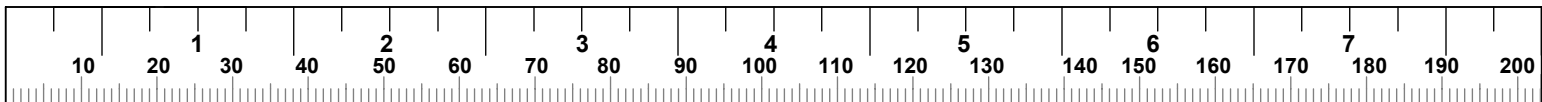

**4' 2 SIDED X 20 BARBELL STORAGE MODULE  
(WITH CONNECTOR)**

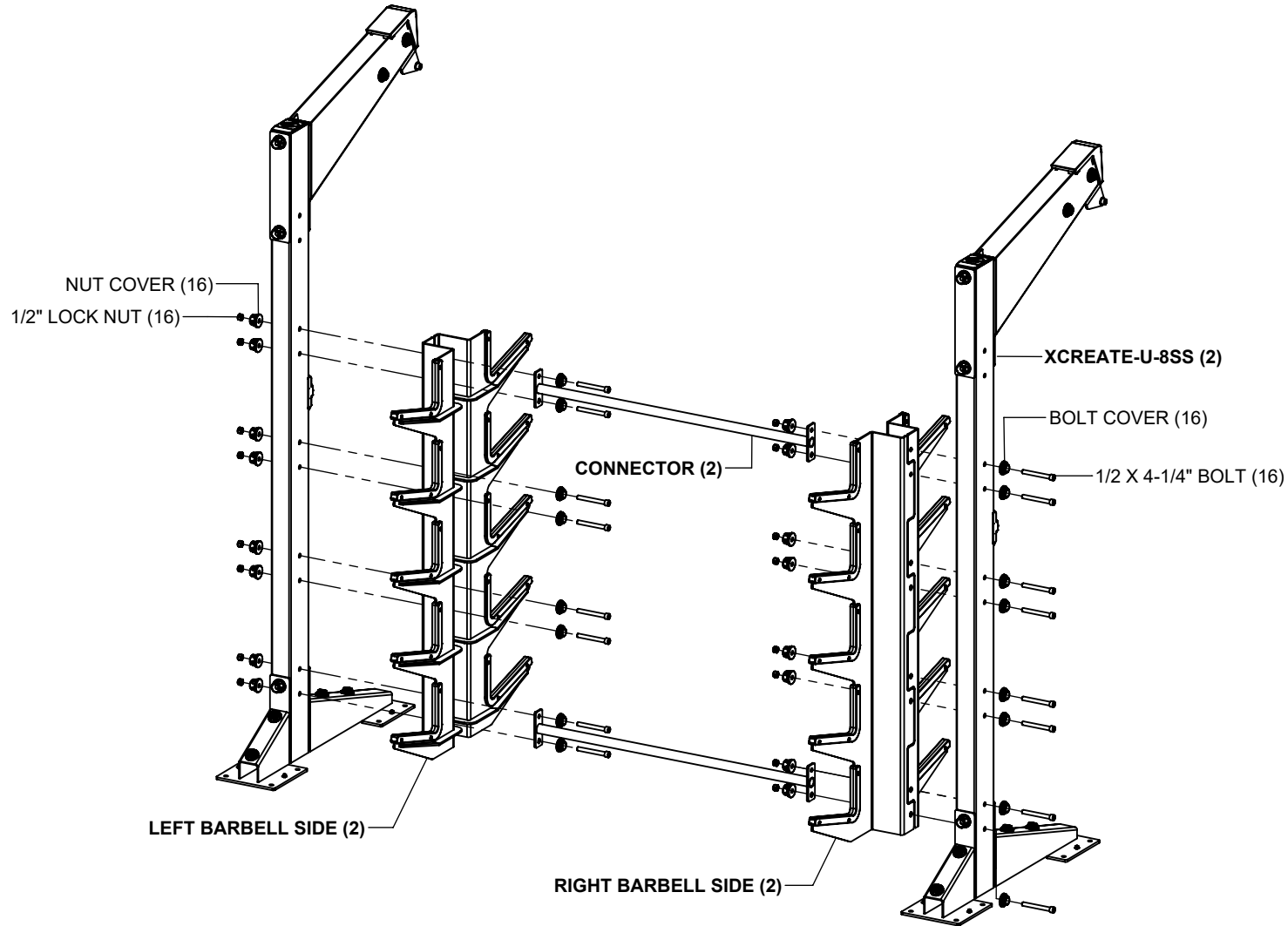

**NOTES:**

If more modules will be assembled, do not tighten bolts at this time.  
If this is the only module being assembled, then **SECURELY** tighten all bolts in this step and previous steps.

The **XCREATE-U-7SS** is assembled the exact same way.

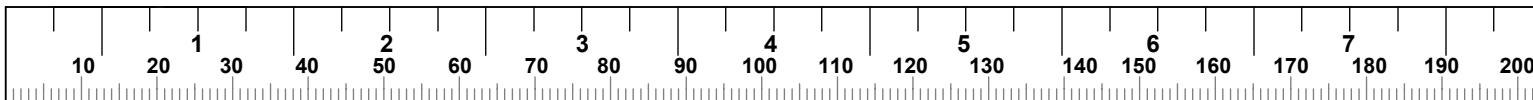

## 4' 2 SIDED X 10 BARBELL STORAGE MODULE

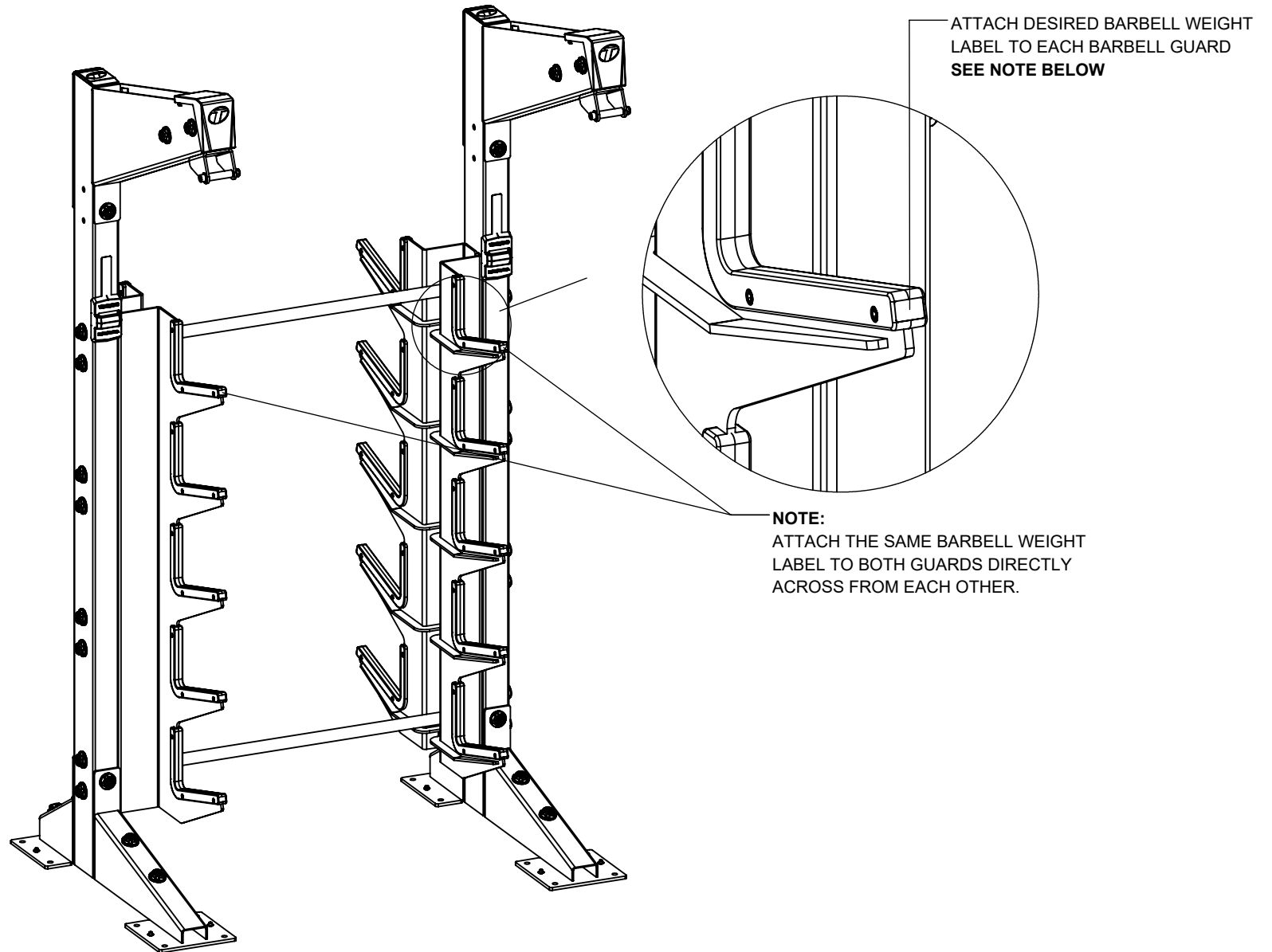

### **NOTE:**

If you are a professional contractor installing this system for a facility, leave these labels and instruction with manager or inquire what label to attach to each barbell guard.

**4' MONITOR MOUNT & STORAGE MODULE**

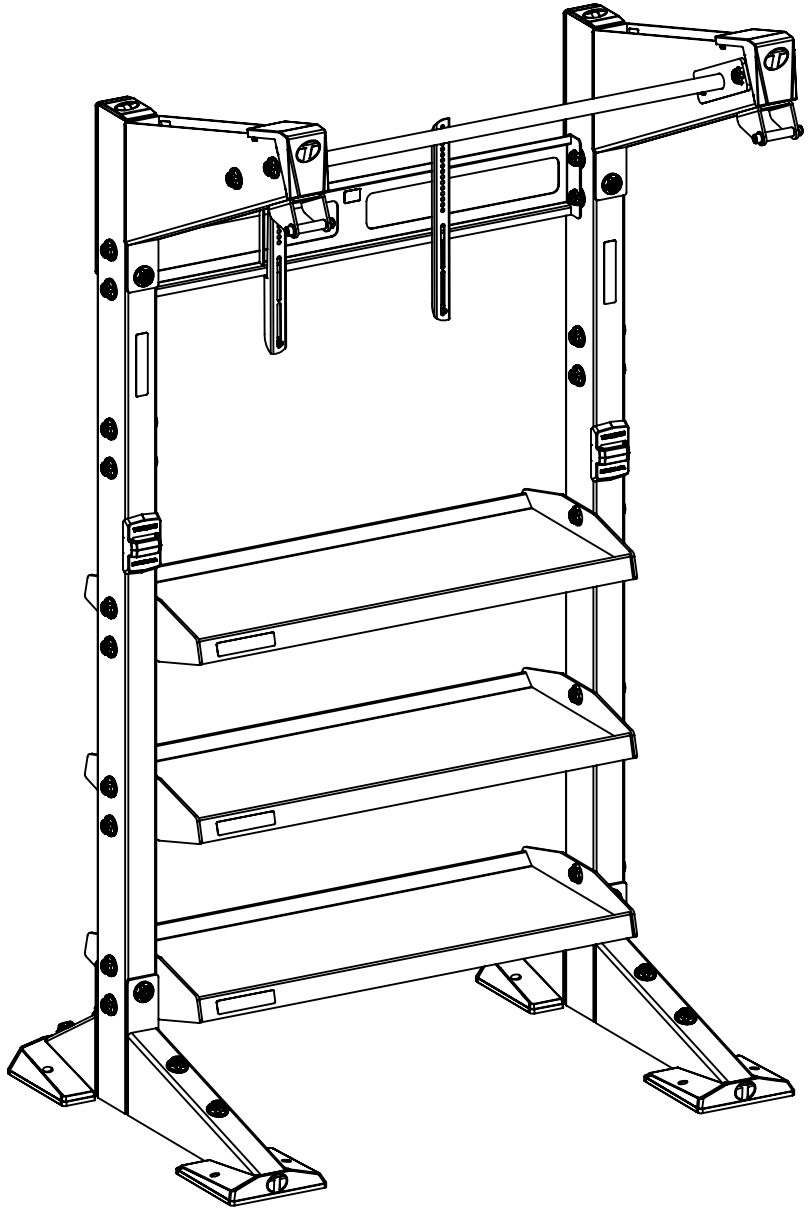

**STANDARD CONFIGURATION**

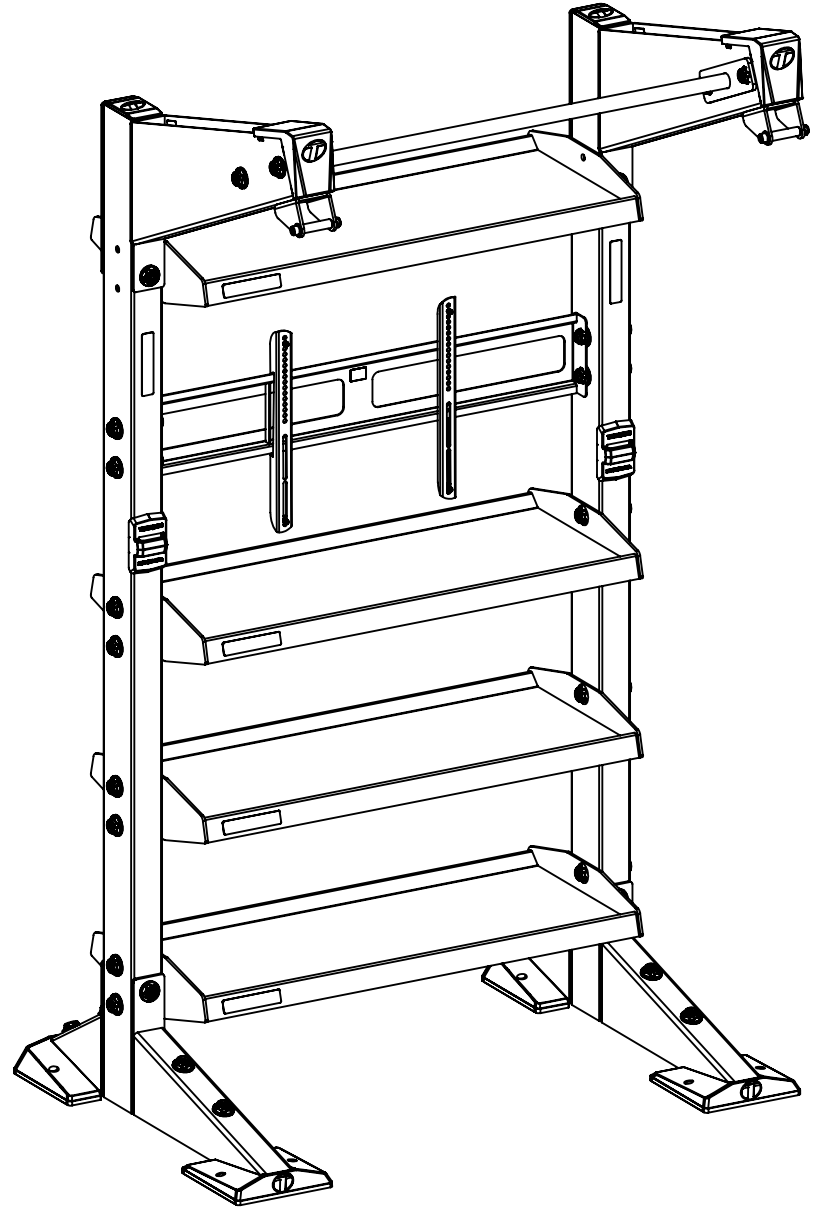

**OPTIONAL CONFIGURATION**

# 4' MONITOR MOUNT & STORAGE MODULE

## STEP 1A

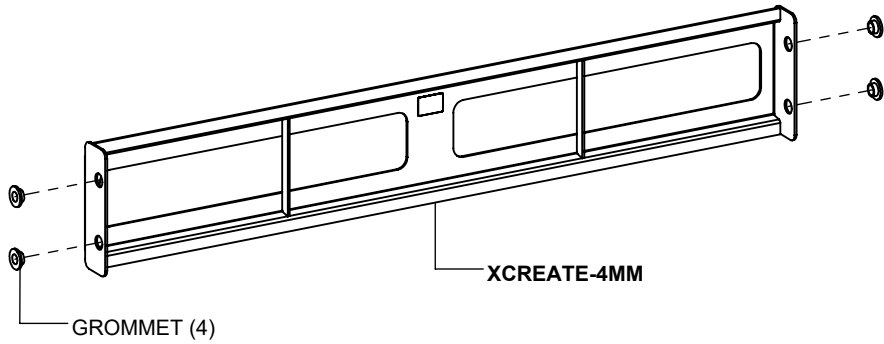

## STEP 1B

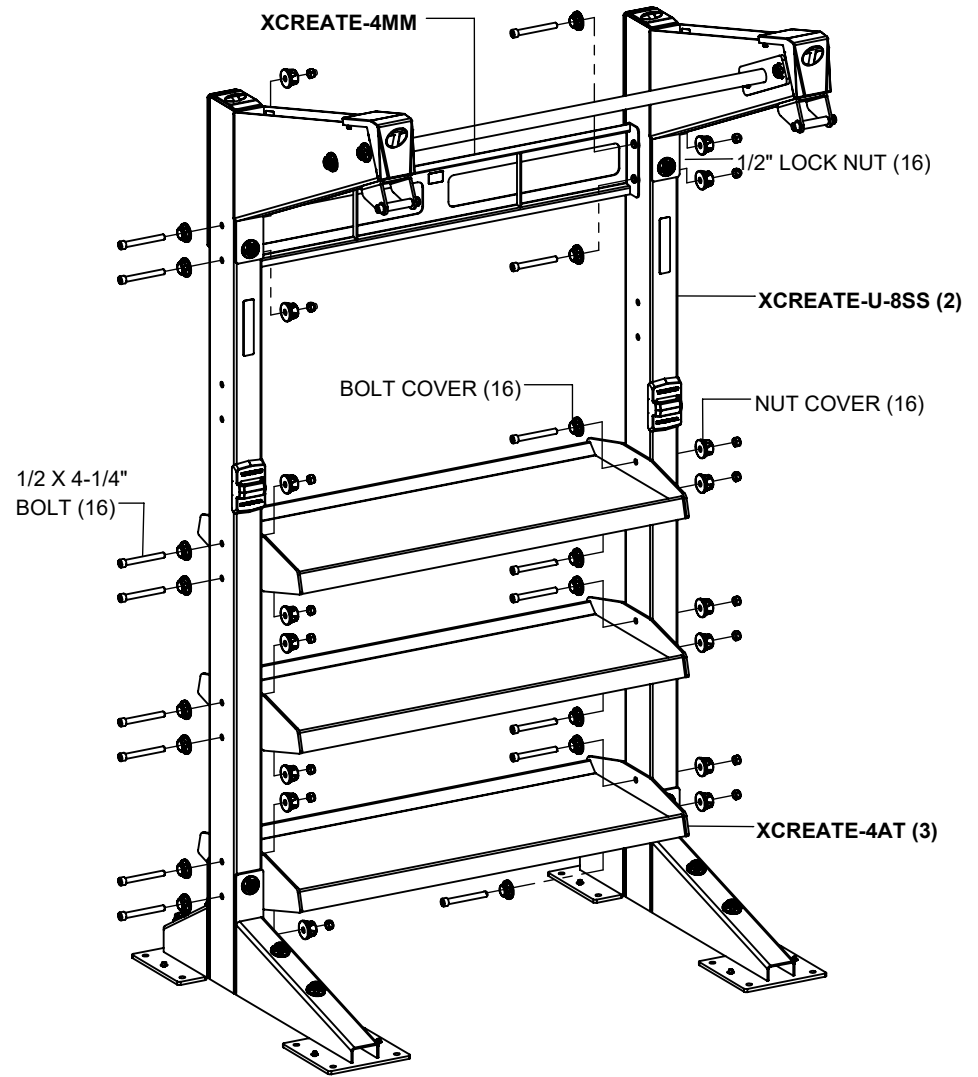

### NOTES:

If more modules will be assembled, do not tighten bolts at this time. If this is the only module being assembled, then **SECURELY** tighten all bolts in this step and previous steps.

The **XCREATE-U-7SS** is assembled the exact same way.

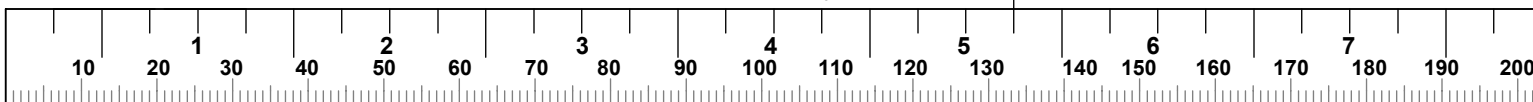

# 4' MONITOR MOUNT & STORAGE MODULE

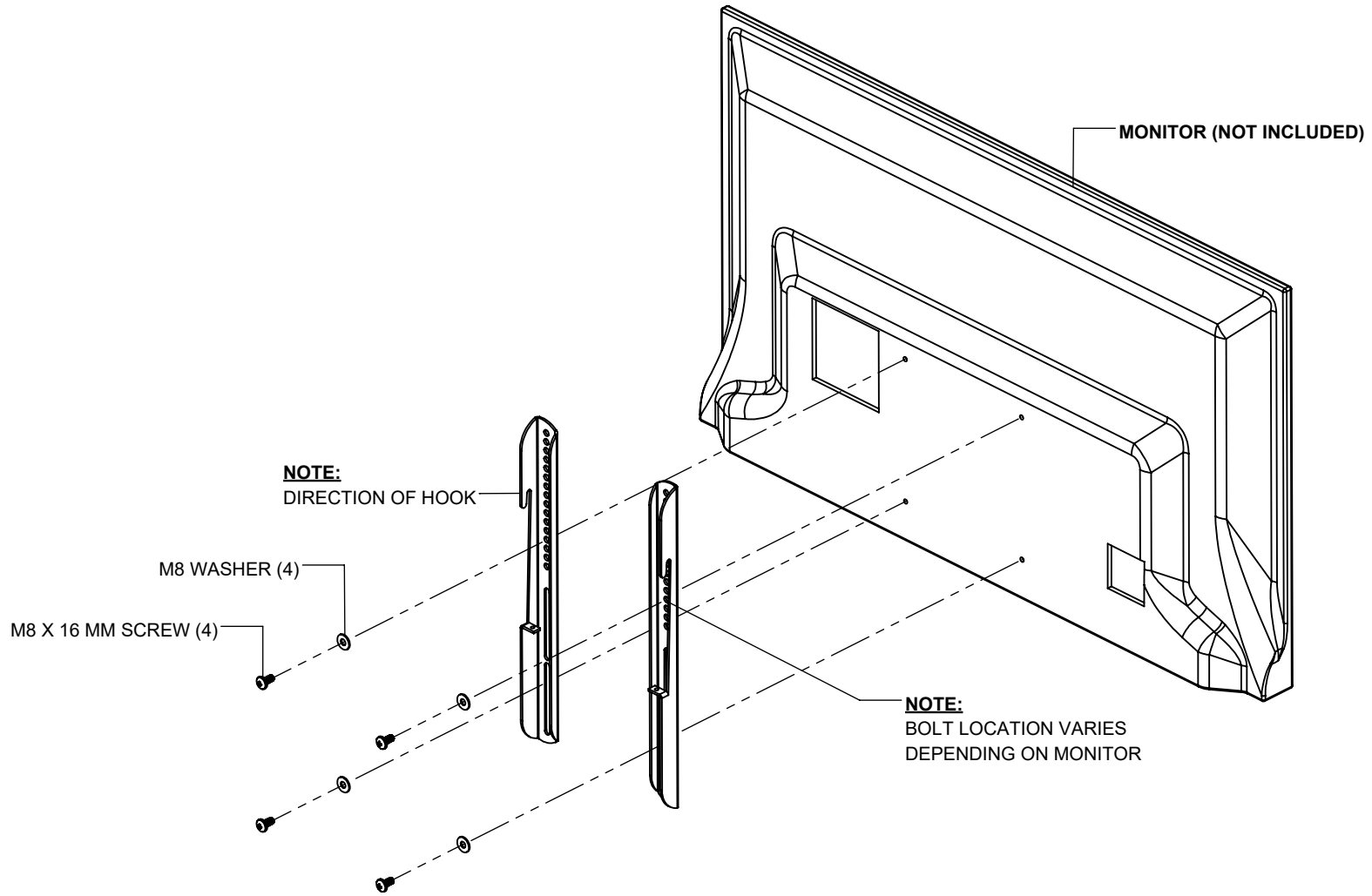

## **NOTE:**

**SECURELY** tighten all connections in this step.

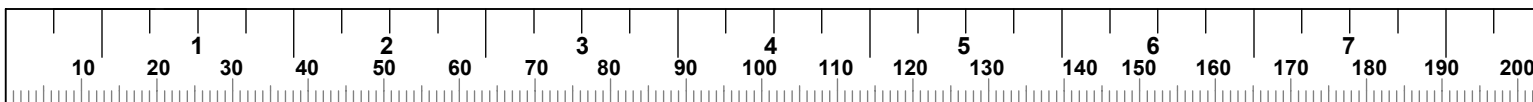

# 4' MONITOR MOUNT & STORAGE MODULE

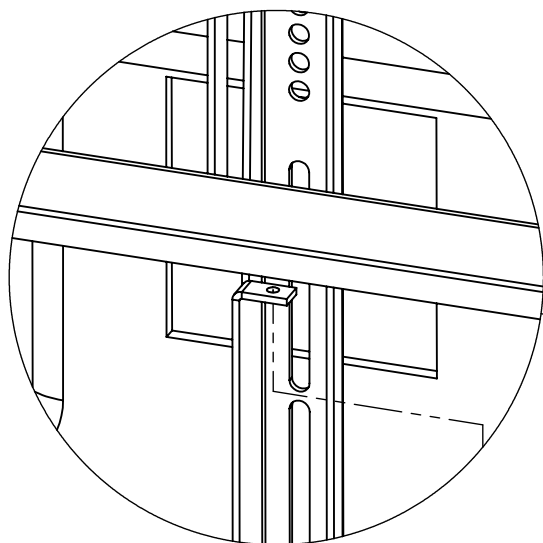

**NOTE:**  
CENTER MONITOR BEFORE TIGHTENING

M6 x 35 MM BOLT(2)

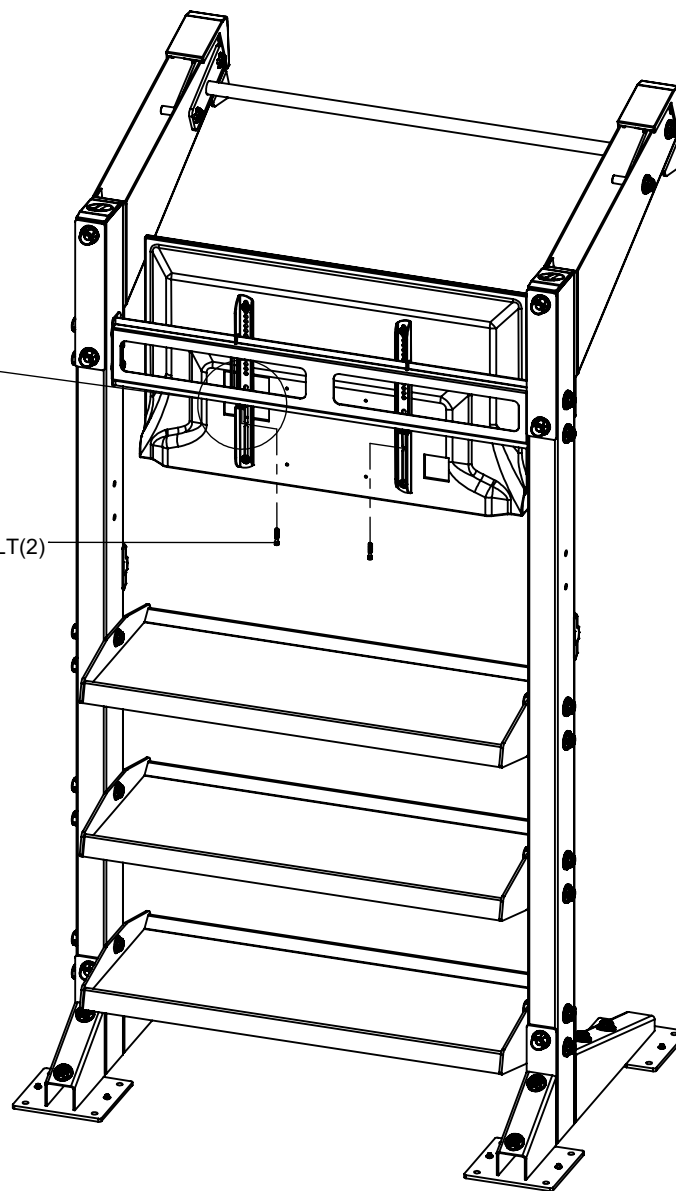

## **NOTE:**

**SECURELY** tighten all connections in this step.

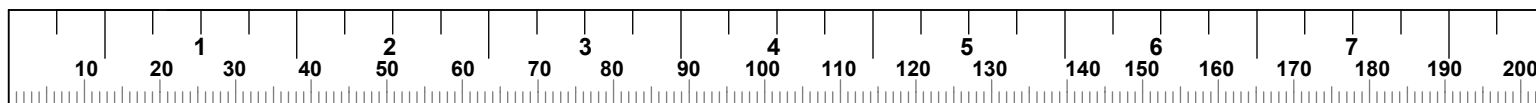



**4' CUSTOM SIGN & HANGING STORAGE MODULE**

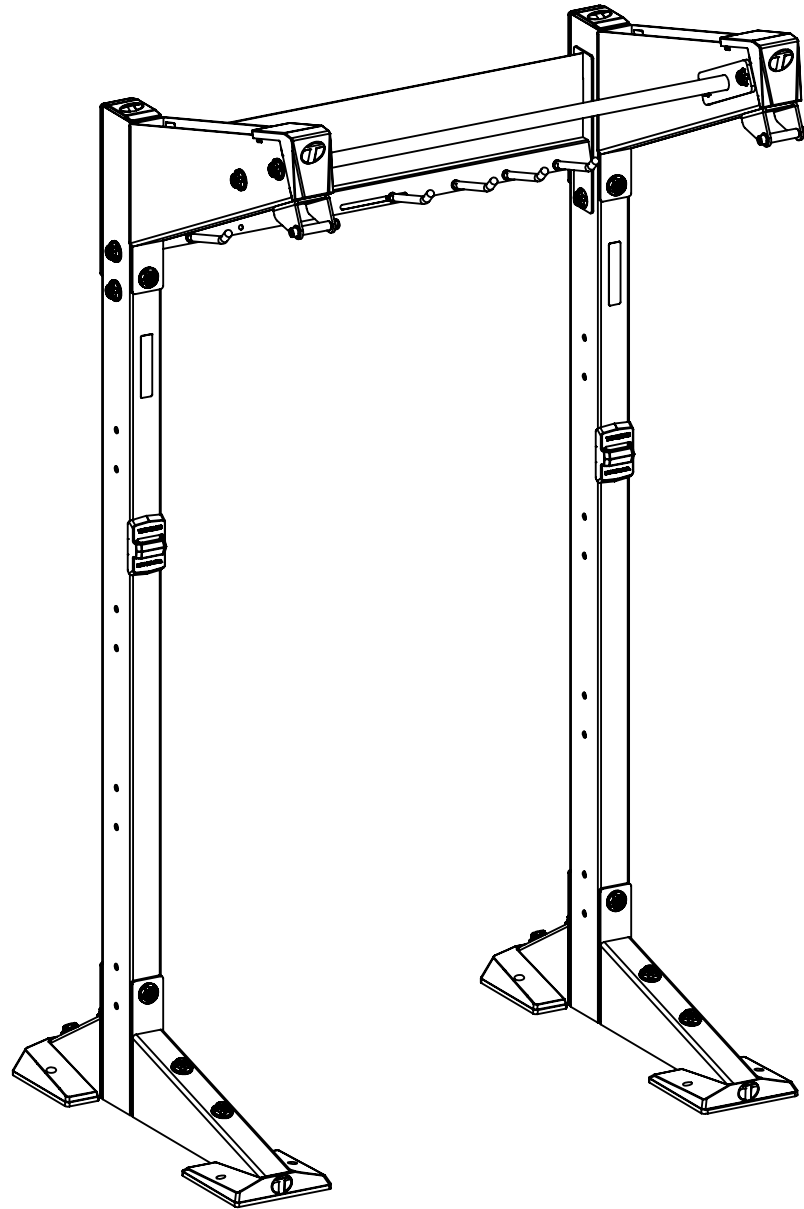

## 4' CUSTOM SIGN & HANGING STORAGE MODULE

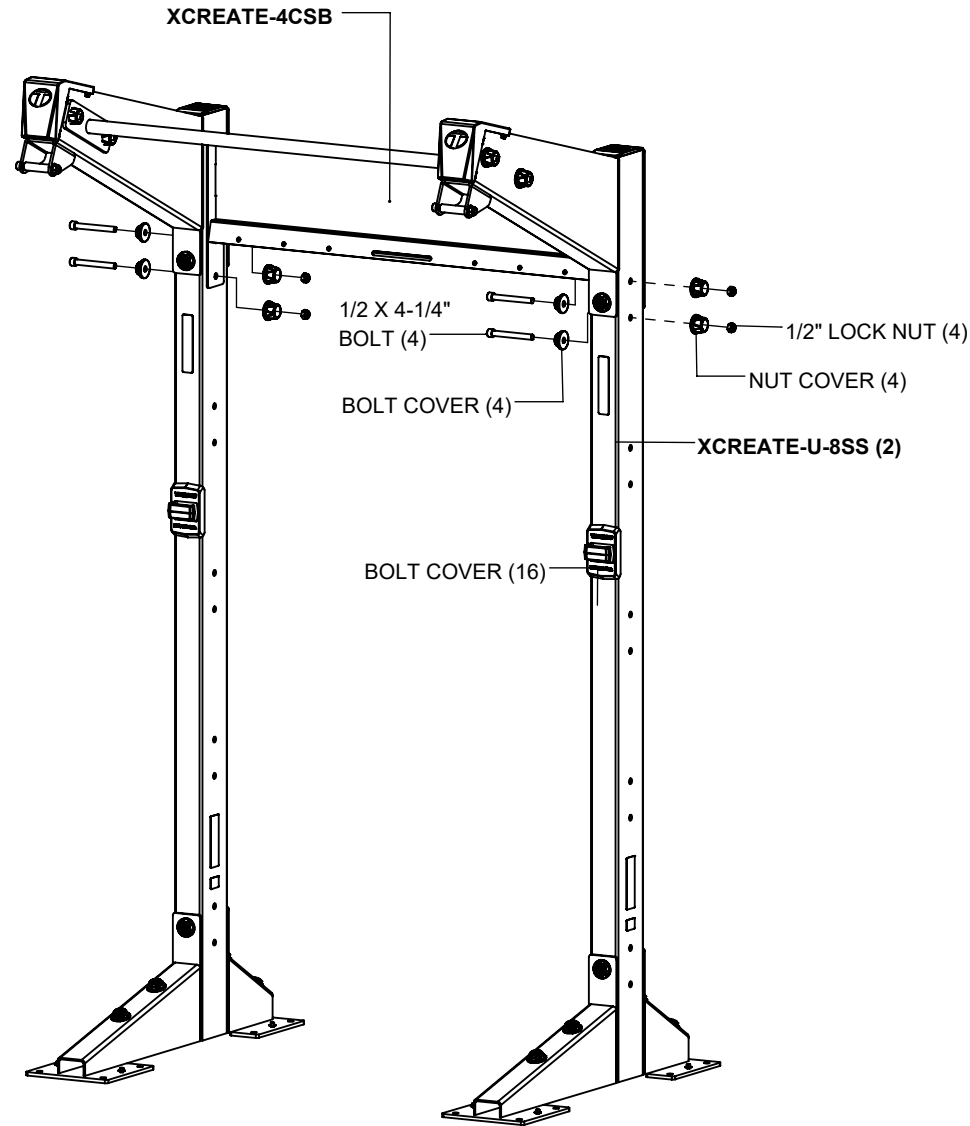

### NOTES:

If more modules will be assembled, do not tighten bolts at this time.  
If this is the only module being assembled, then **SECURELY** tighten all bolts in this step and previous steps.

The **XCREATE-U-7SS** is assembled the exact same way.

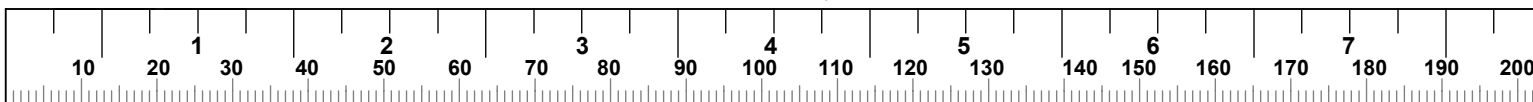

# MAT STORAGE AND ACCESSORY PINS

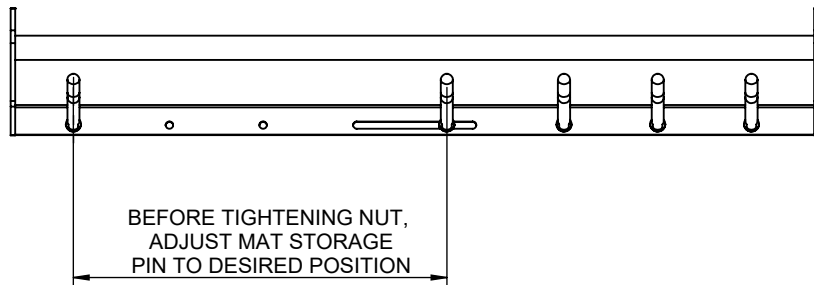
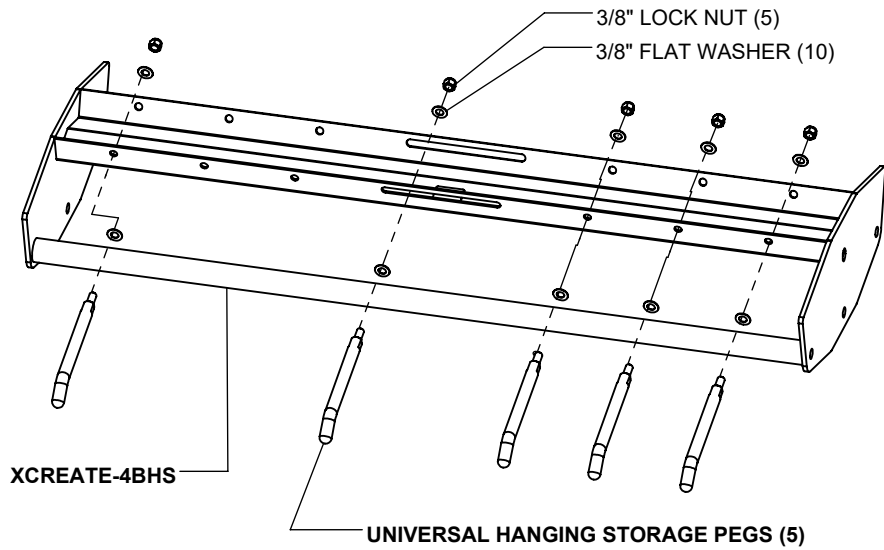

## NOTE:

For the purpose of illustration the XCREATE-4BHS is shown. The XCREATE-4BHS, XCREATE-4CSB and XCREATE-6BHS can be assembled the same way.

**SECURELY** tighten all connections in this step.

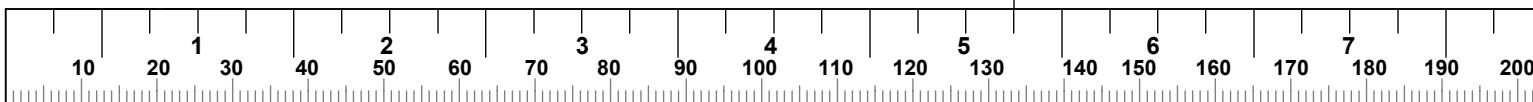
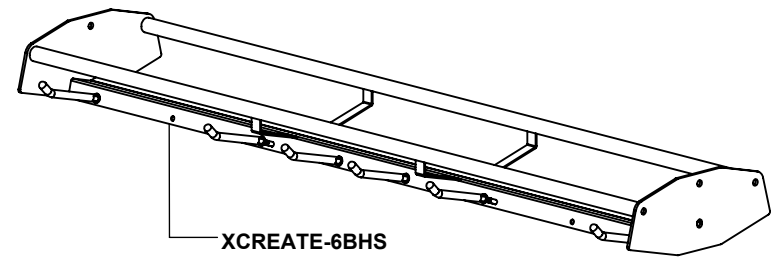
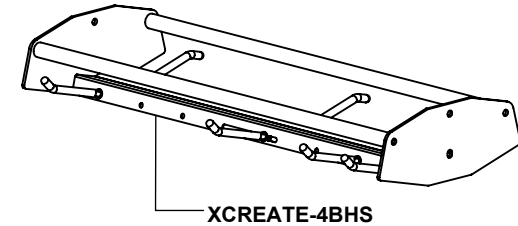
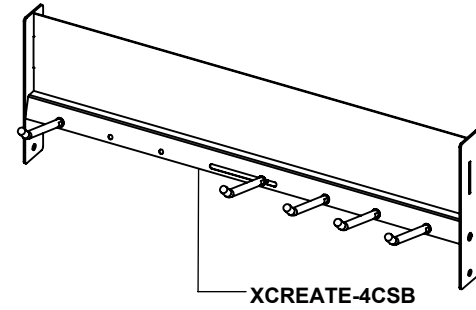

## ACCESSORY TRAY LABELS

ATTACH DESIRED  
LABEL TO EACH  
ACCESSORY TRAY  
SEE NOTE BELOW

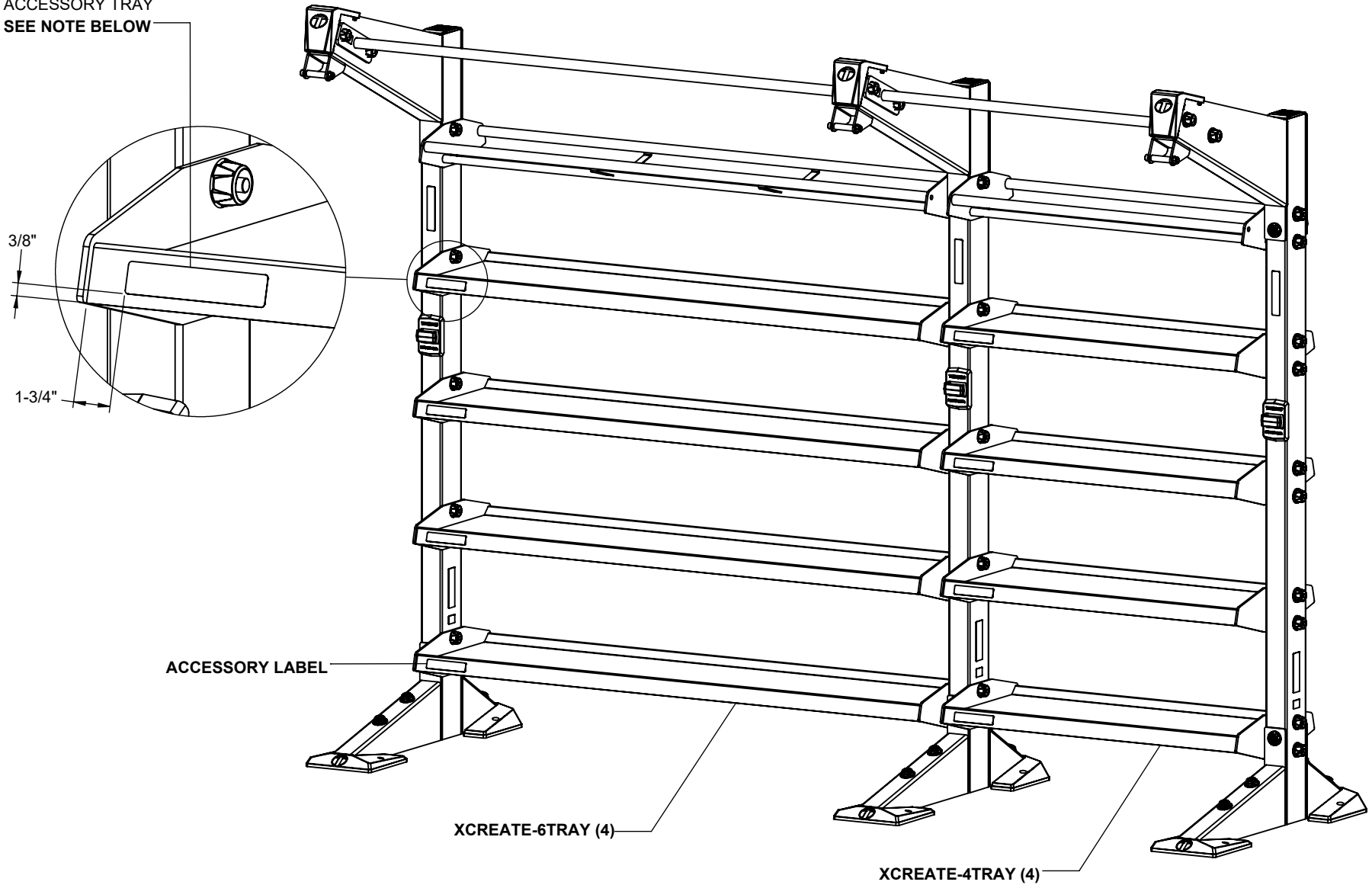

### **NOTE:**

If you are a professional contractor installing this system for a facility, leave these labels and instruction with manager or inquire what label to attach to each accessory tray.

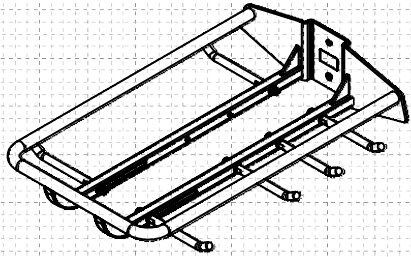

**XCREATE-BHSE**  
BALL AND HANGING  
STORAGE EXTENSION

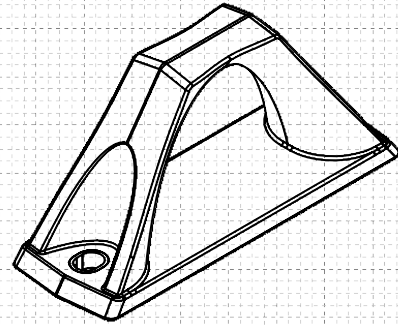

**XRACK-BRA**  
BATTLE ROPE ANCHOR

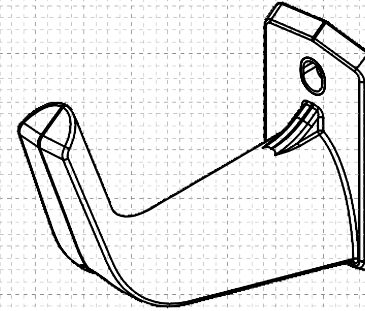

**XCREATE-HSH**  
HANGING STORAGE HOOK

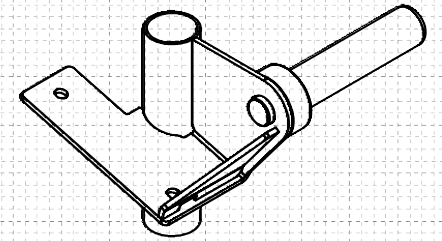

**XCREATE-DP**  
DOUBLE PLAY

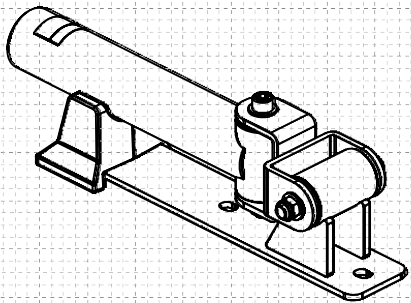

**XHMGR**  
HORIZONTAL MOUNT  
GROUND ROTATIONAL TRAINER

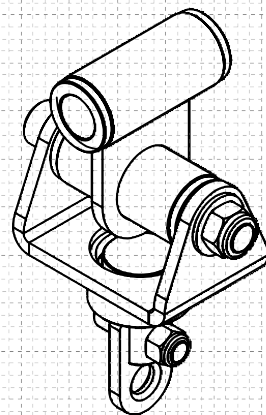

**XCREATE-3DS**  
3 DIMENSIONAL SWIVEL

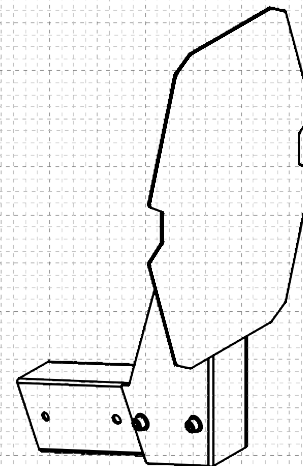

**XCREATE-BT**  
BALL TARGET

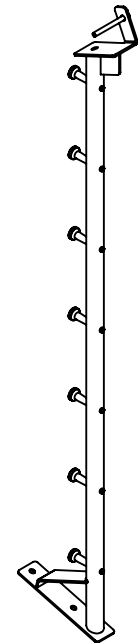

**XCREATE-RBA**  
RESISTANCE BAND ANCHOR

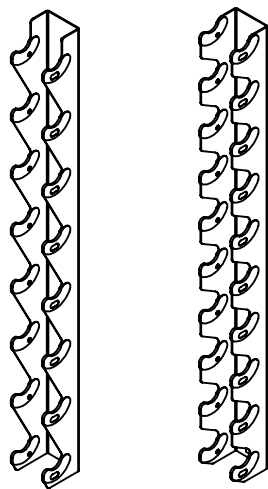

**XCREATE-VDS4 / VDS5**  
VERTICAL DUMBBELL  
STORAGE

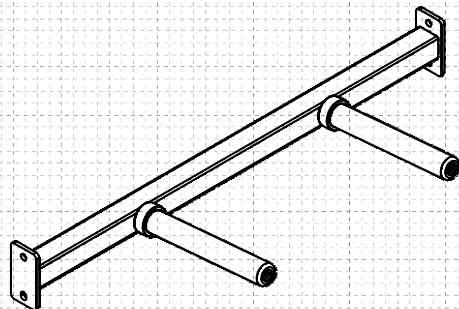

**XCREATE-4SSHWS**  
4' SINGLE SIDE HORIZONTAL  
WEIGHT STORAGE

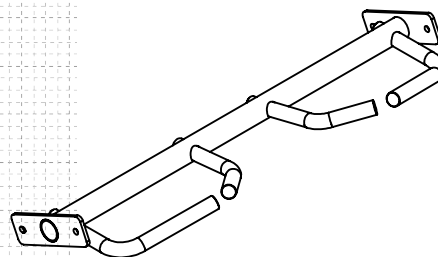

**XCREATE-4MGX**  
4' MULTI GRIP CROSS

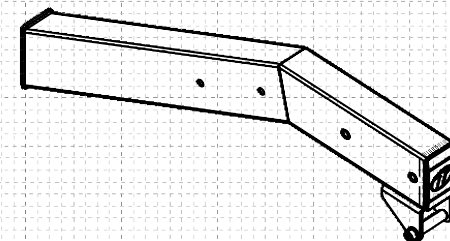

**XCREATE-TBE**  
TOP BOOM EXTENSION



**XCREATE-AA**  
ATTACHMENT ANCHOR

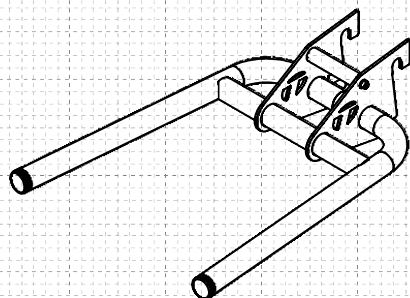

**XCREATE-AAD**  
DIP ATTACHMENT

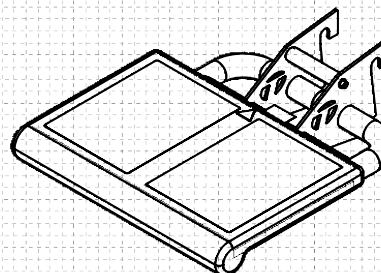

**XCREATE-AAPS**  
PLYO STEP

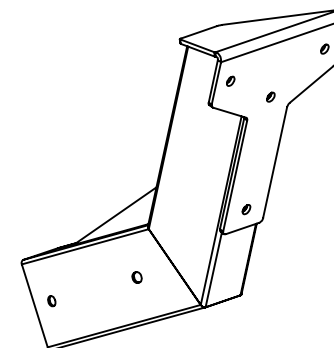

**XCREATE-AE**  
ATTACHMENT EXTENSION

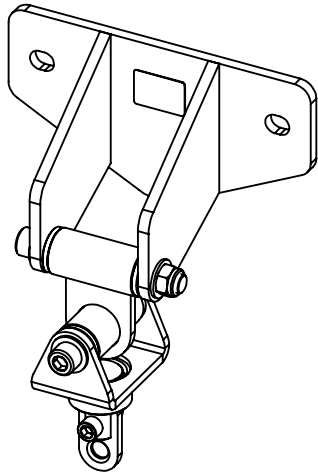

**XCREATE-3DSM**  
3 DIMENSIONAL SWIVEL W/MOUNT

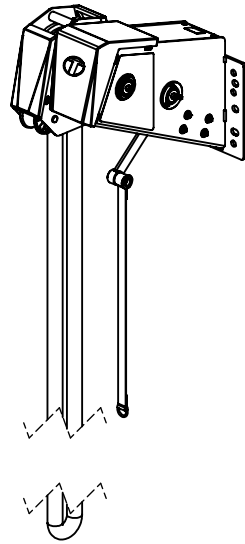

**XERT**  
RELENTLESS ROPE TRAINER

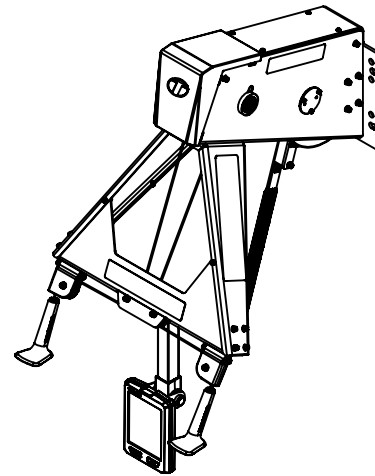

**XRR-SKI**  
RELENTLESS RIPPER

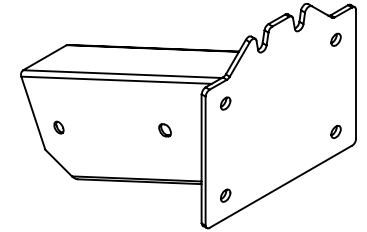

**XCREATE-BMXERT**  
BOOM MOUNT

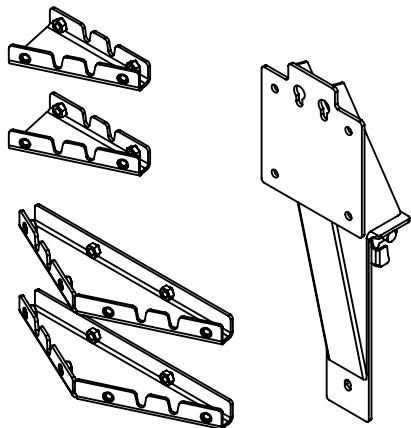

**XCREATE-SAM**  
SIDE ATTACHMENT MOUNT

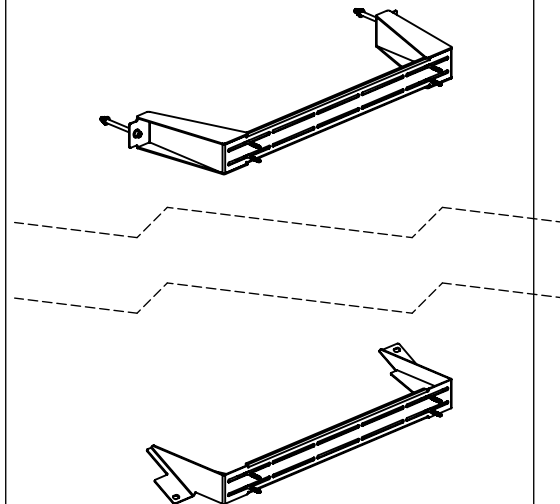

**XCREATE-4WAB**  
4' WALL ANCHOR BRACKET

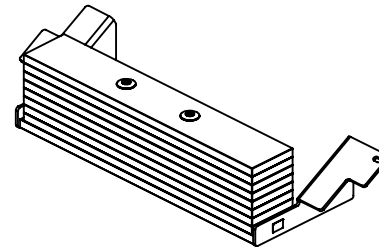

**XCREATE-4CWS/CWP**  
4' COUNTERWEIGHT SUPPORT/  
COUNTERWEIGHT PLATES

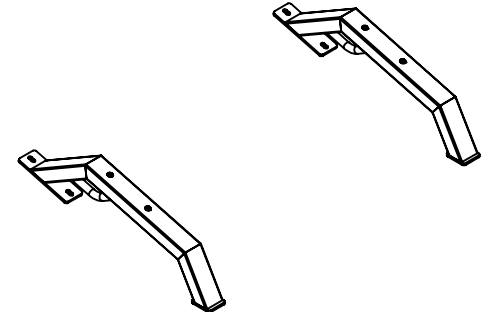

**XCREATE-OR**  
OUTRIGGER

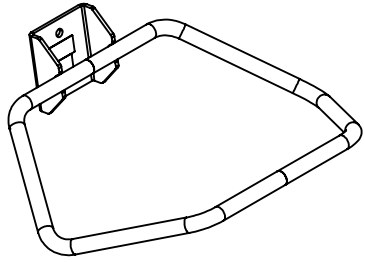

**XCREATE-SA-BOSU**  
BOSU STORAGE ATTACHMENT

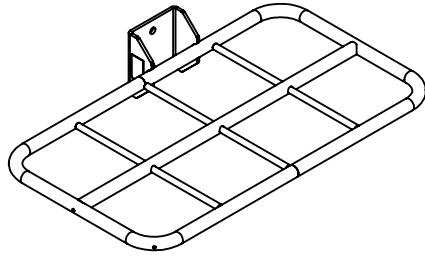

**XCREATE-FRS**  
FOAM ROLLER STORAGE

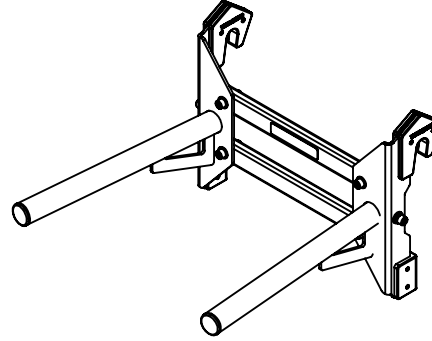

**XCREATE-SBDA**  
STALL BAR DIP ATTACHMENT

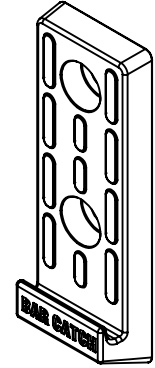

**BCSA**  
BAR CATCH STORAGE  
ATTACHMENT

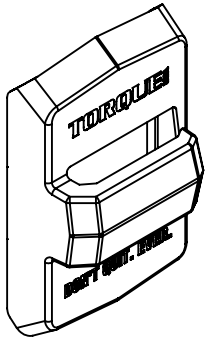

**XCREATE-HMSC**  
SUSPENSION CLIP



**XCREATE-BHSE  
BALL & HANGING  
STORAGE EXTENSION**

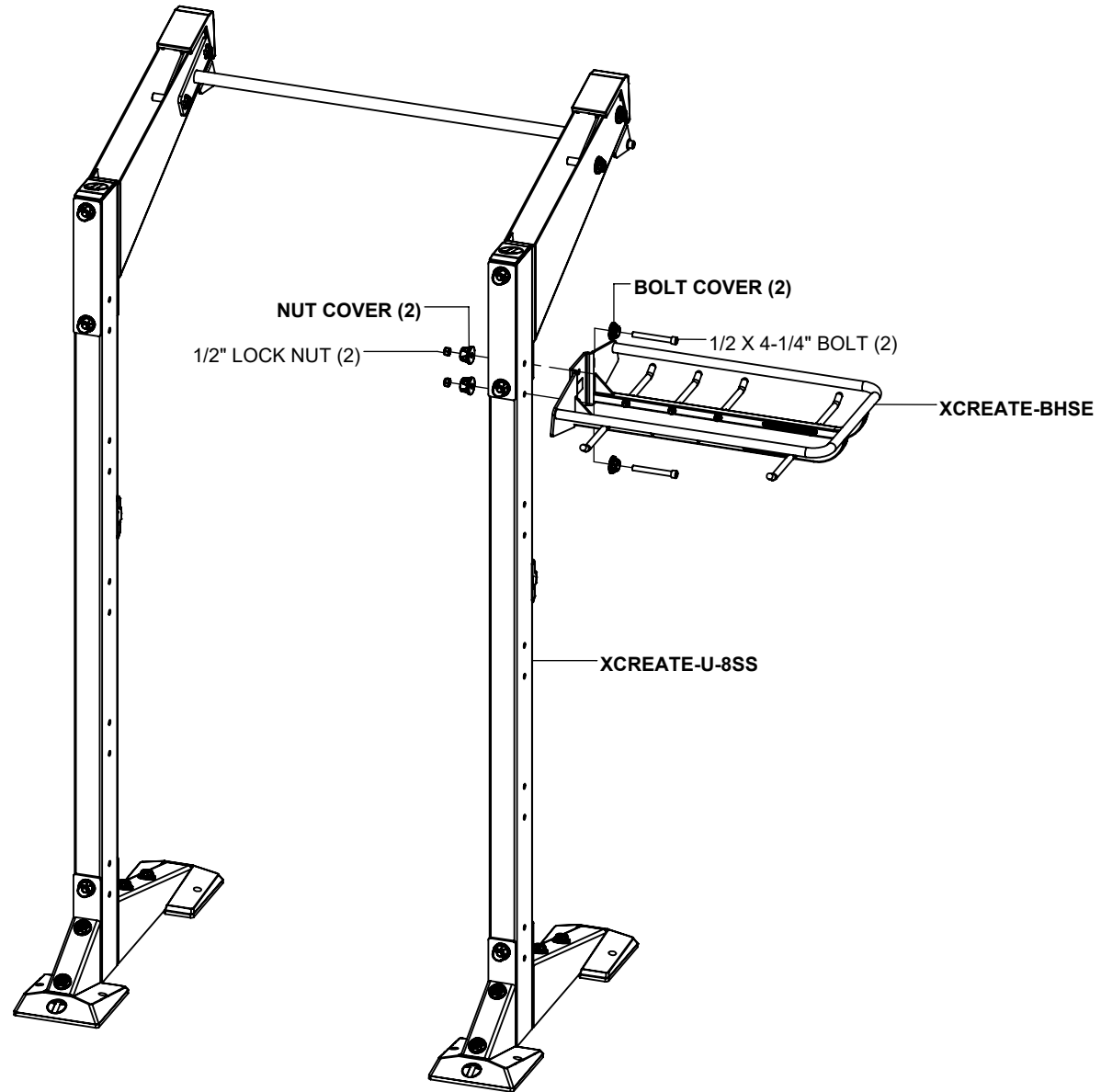

**NOTES:**

**SECURELY** tighten all bolt connections in this step.

The **XCREATE-U-7SS** is assembled the exact same way.

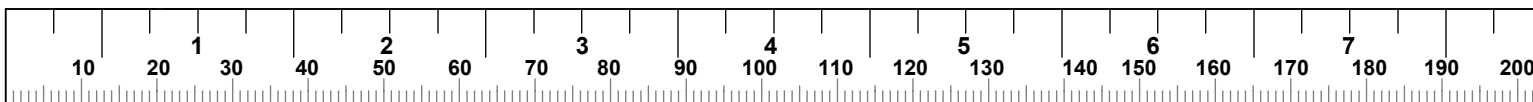

**XRACK-BRA  
BATTLE ROPE ANCHOR**

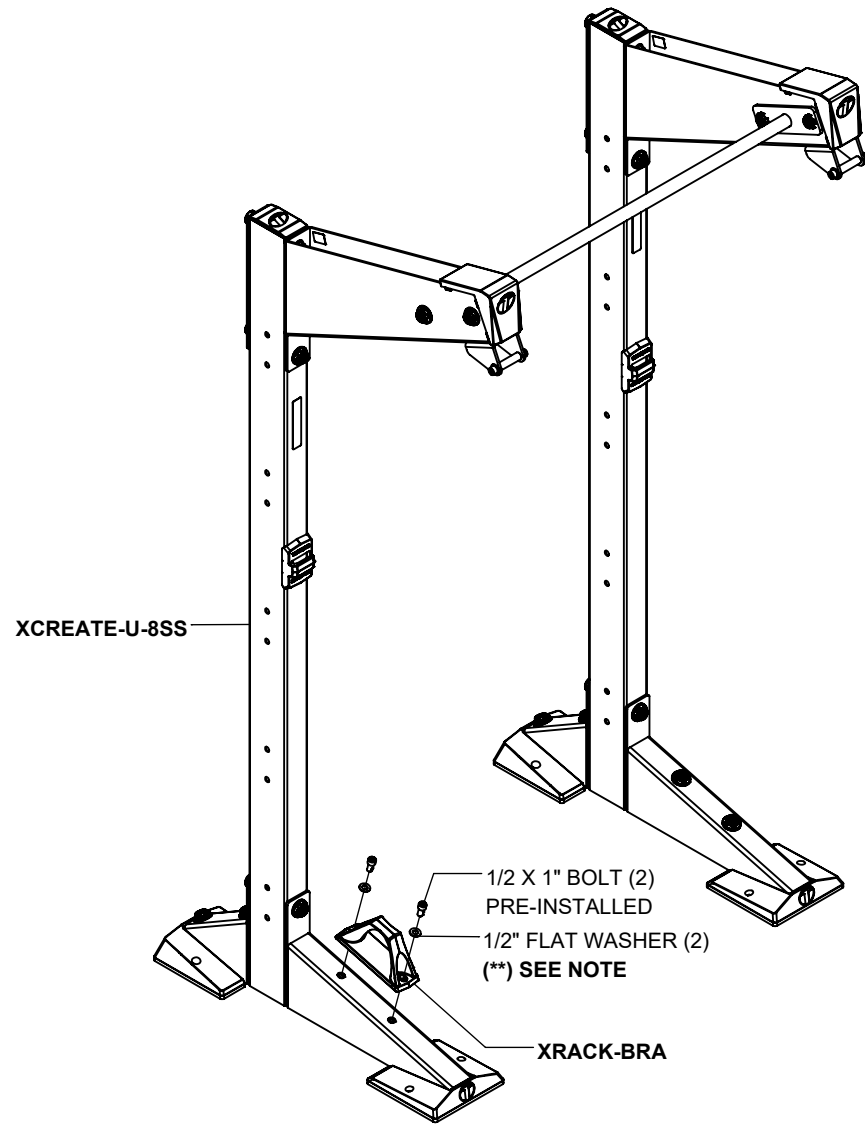

**NOTES:**

**SECURELY** tighten all bolt connections in this step.

(\*\*) **HARDWARE COVERS CANNOT** be used in this step.

The **XCREATE-U-7SS** is assembled the exact same way.

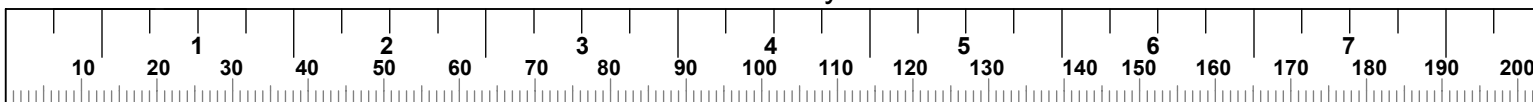

**XCREATE-HSH  
HANGING STORAGE HOOK**

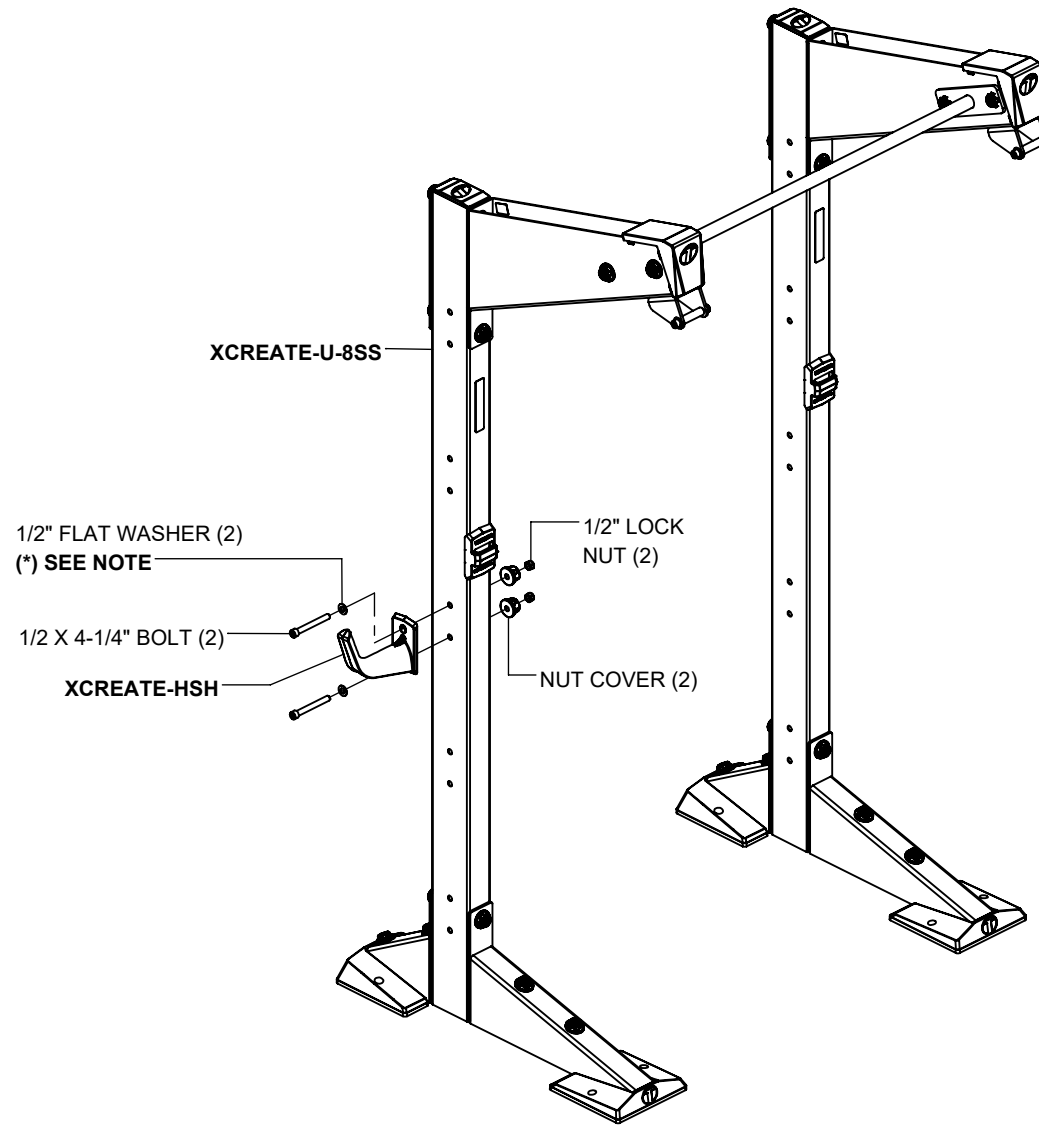

**NOTES:**

**SECURELY** tighten all bolt connections in this step.

(\*\*) **HARDWARE COVER CANNOT** be used on **HSH** side.

The **XCREATE-U-7SS** is assembled the exact same way.

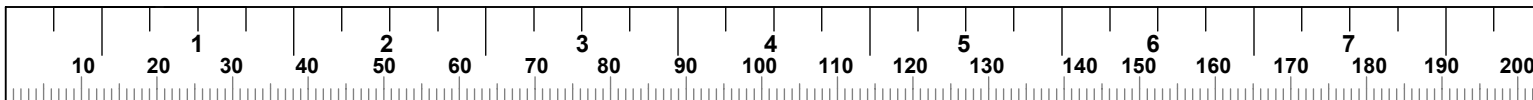

**XCREATE-DP**  
**DOUBLE PLAY (BAR & PLATE STORAGE)**

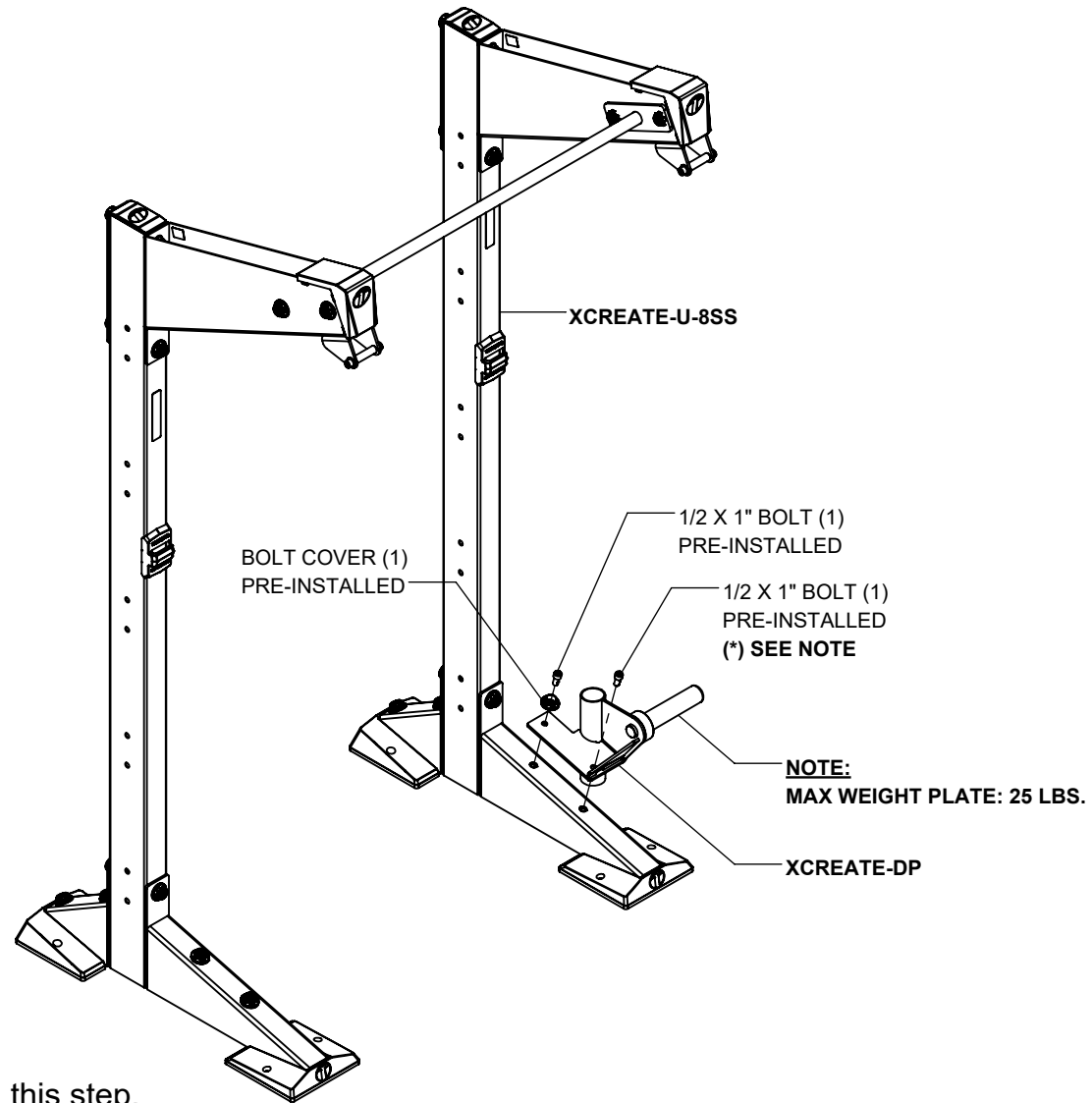

**NOTES:**

**SECURELY** tighten all bolt connections in this step.

(\* ) HARDWARE COVER **CAN** be used in place of washer.  
(SEE PAGE 3).

(\*\* ) HARDWARE COVER **CANNOT** be used in place of washer.

The **XCREATE-U-7SS** is assembled the exact same way.

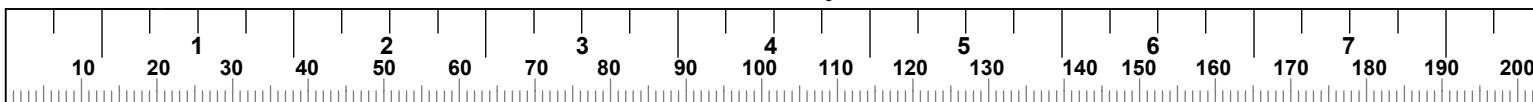

**XHMGRT  
HORIZONTAL MOUNT GROUND  
ROTATIONAL TRAINER**

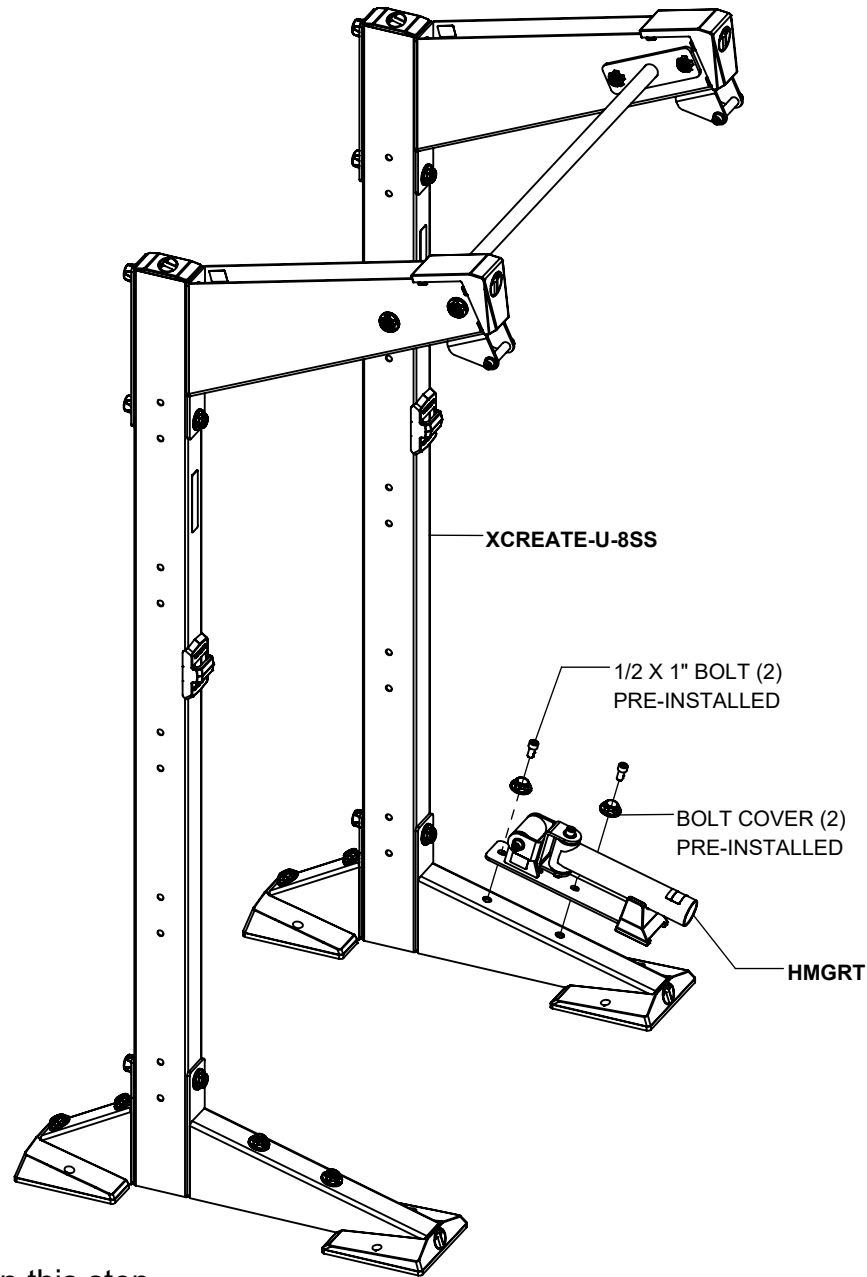

**NOTES:**

**SECURELY** tighten all bolt connections in this step.

The **XCREATE-U-7SS** is assembled the exact same way.

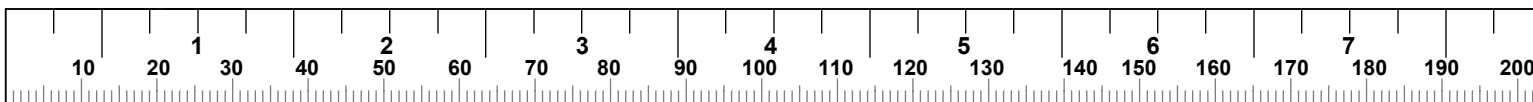

**XCREATE-3DS**  
**3 DIMENSIONAL SWIVEL**

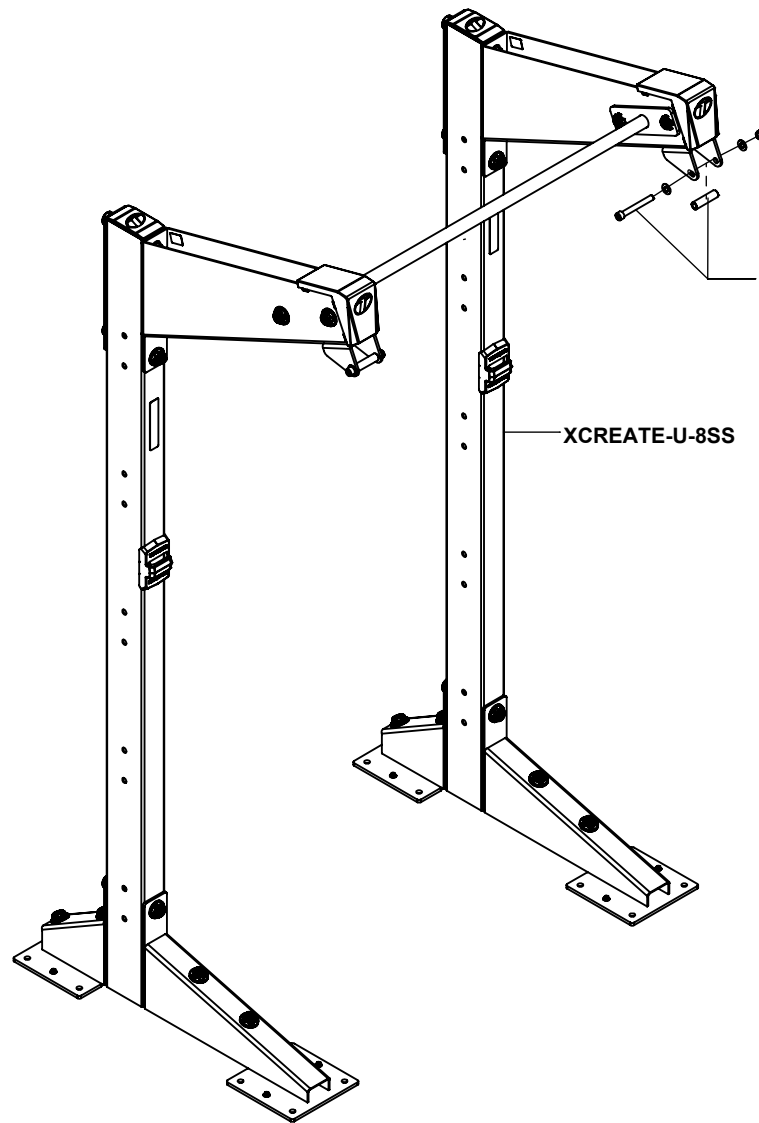

**NOTE:**  
TEMPORARILY REMOVE BOLT,  
SPACER, WASHERS AND NUT

XCREATE-U-8SS

**XCREATE-3DS**  
**3-DIMENSIONAL SWIVEL**

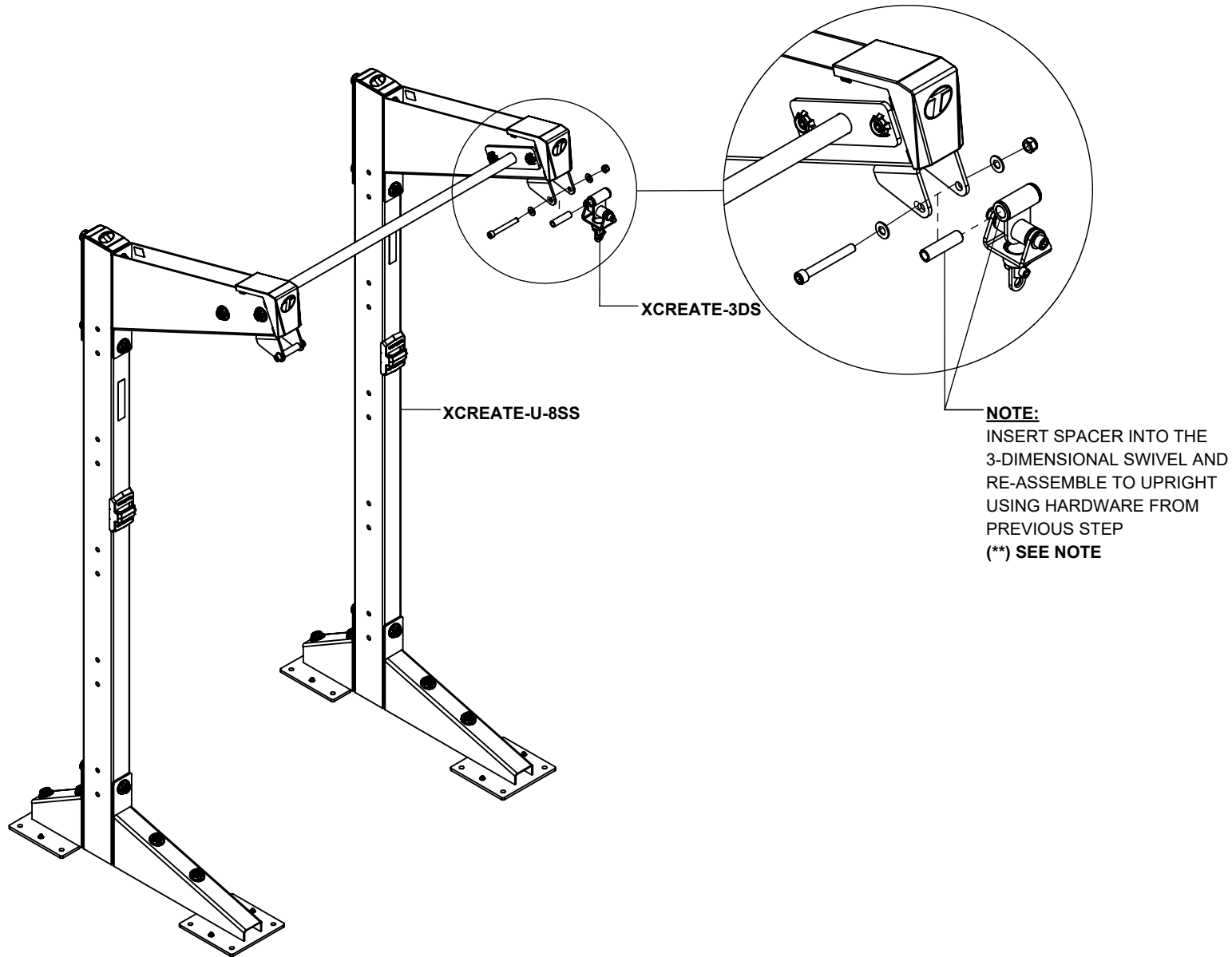

**NOTES:**

**SECURELY** assemble bolt connection in this step.

(\*\*) **HARDWARE COVERS** **CANNOT** be used in place of washers in this step.

# **XCREATE-BT BALL TARGET**

**NOTE:**

REMOVE SPACERS  
(2) AND DISCARD

**NOTE:**

REMOVE END CAP  
AND DISCARD

**NOTE:**

TEMPORARILY REMOVE  
BOLTS, HARDWARE COVERS AND NUTS

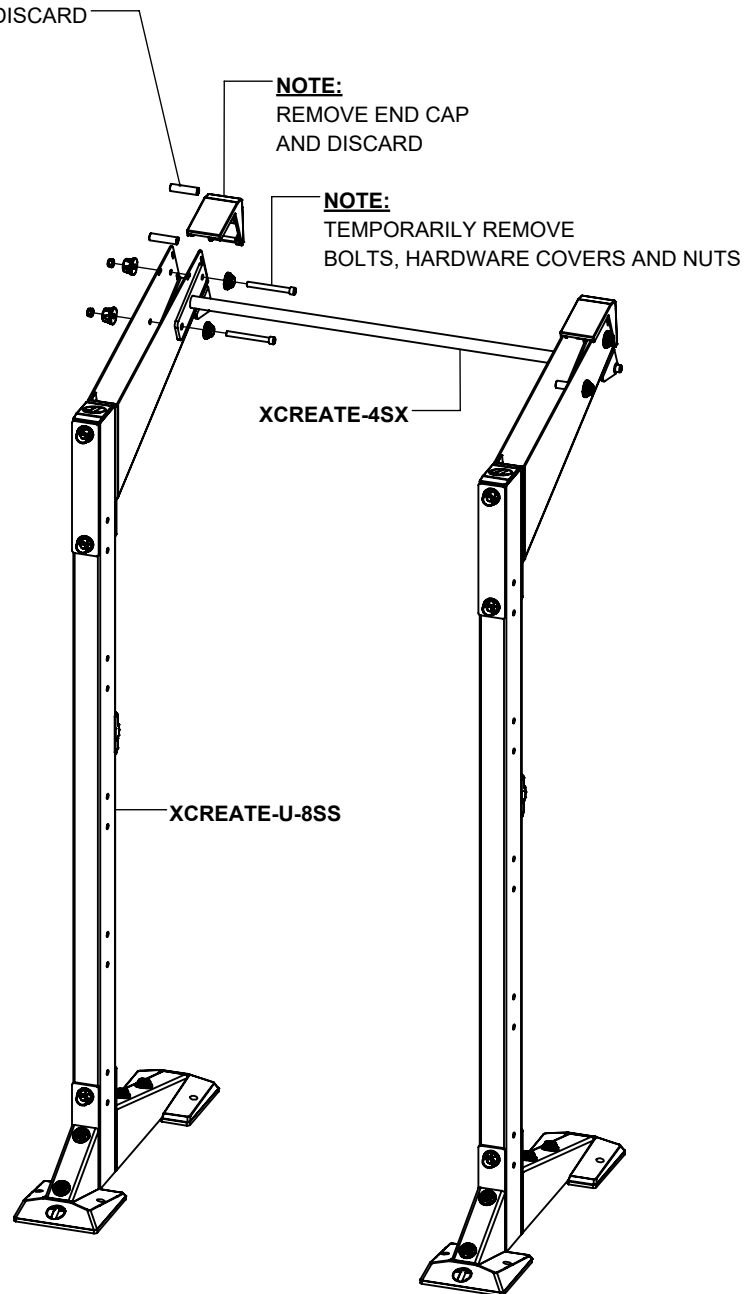



# ***XCREATE-BT BALL TARGET***

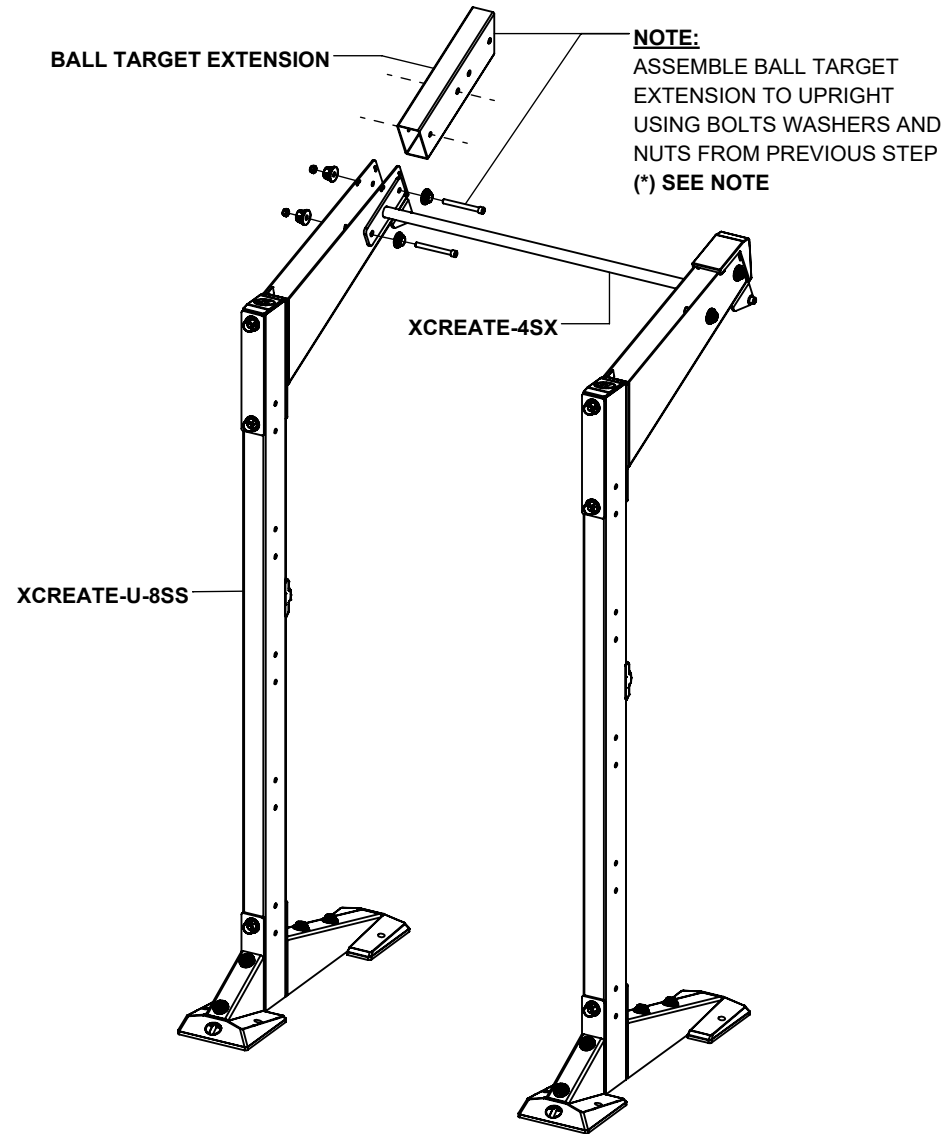

## **NOTES:**

**LOOSELY** assemble bolt connections in this step.

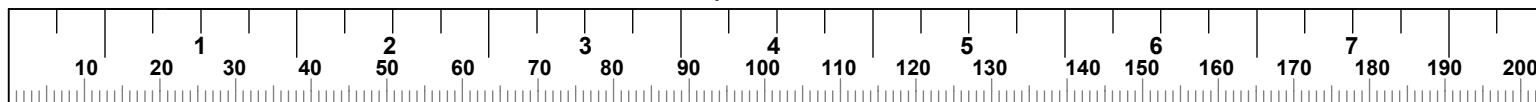

# **XCREATE-BT BALL TARGET**

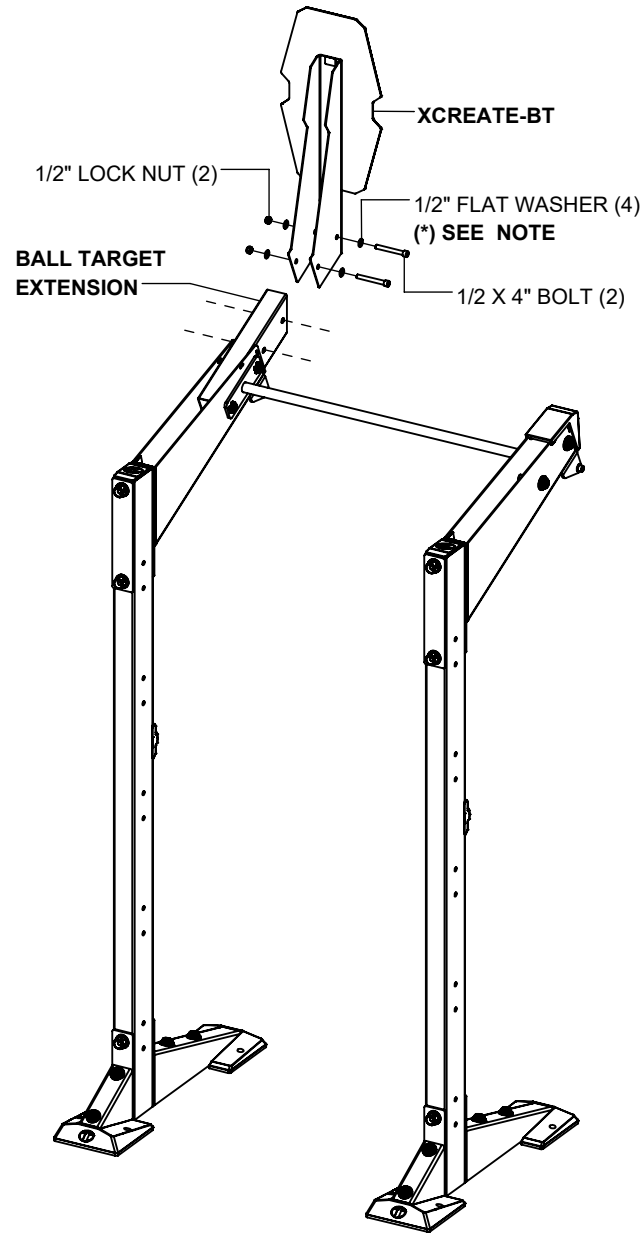

## **NOTES:**

After this step has been completed, **SECURELY** tighten all bolt connections from the last two steps.

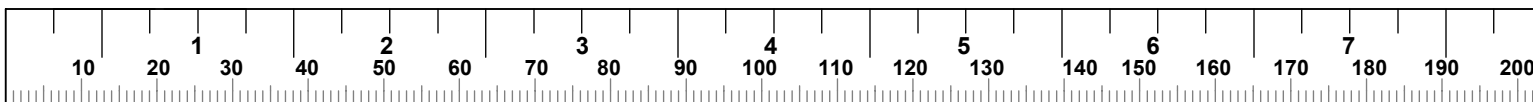

**XCREATE-RBA  
RESISTANCE BAND ANCHOR**

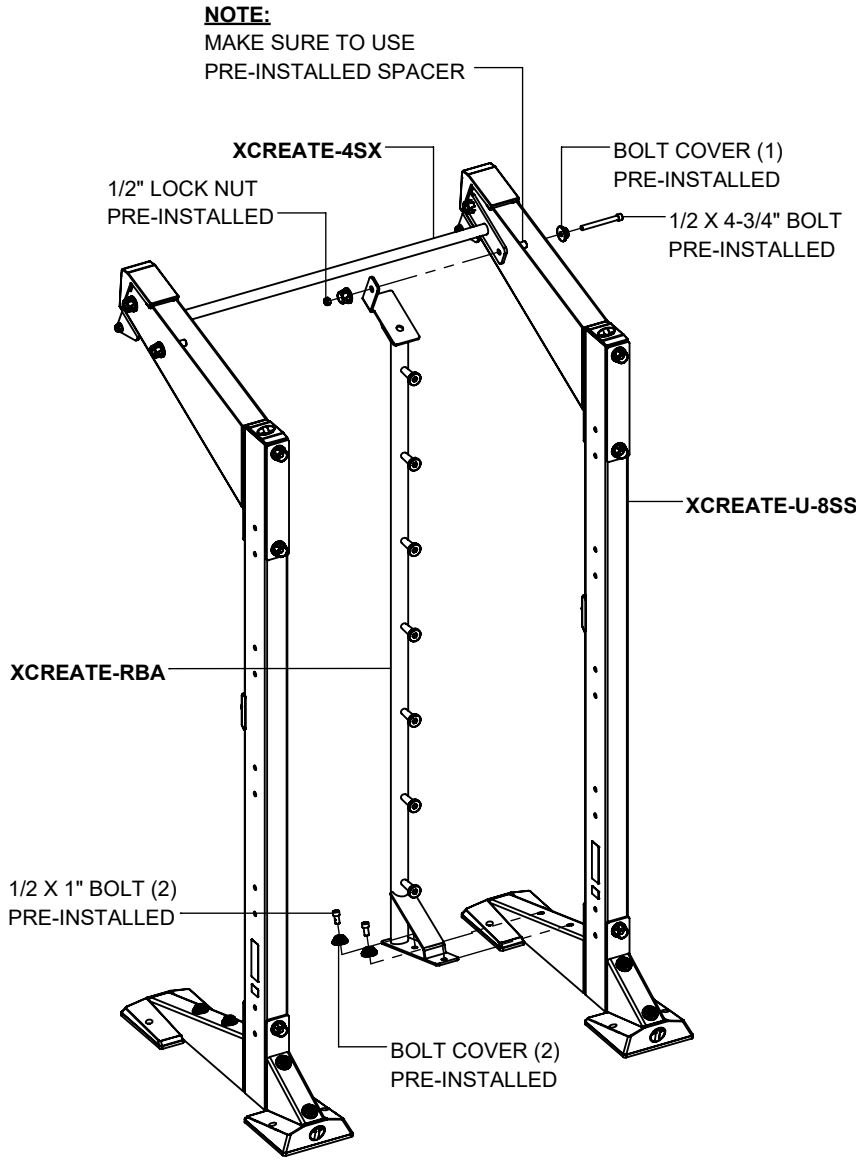

**NOTES:**

**SECURELY** tighten all bolt connections in this step.

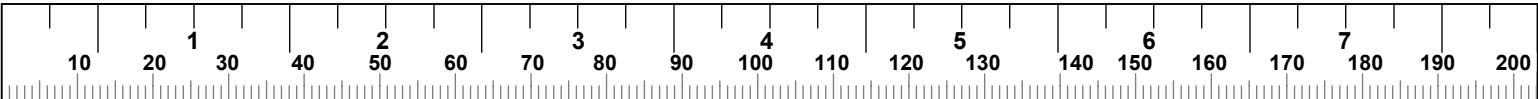

**XCREATE-VDS4 AND VDS5  
VERTICAL DUMBBELL STORAGE**

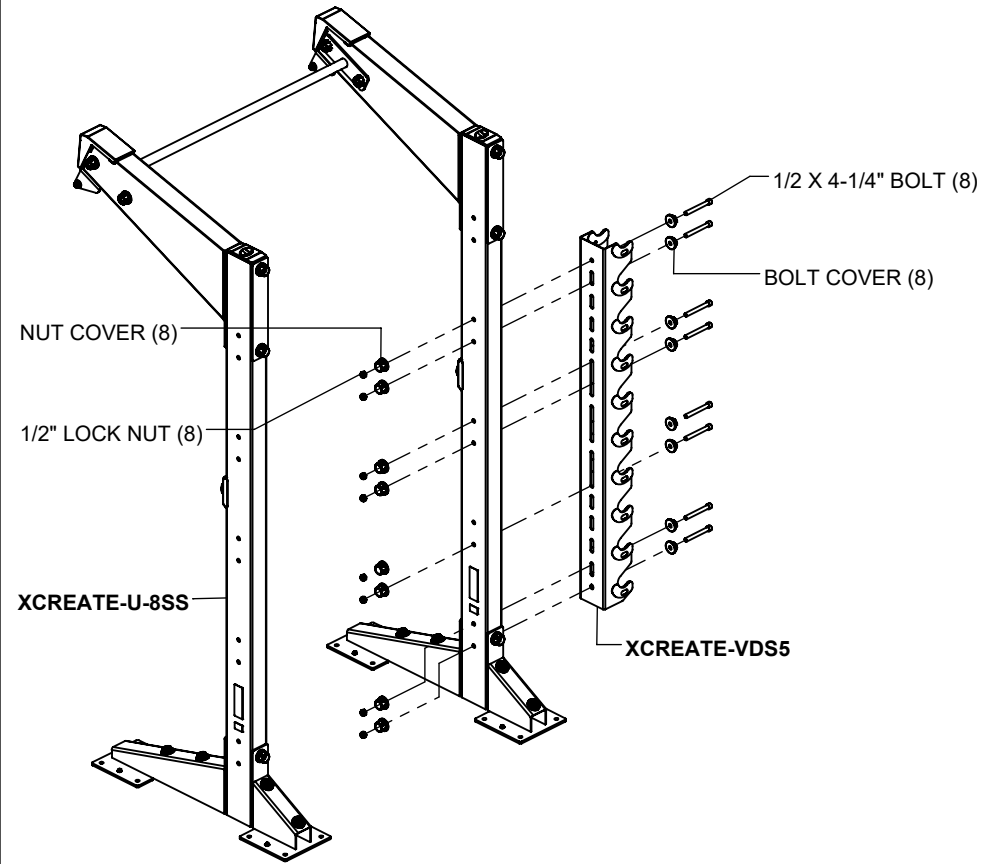
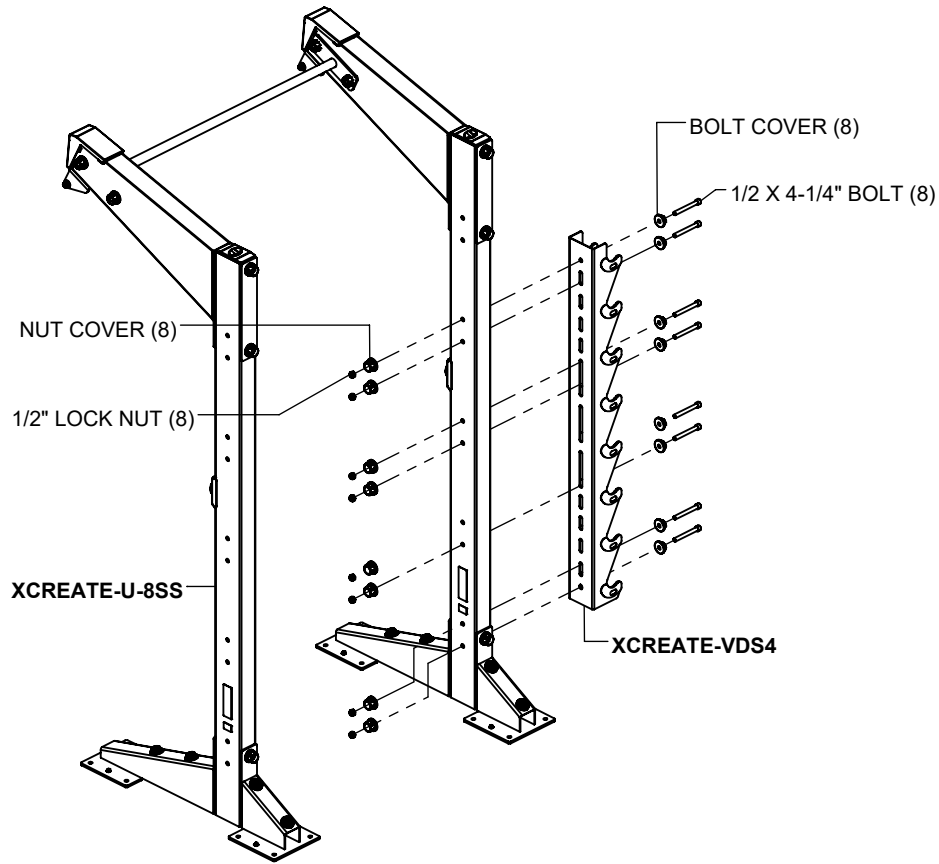

**NOTES:**

**SECURELY** tighten all bolt connections in this step.

The **XCREATE-U-7SS** is assembled the exact same way.

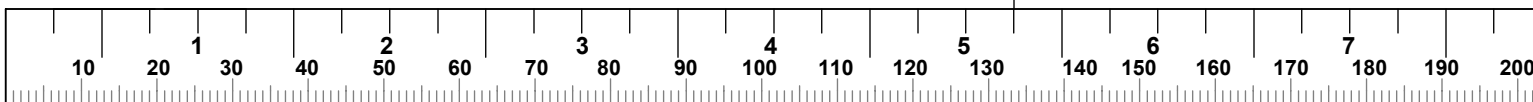

**XCREATE-4MGX  
4' MULTI GRIP CROSS**

**NOTE:**  
REMOVE END CAPS PRIOR  
TO ASSEMBLY RE-ATTACH  
END CAPS AFTER ASSEMBLY (2)

NUT COVER (4)  
(PRE-INSTALLED)

1/2" LOCK NUT (4)  
(PRE-INSTALLED)

**NOTE:**  
MAKE SURE TO USE PRE-  
INSTALLED SPACERS (4)

BOLT COVER (4)  
(PRE-INSTALLED)

1/2 X 4-3/4" BOLT (4)  
(PRE-INSTALLED)

XCREATE-4MGX

XCREATE-U-8SS (2)

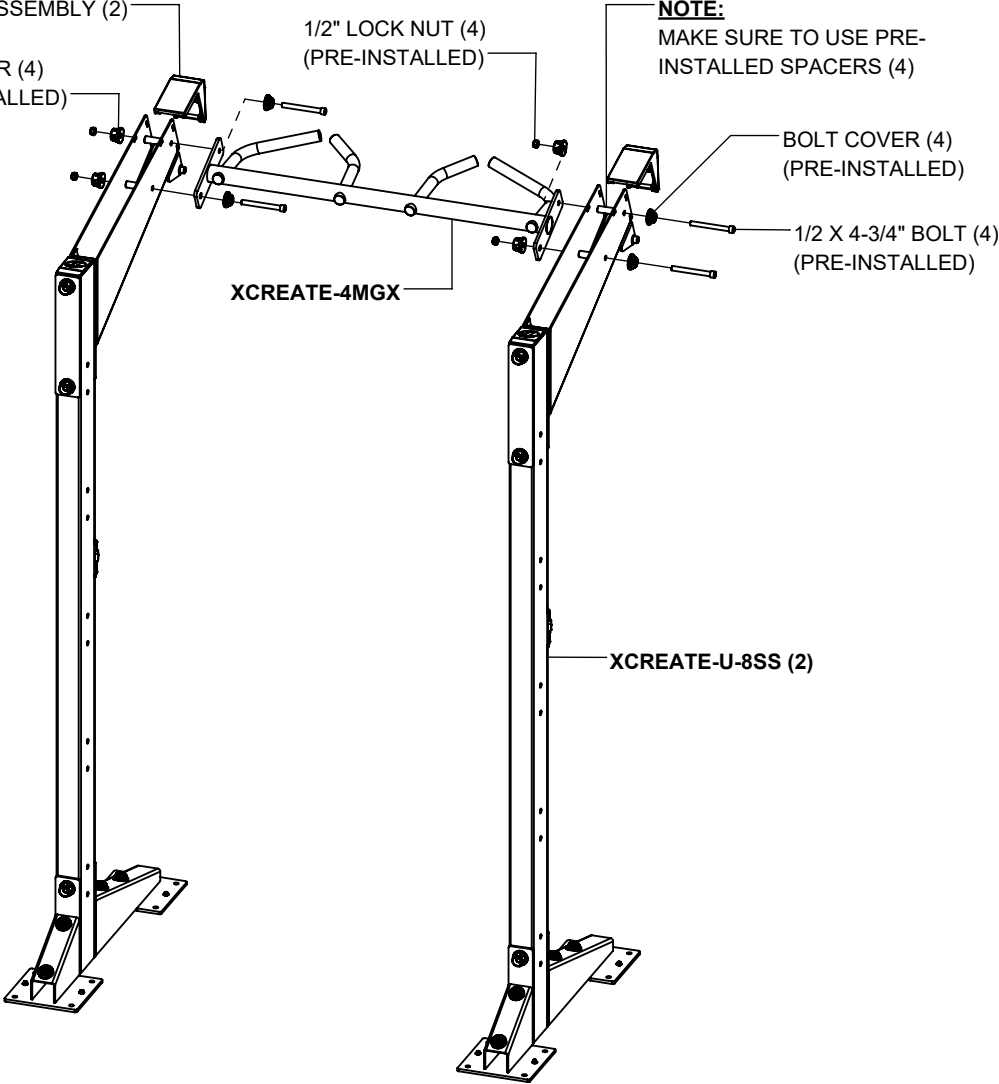

**NOTES:**

**SECURELY** tighten all bolt connections in this step.

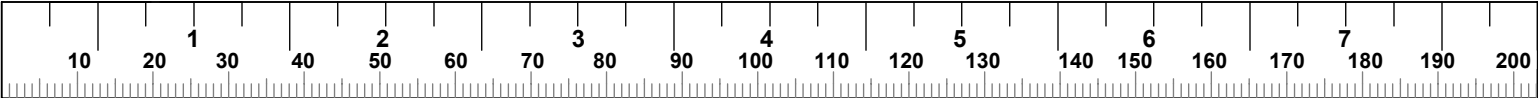

**XCREATE-4SSHWS**  
**4' SINGLE SIDE HORIZONTAL WEIGHT STORAGE**

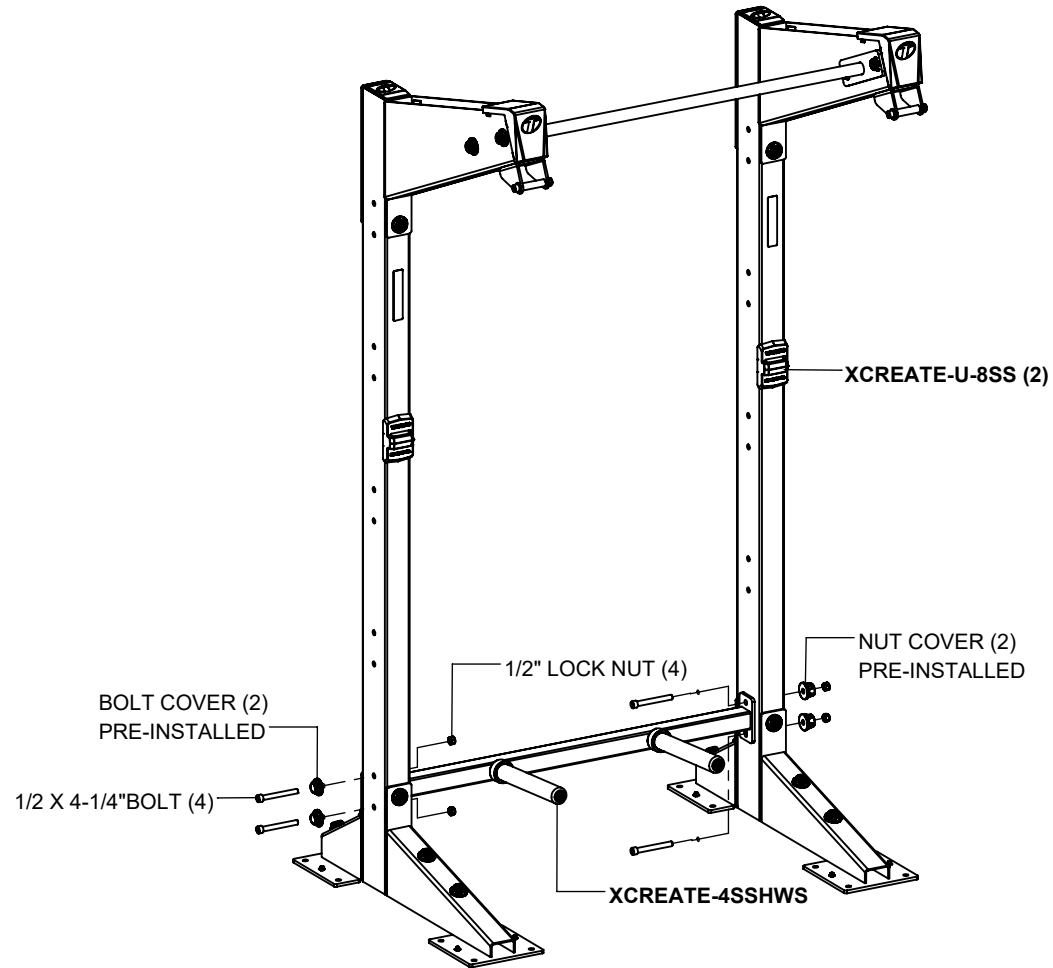

**NOTES:**

**SECURELY** tighten all bolt connections in this step.

(\*\*) **HARDWARE COVERS CANNOT** be used on plate side.

The **XCREATE-U-7SS** is assembled the exact same way.

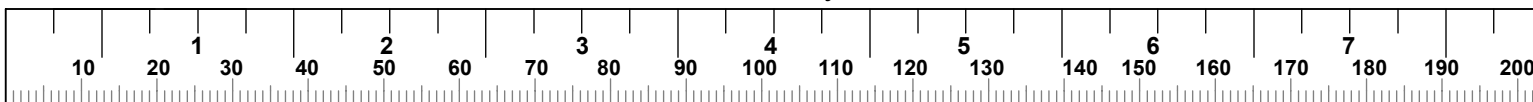

**XCREATE-TBE  
TOP BOOM EXTENSION**

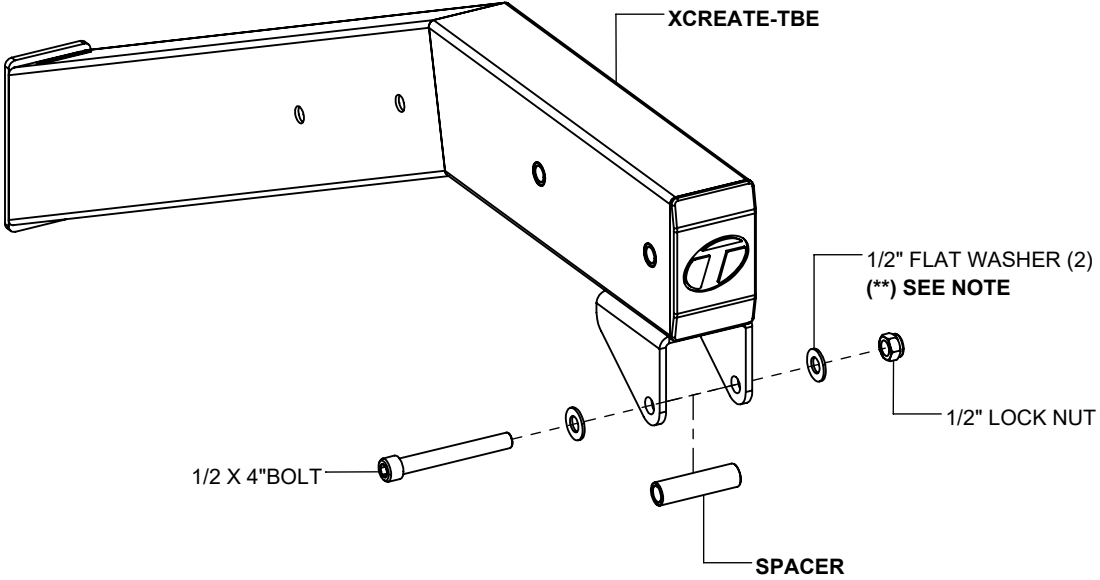

**NOTES:**

**SECURELY** tighten bolt connection in this step.

(\*\*) **HARDWARE COVERS CANNOT** be used in place of washers in this step.

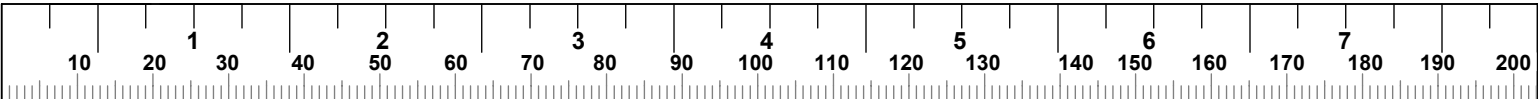

**XCREATE-TBE  
TOP BOOM EXTENSION**

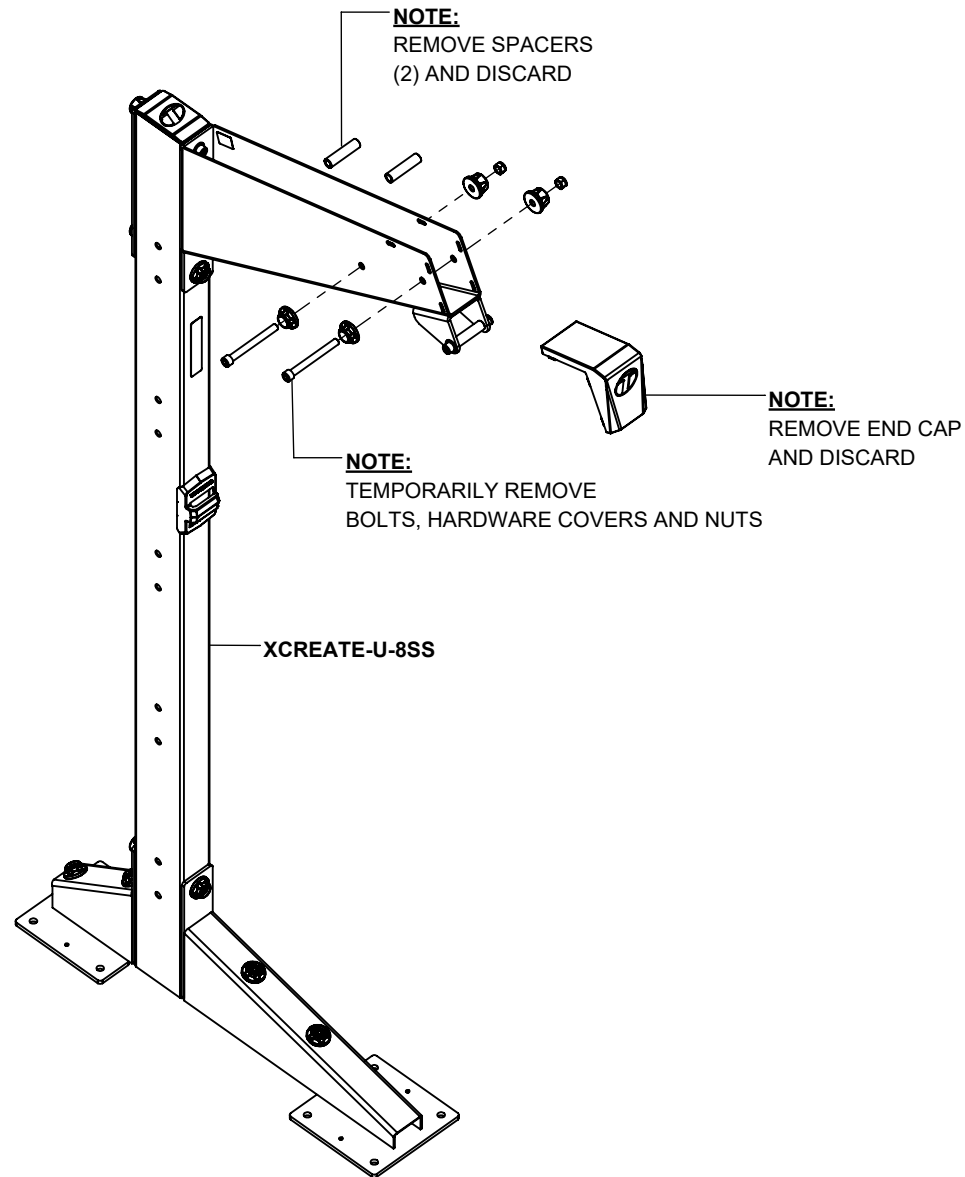

**NOTE:**

Repeat this step for as many TOP BOOM EXTENSIONS there are to assemble.



**XCREATE-TBE  
TOP BOOM EXTENSION**

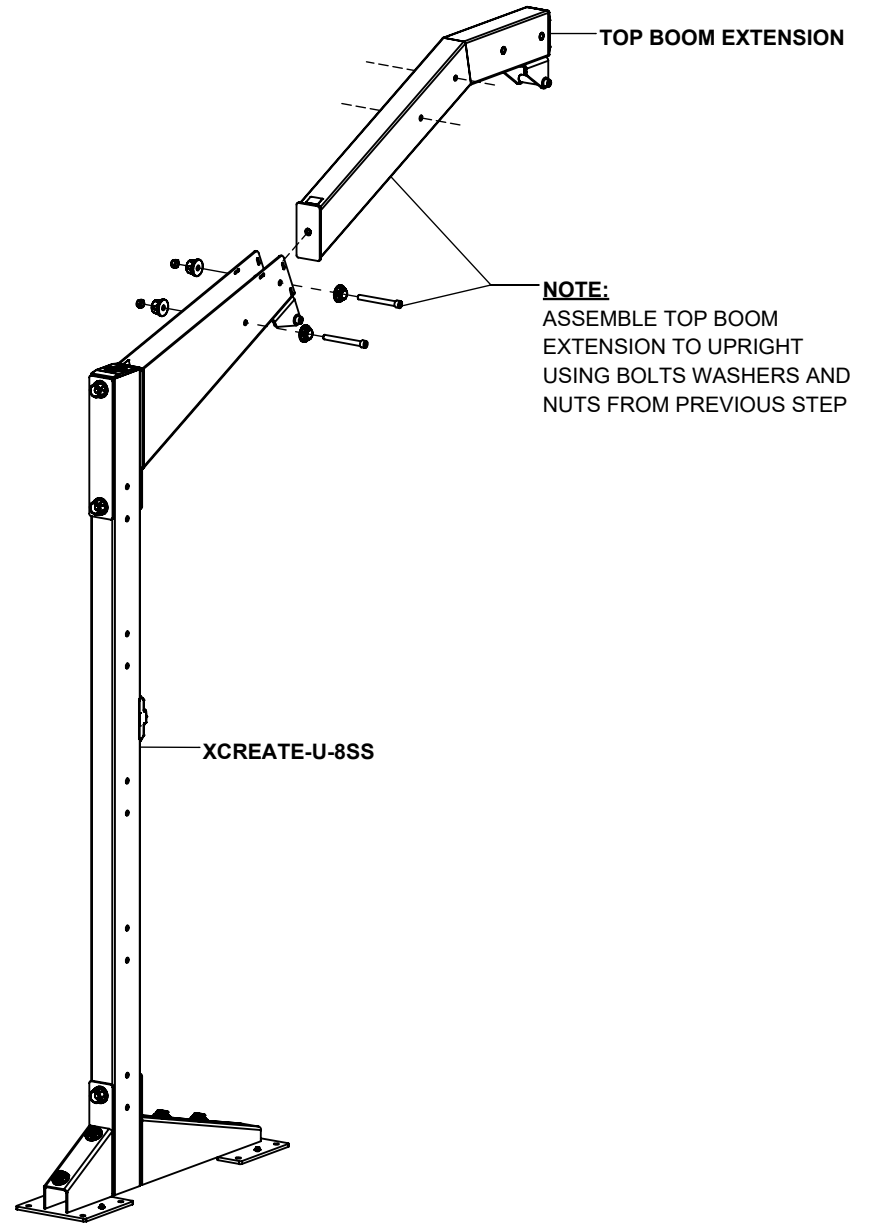

**NOTES:**

Repeat this step for as many TOP BOOM EXTENSIONS there are to assemble.

If only one TOP BOOM EXTENSION is being assembled, then **SECURELY** tighten all bolt connections in this step.

If joining two TOP BOOM EXTENSIONS together, then keep all bolt connections loose until next step.

(\* ) HARDWARE COVERS **CAN** be used in place of washers in this step. (SEE PAGE 3).

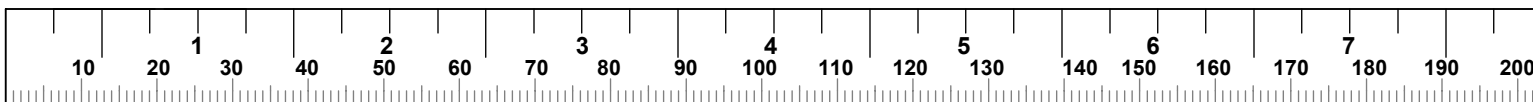

**XCREATE-TBE  
TOP BOOM EXTENSION**

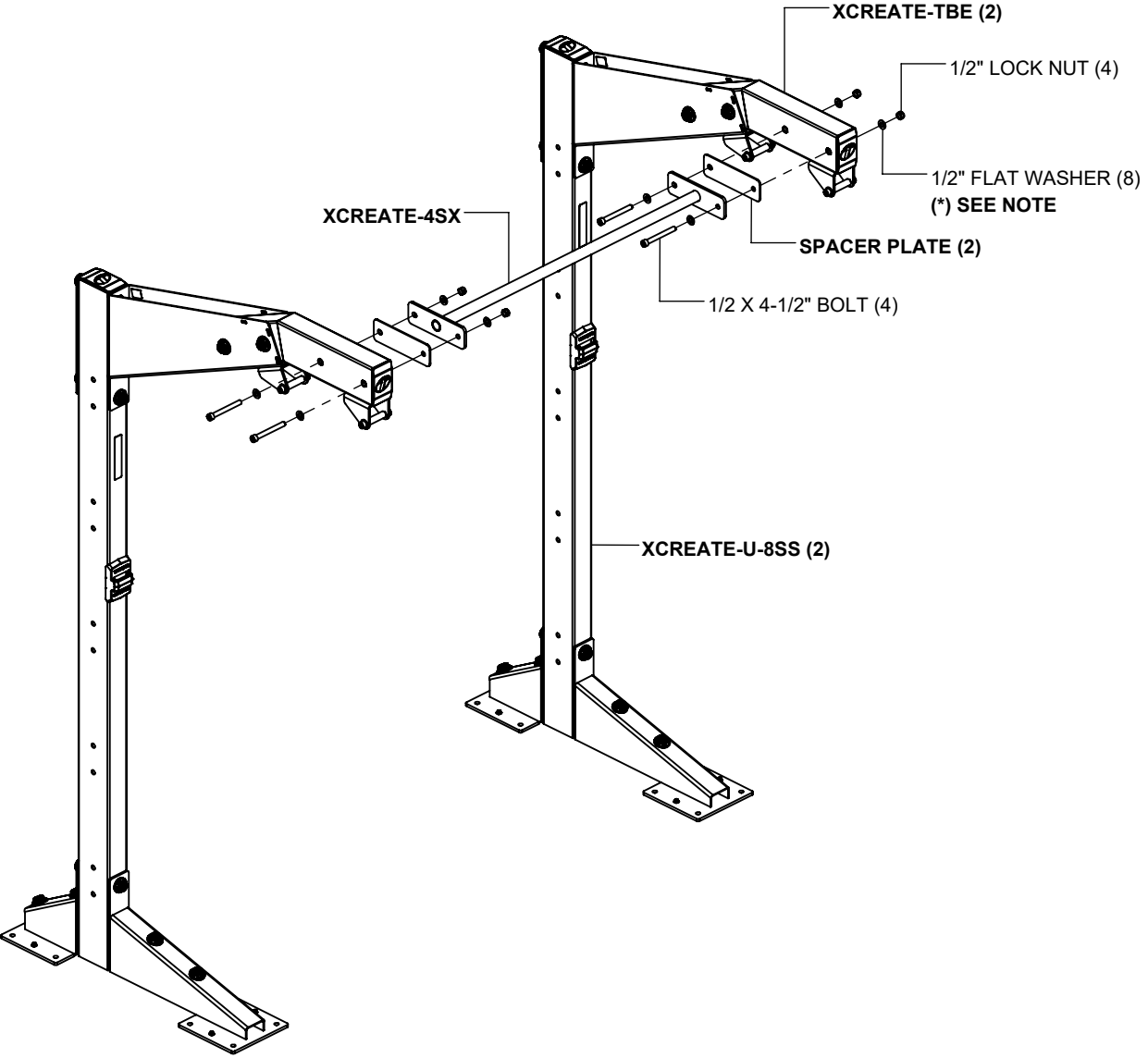

**NOTES:**

**SECURELY** tighten all bolt connections in this step.

(\* **HARDWARE COVERS CAN** be used in place of washers in this step. **(SEE PAGE 3)**).

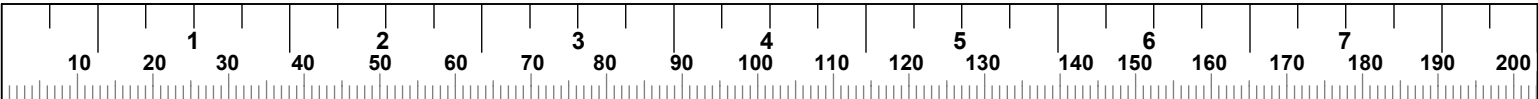

# XCREATE-AA ATTACHMENT ANCHOR

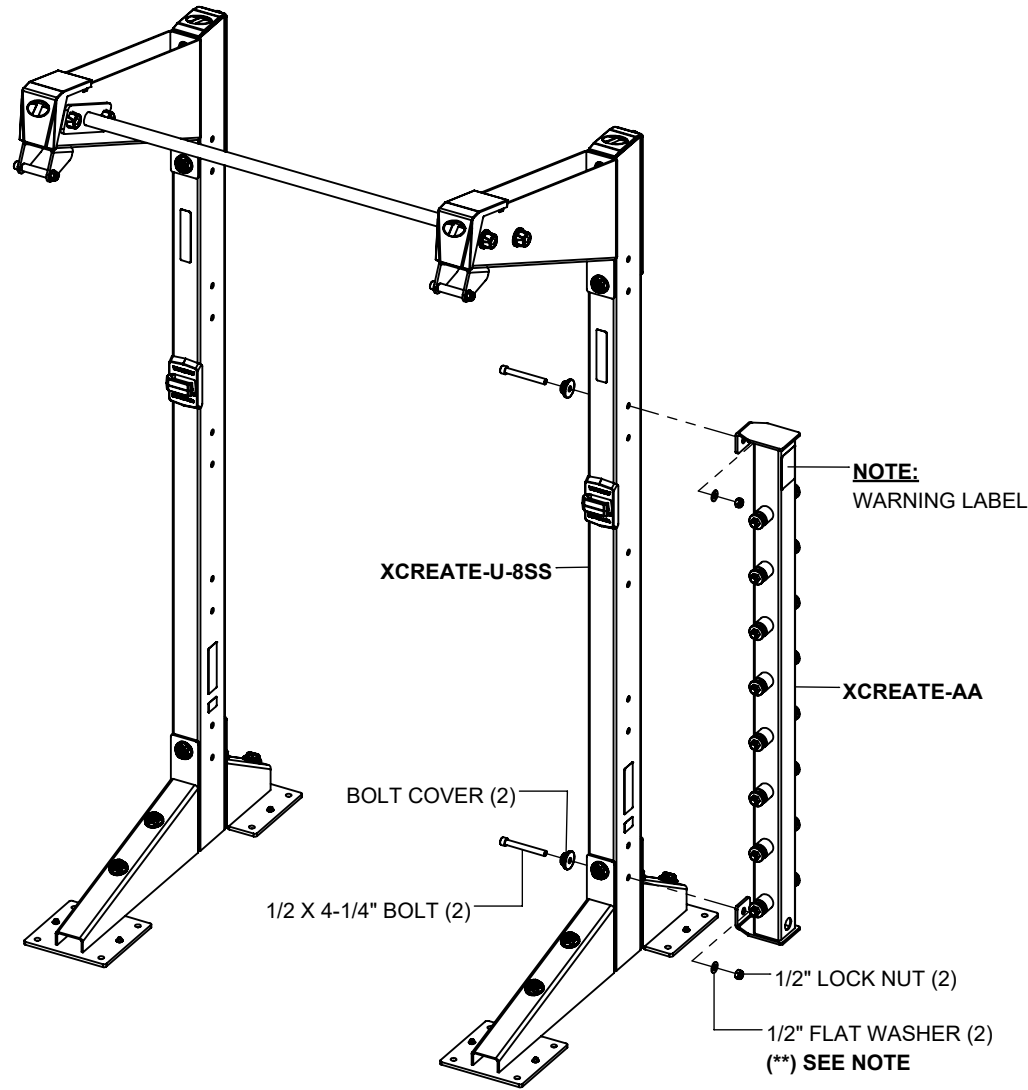

## NOTES:

**SECURELY** tighten all bolt connections in this step.

(\*\*) **HARDWARE COVERS CANNOT** be used on plate side.

The **XCREATE-U-7SS** is assembled the exact same way.

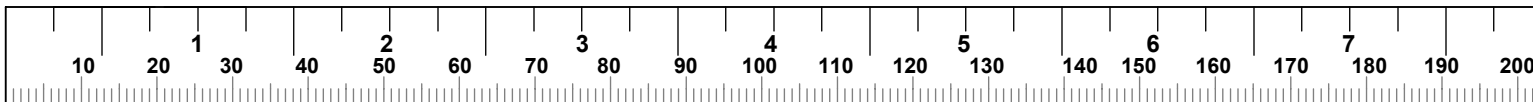

**XCREATE-DA  
DIP ATTACHMENT**

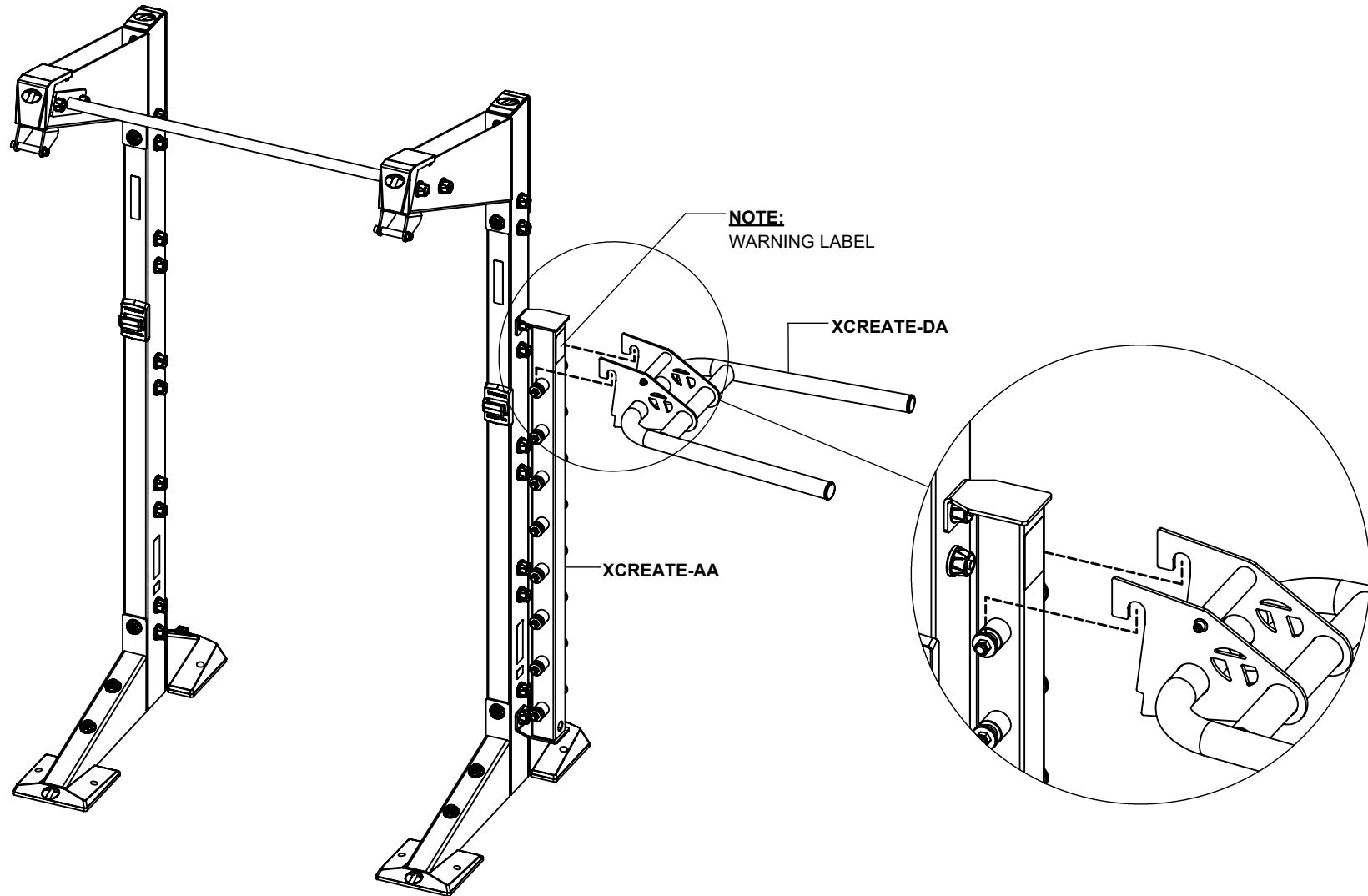

**XCREATE-PS  
PLYO STEP**

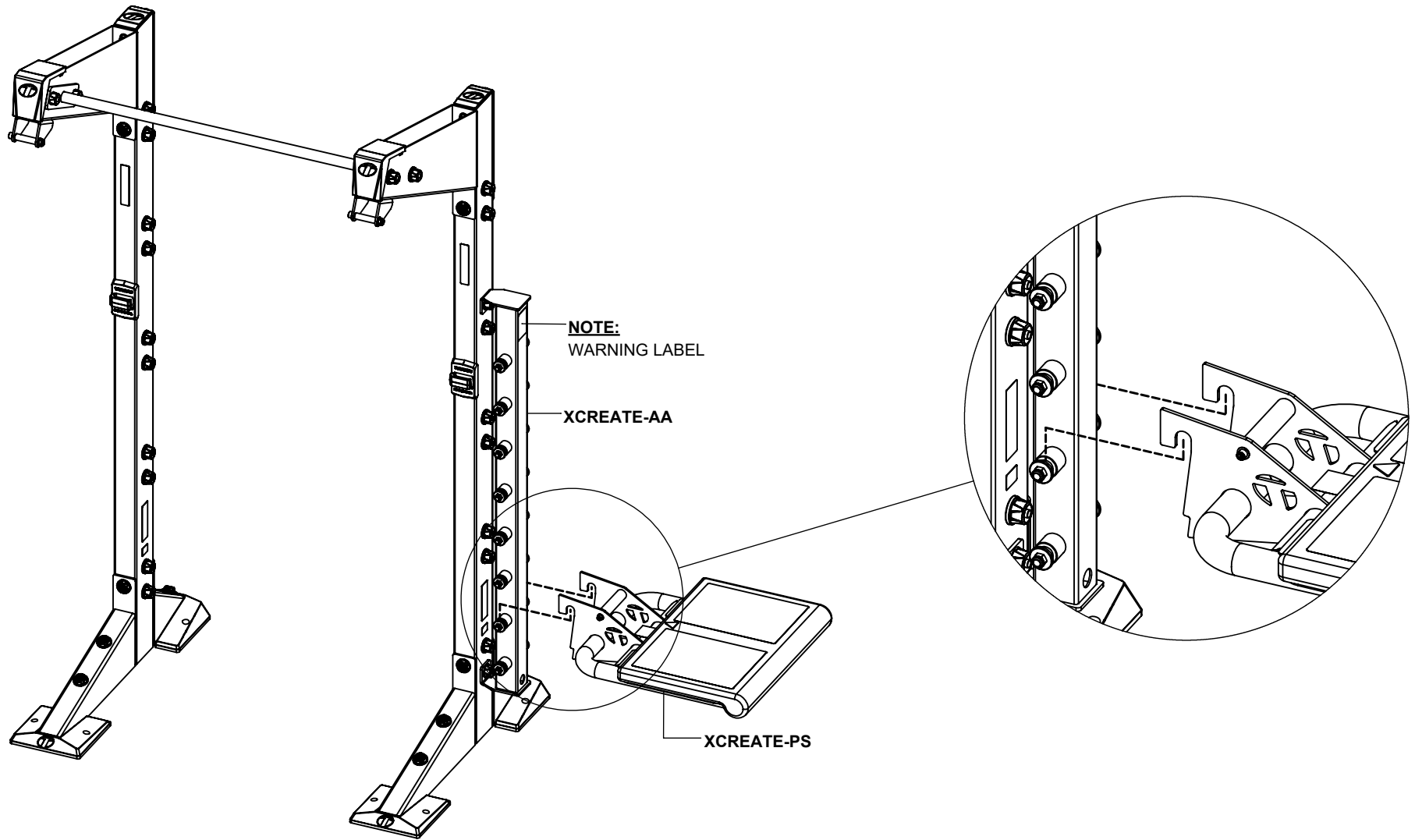

**XCREATE-AE  
ATTACHMENT EXTENSION**

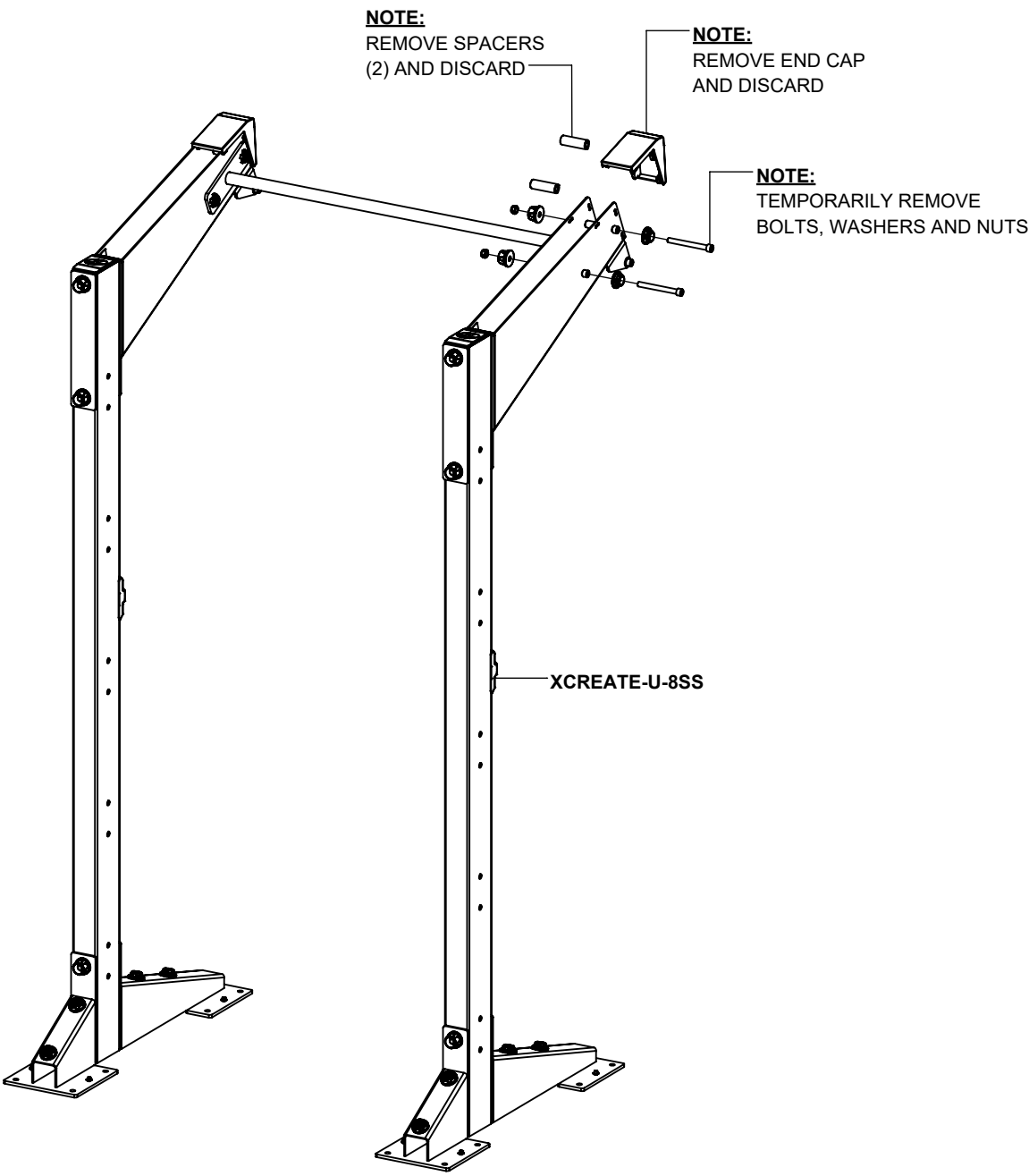

# ***XCREATE-AE ATTACHMENT EXTENSION***

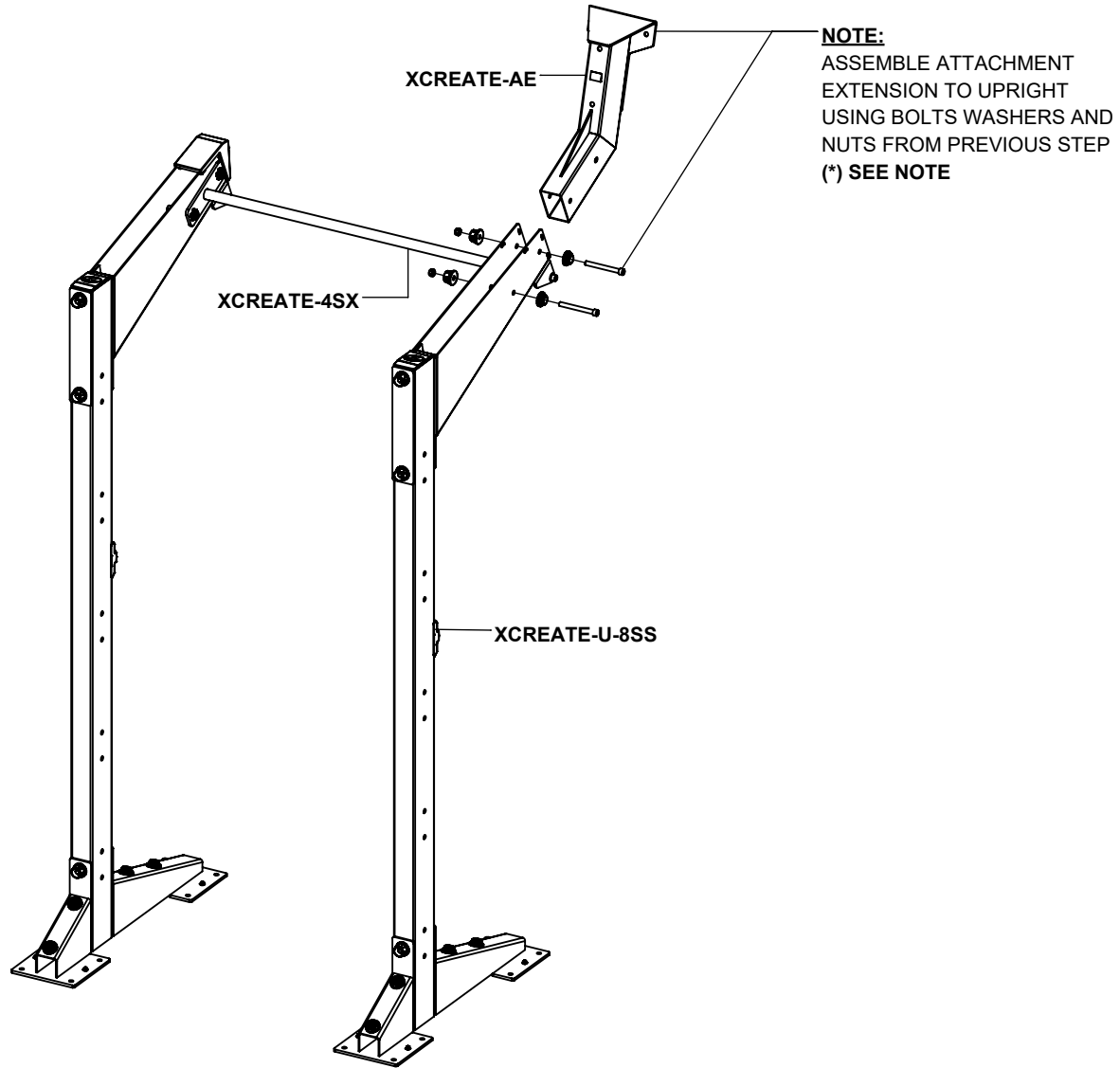

## **NOTES:**

**SECURELY** assemble bolt connections in this step.

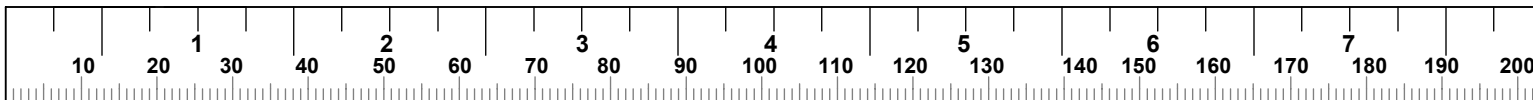

# **XCREATE-AE & XCREATE-3DSM ATTACHMENT EXTENSION AND 3 DIMENSIONAL SWIVEL W MOUNT**

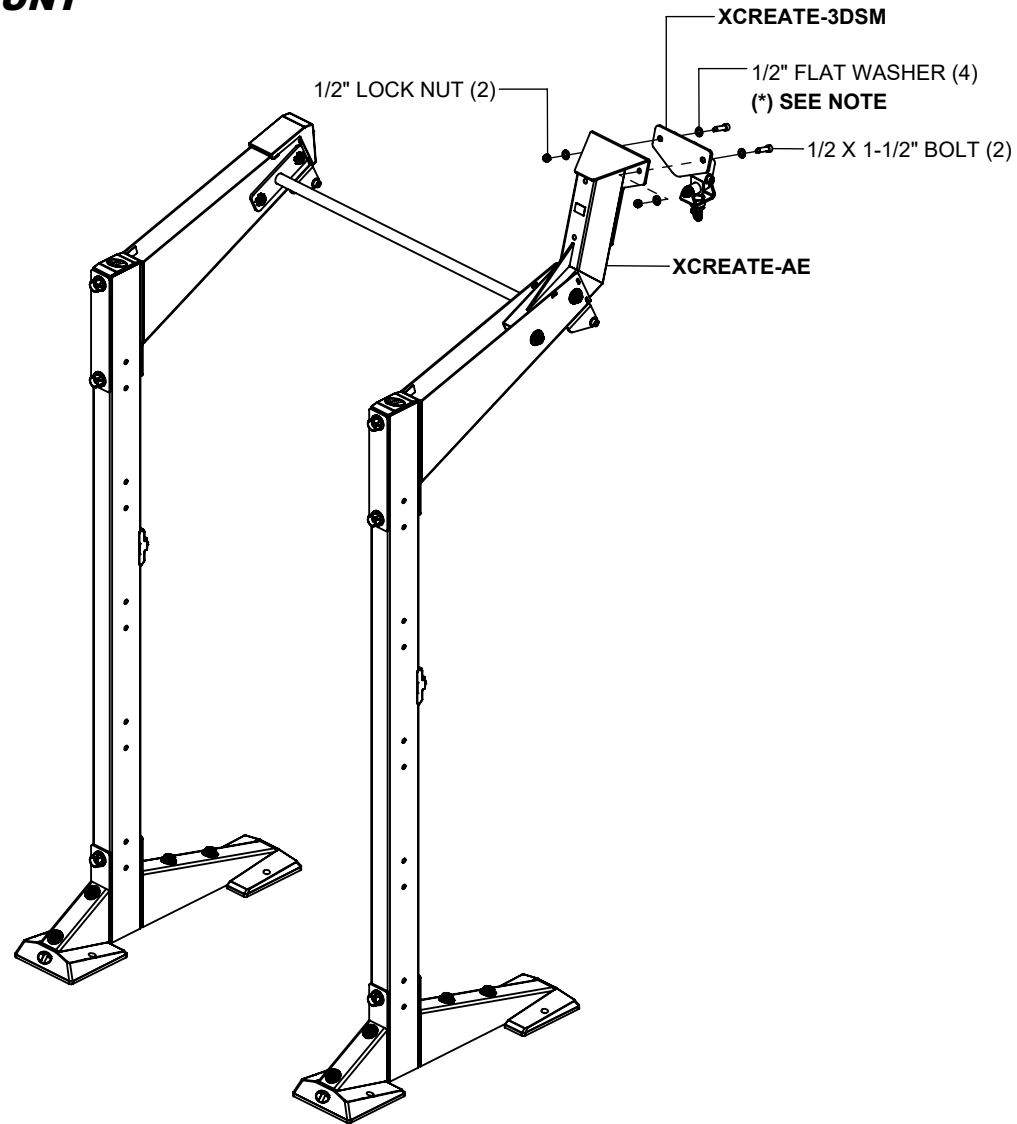

## **NOTES:**

**SECURELY** assemble bolt connections in this step.

(\* ) HARDWARE COVERS **CAN** be used in place of washers in this step. (SEE PAGE 3).

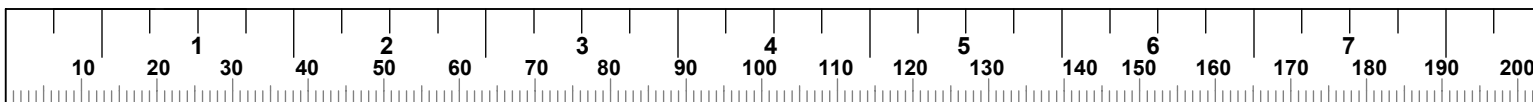



**XERT  
RELENTLESS ROPE TRAINER (UPRIGHT MOUNT)**

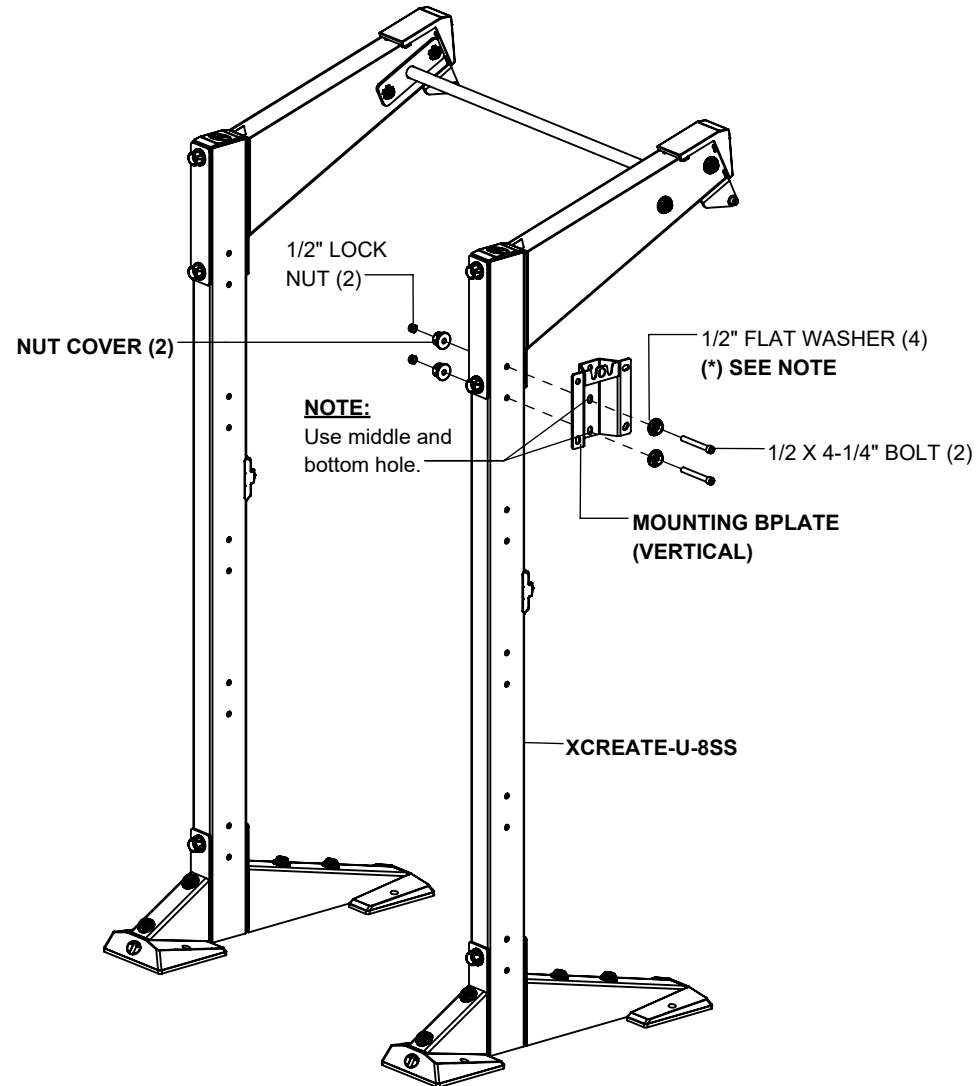

**NOTES:**

**SECURELY** tighten all bolt connections in this step.

(\* ) HARDWARE COVERS **CAN** be used in place of washers in this step. (SEE PAGE 3).

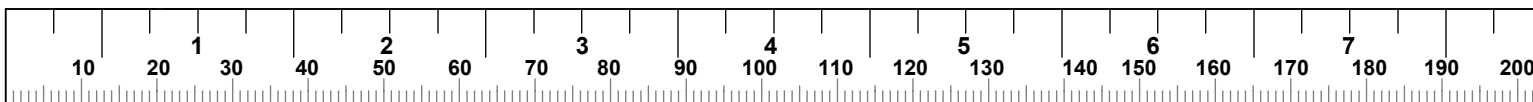

**XERT  
RELENTLESS ROPE TRAINER (UPRIGHT MOUNT)**

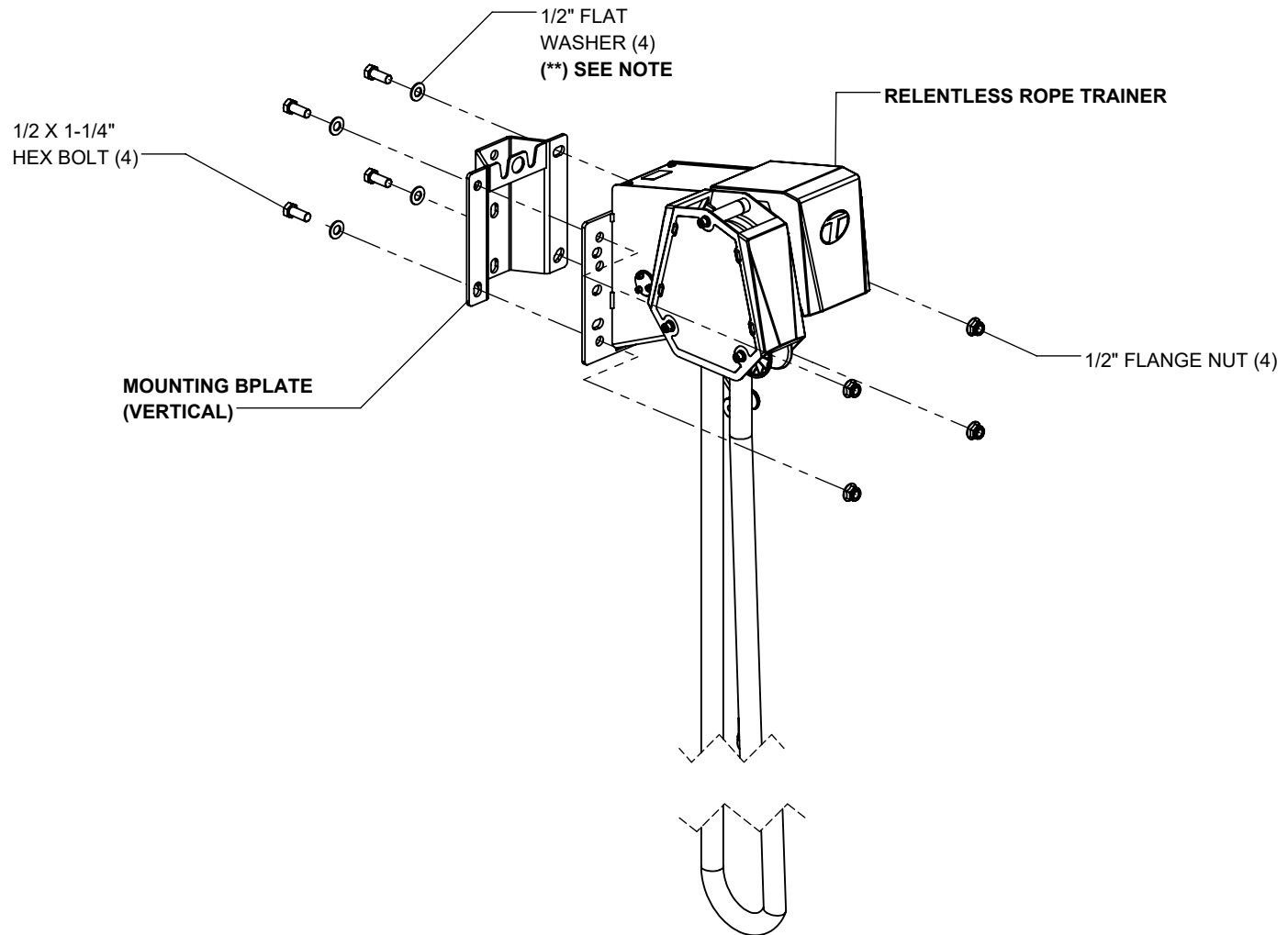

**NOTES:**

**SECURELY** tighten all bolt connections in this step.

(\*\*) **HARDWARE COVERS CANNOT** be used in place of washers in this step.

XCREATE has been hidden for assembly clarity.

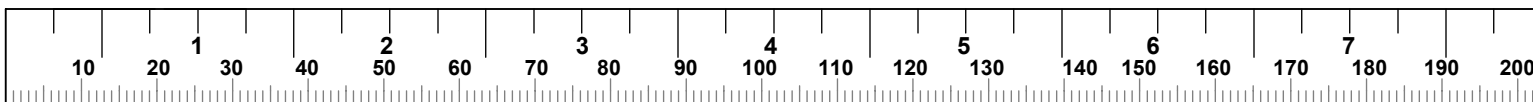

**XCREATE-BMXERT  
BOOM MOUNT**

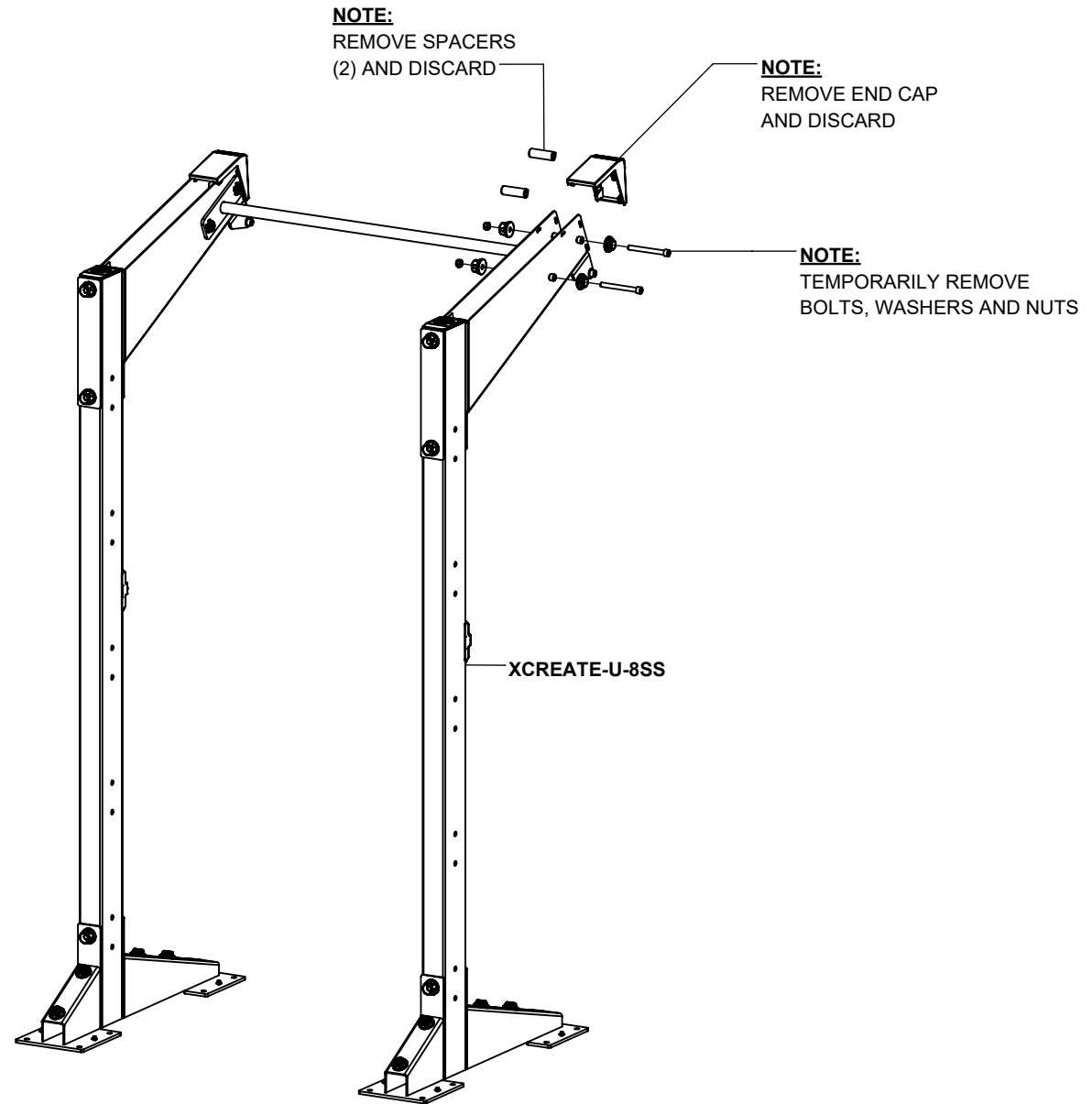

# **XCREATE-BMXERT BOOM MOUNT**

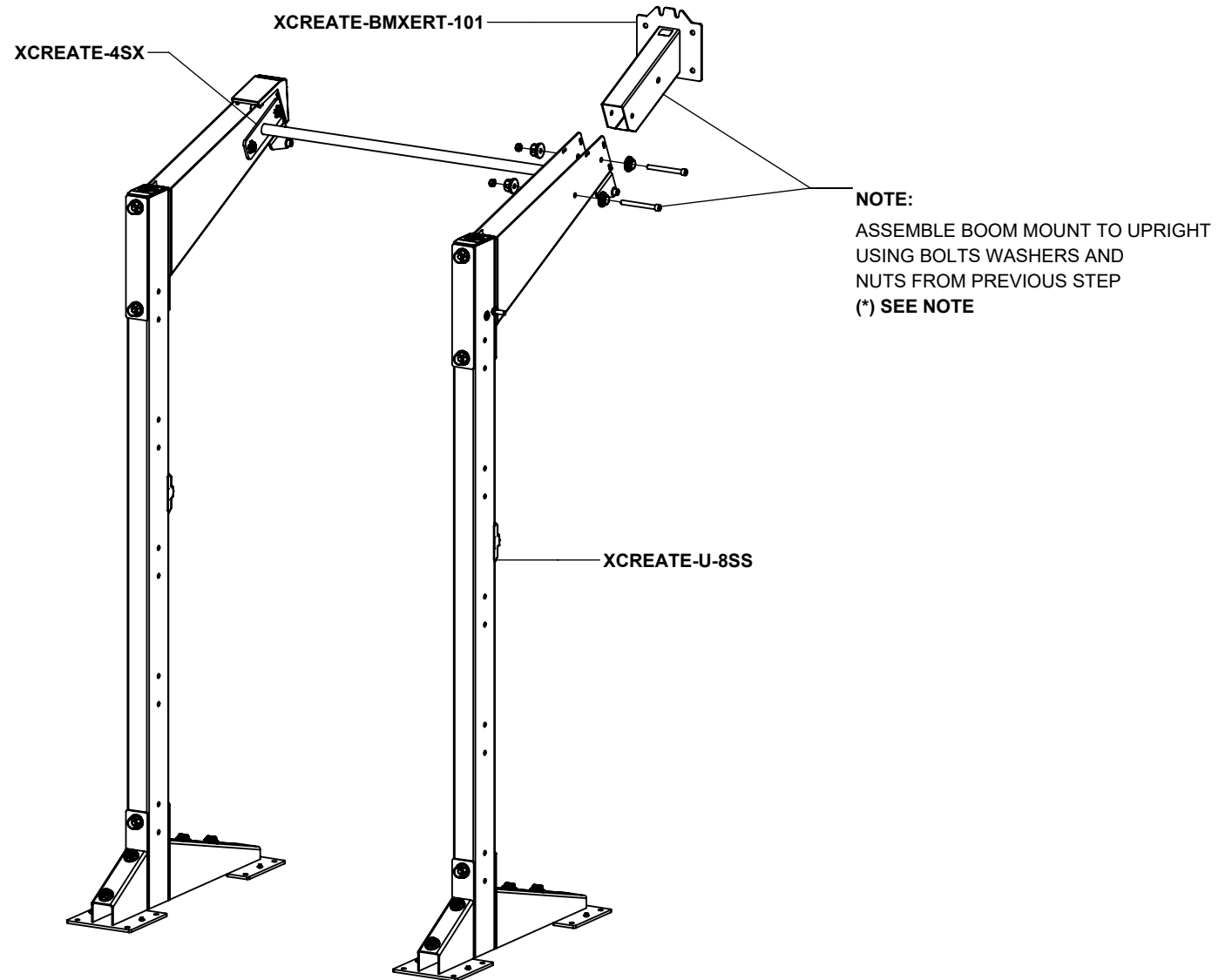

## **NOTE:**

**SECURELY** tighten all bolt connections in this step.

(\* **HARDWARE COVERS** **CAN** be used in place of washers in this step. (**SEE PAGE 3**)

# XCREATE-BMXERT RELENTLESS ROPE TRAINER / RELENTLESS RIPPER

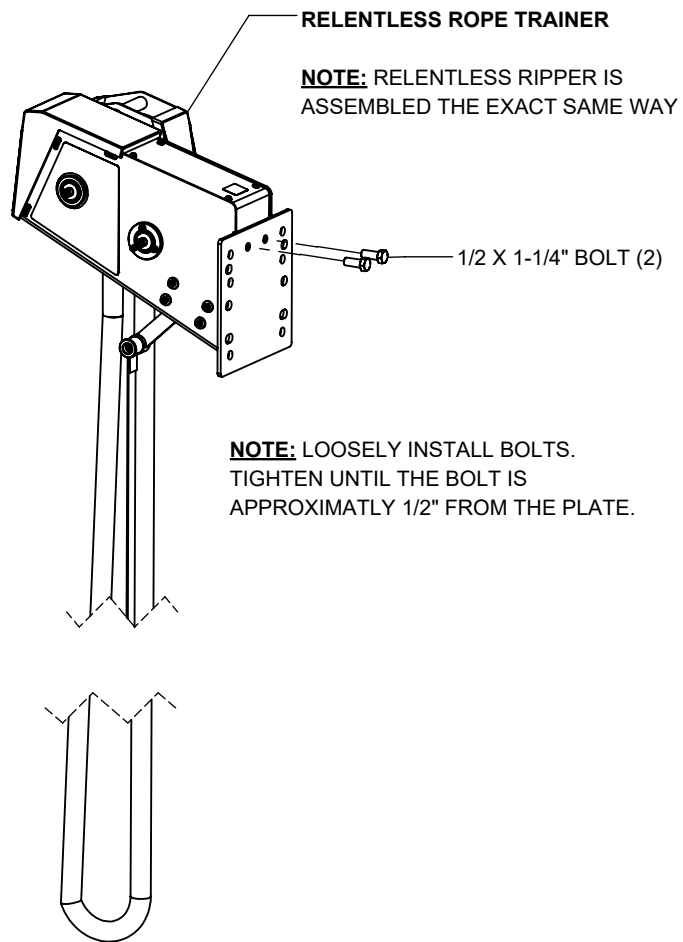

## **NOTE:**

The **Relentless Rope Trainer** is shown, follow the exact same steps to assemble the **Relentless Ripper**.

(\*\*) **HARDWARE COVERS** **CANNOT** be used in place of washers in this step.

XCREATE has been hidden for assembly clarity.

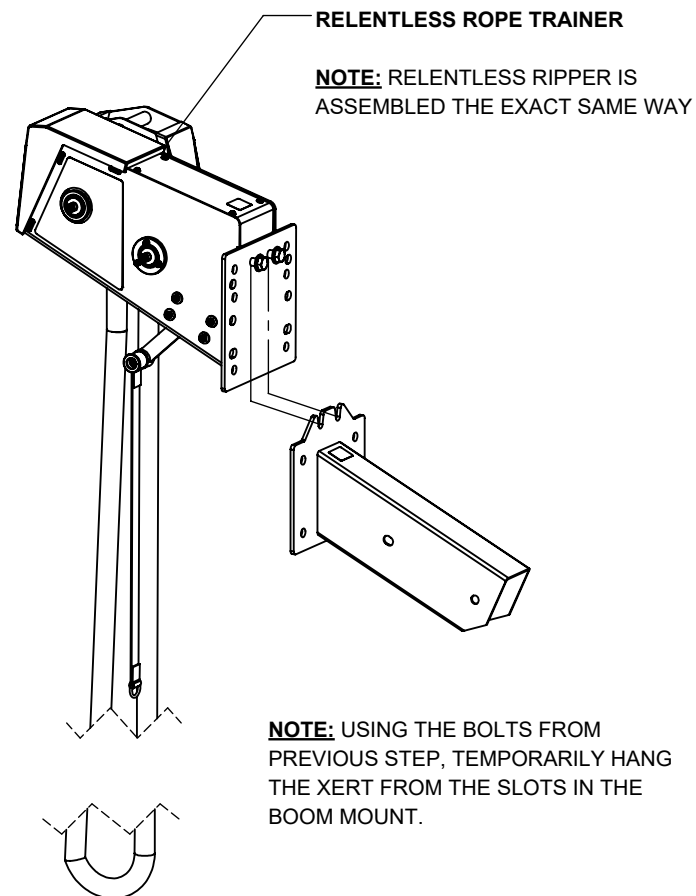

# XCREATE-BMXERT RELENTLESS ROPE TRAINER / RELENTLESS RIPPER

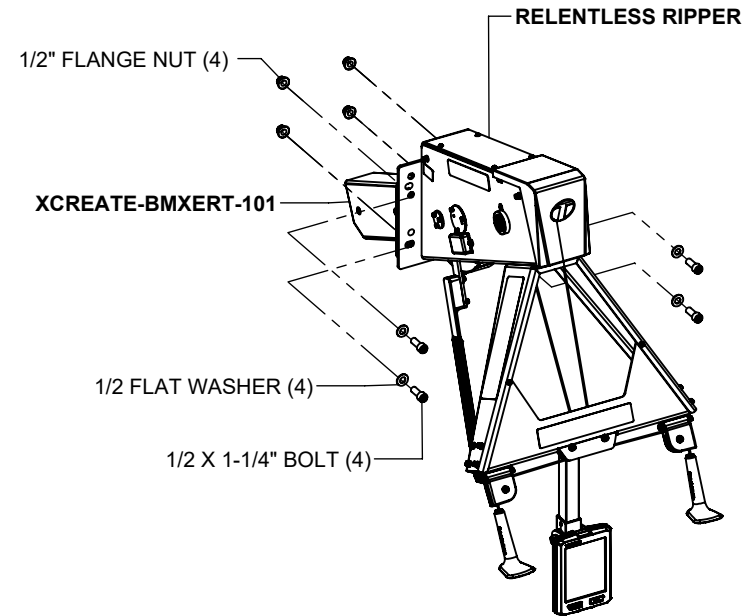
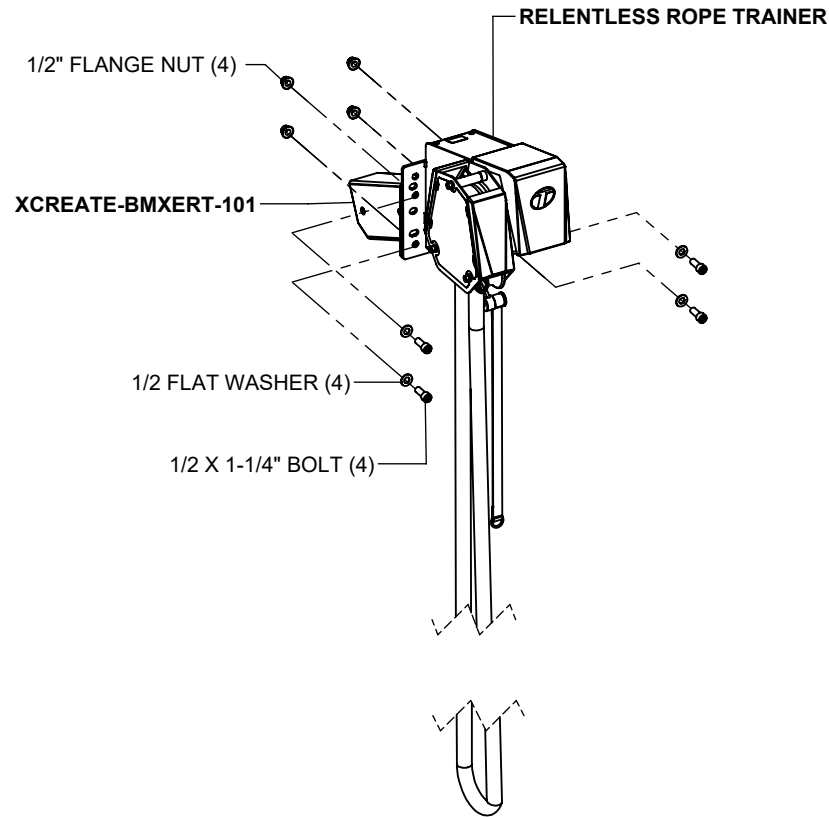

## **NOTE:**

**SECURELY** tighten all bolt connections in this step, Including the bolts from the previous step.

(\*\*) **HARDWARE COVERS CANNOT** be used in place of washers in this step.

**XCREATE** has been hidden for assembly clarity.

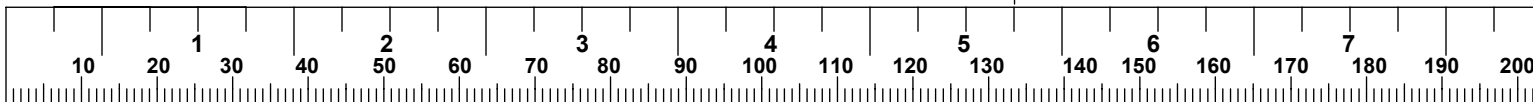

# XCREATE-SAM XCREATE SIDE ATTACHMENT MOUNT

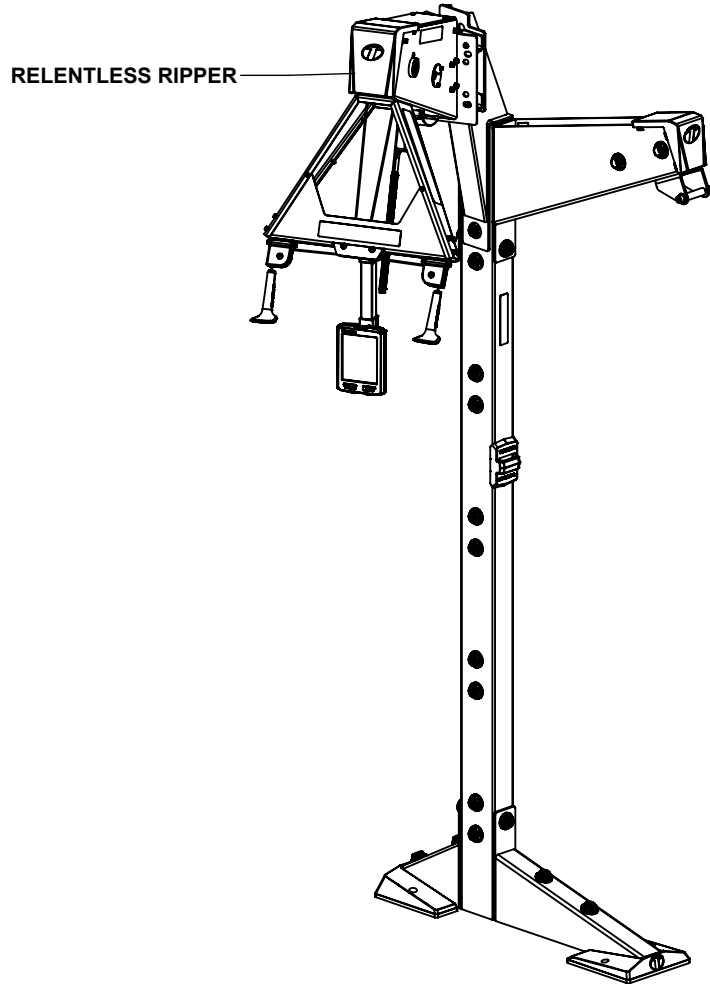

RELENTLESS RIPPER

XCREATE-SAM  
SIDE ATTACHMENT MOUNT

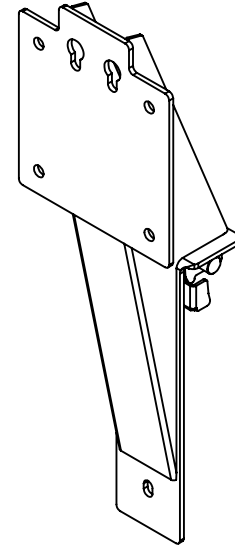

XCREATE-SUW  
SINGLE UNIT WEDGE

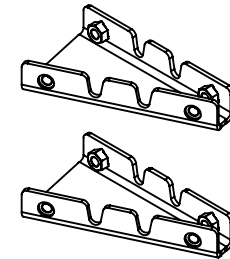

XCREATE-DUW  
DOUBLE UNIT WEDGE

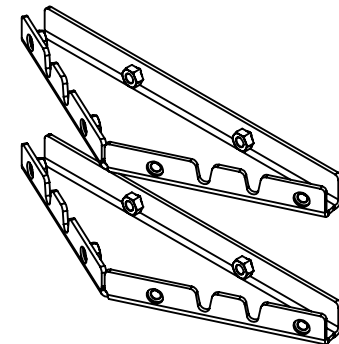

## NOTE:

The **Relentless Ripper** is shown, **Relentless Rope** may be assembled the same way.

Assembly instructions for the attachments above are included with the **XCREATE-SAM**.

The instructions can also be downloaded at <https://commercial.torquefitness.com/pages/assembly-manuals>

**XCREATE-4WAB**  
**4' WALL ANCHOR BRACKET**

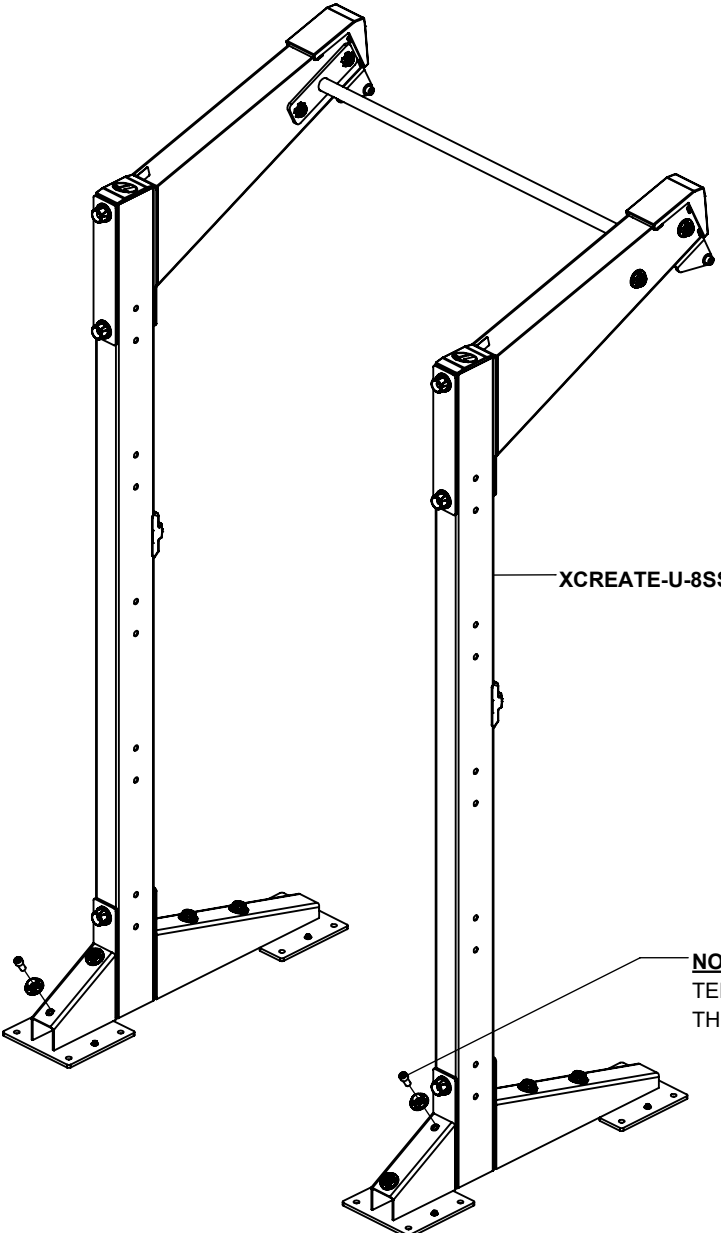

XCREATE-U-8SS

**NOTE:**  
TEMPORARILY REMOVE  
THIS BOLT AND WASHER (2)



**XCREATE-4WAB**  
**4' WALL ANCHOR BRACKET**

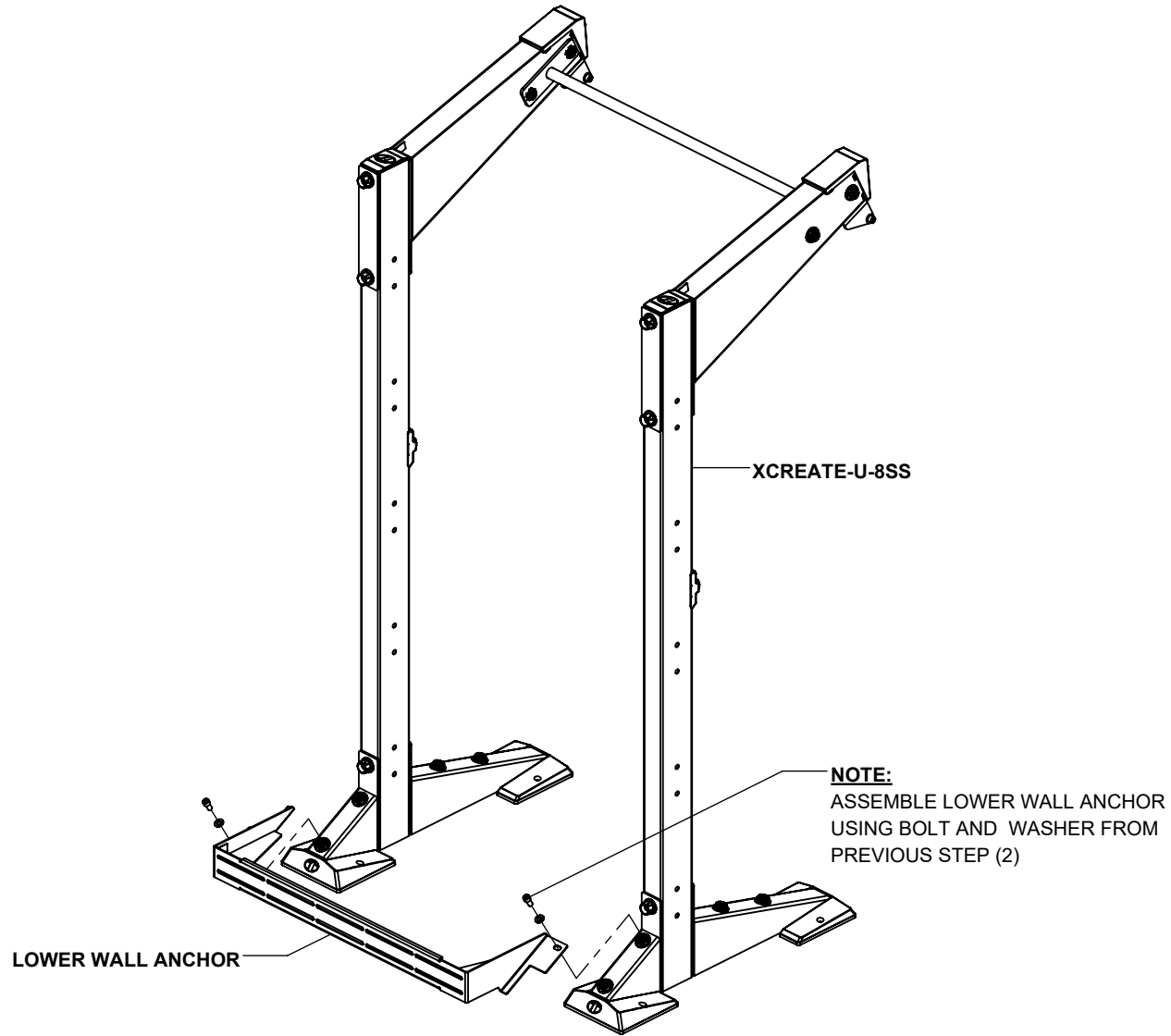

**NOTES:**

**SECURELY** assemble bolt connections in this step.

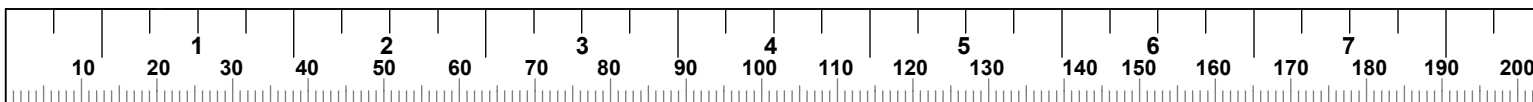

# **XCREATE-4WAB** **4' WALL ANCHOR BRACKET**

**NOTE:**  
LOOSEN BUT DO NOT  
REMOVE TOP BOLT

**NOTE:**  
REMOVE LOWER  
BOLT, ROTATE THE  
BACKING PLATE AND  
REASSEMBLE.  
SECURELY TIGHTEN.

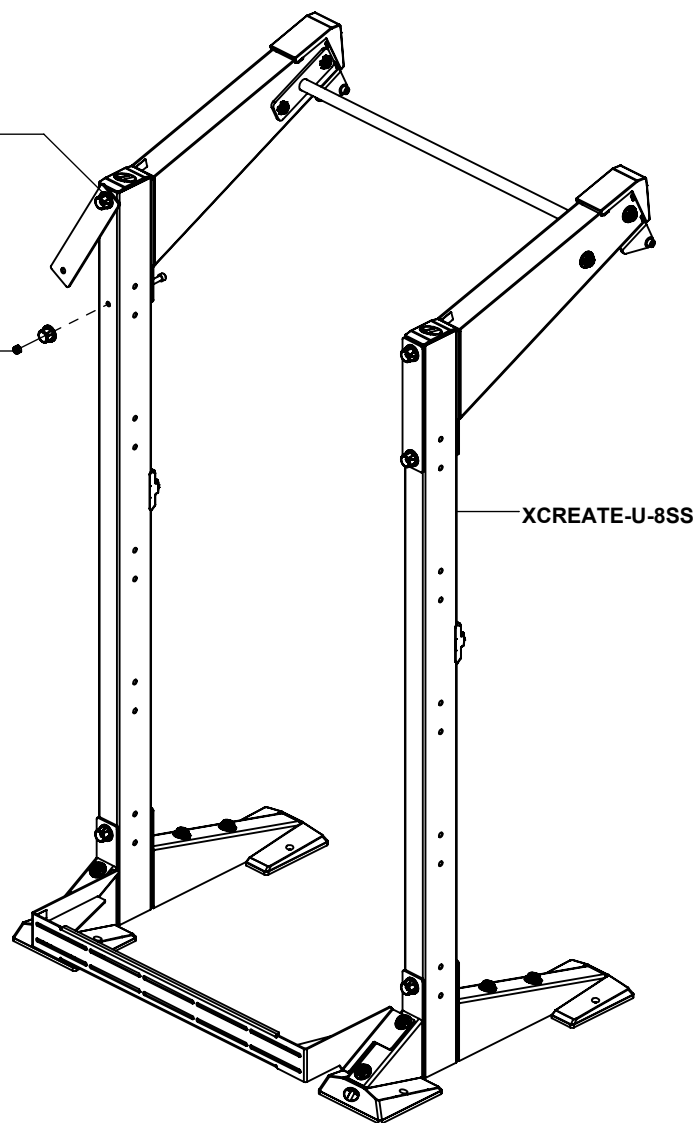

**NOTE:**  
REMOVE AND DISCARD  
BACKING PLATE

**NOTE:**  
TEMPORARILY REMOVE  
THIS BOLT, WASHER,  
HARDWARE COVER AND NUT

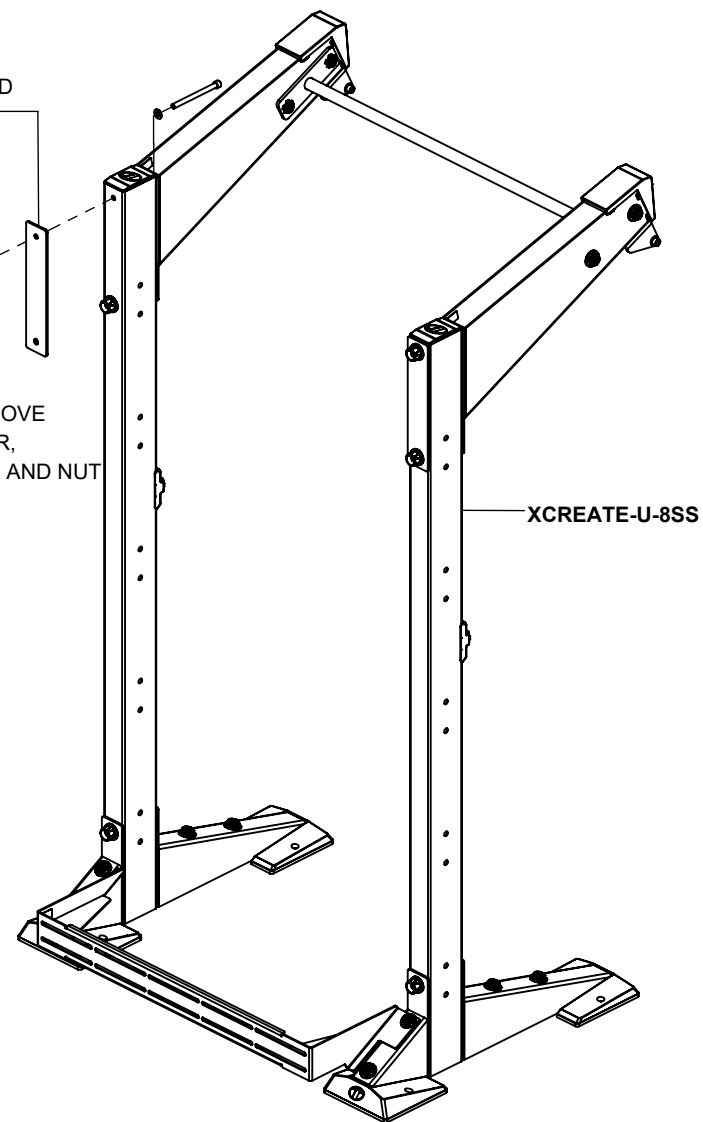

## **NOTES:**

**SECURELY** assemble bolt connections in this step.

**REPEAT THESE STEPS FOR BOTH UPRIGHTS.**

# XCREATE-4WAB 4' WALL ANCHOR BRACKET

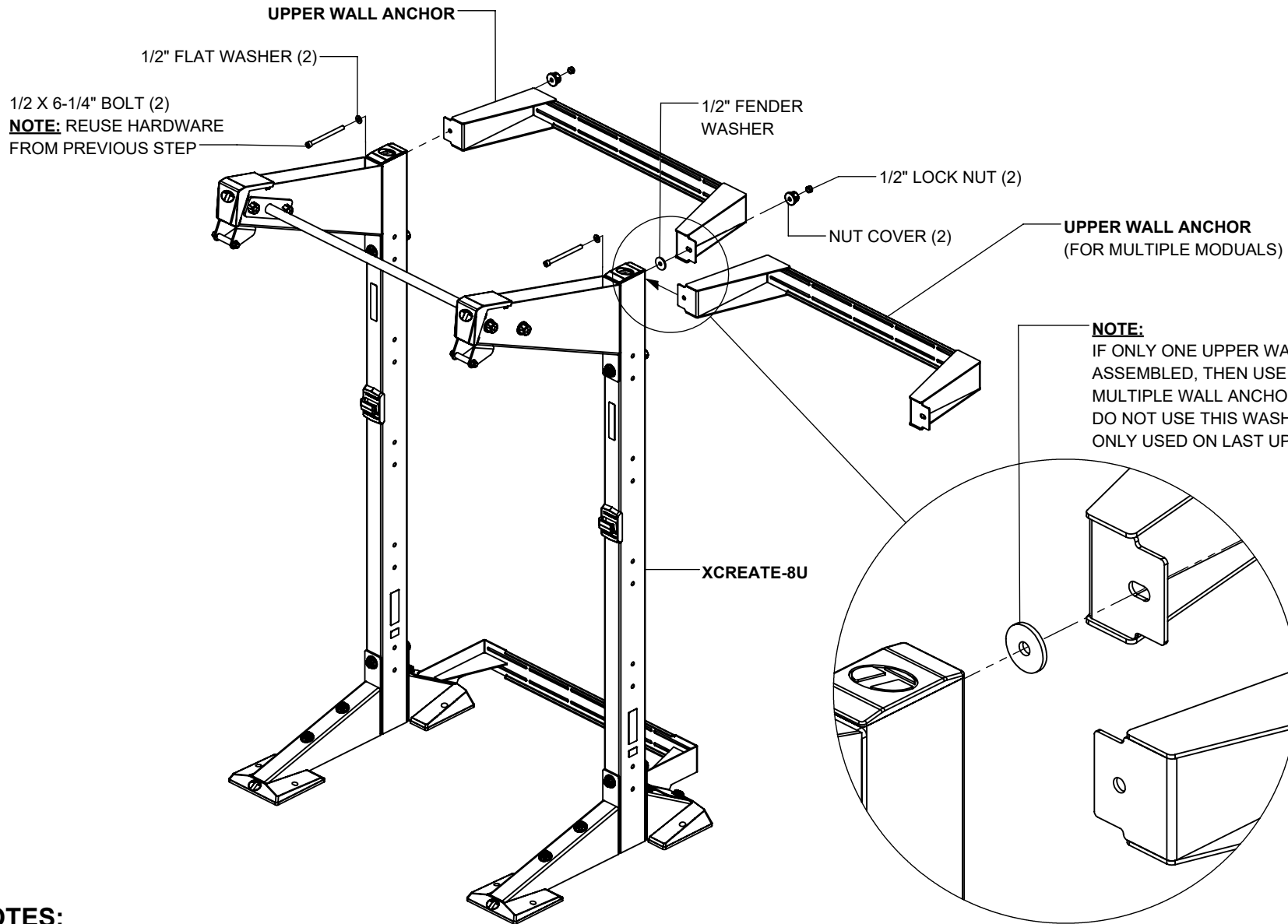

## NOTES:

**SECURELY** assemble bolt connections in this step.

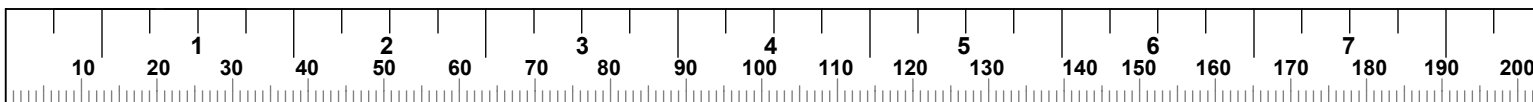

# XCREATE-4WAB 4' WALL ANCHOR BRACKET

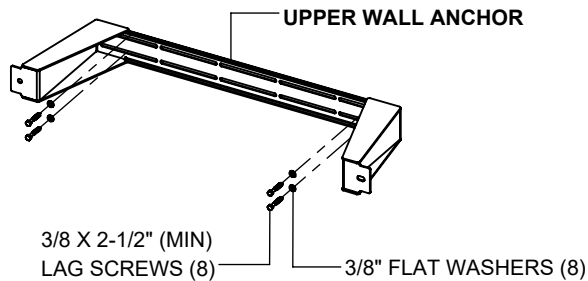

3/8 X 2-1/2" (MIN)  
LAG SCREWS (8)      3/8" FLAT WASHERS (8)

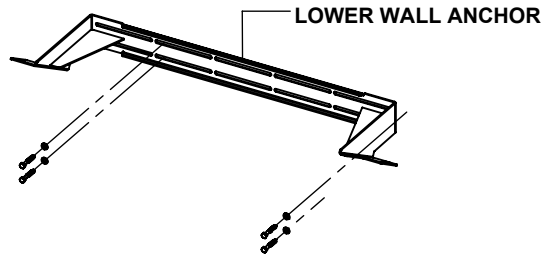

**NOTE:**  
XCREATE HAS BEEN HIDDEN  
TO SHOW ANCHORS CLEARLY

## NOTES:

The images above show the anchoring hardware used for attaching to typical walls with wood studs spaced 16" on center. The anchors used will depend on the wall construction. **NOTE: At least four anchoring locations must be used in each part.** The pull-out strength of the anchoring bolts used must be greater than or equal to 200 lbs. (91 kg)

**SECURELY** tighten bolt connections in this step.

**WARNING:**  
**THE UPPER WALL ANCHOR MUST BE ANCHORED TO THE WALL USING FOUR WALL ANCHORS SUITABLE FOR THAT PARTICULAR WALL CONSTRUCTION.**

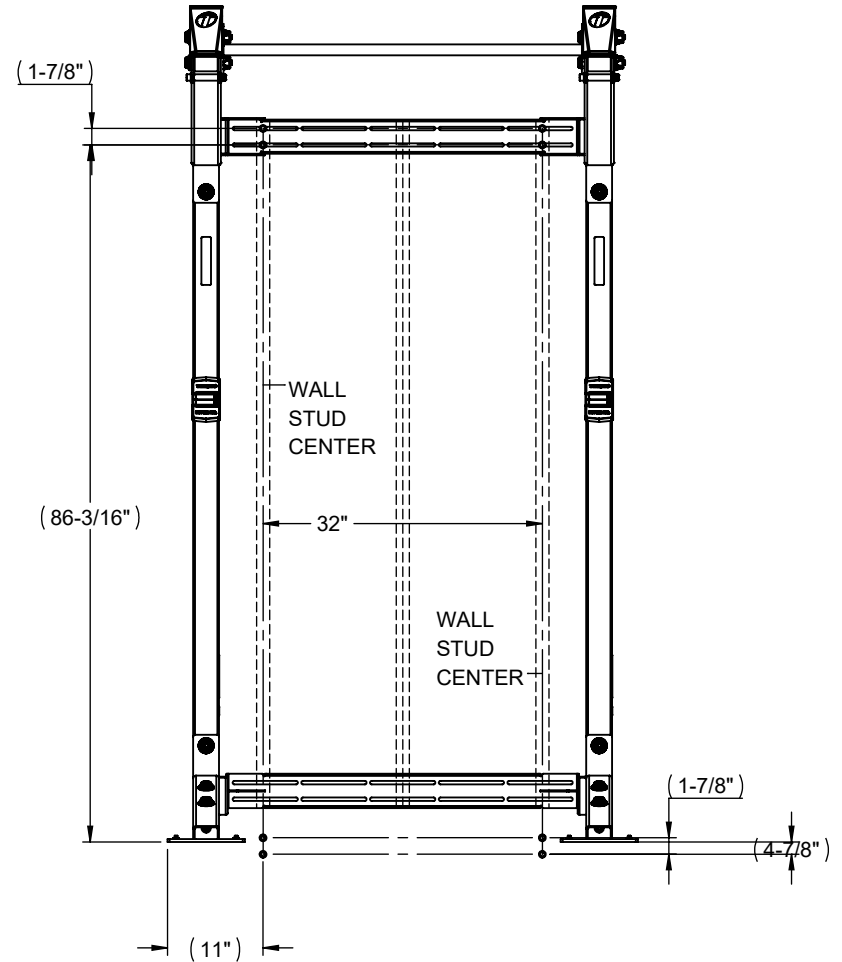

**WARNING:**  
**THE LOWER WALL ANCHOR MUST BE ANCHORED TO THE WALL USING FOUR WALL ANCHORS SUITABLE FOR THAT PARTICULAR WALL CONSTRUCTION.**

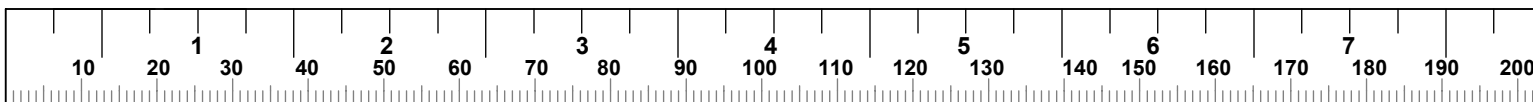

**XCREATE-4CWS  
4' COUNTERWEIGHT SUPPORT**

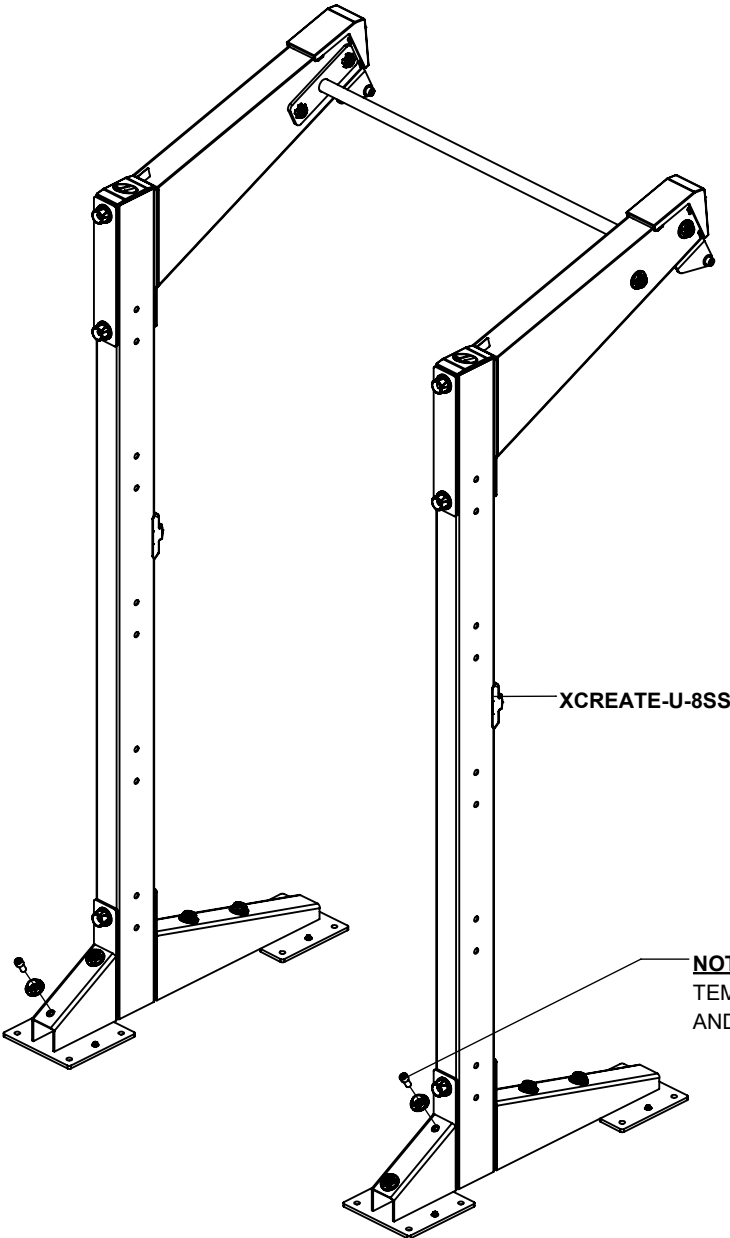

XCREATE-U-8SS

**NOTE:**  
TEMPORARILY REMOVE BOLTS  
AND HARDWARE COVERS (2)

# **XCREATE-4CWS** **4' COUNTERWEIGHT SUPPORT**

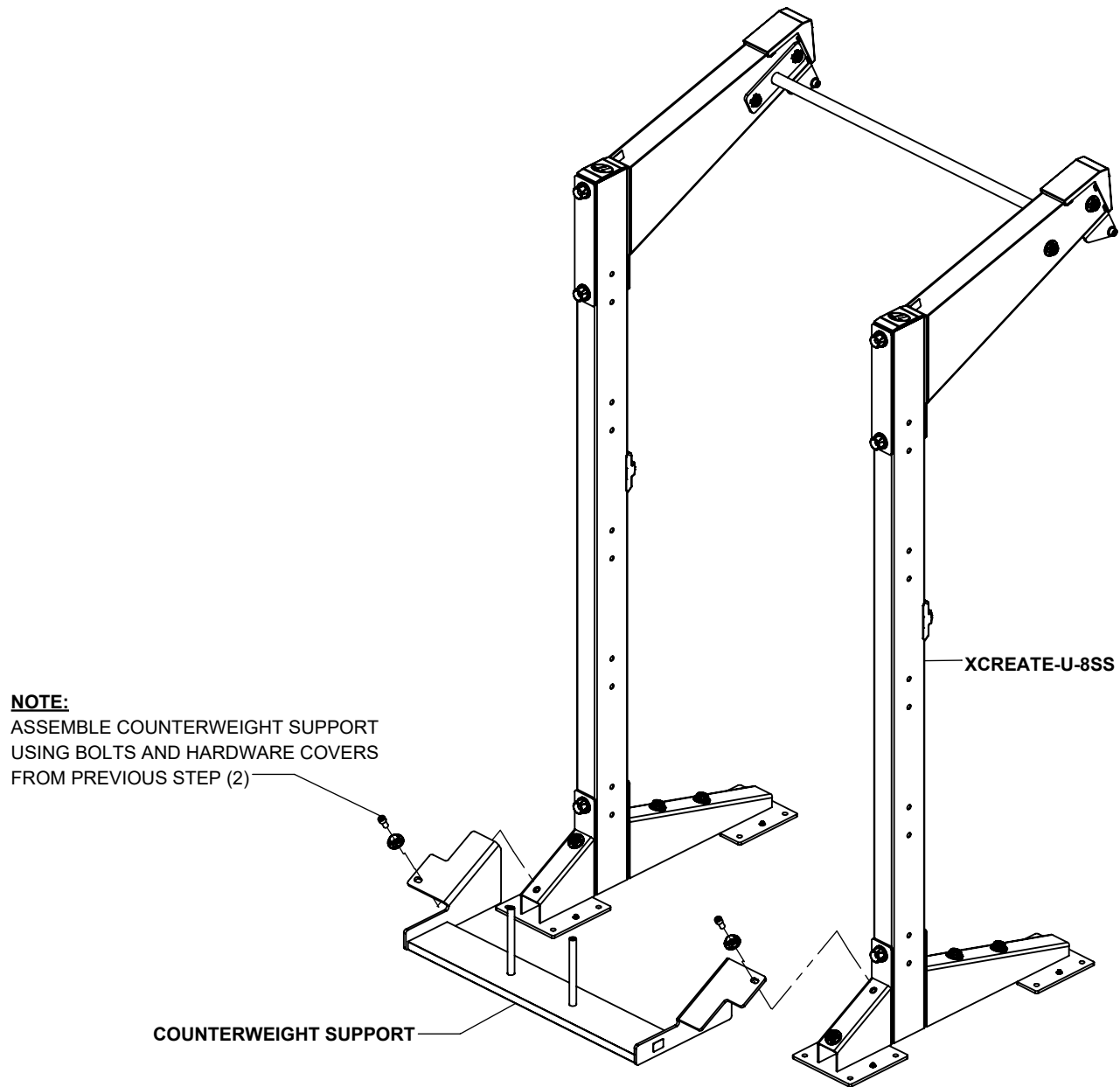

## **NOTES:**

**SECURELY** assemble bolt connections in this step.

The **XCREATE-U-7SS** is assembled the exact same way.

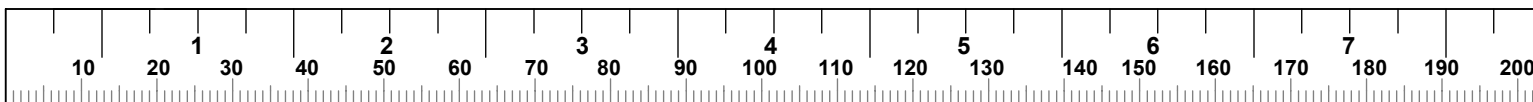

**XCREATE-4CWS**  
**4' COUNTERWEIGHT SUPPORT**

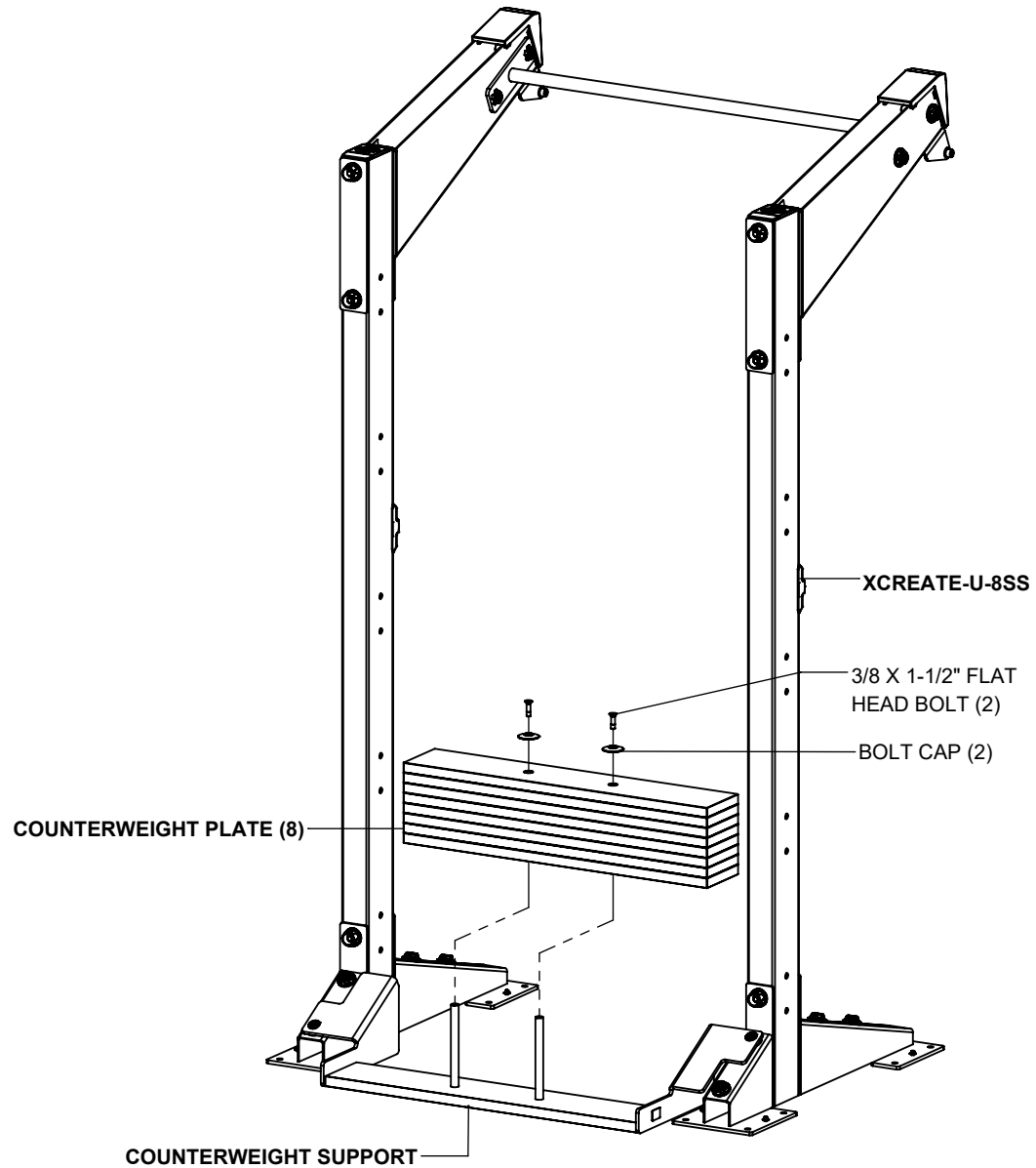

**NOTES:**

**SECURELY** assemble bolt connections in this step.

The **XCREATE-U-7SS** is assembled the exact same way.

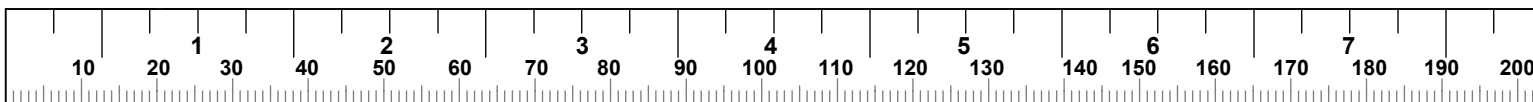

**XCREATE-6CWS**  
**6' COUNTERWEIGHT SUPPORT**

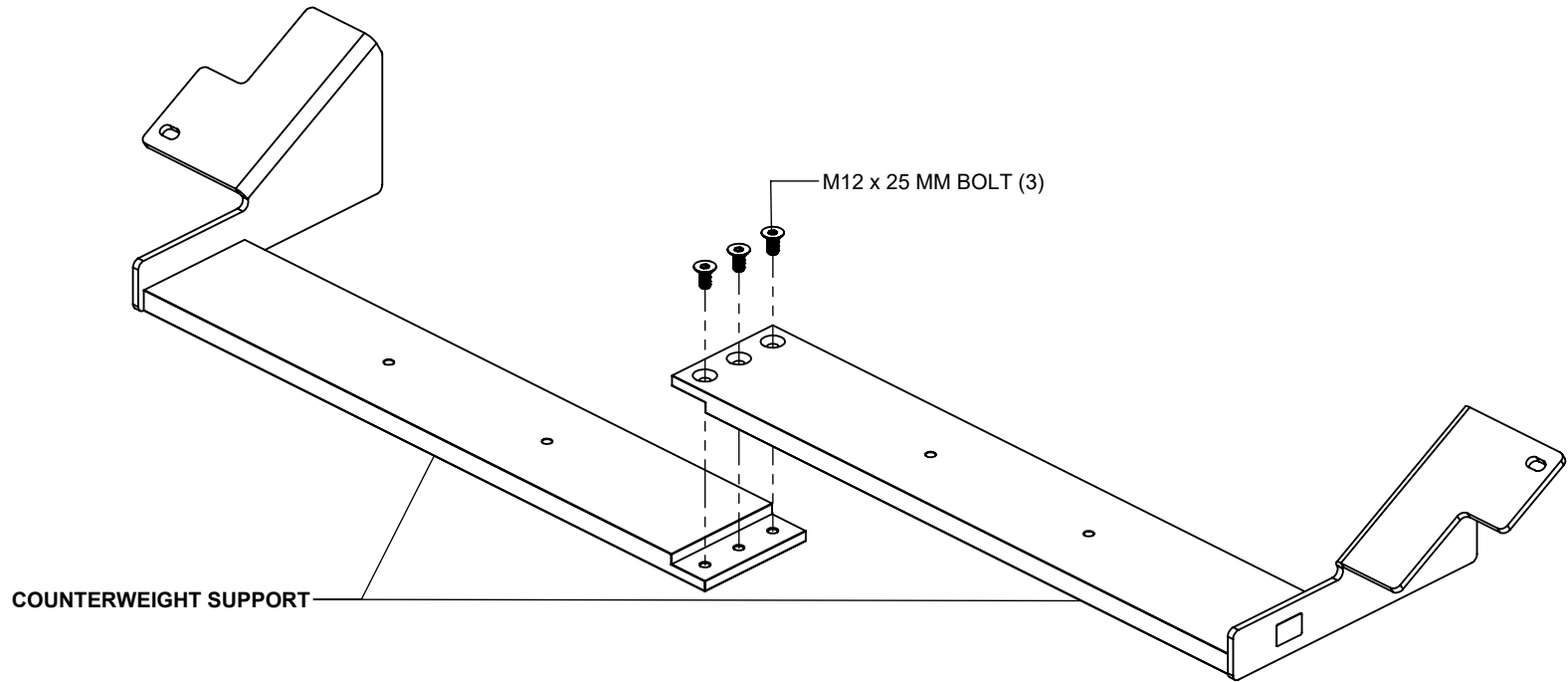

**NOTES:**

**SECURELY** assemble bolt connections in this step.

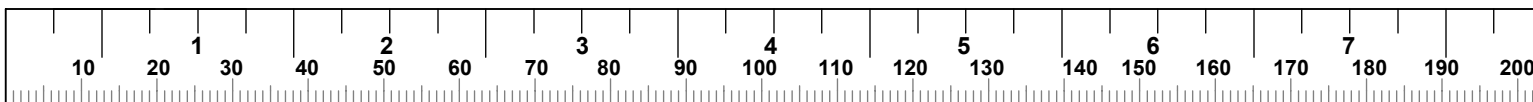



**XCREATE-6CWS  
6' COUNTERWEIGHT SUPPORT**

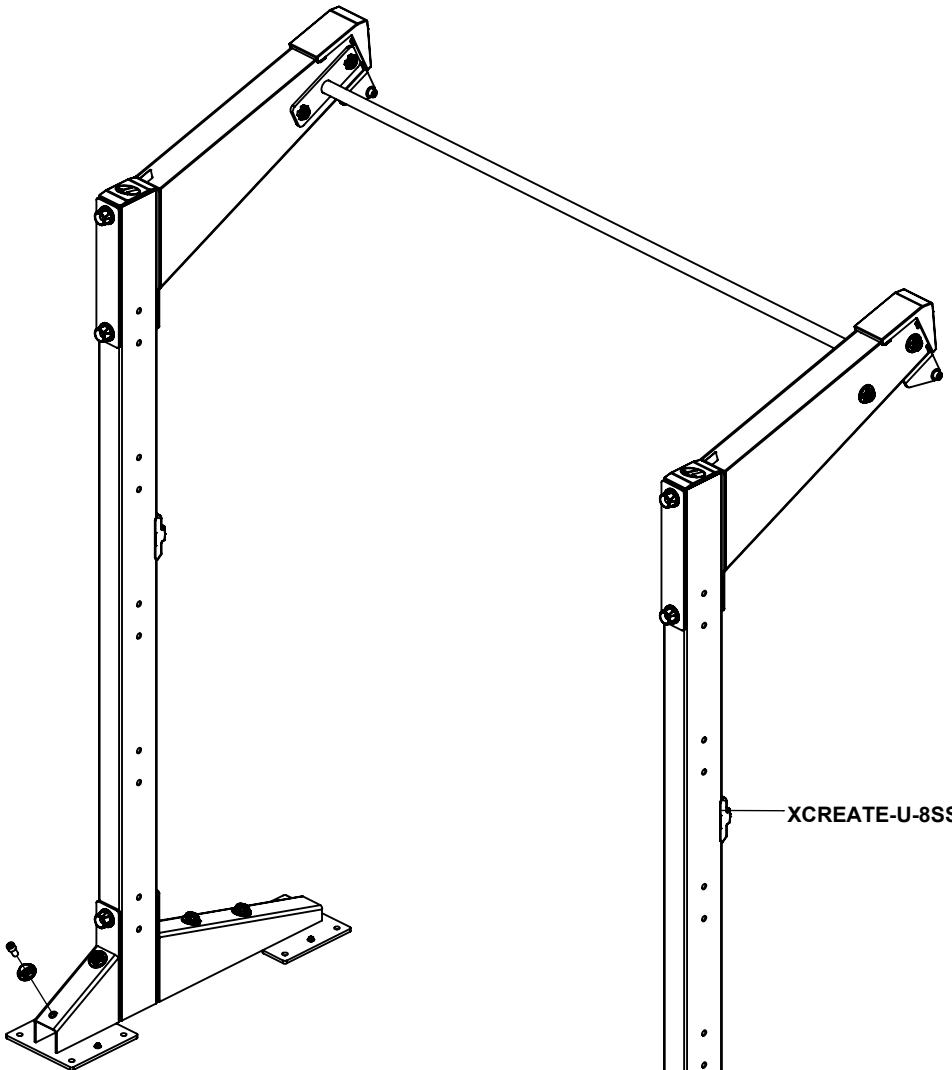

XCREATE-U-8SS

**NOTE:**  
TEMPORARILY REMOVE BOLTS  
AND HARDWARE COVERS (2)

# **XCREATE-6CWS** **6' COUNTERWEIGHT SUPPORT**

**NOTE:**

ASSEMBLE COUNTERWEIGHT SUPPORT  
USING BOLTS AND HARDWARE COVERS  
FROM PREVIOUS STEP (2)

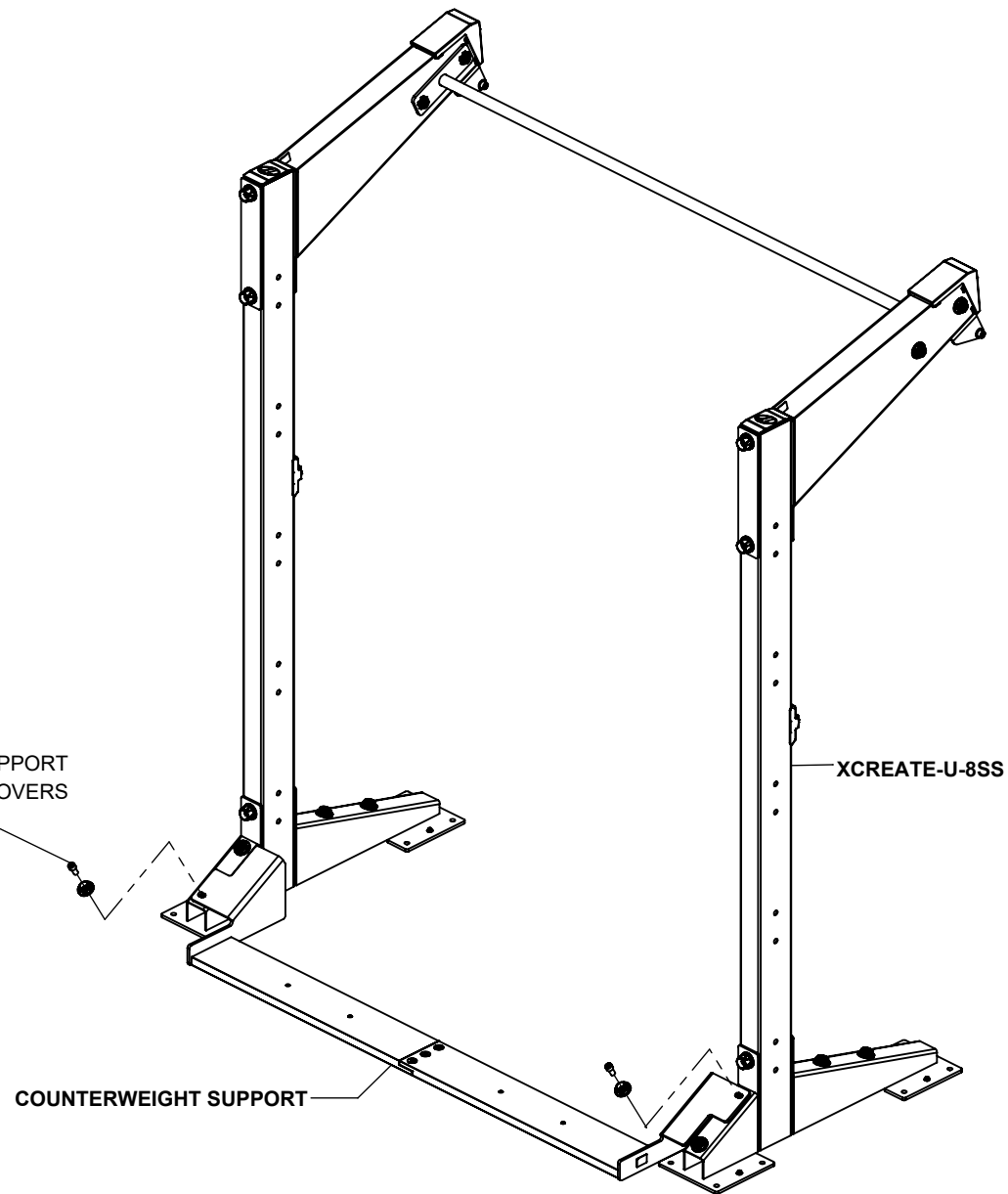

**NOTES:**

**SECURELY** assemble bolt connections in this step.

The **XCREATE-U-7SS** is assembled the exact same way.

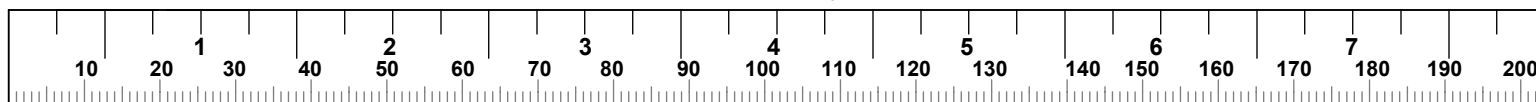

**XCREATE-6CWS**  
**6' COUNTERWEIGHT SUPPORT**

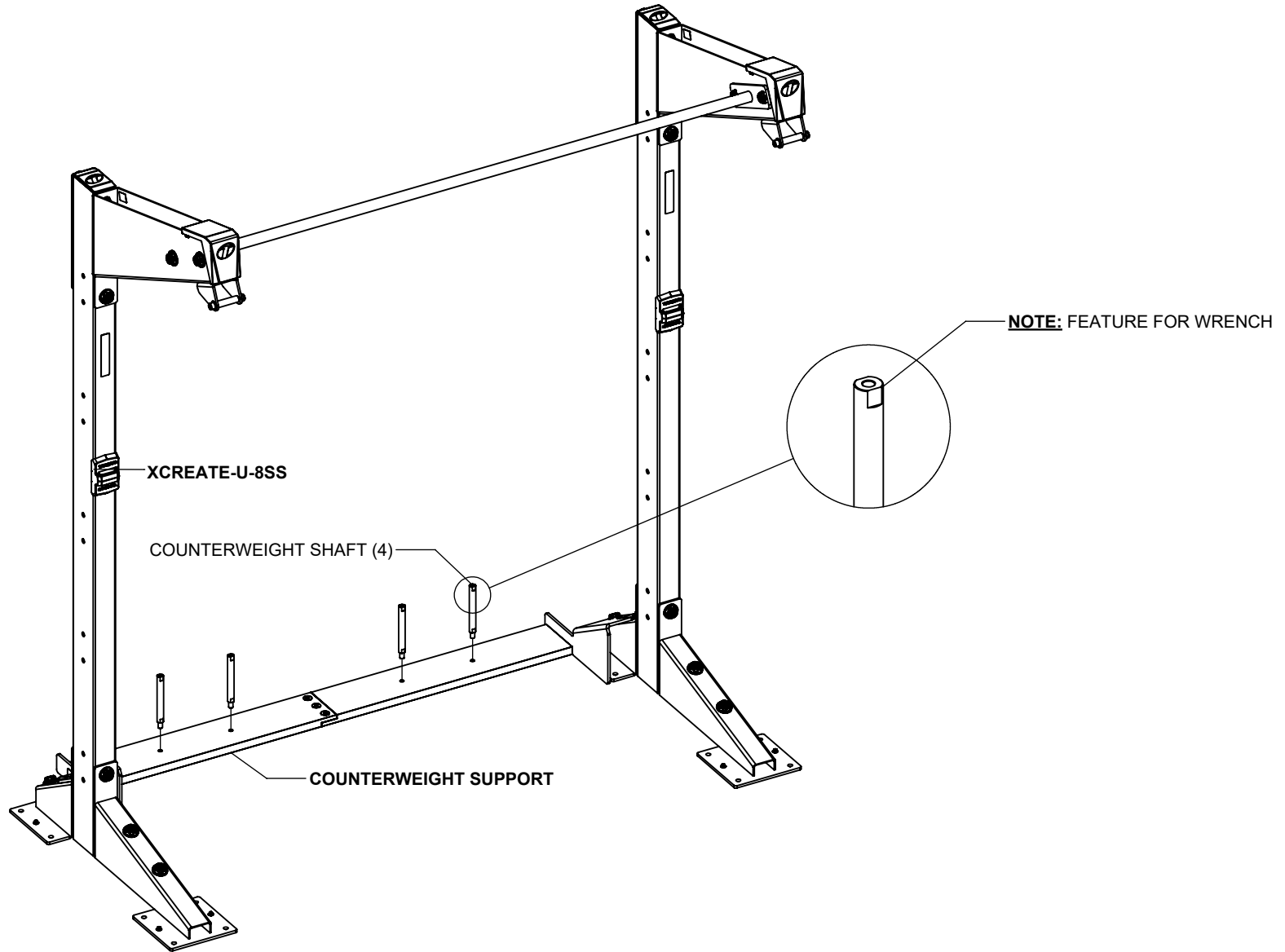

**NOTES:**

**SECURELY** assemble bolt connections in this step.

The **XCREATE-U-7SS** is assembled the exact same way.

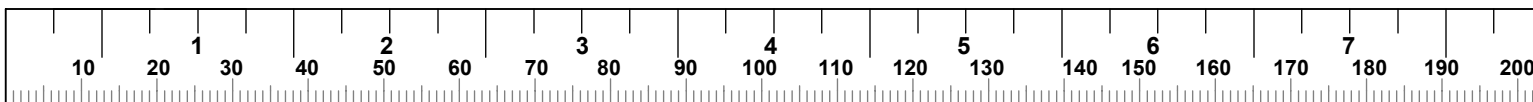

**XCREATE-6CWS**  
**6' COUNTERWEIGHT SUPPORT**

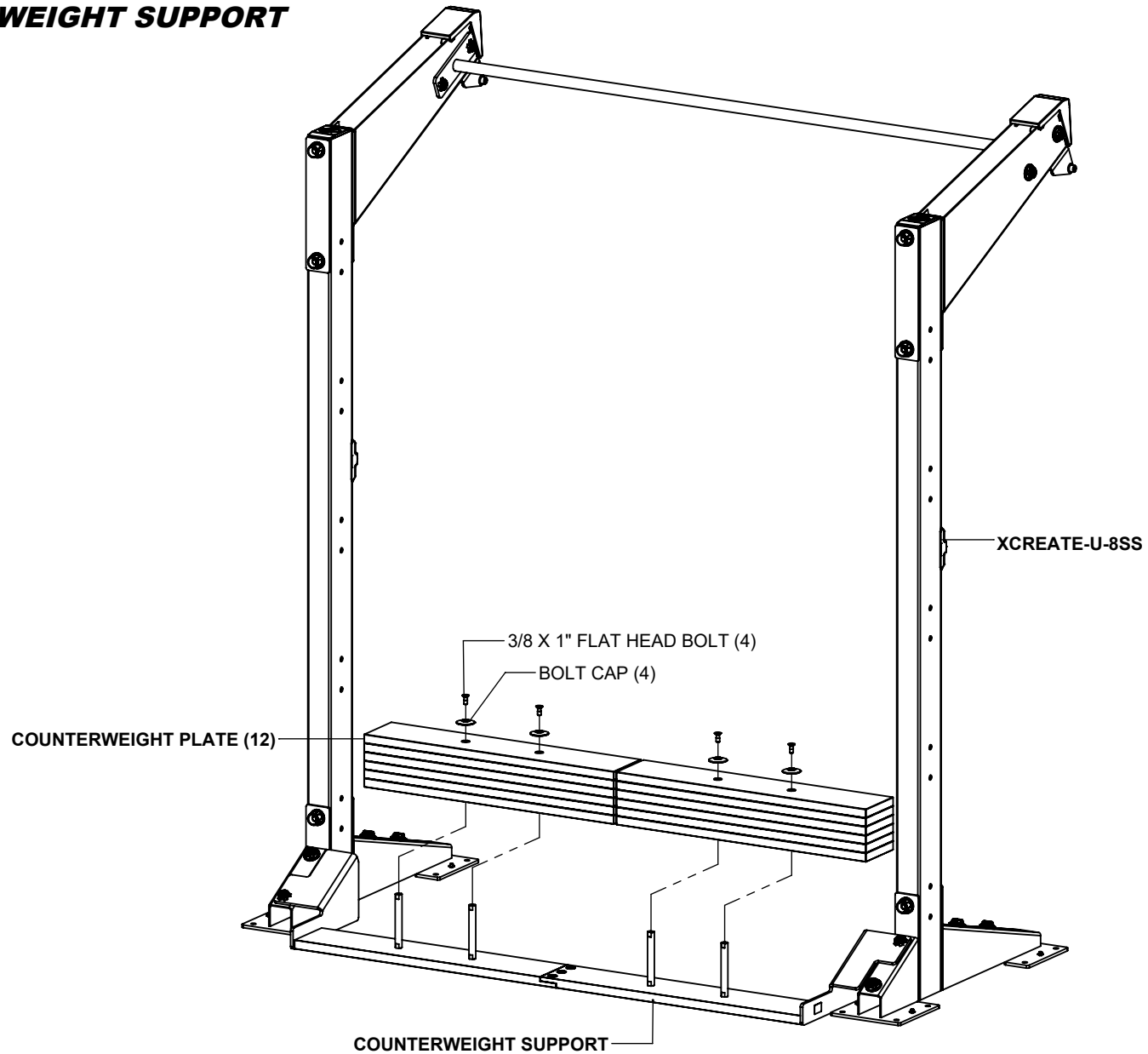

**NOTES:**

**SECURELY** assemble bolt connections in this step.

The **XCREATE-U-7SS** is assembled the exact same way.

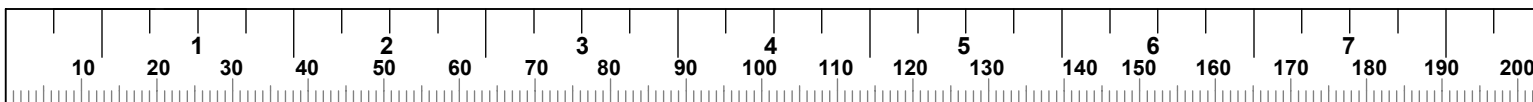

**XCREATE-OR  
OUTRIGGER**

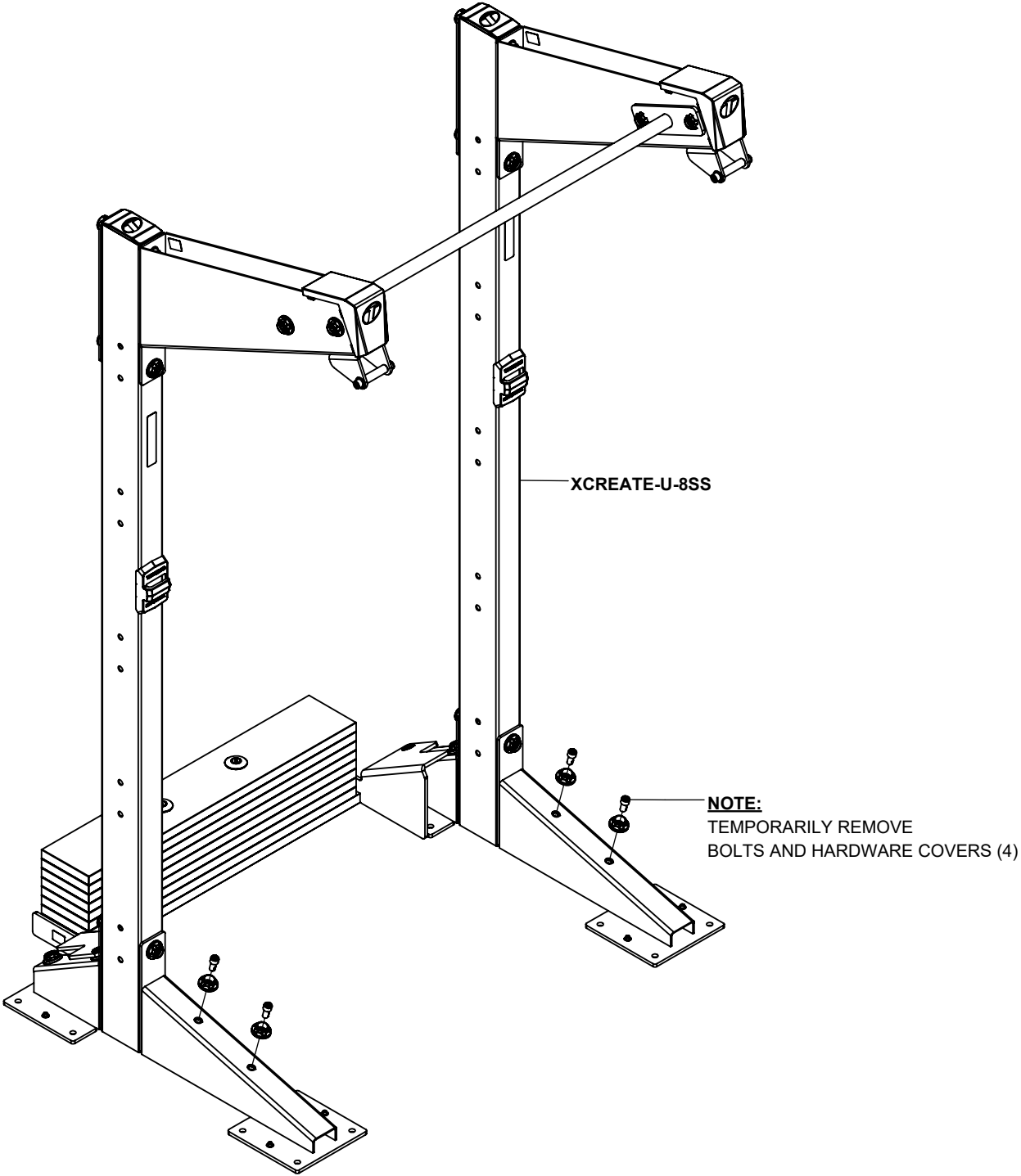

# XCREATE-OR OUTRIGGER

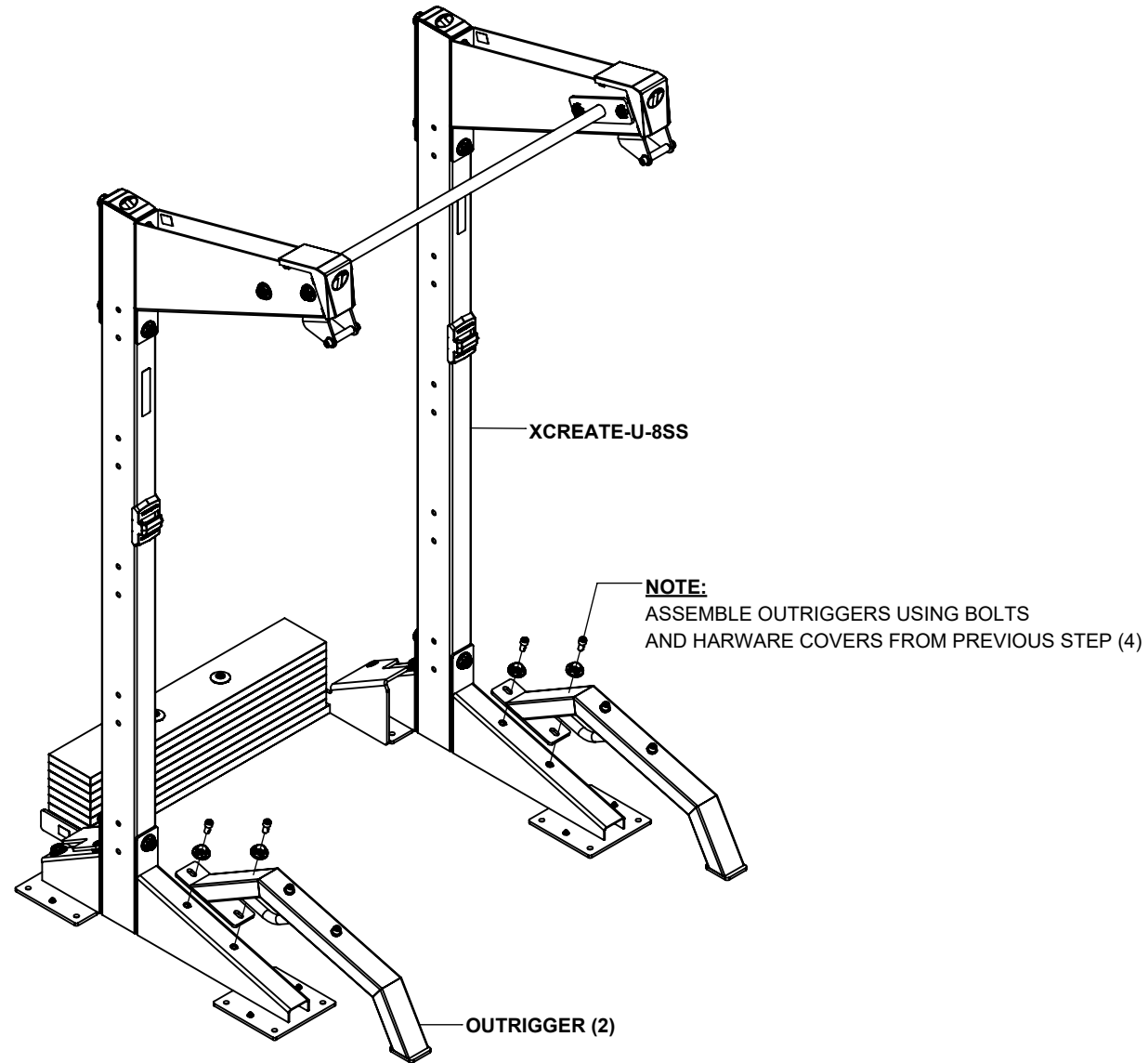

## **NOTES:**

**SECURELY** assemble bolt connections in this step.

The **XCREATE-U-7SS** is assembled the exact same way.

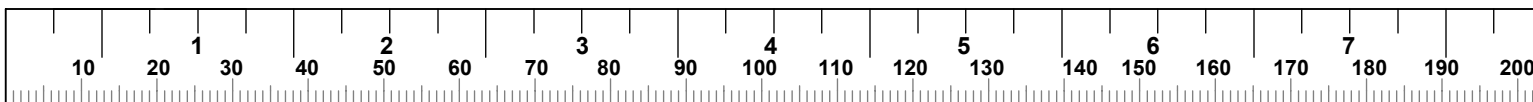

**XCREATE-SA-BOSU  
BOSU STORAGE ATTACHMENT**

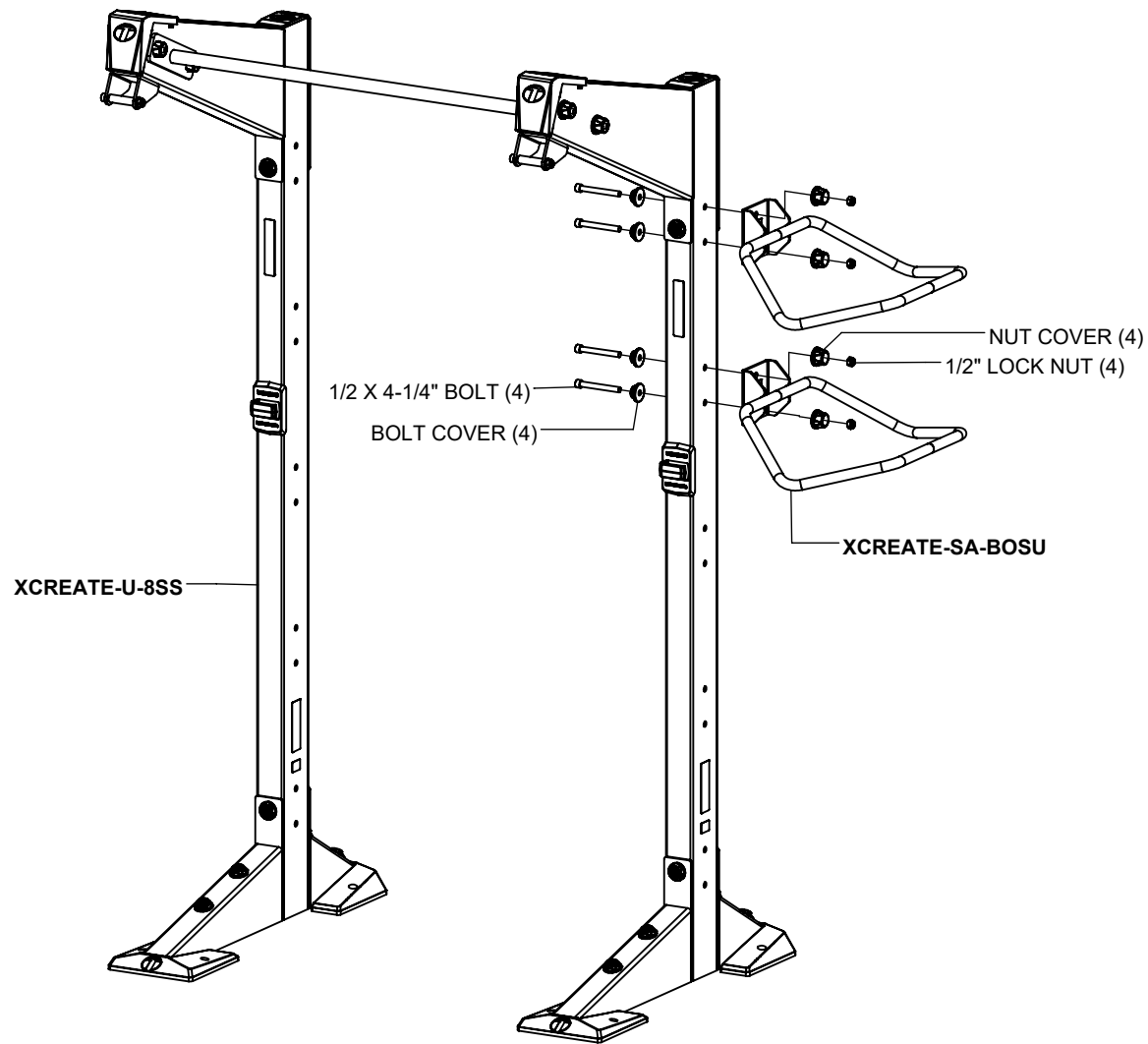

**NOTES:**

**SECURELY** tighten all bolt connections in this step.

The **XCREATE-U-7SS** is assembled the exact same way.

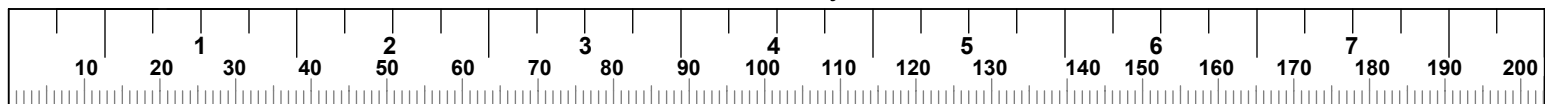

**XCREATE-FRS6-8  
FOAM ROLLER STORAGE ATTACHMENT**

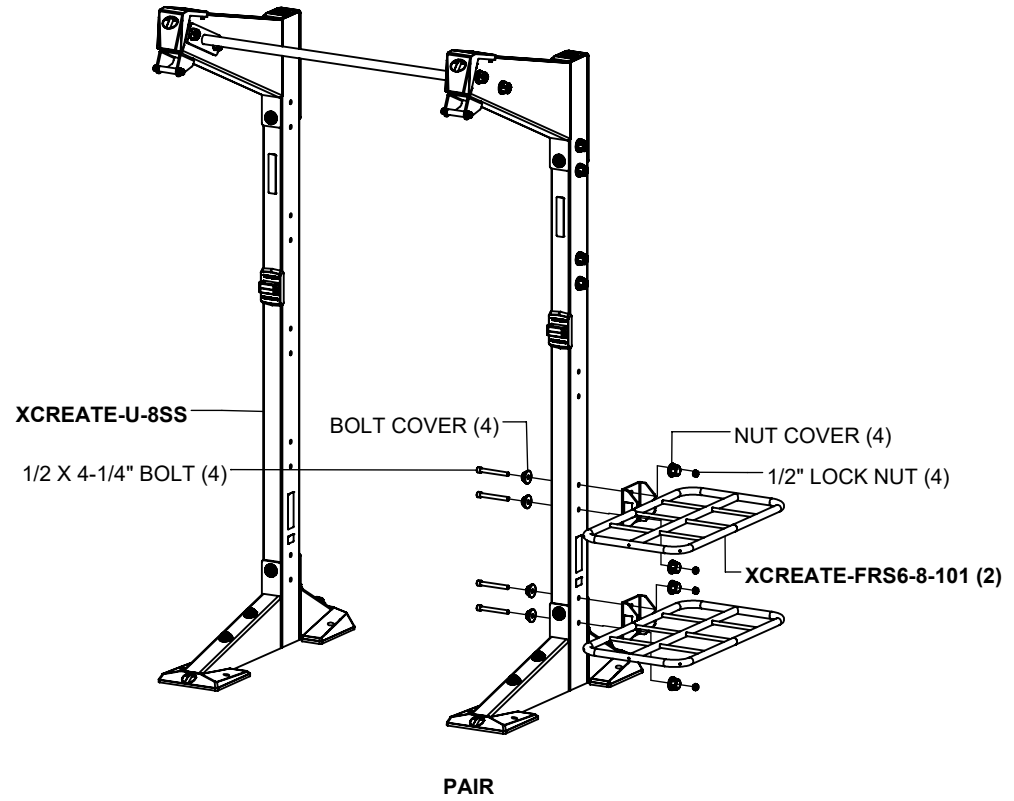
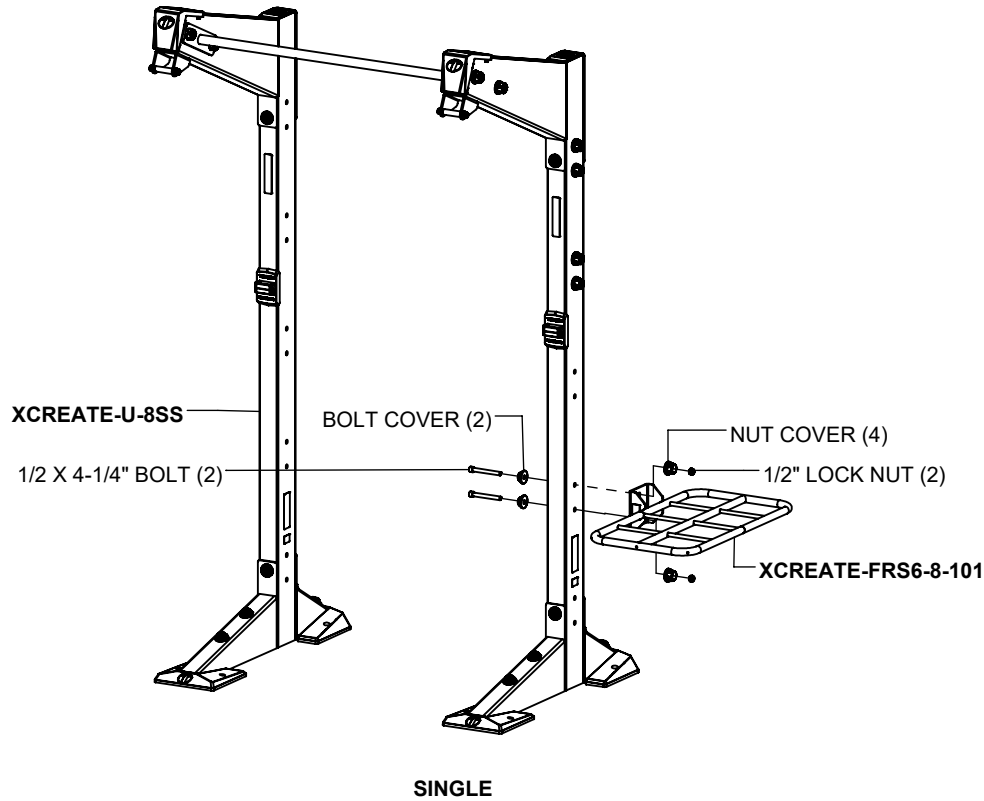

**NOTES:**

Assembly steps show a single and pair. For additional foam roller stability a pair is recommended.

**LEVEL ATTACHMENT AND SECURELY** tighten all bolt connections in this step.

The **XCREATE-U-7SS** is assembled the exact same way.

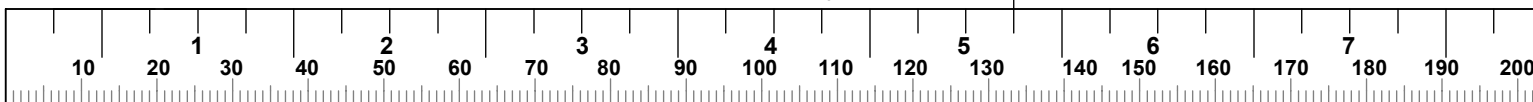



# **XCREATE-FRS6-8 FOAM ROLLER STORAGE ATTACHMENT**

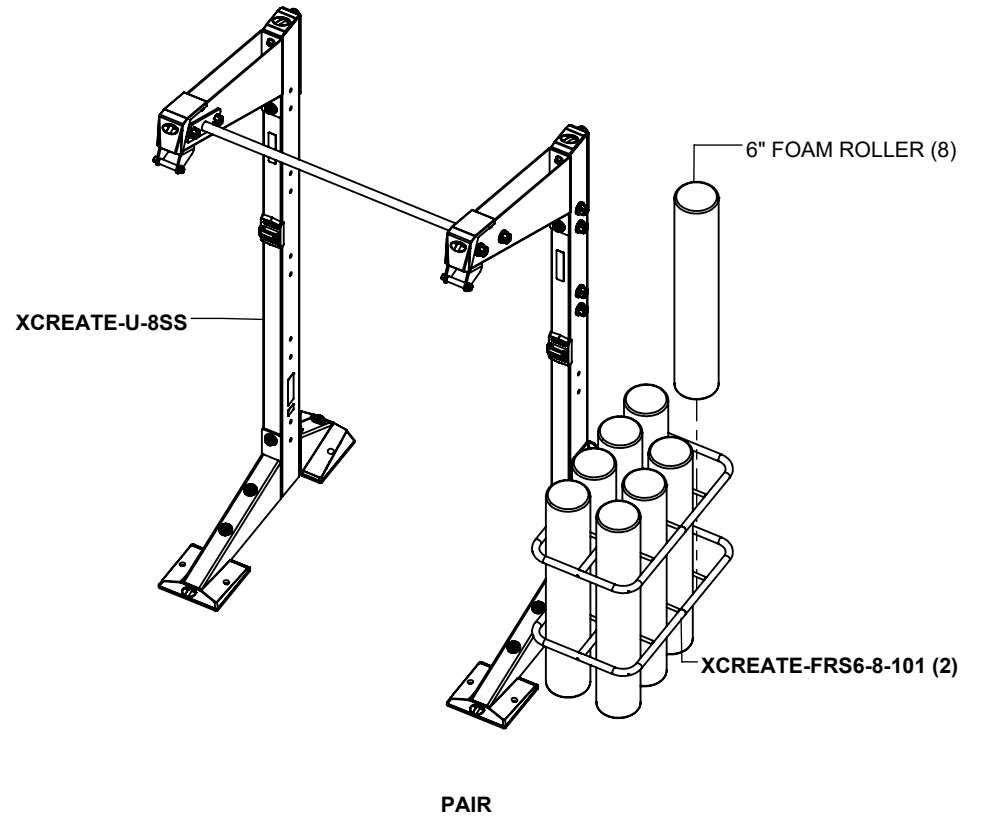
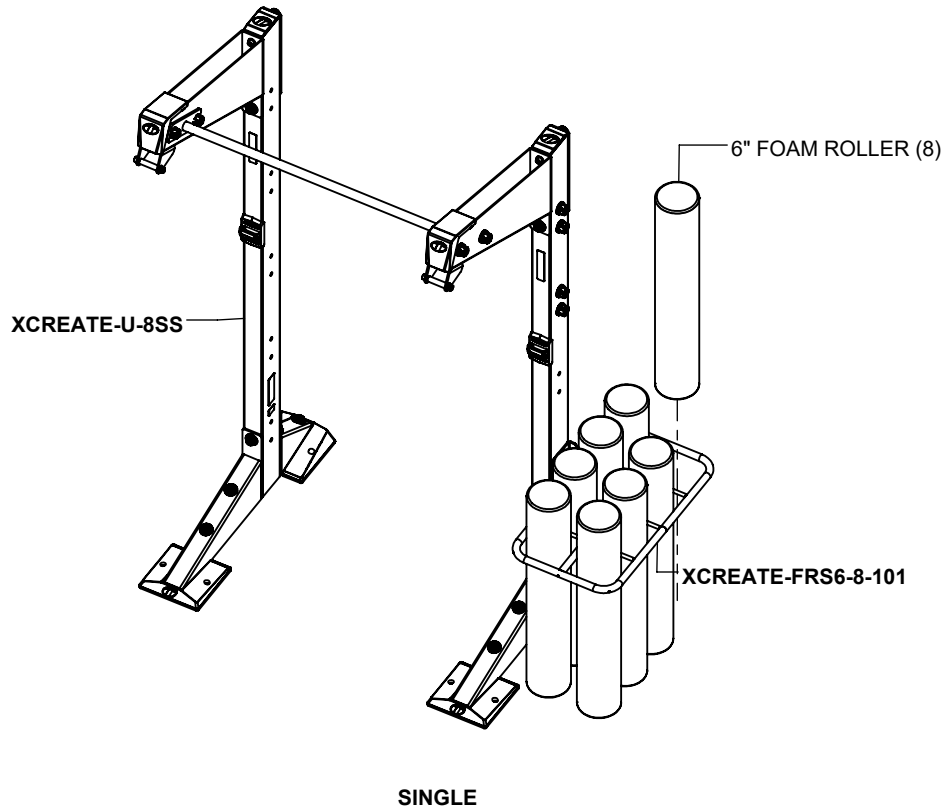

## **NOTES:**

Assembly steps show a single and pair. For additional foam roller stability a pair is recommended.

**LEVEL ATTACHMENT AND SECURELY** tighten all bolt connections in this step.

The **XCREATE-U-7SS** is assembled the exact same way.

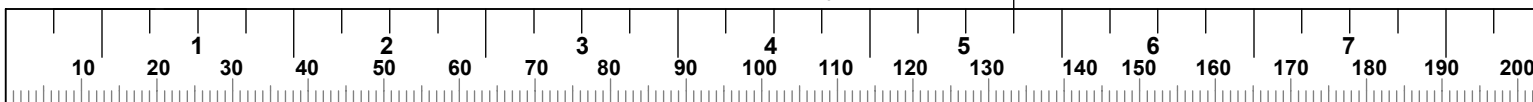

## STALL BAR DIP ATTACHMENT

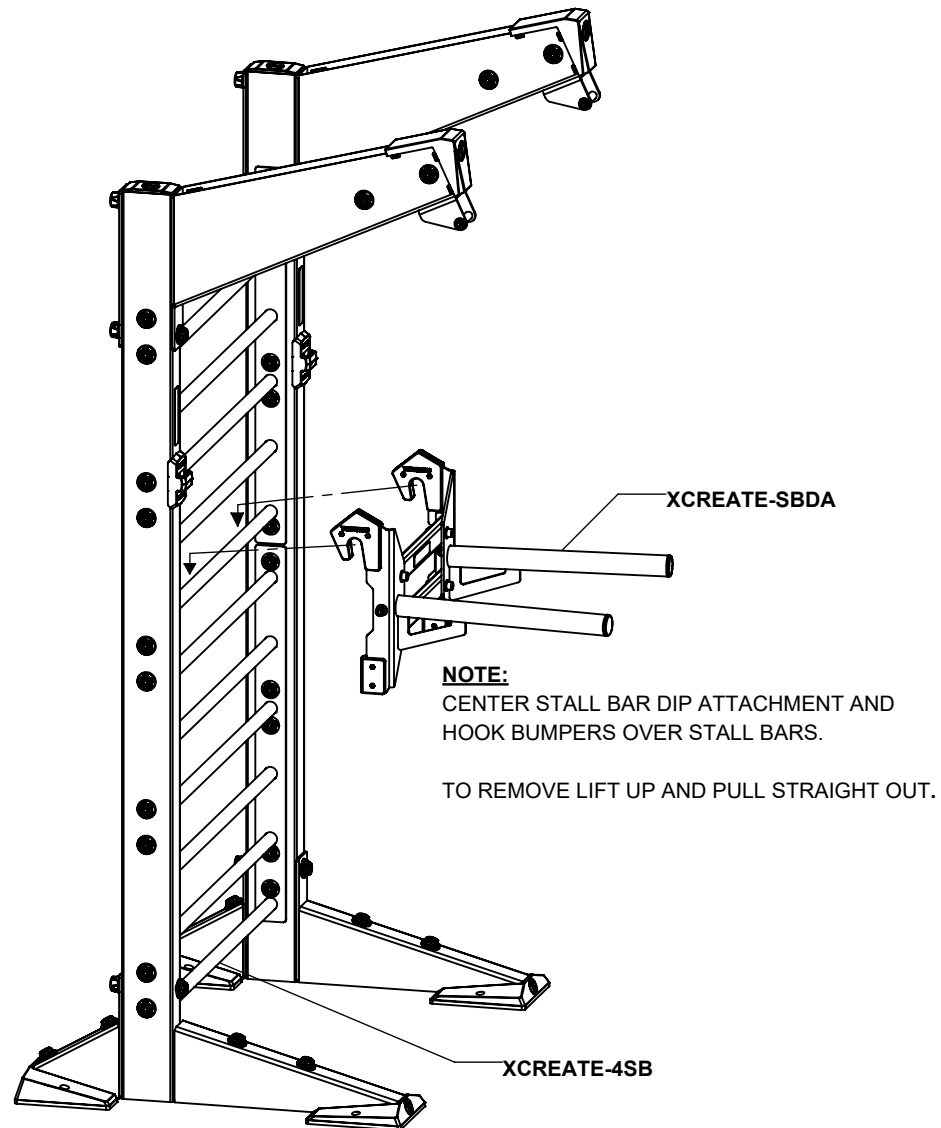

### **NOTES:**

The XCREATE 4' stall bar module is required in this step. For module assembly see previous steps.

**BCSA**  
**BAR CATCH STORAGE ATTACHMENT**

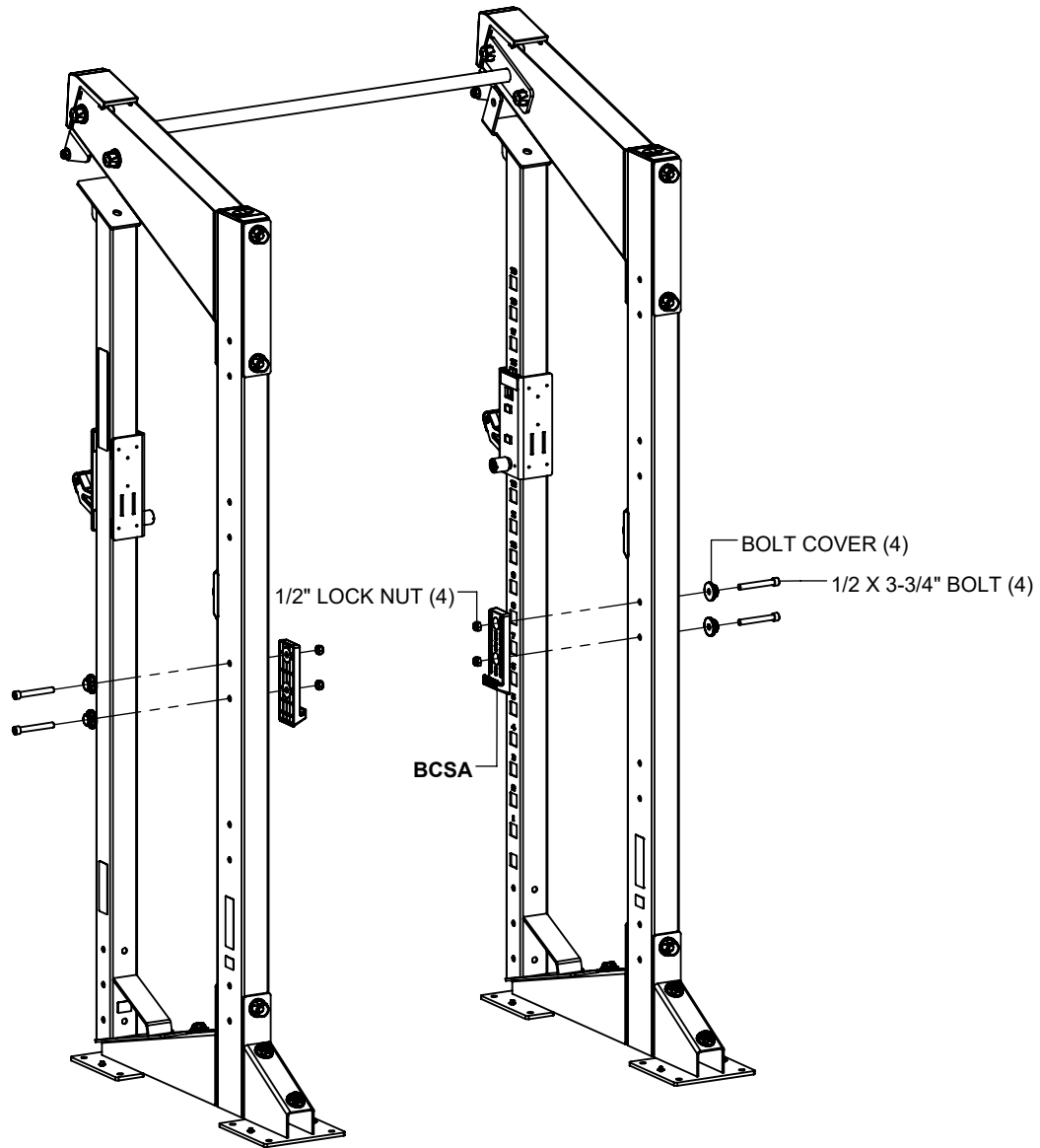

**NOTES:**

**SECURELY** tighten all bolt connections in this step.

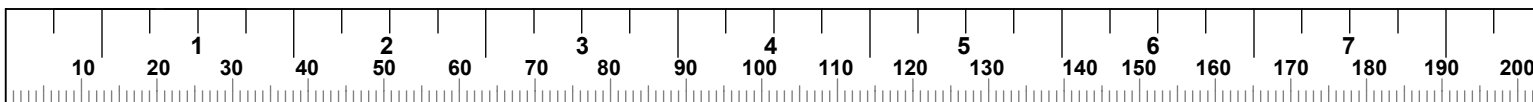

**BCSA**  
**BAR CATCH STORAGE ATTACHMENT**

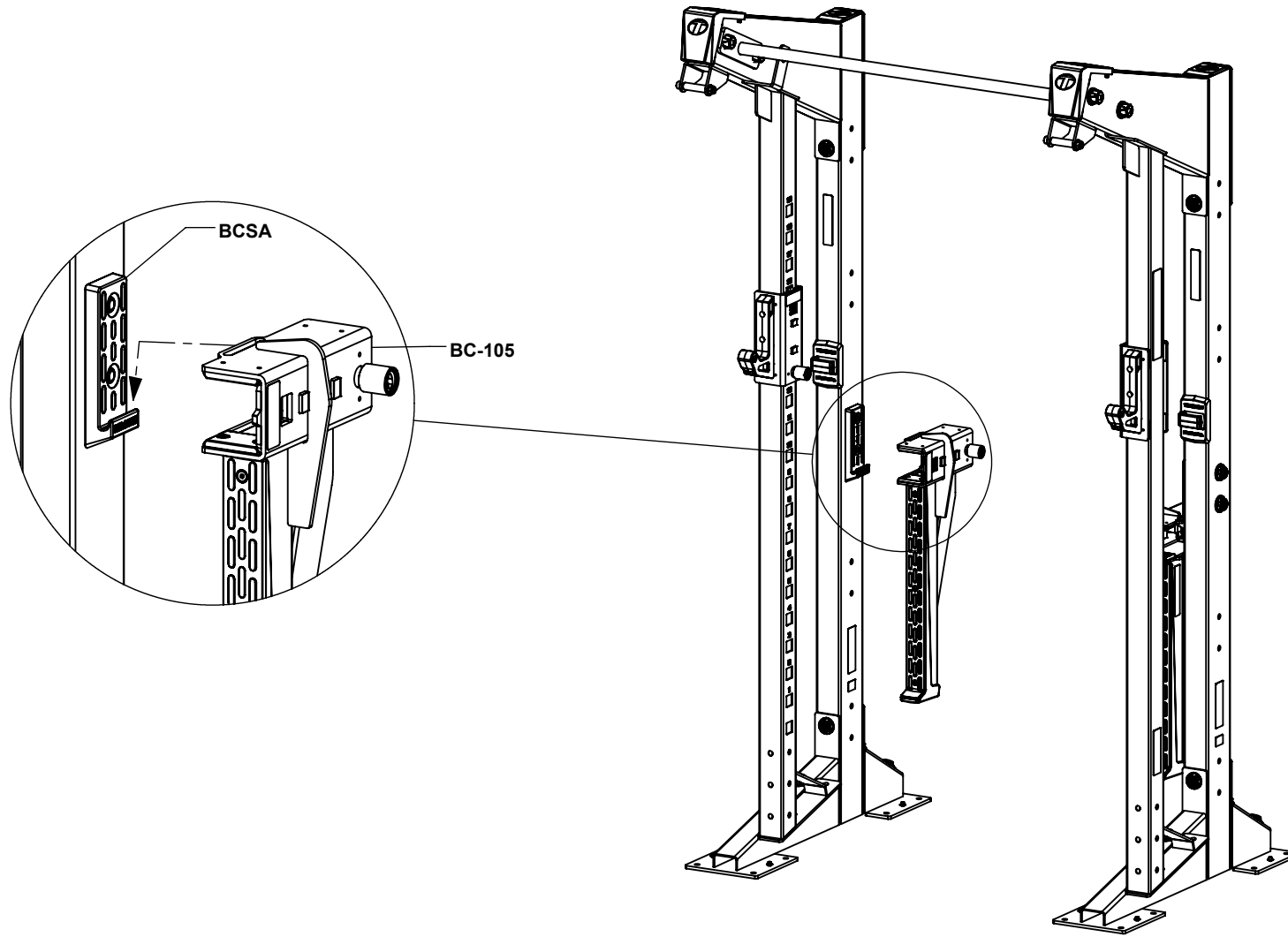

**XCREATE-HMSC**  
**MAGNETIC SUSPENSION CLIP**

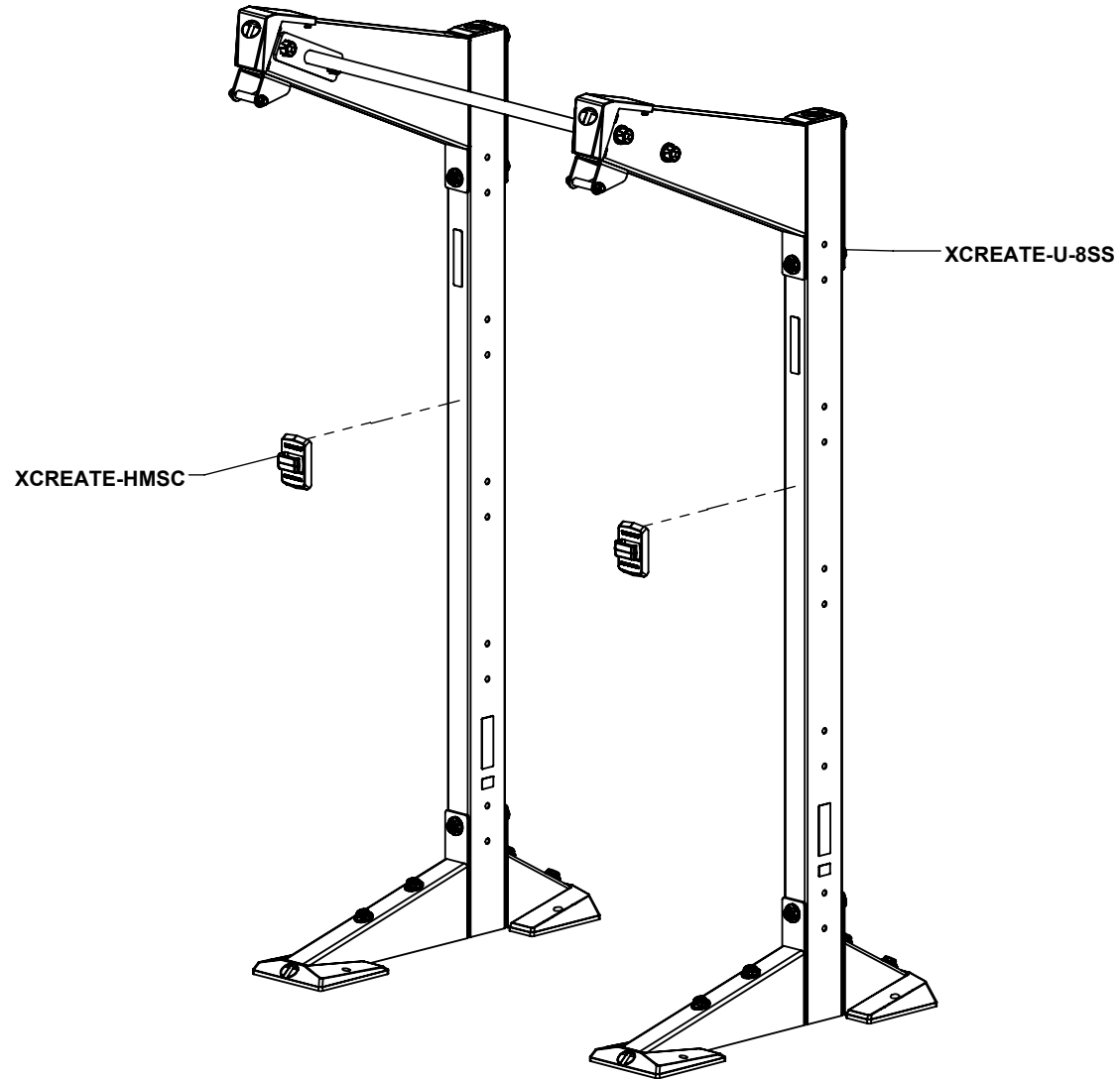

**NOTES:**

Suspension storage clip can be positioned to desired height.

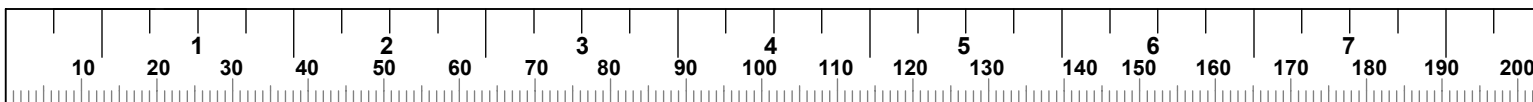

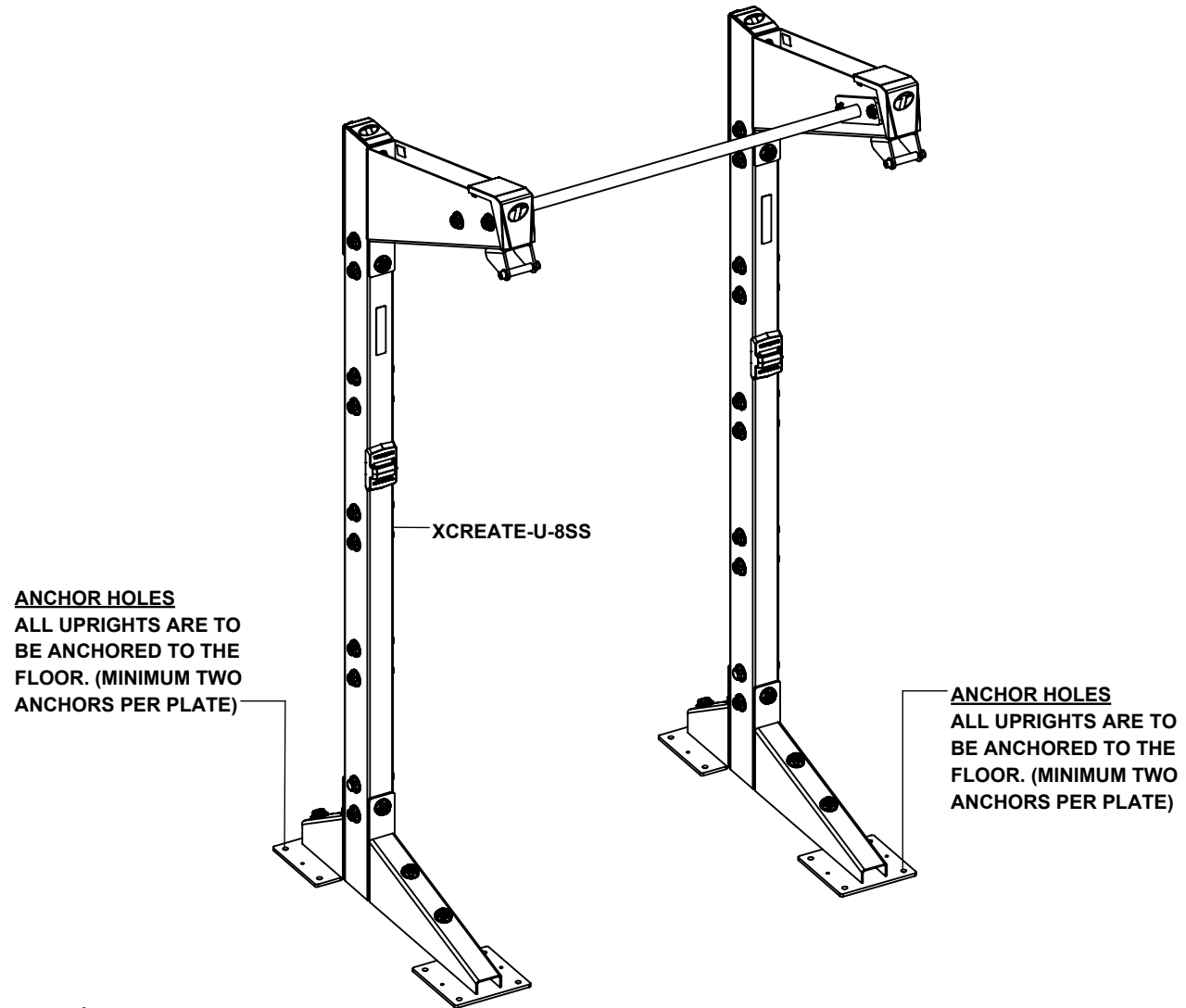

**NOTES:**

Make sure all bolts are **SECURELY** tightened.

Position system to desired location in the room.

Anchor system to the floor referencing X-CREATE ANCHORING INSTRUCTIONS which can be downloaded at [www.torquefitness.com/assembly-manuals](http://www.torquefitness.com/assembly-manuals)

**WARNING!**

**ALL X-CREATE ARE REQUIRED TO BE ANCHORED TO THE FLOOR TO PREVENT ROCKING OR TIPPING DURING USE.**

# XCREATE-URETHANE BOOTS

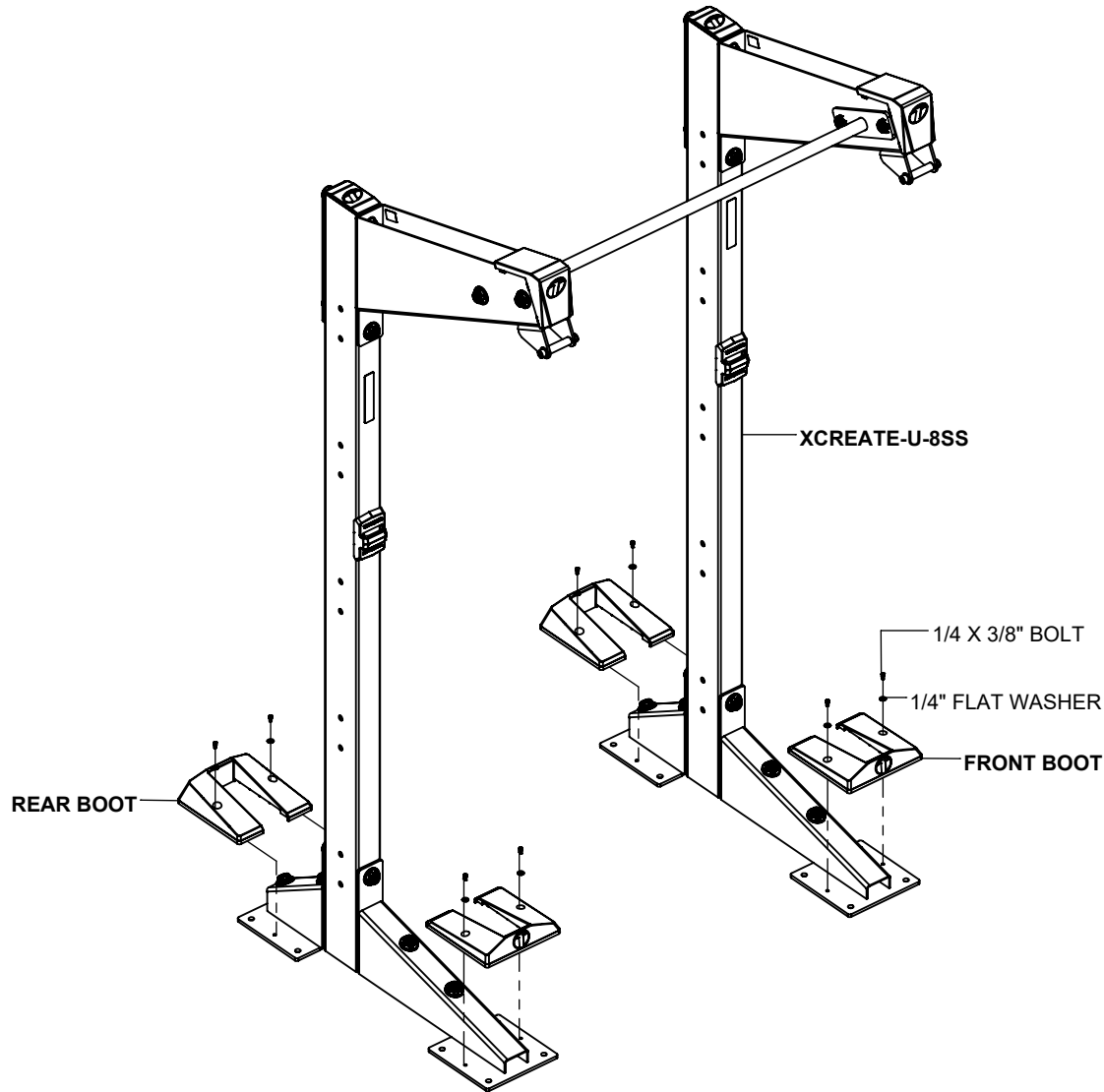

REAR BOOT

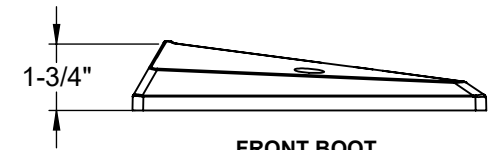

FRONT BOOT

## NOTES:

The URETHANE BOOTS and hardware are packaged with the upright boxes

**SECURELY** tighten bolt connections in this step.

The **XCREATE-U-7SS** is assembled the exact same way.

Repeat this step for every upright.

