

PRINSU ROOF RACK INSTALLATION GUIDE



SUBARU ASCENT

All products built and designed by Prinsu Design Studio are intended for off-road use and should be assembled, installed, and used according to Prinsu Design Studio's recommendations. Prinsu Design Studio products should be used safely with good judgment towards others and the environment. By installing Prinsu Design Studio Products on your vehicle you assume all liability. Prinsu Design Studio will not be held liable for damages or loss associated with the installation or use of its products. Be smart, use good judgement, don't overload your vehicle to the point of inferior handling and maneuverability!

PRINSU ROOF RACK INSTALLATION GUIDE

CROSSBAR HARDWARE DIAGRAM

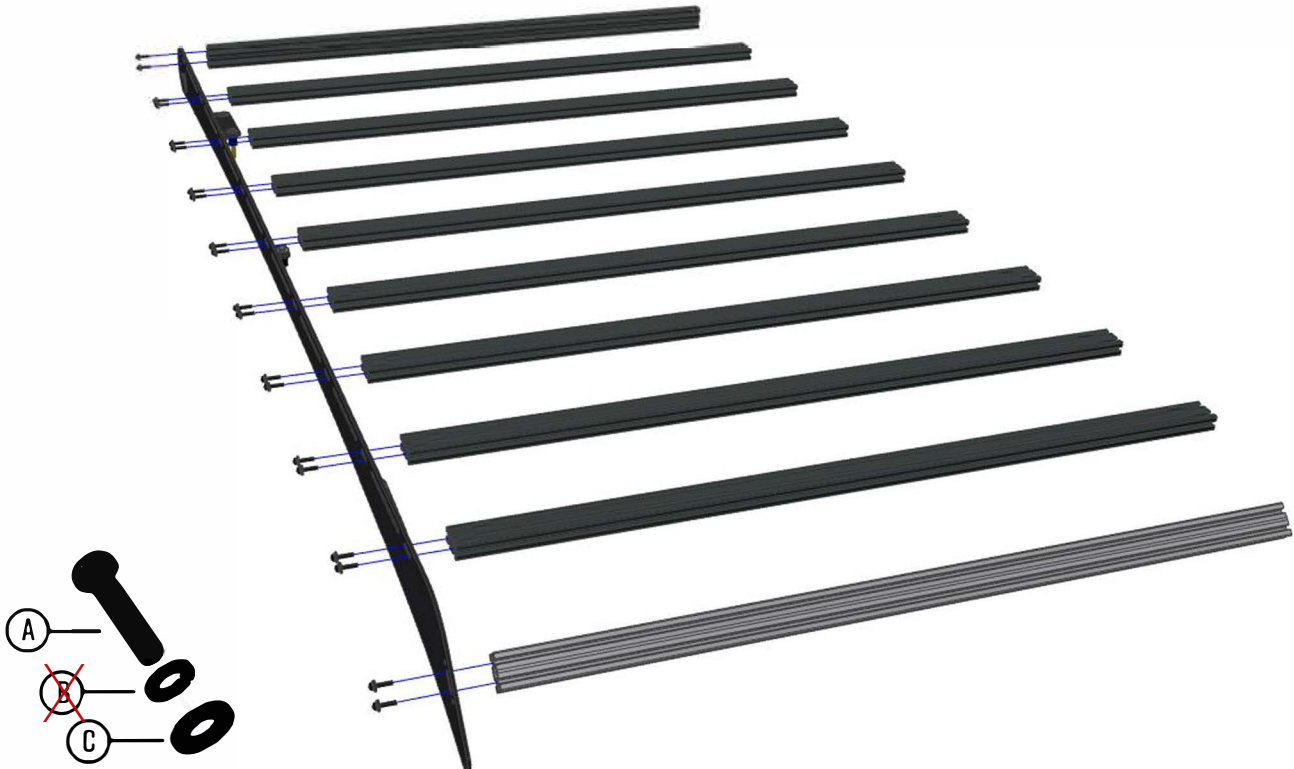

***NOTE:** The appropriate torque for a 1/4 - 20 grade two bolt is between 37 - 43 in-lbs. Which is approximately 3 ft- lbs. The heads will shear off between 15-20 ft-lbs. **Use caution when using power tools.**

A

***NOTE:** The 1/4 Lock washers are no longer included with the hardware. Use the provided tube of thread lock instead.

B

PART	DESCRIPTION	QUANTITY
A	1/4" - 20 x 1" MACHINE SCREW	40
B	1/4" LOCK WASHER	40
C	1/4" FLAT WASHER	40

All products built and designed by Prinsu Design Studio are intended for off-road use and should be assembled, installed, and used according to Prinsu Design Studio's recommendations. Prinsu Design Studio products should be used safely with good judgment towards others and the environment. By installing Prinsu Design Studio Products on your vehicle you assume all liability. Prinsu Design Studio will not be held liable for damages or loss associated with the installation or use of its products. Be smart, use good judgement, don't overload your vehicle to the point of inferior handling and maneuverability!

PRINSU ROOF RACK INSTALLATION GUIDE

WIND DEFLECTOR HARDWARE DIAGRAM

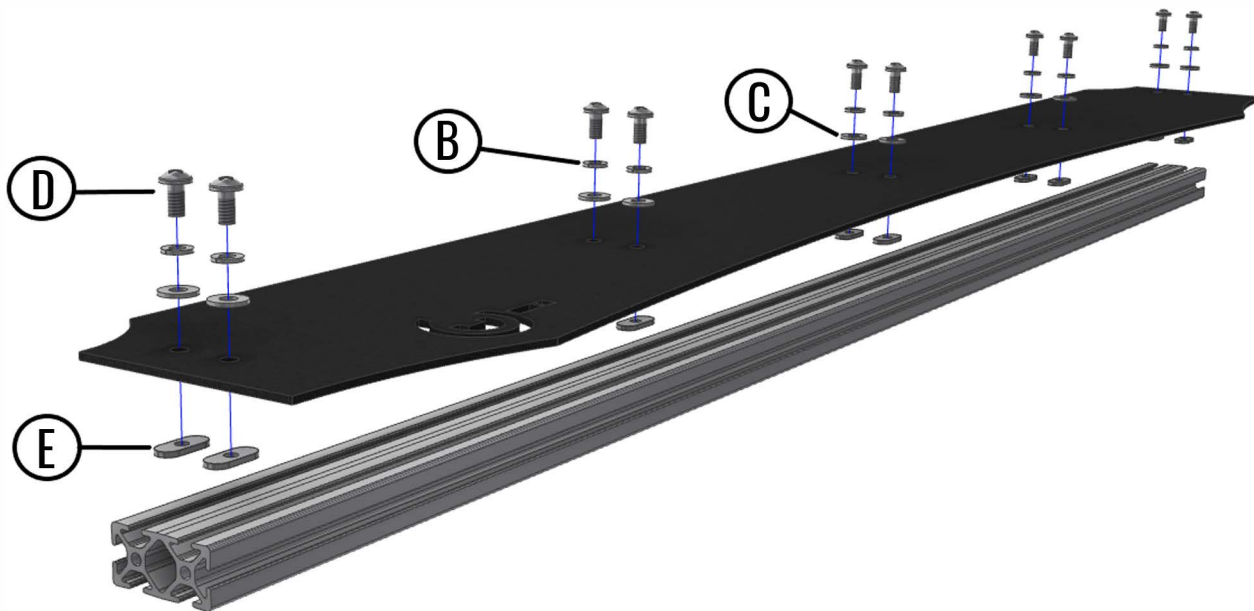

PART	DESCRIPTION	QUANTITY
B	1/4" LOCK WASHER	10
C	1/4" FLAT WASHER	10
D	1/4" - 20 x 1/2" PAN HEAD SCREW	10
E	1/4" - 20, 10 SERIES T-NUT	10

All products built and designed by Prinsu Design Studio are intended for off-road use and should be assembled, installed, and used according to Prinsu Design Studio's recommendations. Prinsu Design Studio products should be used safely with good judgment towards others and the environment. By installing Prinsu Design Studio Products on your vehicle you assume all liability. Prinsu Design Studio will not be held liable for damages or loss associated with the installation or use of its products. Be smart, use good judgement, don't overload your vehicle to the point of inferior handling and maneuverability!

PRINSU ROOF RACK INSTALLATION GUIDE

MOUNTING HARDWARE DIAGRAM

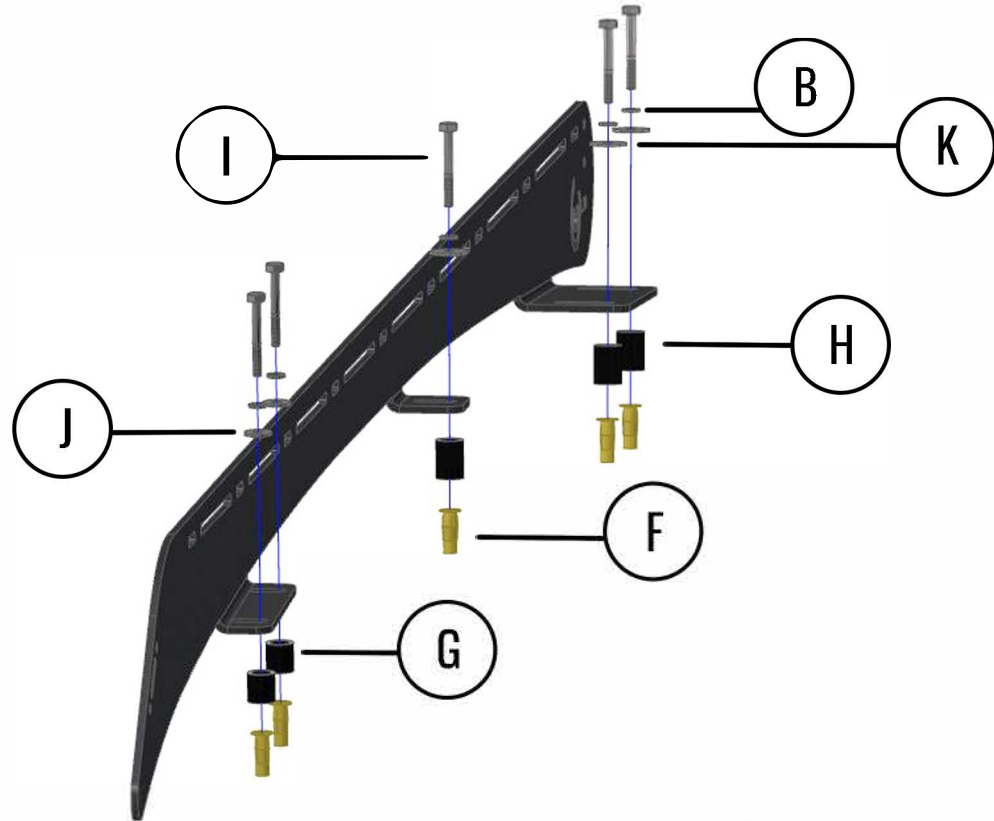

PART	DESCRIPTION	QUANTITY
F	1/4" - 20 PLUS NUT	10
G	3/4" x .509" x 3/4" LONG SPACER	4
H	3/4" x .509" x 1" LONG SPACER	6
I	1/4" - 20 x 2" HEX CAP SCREW	10
J	5/16" SAE FLAT WASHER	4
K	1/4" x 1" FENDER WASHER	6
B	1/4" LOCK WASHER	10

All products built and designed by Prinsu Design Studio are intended for off-road use and should be assembled, installed, and used according to Prinsu Design Studio's recommendations. Prinsu Design Studio products should be used safely with good judgment towards others and the environment. By installing Prinsu Design Studio Products on your vehicle you assume all liability. Prinsu Design Studio will not be held liable for damages or loss associated with the installation or use of its products. Be smart, use good judgement, don't overload your vehicle to the point of inferior handling and maneuverability!

PRINSU ROOF RACK INSTALLATION GUIDE

WIND DEFLECTOR ATTACHMENT

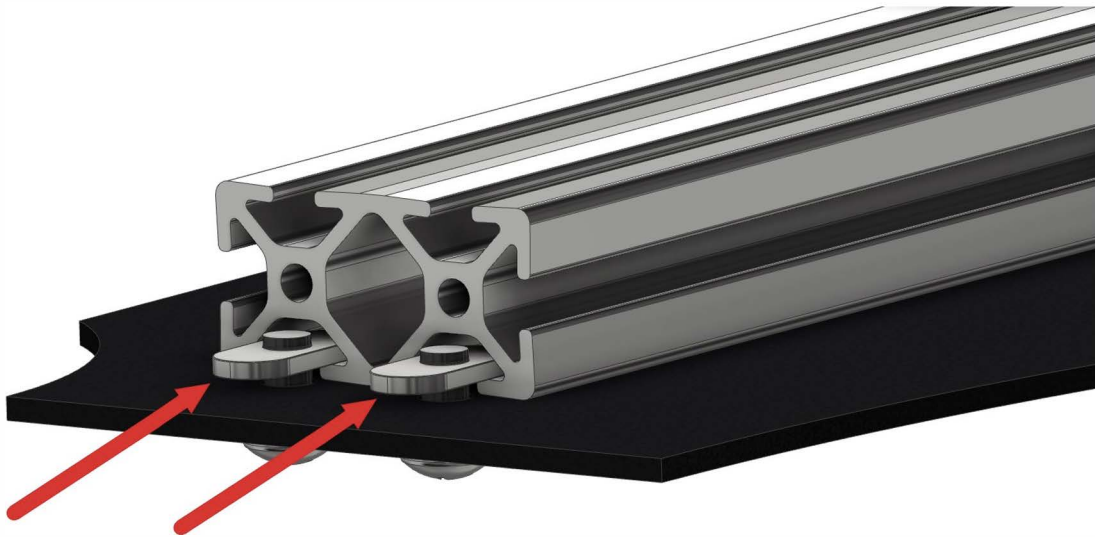

STEPS

1. Install the wind deflector hardware as shown in the diagram on page 3. Thread the screws just barely into the T-Nuts to begin with.
2. Lay the wind deflector on a flat surface in the orientation shown above.
3. From one end start sliding the extrusion bar so that the T-Nuts feed into the channel.
4. Once everything is lined up properly they will slide right together.
5. Now with all the T-Nuts fed into the channel and the extrusion bar and wind deflector lined up flush at both ends, turn the assembly over and tighten the screws until the lock washers are fully compressed.
6. The wind deflector assembly can now be bolted to the roof rack.

All products built and designed by Prinsu Design Studio are intended for off-road use and should be assembled, installed, and used according to Prinsu Design Studio's recommendations. Prinsu Design Studio products should be used safely with good judgment towards others and the environment. By installing Prinsu Design Studio Products on your vehicle you assume all liability. Prinsu Design Studio will not be held liable for damages or loss associated with the installation or use of its products. Be smart, use good judgement, don't overload your vehicle to the point of inferior handling and maneuverability!

PRINSU ROOF RACK INSTALLATION GUIDE

STOCK ROOF RAIL REMOVAL INSTRUCTIONS

***If you do not feel comfortable with the process outlined in this manual please seek professional installation assistance**

***Please read all instruction prior to beginning installation. Various steps may relate directly to previous or future parts of the installation process. Prinsu Design Studio is not liable for damages caused to your vehicle during the installation process**



Drop down sunglasses holder.



Remove two screws on the sunglasses holder. Pry down to remove assembly.



Pull handle down and locate release tabs.



Pull down on tab and out on clip.



Pull down visor and remove plastic cover.



Remove the screws and drop down the visor. Undo any electrical plugs if necessary.

All products built and designed by Prinsu Design Studio are intended for off-road use and should be assembled, installed, and used according to Prinsu Design Studio's recommendations. Prinsu Design Studio products should be used safely with good judgment towards others and the environment. By installing Prinsu Design Studio Products on your vehicle you assume all liability. Prinsu Design Studio will not be held liable for damages or loss associated with the installation or use of its products. Be smart, use good judgement, don't overload your vehicle to the point of inferior handling and maneuverability!

PRINSU ROOF RACK INSTALLATION GUIDE



Remove visor clip with small flat head into the opening and pull down clip.



Pull out A-pillar panel.



Remove upper & lower clips from A-pillar.



Pull out on the lower B-pillar panel.



With the lower B-pillar panel pulled back remove the bolt from the upper B-pillar panel.



Pull upper B-pillar panel down.



Pull out on C-pillar trim.



Remove upper trim from the cargo area.

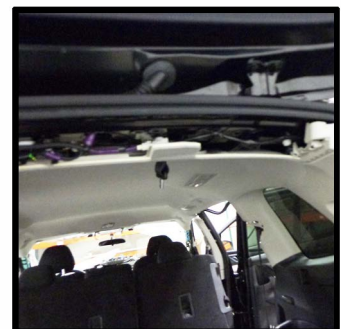

With trim removed.

All products built and designed by Prinsu Design Studio are intended for off-road use and should be assembled, installed, and used according to Prinsu Design Studio's recommendations. Prinsu Design Studio products should be used safely with good judgment towards others and the environment. By installing Prinsu Design Studio Products on your vehicle you assume all liability. Prinsu Design Studio will not be held liable for damages or loss associated with the installation or use of its products. Be smart, use good judgement, don't overload your vehicle to the point of inferior handling and maneuverability!

PRINSU ROOF RACK INSTALLATION GUIDE



Remove cover to expose screw.



Remove screw.



Remove cover to expose screw.



Remove screw.



Pull out on lower D-pillar panels. This exposes a clip that will allow the C-pillar panel to be fully removed.

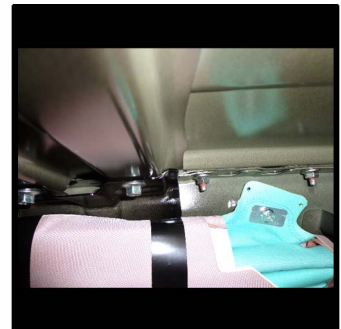

Remove roof climate control vent system if equipped.



The bolts holding the roof rails in are now exposed and the nuts can now be removed.



Now with the stock rails removed drill out the holes to 3/8". * Using a drill stop is recommended.



View of bottom hole drilled, be sure to clean any shavings away that fell thru while drilling.

All products built and designed by Prinsu Design Studio are intended for off-road use and should be assembled, installed, and used according to Prinsu Design Studio's recommendations. Prinsu Design Studio products should be used safely with good judgment towards others and the environment. By installing Prinsu Design Studio Products on your vehicle you assume all liability. Prinsu Design Studio will not be held liable for damages or loss associated with the installation or use of its products. Be smart, use good judgement, don't overload your vehicle to the point of inferior handling and maneuverability!

PRINSU ROOF RACK INSTALLATION GUIDE

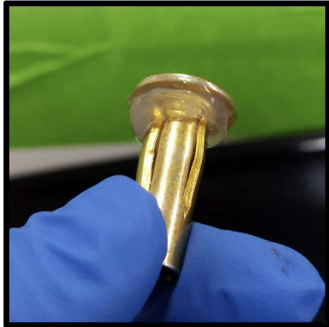

Next apply silicone to the plusnuts before inserting to insure a water tight seal.



Insert into the roof.



Compress the plusnut by using a 1/2" wrench to hold the coupler & tighten with an 11mm wrench.



Apply more silicone to insure a water tight seal and place the spacer on the roof.



Once all plus nuts are fully installed & your headliner is reinstalled you can now install the roof rack.



Before your 1st drive double check all fasteners to insure they are fully secured.



From there on out periodically check all fasteners to insure they remain fully secured.

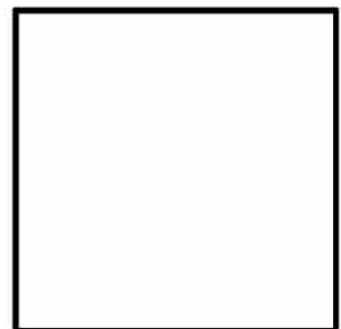
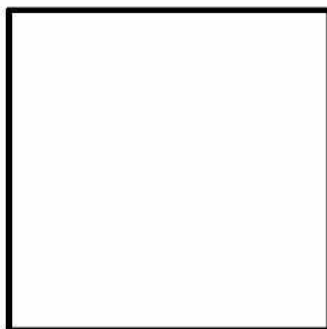

All products built and designed by Prinsu Design Studio are intended for off-road use and should be assembled, installed, and used according to Prinsu Design Studio's recommendations. Prinsu Design Studio products should be used safely with good judgment towards others and the environment. By installing Prinsu Design Studio Products on your vehicle you assume all liability. Prinsu Design Studio will not be held liable for damages or loss associated with the installation or use of its products. Be smart, use good judgement, don't overload your vehicle to the point of inferior handling and maneuverability!

PRINSU ROOF RACK INSTALLATION GUIDE

WARRANTY

PRINSU DESIGN STUDIO will warranty all PRINSU DESIGN STUDIO manufactured parts for a LIFETIME of use. This limited Lifetime Warranty is effective for as long as the original retail purchaser owns the product. This warranty terminates when the original retail purchaser sells or otherwise transfers the product to any other person. Each manufactured product must be installed following PRINSU DESIGN STUDIO'S recommended fitment and installation procedures. Any customization or modification to the original product design, functionality, or use, either by said customer or by PRINSU DESIGN STUDIO voids all warranty eligibility. It is the sole discretion of CBI Offroad to determine warranty eligibility. Subject to the limitations and exclusions described in this warranty, PRINSU DESIGN STUDIO will remedy defects in materials or workmanship by repairing or replacing, at its option, a defective product without charge for parts. In addition, PRINSU DESIGN STUDIO may elect, at its option, not to repair or replace a defective product but rather issue to a purchaser a refund equal to the purchase price paid for the product or a credit to be used toward the purchase of a new PRINSU DESIGN STUDIO product. No warranty is given for defects caused by normal wear and tear, cosmetic rust scratches, accidents, unlawful vehicle operation, products used for racing or competition, or modification of, or any types of repair of, a PRINSU DESIGN STUDIO manufactured product. The PRINSU DESIGN STUDIO Warranty does not include the powder coated finish. No warranty is given for defects resulting from conditions beyond PRINSU DESIGN STUDIO'S control including, but not limited to, misuse, neglect, overloading, improperly maintained or failure to assemble, mount or use the product in accordance with PRINSU DESIGN STUDIO'S written instructions or guidelines included with the product or implied use made available to the purchaser.

DISCLAIMER OF LIABILITY REPAIR OR REPLACEMENT OF A DEFECTIVE PRODUCT OR THE ISSUANCE OF A REFUND OR CREDIT (AS DETERMINED BY PRINSU DESIGN STUDIO) IS A PURCHASER'S EXCLUSIVE REMEDY UNDER THIS WARRANTY. DAMAGE TO A PURCHASER'S VEHICLE, CARGO AND/OR TO ANY OTHER PERSON OR PROPERTY IS EXCLUDED. THIS WARRANTY IS EXPRESSLY MADE IN LIEU OF ANY AND ALL OTHER WARRANTIES, EXPRESS OR IMPLIED, INCLUDING THE WARRANTIES OF MERCHANTABILITY AND FITNESS FOR A PARTICULAR PURPOSE. PRINSU DESIGN STUDIO'S SOLE LIABILITY TO ANY PURCHASER IS LIMITED TO THE REMEDY SET FORTH ABOVE. IN NO EVENT WILL PRINSU DESIGN STUDIO BE LIABLE FOR ANY LOST PROFITS, LOST SALES, OR FOR ANY CONSEQUENTIAL, DIRECT, INDIRECT, INCIDENTAL, SPECIAL, EXEMPLARY, OR PUNITIVE DAMAGES OR FOR ANY OTHER DAMAGES OF ANY KIND OR NATURE

PRINSU ROOF RACK SPECIFICATION GUIDE

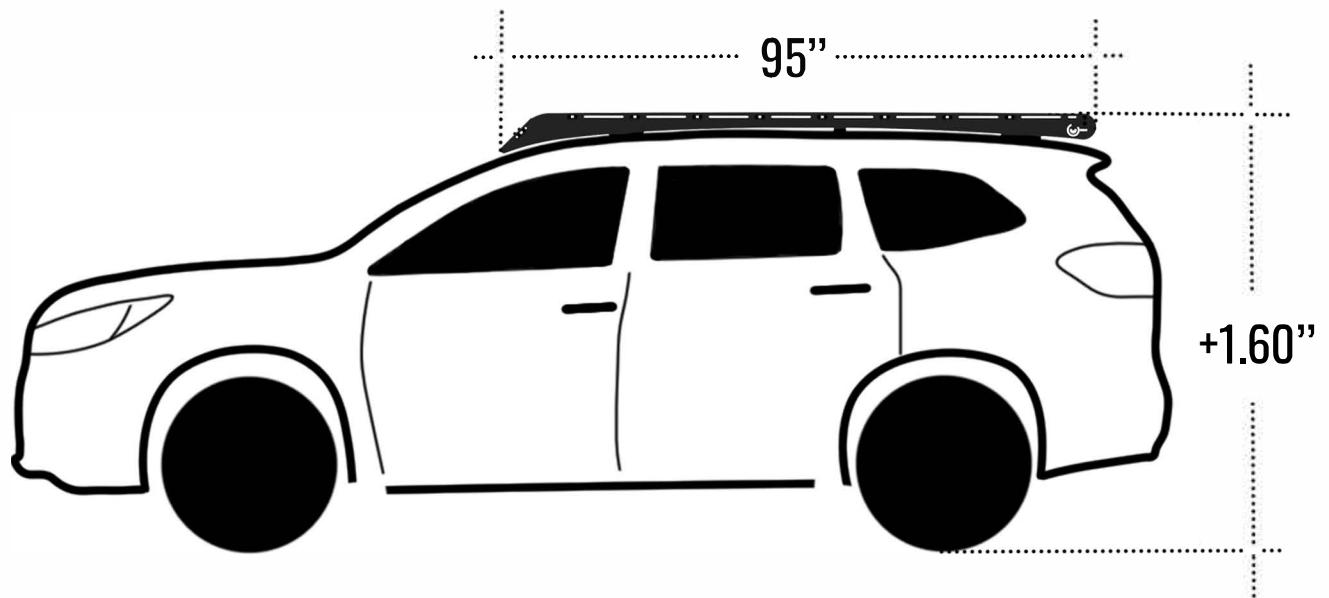

FEATURE	MEASUREMENT/QUANTITY
OVERALL LENGTH	95"
SIDE RAIL HEIGHT*	2.60"
HEIGHT ADDED **	1.60"
CLEARANCE BETWEEN ROOF AND RACK	7/16"
WEIGHT	~ 56 LBS
48.5" CROSS BARS - BLACK - (1X2)	9
48.5" CROSS BAR - CLEAR - (1X2)	1

*AS MEASURED AT THE CENTER OF THE SIDE RAIL

**AS MEASURE FROM THE CENTER POINT OF THE ROOF

All products built and designed by Prinsu Design Studio are intended for off-road use and should be assembled, installed, and used according to Prinsu Design Studio's recommendations. Prinsu Design Studio products should be used safely with good judgment towards others and the environment. By installing Prinsu Design Studio Products on your vehicle you assume all liability. Prinsu Design Studio will not be held liable for damages or loss associated with the installation or use of its products. Be smart, use good judgement, don't overload your vehicle to the point of inferior handling and maneuverability!