

Internal gear pump
Fixed displacement

Type PGH

RE 10223

Edition: 2019-02

Replaces: 04.2013



- ▶ Frame size 2 and 3
- ▶ Size 5 ... 16
- ▶ Component series 2X
- ▶ Maximum operating pressure 350 bar
- ▶ Displacement 5.2 ... 16.0 cm³

Features

- ▶ Fixed displacement
- ▶ Low operating noise
- ▶ Low flow pulsation
- ▶ High efficiency also at low speed and viscosity due to sealing gap compensation
- ▶ Suitable for broad viscosity and speed ranges
- ▶ Can be combined with internal gear pumps, radial piston pumps, gerotor pumps and external gear pumps
- ▶ Mounting dimensions according to ISO 3019-1.
- ▶ Connection dimensions according to ISO 6162-1
- ▶ Suitable for HLP, HETG, HEES and HFD and HFC hydraulic fluids
- ▶ Use in fatigue endurable drives with high pressures at very high numbers of load cycles with constant or variable speed in direct drives or with accumulator charging function, e.g.:
 - Plastics processing machines
 - Machine tools
 - Presses
 - Test stands

Inhalt

Ordering code	2
Functional description	3
Technical data	4
Average characteristic curve values of frame sizes 2 and 3	5
Dimensions of frame size 2	6
Dimensions of frame size 3	7
Multiple pumps	9
Project planning information	12
Installation information	13
Commissioning information	14

Ordering code

01	02	03	04	05	06	07	08	09	10	11
PG	H		-	2X	/		07		U2	

Type

01	Internal gear pump, fixed displacement, gap-compensated	PG
----	---	-----------

Series

02	High-pressure pump, peak pressure 350 bar	H
----	---	----------

Frame sizes BG

03	BG2	2
	BG3	3

Component series

04	Component series 20 ... 29 (20 ... 29: unchanged installation and connection dimensions)	2X
----	--	-----------

Sizes

		NG	
05	BG2	5	005
		6	006
		8	008
BG3	11	011	
	13	013	
	16	016	

Directions of rotation

06	Viewed on drive shaft	clockwise	R
		counterclockwise	L

Drive shafts

07	Cylindrical shaft with fitting key, DIN 6885		E
	Splined shaft according to ISO 3019-1	16-4 9T 16/32DP	R
		19-4 11T 16/32DP	S

Line connections

08	Suction and pressure port: SAE flange connection according to ISO 6162-1	07
----	--	-----------

Seals

09	FKM seals and FKM shaft seal ring, suitable for HLP, HETG, HEES and HFD hydraulic fluids	V
	FKM seals with NBR shaft seal rings, suitable for HFC hydraulic fluids	W

Mounting flange

10	2-hole mounting flange according to ISO 3019-1	U2
----	--	-----------

11	Further details in the plain text	
----	-----------------------------------	--

Order example

PGH3-2X/016RE07VU2

Material number

R900951305

Not all variants according to the type key are possible!

Please select the desired pump using the selection

tables (page 6 to 8) or after consultation with

Bosch Rexroth.

Functional description

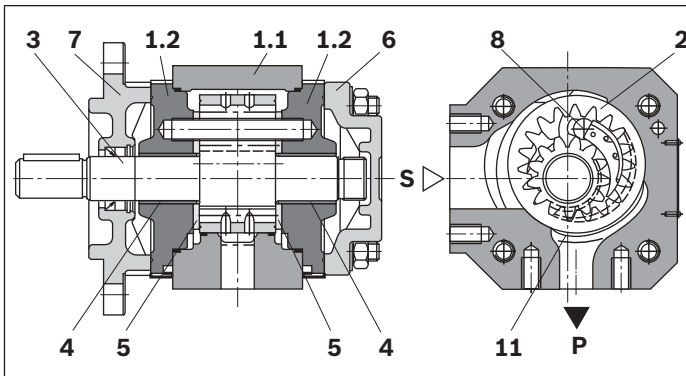

Set-up

Hydraulic pumps of type PGH are gap-compensated internal gear pumps with constant displacement.

They basically comprise of housing (1.1), bearing cover (1.2), internal gear (2), pinion shaft (3), plain bearings (4), axial washers (5), end cover (6), mounting flange (7) and stop pin (8), as well as the segment filler element (9) consisting of segment (9.1), segment support (9.2) and the sheet seals (9.3).

Suction and displacement procedure

The hydrodynamically supported pinion shaft (3) drives the internally geared internal gear (2) in the displayed direction of rotation.

During the rotation, there is a volume increase over an angle of approx. 90° in the suction range. An underpressure results and fluid flows into the chambers.

The sickle-shaped segment filler element (9) separates suction and pressure chamber. In the pressure chamber, the teeth of the pinion shaft (3) engage in the space between the teeth of the internal gear (2) again. The liquid is displaced via the pressure channel (P).

Axial compensation

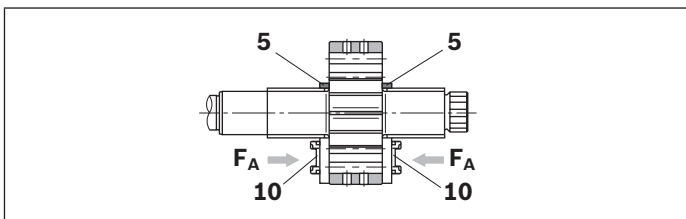

The axial compensation force F_A takes effect in the area of the pressure chamber and is generated with the pressure field (10) in the axial washers (5).

So the axial longitudinal gaps between the rotating and the fixed parts are extraordinarily small and ensure perfect axial sealing of the pressure chamber.

Radial compensation

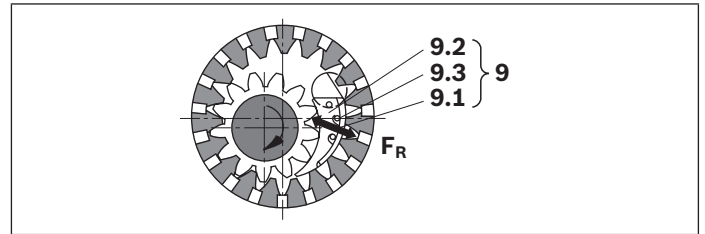

The radial compensation force F_R acts on segment (9.1) and segment support (9.2).

Dependent on the operating pressure, the two segment filler elements (9.1) and (9.2) are pressed against the head diameters of pinion shaft (3) and internal gear (2).

The area ratios and the position of the sheet seal (9.3) between the segment and segment support are designed so that an almost leakage gap-free sealing between internal gear (2), segment filler element (9) and pinion shaft (3) is achieved.

Spring elements under the sheet seals (9.3) ensure sufficient contact pressure, also with very low pressures.

Hydrodynamic and hydrostatic mounting

The forces acting on the pinion shaft (3) are accepted by hydrodynamically lubricated radial plain bearings (4); the forces acting on the internal gear (2) by the hydrostatic bearing (11).

Gear tooth system

The gear tooth system is an involute tooth system. Its large meshing length results in little flow and pressure pulsation; these little pulsation rates considerably contribute to the low-noise running.

▼ Symbol

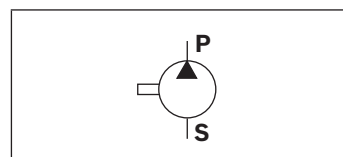

Technical data

Frame size		BG	2	2	2	3	3	3
Size		NG	5	6	8	11	13	16
Displacement, geometrical	V_g	cm ³	5.24	6.5	8.2	11.0	13.3	16.0
Drive speed	n_{min}	rpm				600		
	n_{max}	rpm				3000		
Minimum drive power required	p_{suppl}	kW				0.55		
Operating pressure, absolute								
Input	p	bar	0.8 ... 2 (shortly, upon start 0.6 bar)					
Output permanent	Mineral oils	p_n	bar			315		
	Special fluids	p_n	bar			210		
intermittent ¹⁾	Mineral oils	p_{max}	bar			350		
	Special fluids	p_{max}	bar			230		
Flow (at $n = 1450$ rpm; $p = 10$ bar; $v = 46$ mm ² /s)	q_v	l/min	7.5	9.3	11.8	15.8	19.1	23.0
Weight	m	kg	4.3	4.4	4.6	4.8	5	5.3
Shaft load	Radial and axial forces (e.g. belt pulley) only after coordination							
Type of mounting	Flange mounting							
Hydraulic fluid		Classification			Suitable seal design		Standards	Data sheet
Mineral oils		HLP, HLPD, HVLP, HVLPD			V		DIN 51524	90220
Special fluids	▶ environmentally compatible	HETG			V		ISO 15380	90221
		HEES						
		HEPG						
Special fluids	▶ water-free, flame-resistant	HFDU			V		ISO 12922	90222
		HFDR						
Special fluids	▶ containing water, flame-resistant	HFC			W		ISO 12922	90223
Further information on the hydraulic fluids:								
Temperature range	°C	▶ Mineral oils			-10 ... +80; for other temperatures please consult us!			
	°C	▶ Special fluids			-10 ... +50; for other temperatures please consult us!			
Ambient temperature range	°C	-20 ... +60						
Viscosity range	mm ² /s	10 ... 300; admissible start viscosity 2000						
Maximum admissible degree of contamination of the hydraulic fluid	Class 20/18/15							
Cleanliness class according to ISO 4406 (c)								

Notice

For applications outside these parameters, please consult us!

1) Maximum 10s, at most 50% of the duty cycle

Average characteristic curve values of frame sizes 2 and 3

▼ Flow

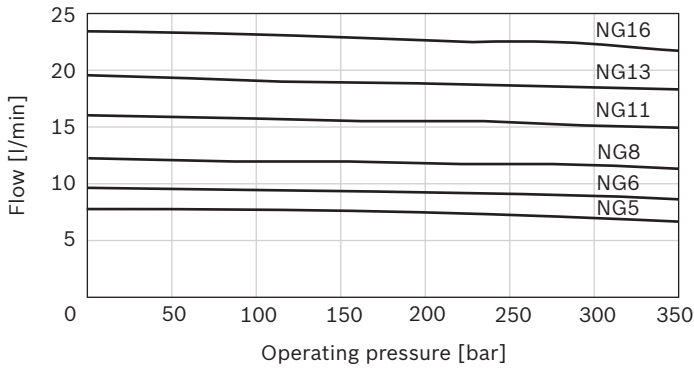

▼ Efficiency

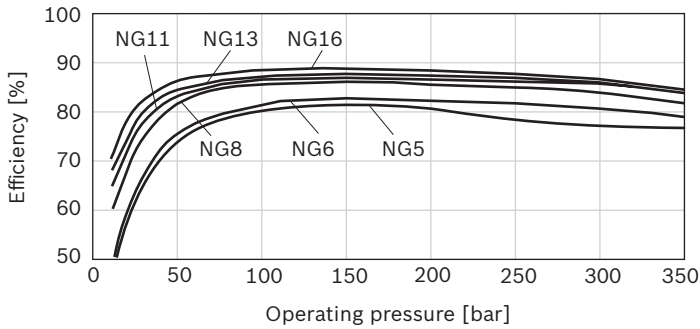

▼ Drive power

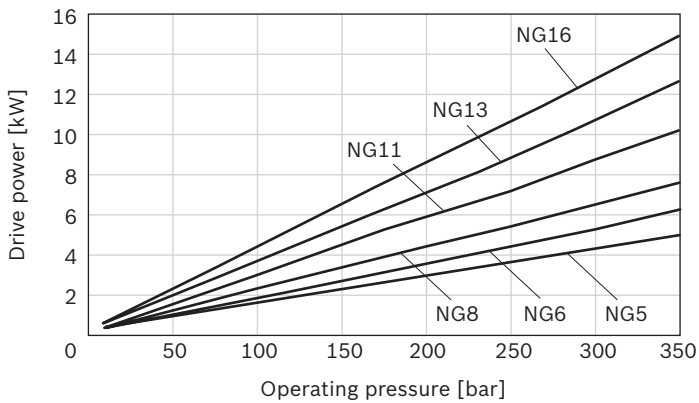

▼ Sound pressure level

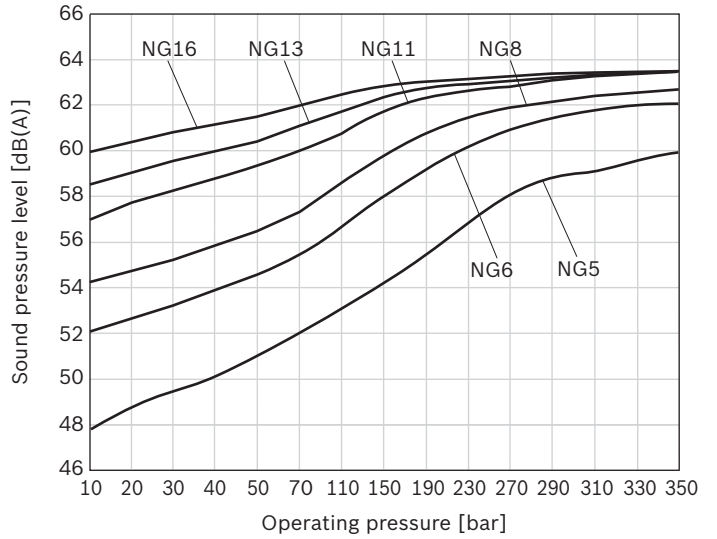

Notice

- ▶ Characteristic curves measured at $n = 1450 \text{ rpm}$; $v = 41 \text{ mm}^2/\text{s}$; $\theta = 50 \text{ }^\circ\text{C}$
- ▶ Sound pressure level measured in the sound measuring chamber according to DIN 45635, sheet 26; distance: Microphone – pump = 1 m

Dimensions of frame size 2

With cylindrical shaft or splined shaft and 2-hole mounting flange 82-2 according to ISO 3019-1

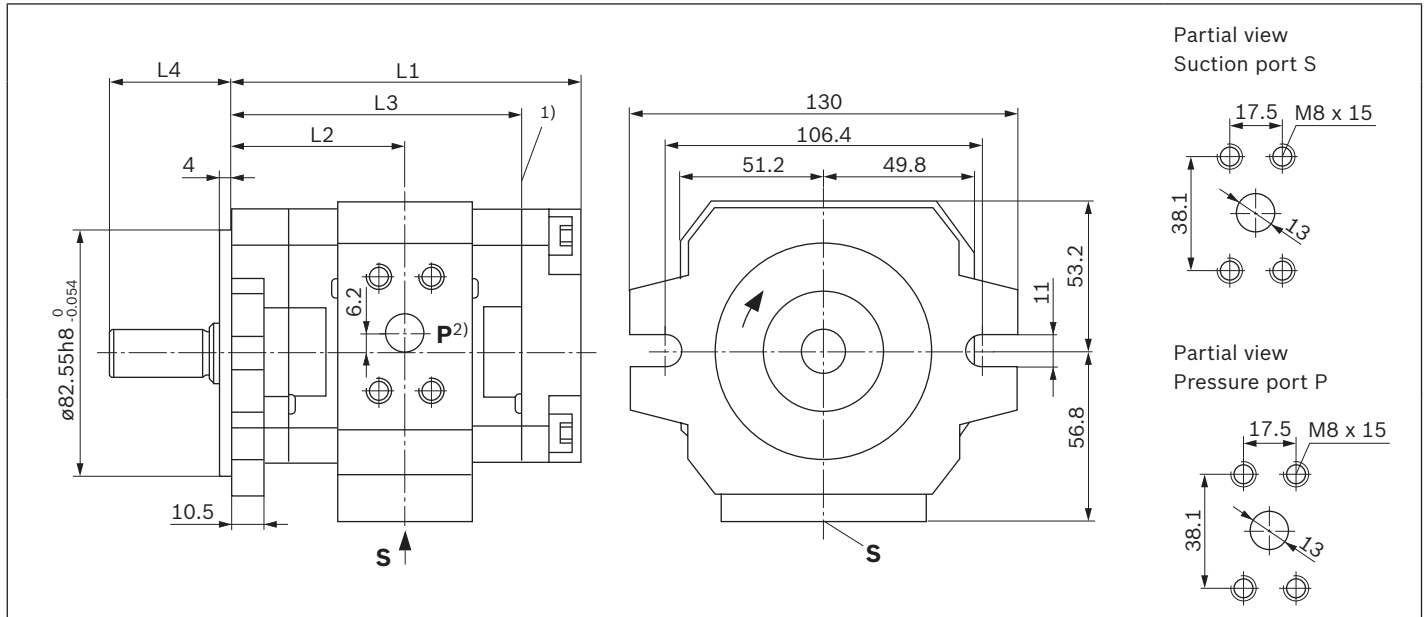

Type		Material numbers	L1	L2	L3	L4	Suction port S ³⁾	Pressure connection P ³⁾
PGH2-2X/005	R	R900968999	110	54.2	89.5			
	L	R900703725						
PGH2-2X/006	R	R900951301	112.5	55.5	92	41	DN13 (SAE 1/2")	DN13 (SAE 1/2")
	L	R900961547						
PGH2-2X/008	R	R900951302	116	57.3	95.5			
	L	R900961548						
PGH2-2X/005	R	R900972378	110	54.2	89.5			
	L	R900703727						
PGH2-2X/006	R	R900961549	112.5	55.5	92	31.5	DN13 (SAE 1/2")	DN13 (SAE 1/2")
	L	R900961550						
PGH2-2X/008	R	R900961551	116	57.3	95.5			
	L	R900961552						

▼ Cylindrical shaft with fitting key DIN 6885

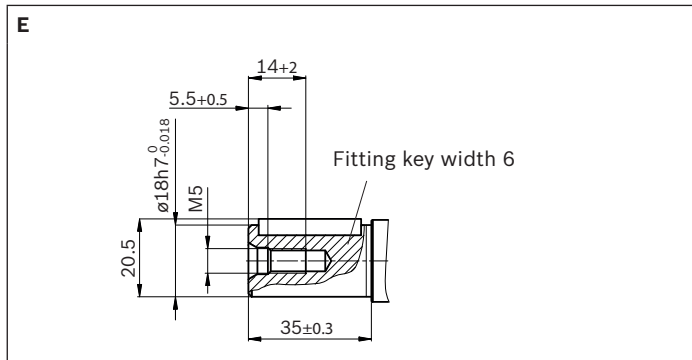

▼ Splined shaft according to ISO 3019-1

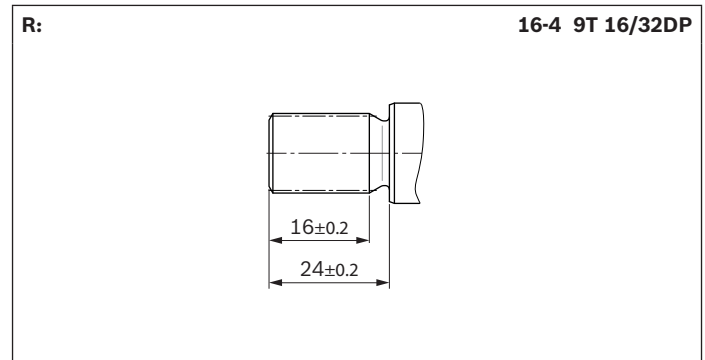

1) With multiple pumps, the combination part will start from here
2) The figure shows pumps with clockwise rotation; with pumps with counterclockwise rotation, the pressure port is on the opposite side!

3) SAE flange connection according to ISO 6162-1

Dimensions of frame size 3

With cylindrical shaft and 2-hole mounting flange 101-2 according to ISO 3019-1

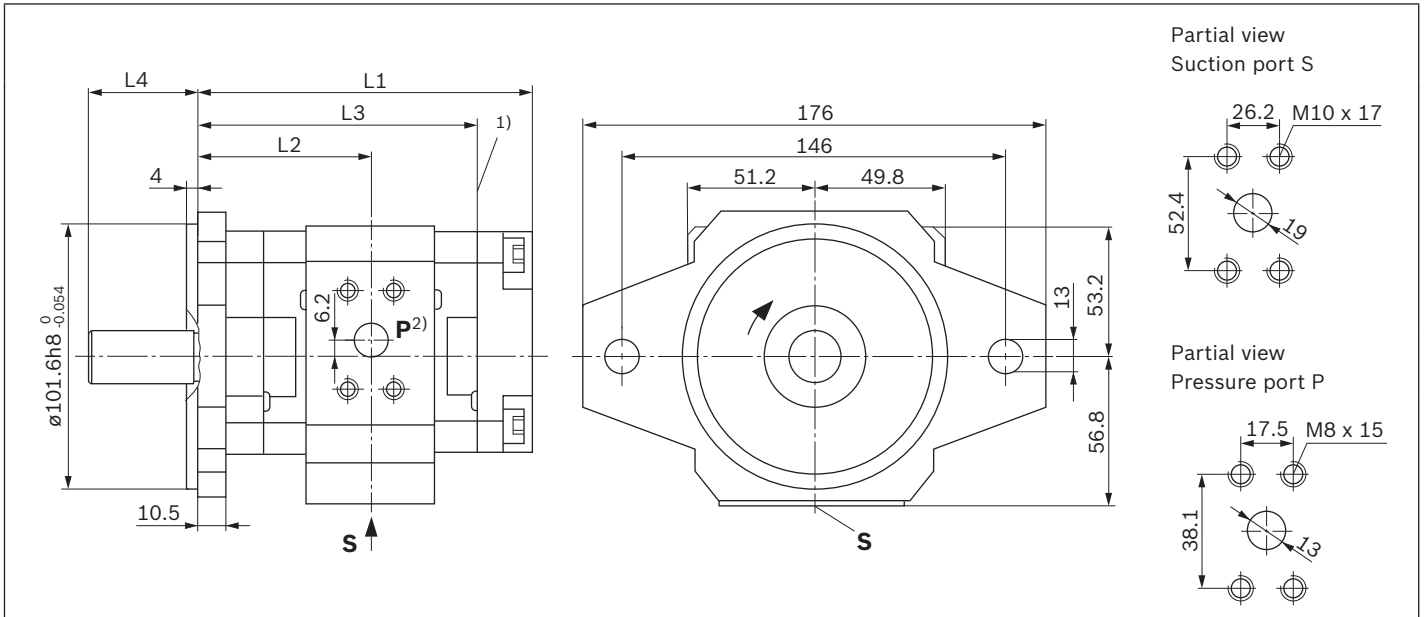

Type		Material numbers	L1	L2	L3	L4	Suction port S ³⁾	Pressure connection P ³⁾
PGH3-2X/	011	R E 07VU2	R900951303	128	66.5	107.5	DN25 (SAE 1")	DN13 (SAE 1/2")
		L	R900961553					
	013	R E 07VU2	R900951304	133	69	112.5		
		L	R900961554					
	016	R E 07VU2	R900951305	138	71.5	117.5		
		L	R900961555					

▼ Cylindrical shaft with fitting key DIN 6885

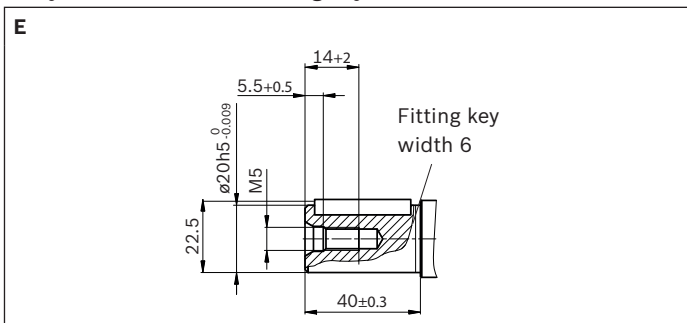

- 1) With multiple pumps, the combination part will start from here
- 2) The figure shows pumps with clockwise rotation; with pumps with counterclockwise rotation, the pressure port is on the opposite side!
- 3) SAE flange connection according to ISO 6162-1

With splined shaft and 2-hole mounting flange 82-2 according to ISO 3019-1

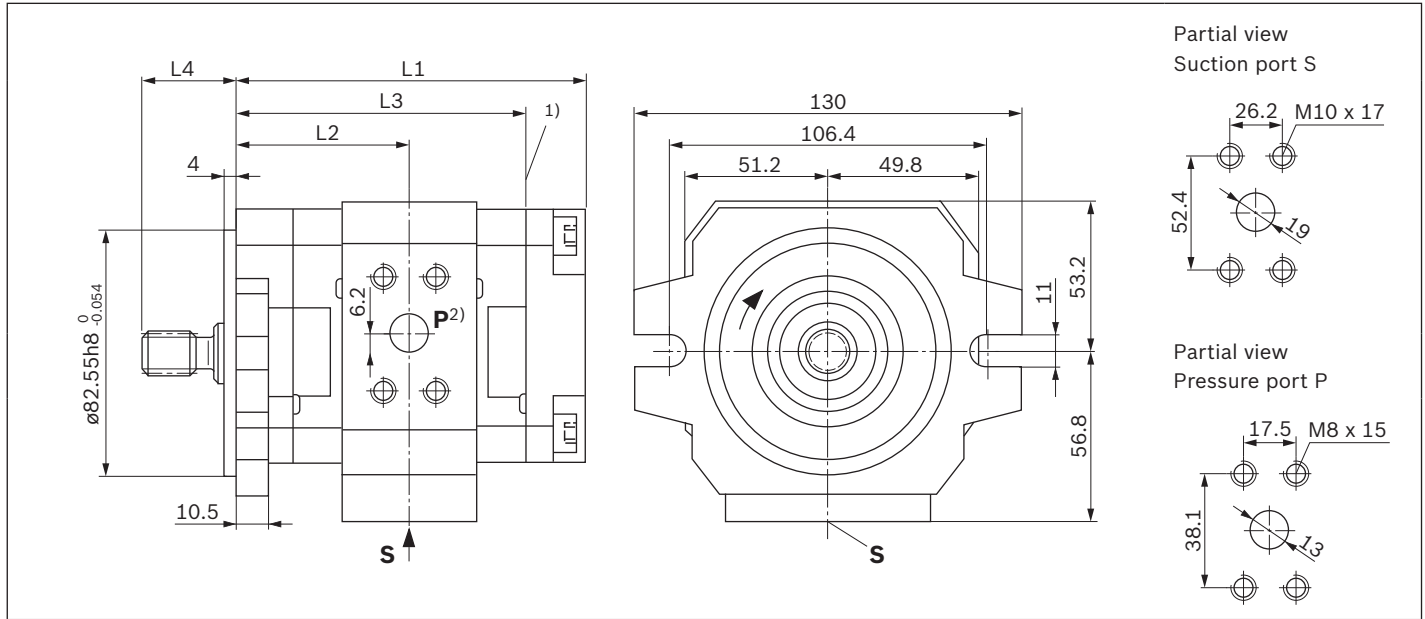

Type		Material numbers	L1	L2	L3	L4	Suction port S ³⁾	Pressure connection P ³⁾	
PGH3-2X/	011	R R 07VU2	R900961556	121.5	60	101	DN25 (SAE 1")	DN13 (SAE 1/2")	
		L R 07VU2	R900961559						
	013	R R 07VU2	R900961557	126.5	62.5	106			
		L R 07VU2	R900961560						
PGH3-2X/	016	R R 07VU2	R900961558	131.5	65	111	DN25 (SAE 1")	DN13 (SAE 1/2")	
		L R 07VU2	R900961561						
	016	R S 07VU2	R901281698	131.5	65	111			37
		L S 07VU2	R901465533						

▼ **Splined shaft according to ISO 3019-1**

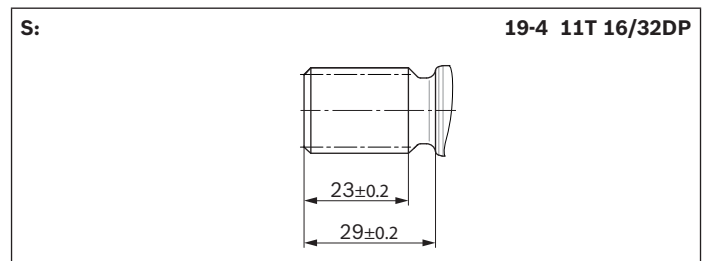
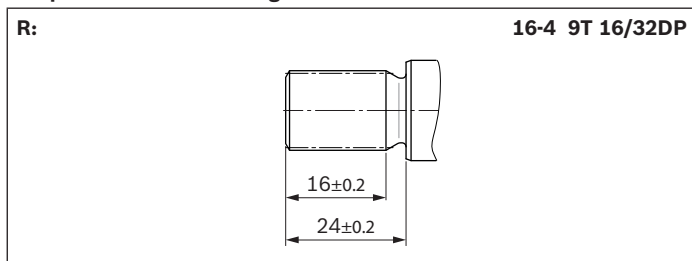

- 1) With multiple pumps, the combination part will start from here
- 2) The figure shows pumps with clockwise rotation; with pumps with counterclockwise rotation, the pressure port is on the opposite side!
- 3) SAE flange connection according to ISO 6162-1

Multiple pumps

All internal gear pumps of type PGH can be combined, every pump is equipped with an output gear tooth system. The possible combinations and the material numbers of the required combination parts are available in the following table.

Downstream pump	Upstream pump	
	PGH2-2X	PGH3-2X
PGH2-2X/...R...U2	R900886137	R900886137
PGH3-2X/...R...U2	R900886137	R900886137
PGP2-2X/...J...U2	R900886137	R900886137
PGF2-2X/...J...U2	R900886137	R900886137
AZPF...RR...B	R900886137	R900886137
PR4-1X...WA	R901015657	R901015657
PGZ4-1X/...T...U2	R901405441	R901405441
PGZ5-1X/...T...U2	R901405441	R901405441

10 **PGH** | Internal gear pump
Multiple pumps

Ordering code

01	02	03	04	05	06	07	08	09	10	11	12	13	14	15
		/	+	/	+	/				+		+		

Type ¹⁾

01	2-fold	P2
	3-fold	P3

02	Series of the first pump ¹⁾	
----	--	--

03	Size of the first pump ¹⁾	
----	--------------------------------------	--

04	Series of the second pump ¹⁾	
----	---	--

05	Size of the second pump ¹⁾	
----	---------------------------------------	--

06	Series of the third pump ¹⁾	
----	--	--

07	Size of the third pump ¹⁾	
----	--------------------------------------	--

Direction of rotation

08	Viewed on drive shaft	clockwise	R
		counterclockwise	L

Drive shaft of the first pump

09	Cylindrical shaft with fitting key, DIN 6885		E
	Splined shaft according to ISO 3019-1	16-4 9T 16/32DP	R
		19-4 11T 16/32DP	S

Line connection of the first pump

10	Suction and pressure port: SAE flange connection according to ISO 6162-1	07
----	--	-----------

Drive shaft of the second pump¹⁾

11	Cylindrical shaft with fitting key, DIN 6885		A
	Splined shaft according to ISO 3019-1	16-4 9T 16/32DP	J
		16-4 9T 16/32DP	R
		19-4 11T 16/32DP	T

Line connection of the second pump¹⁾

12	Suction and pressure port	
----	---------------------------	--

Drive shaft of the third pump¹⁾

13	Cylindrical shaft with fitting key, DIN 6885		A
	Splined shaft according to ISO 3019-1	16-4 9T 16/32DP	J
		16-4 9T 16/32DP	R
		19-4 11T 16/32DP	T

Line connection of the third pump¹⁾

14	Suction and pressure port	
----	---------------------------	--

Mounting flange of the first Pump

15	2-hole mounting flange according to ISO 3019-1	U2
----	--	-----------

¹⁾ For detailed information, see type key / data sheet of relevant pump

Dimensions

The dimensional drawings show the front pump and the combination part.¹⁾

PGH2/PGH3

PGH2/PGH3 with combination part for PGH2, PGH3, PGF2, PGP2, AZPF

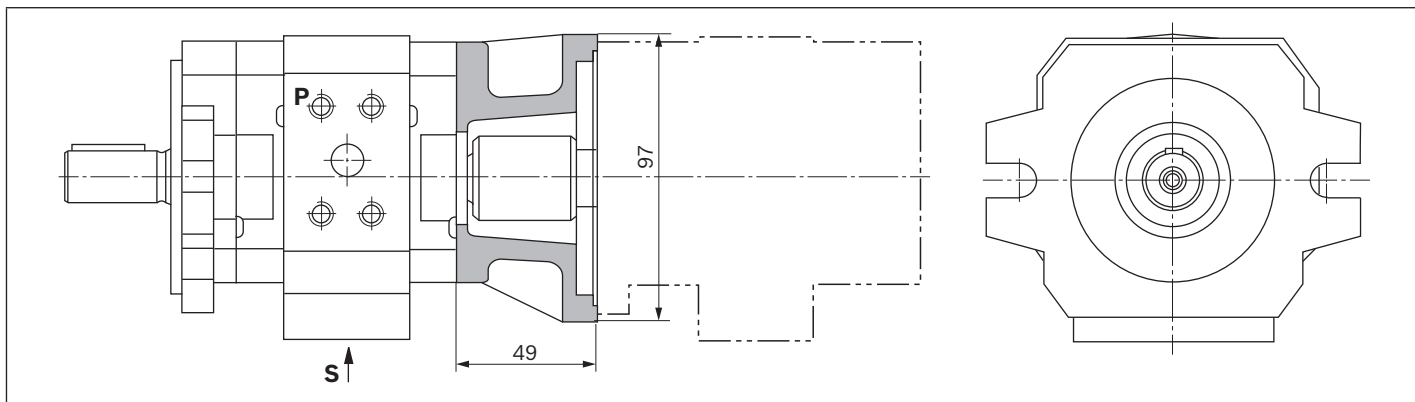

PGH2/PGH3 + R4-Mini

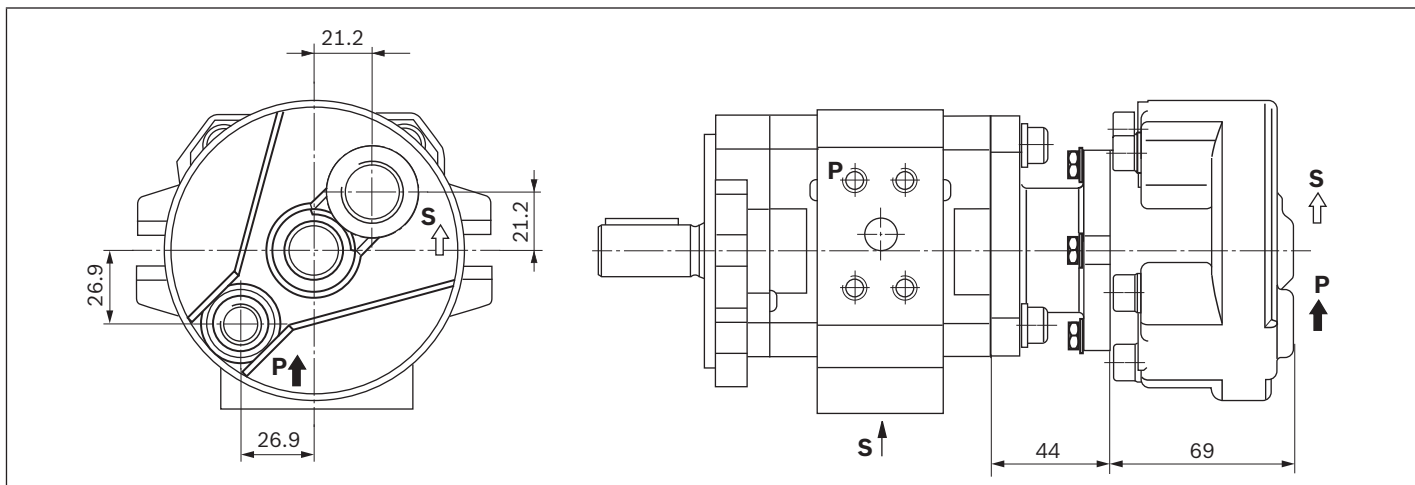

PGH2/PGH3 + PGZ

PGH2/PGH3 with combination part for PGZ4, PGZ5

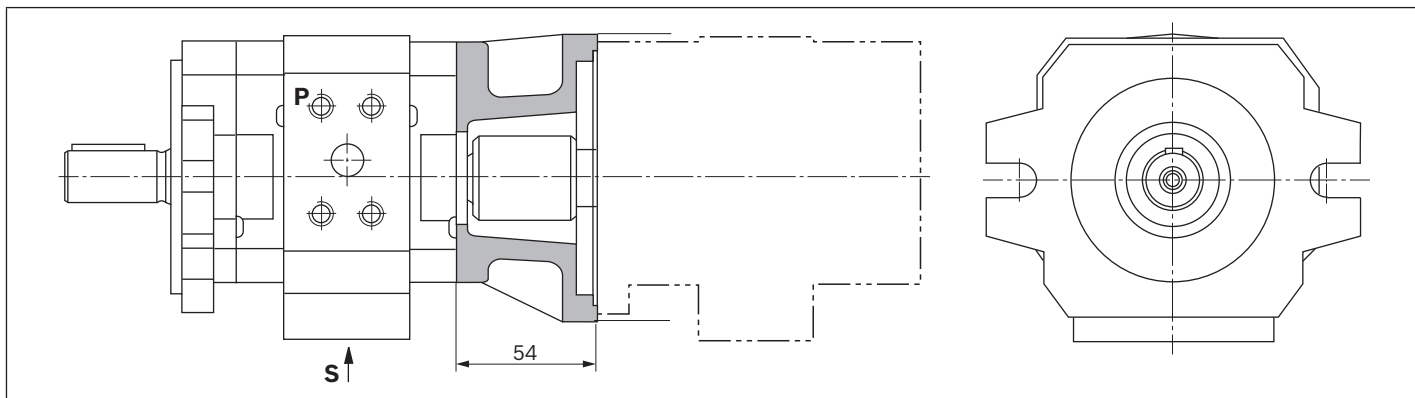

1) Dimensions of the single pumps see page 6 to 8 or the corresponding data sheets of the back pump.

Project planning information

When using internal gear pumps, a manual, switchable or automatic bleeding option must moreover be provided. The bleeding point for manual bleeding must be provided in the pressure line in front of the first valve or check valve so that depressurized bleeding is possible.

Technical data

All specified technical data depend on production tolerances and are valid at certain boundary conditions. Please note that consequently, fluctuations are possible and that with certain boundary conditions (e.g. viscosity), the technical data may also change.

Characteristic curves

When designing the drive motor, please observe the maximum application parameters possible shown by the characteristic curves presented on page 5.

Sound pressure level

The sound pressure levels shown on page 5 were measured in the style of DIN 45635, Sheet 26.

This means that only the noise emitted by the pump is shown. Ambient influences (place of installation, piping, etc.) were not included.

These levels always refer to only one pump.

With internal gear pumps, the excitation of valves, pipelines, machine parts, etc. is very low due to the little flow pulsation (approx. 2 to 3%).

With unfavorable influences, the sound pressure level at the place of installation of the power unit may, however, still be 5 to 10 db(A) higher than the values of the pump itself.

Multiple pumps

- ▶ The same general technical data apply as for single pumps (see page 4).
- ▶ The combined pumps must all have the same direction of rotation.
- ▶ The pump with the largest torque should be intended as first pump.
- ▶ The maximum through-drive torque must be checked by the project planner for every application. This is also true for already existing (coded) multiple pumps.
- ▶ The total of the torques in a multiple pump must not exceed the maximum drive torque.
- ▶ Joint aspiration is not possible.
- ▶ Before operating pump combinations with different hydraulic fluids, please consult Bosch Rexroth.
- ▶ Medium and back pumps must be equipped with drive shafts version "R" (geared).
- ▶ The drive torque of a pump stage is calculated as follows:

$$T = \frac{\Delta p \cdot V \cdot 0.0159}{\eta_{\text{hydr-mech}}}$$

Key

T	Torque [Nm]
Δp	Operating pressure [bar]
V	Displacement [cm ³]
η	Hydromechanical efficiency

▼ Maximum admissible torques [Nm]

Type	Drive torque			Output torque
	Cyl. shaft E	Splined shaft R	Splined shaft S	
PGH2	100	80	-	75
PGH3	110	80	155	75

Pump safety block

For limitation of the operating pressure or (and) for the solenoid-actuated unloading of the operating pressure, Bosch Rexroth recommends pump safety blocks according to the data sheets 25880 and 25891.

Installation information

Fluid tank

- ▶ Adjust useful volume of the tank to the operating conditions!
- ▶ The admissible fluid temperature must not be exceeded; include a cooler, if necessary.

Lines and connections

- ▶ Remove protective plugs from the pump.
- ▶ Select the inner width of the pipes according to the connections (suction speed 1 to 1.5 m/s).
- ▶ Inlet pressure see page 4.
- ▶ Thoroughly clean pipelines and fittings prior to installing.

Suggested pipe routing

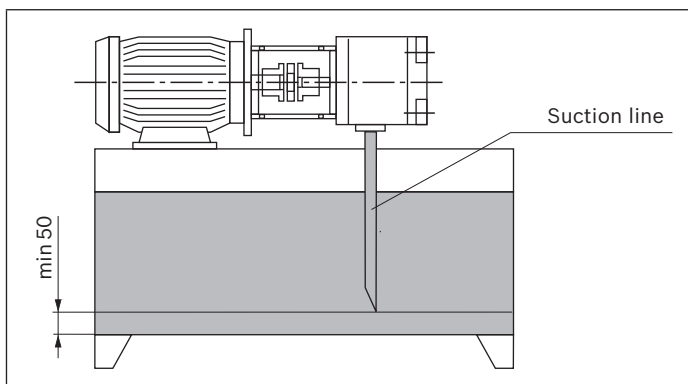

- ▶ Return fluid must not be directly sucked in again under any circumstances, i.e. select the largest distance possible between suction and return line.
- ▶ Suction line and return flow outlet must always lie clearly below the oil level.
- ▶ Ensure suction-tight assembly of the pipelines.

Filter

If possible, use return flow filters or pressure filters. (Only use suction filters in connection with underpressure switch / clogging indicator).

Hydraulic fluid

- ▶ Please observe our regulations according to data sheet 90220.
- ▶ Bosch Rexroth recommends brand hydraulic fluids.
- ▶ Different hydraulic fluid types must not be mixed as this might result in degradation and deterioration of the lubricity.
- ▶ According to the operating conditions, the hydraulic fluid must be renewed at certain time intervals. Residue should also be cleaned from the hydraulic fluid reservoir at this time.

Drive

Electric motor + pump carrier + coupling + pump

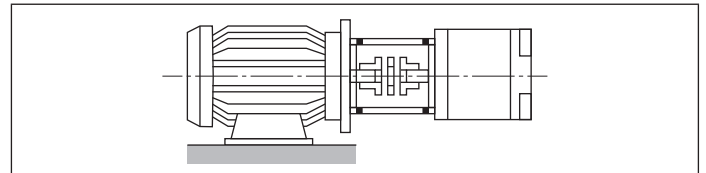

- ▶ No radial and axial forces on the pump drive shaft admissible!
- ▶ Motor and pump must be exactly aligned!
- ▶ Always use a coupling that is suitable for compensating shaft displacements!
- ▶ Avoid axial forces when attaching the coupling, i.e. **do not assemble it using impact tools or by pressing it on!** Use an internal thread of the drive shaft!

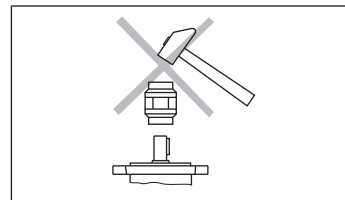

Installation positions

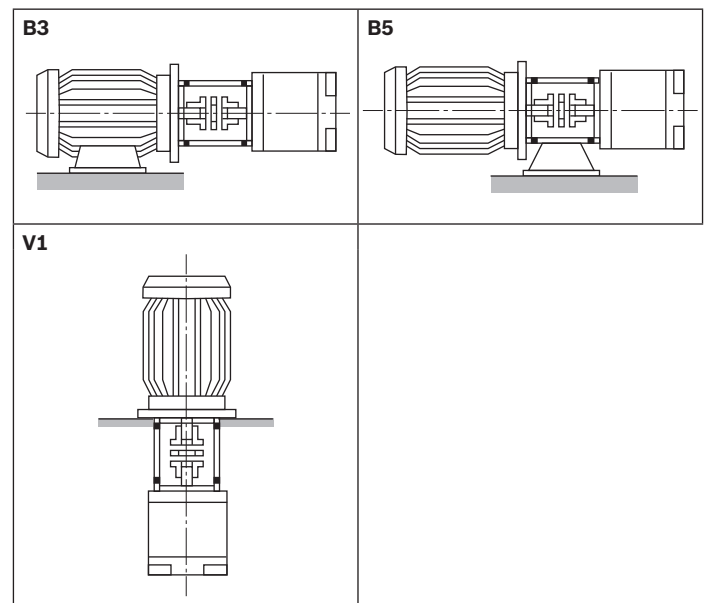

Commissioning information

Preparation

- ▶ Check whether the system is thoroughly and properly installed.
- ▶ Only fill in hydraulic fluid through filters with the required minimum retention rate.
- ▶ Completely fill the pump with hydraulic fluid through the suction or pressure pipe.
- ▶ Check the direction of rotation of the motor for compliance with the direction of rotation according to the pump type.

Bleeding

- ▶ Manually open the bleed port at the system or switch to depressurized circulation according to the operating instructions of the system. During the bleeding, depressurized discharge of entrapped air must be ensured.
- ▶ To bleed the pump, switch the motor on and immediately off again (jog mode). This process is to be repeated until complete bleeding of the pump is ensured.
- ▶ Close the manually opened bleed port again.

Commissioning

- ▶ If complete bleeding of the pump has been ensured, switch on the motor. Let the pump run at zero pressure until the system is completely bled. For system air bleeding, observe the operating instructions of the system.
- ▶ Commission the system according to the operating instructions of the system and load the pump.
- ▶ After some operating time, check the hydraulic fluid in the tank for bubble or foam formation at the surface.

Operation

- ▶ During operation, look out for changes in the noise characteristic. Due to the heating of the hydraulic fluid, slightly increasing noises are normal. A considerable increase in noise or short-time stochastic noise changes may be an indication of sucked in air. If suction pipes are too short or the filling level heights of the hydraulic fluid are too low, air may also be sucked in through a vortex.
- ▶ Changes in operating speeds, temperatures, increasing noises or power consumption are an indication of wear or damage at the system or the pump.

Re-commissioning

- ▶ Check the pump and system for leakage. Leaks are an indication of leakage below the hydraulic fluid level. An increased hydraulic fluid level in the tank is an indication of leakage above the hydraulic fluid level.
- ▶ If the pump is arranged above the hydraulic fluid level, the pump may run empty due to leakage, e.g. a worn shaft seal ring. In this case, the system must be bled again upon re-commissioning. Initiate the repair.
- ▶ After repair and maintenance works, bleeding is again necessary.
- ▶ If the system is intact, switch on the motor.

General information

- ▶ The pumps delivered by us have been checked for function and performance. The warranty only applies to the supplied configuration.
- ▶ Repair works may only be carried out by the manufacturer or their authorized dealers and agencies. The claim to warranty expires if the product is incorrectly repaired, assembled, commissioned and operated, not used as intended and/or handled improperly.
- ▶ Opening the internal gear pump or extending or modifying it will invalidate the claim to warranty.

Notes

- ▶ Assembly, maintenance and repair of the pump may only be carried out by authorized, trained and instructed personnel.
- ▶ Pump may only be operated with the admissible data (see page 4).
- ▶ Only operate the pump when in good working order.
- ▶ For all works at the pump, depressurize the system!
- ▶ Unauthorized modifications or changes which affect the safety and function are not admissible!
- ▶ Apply protective devices (e.g. coupling guard) and/or do not remove existing protective devices!
- ▶ Always ensure tight seat of all mounting screws (Observe the specified tightening torque)!
- ▶ The generally valid safety and accident prevention regulations must be imperatively complied with!

Bosch Rexroth AG

Industrial Hydraulics
Zum Eisengießer 1
97816 Lohr am Main, Germany
Phone +49 (0) 9352 / 40 30 20
my.support@boschrexroth.de
www.boschrexroth.de

© All rights reserved to Bosch Rexroth AG, also regarding any disposal, exploitation, reproduction, editing, distribution, as well as in the event of applications for industrial property rights.

The data specified above only serve to describe the product. No statements concerning a certain condition or suitability for a certain application can be derived from our information. The information given does not release the user from the obligation of own judgment and verification. It must be remembered that our products are subject to a natural process of wear and aging.