

Team Carrel

INSTRUCTIONS



01

ALIGN THE TEMPLATE

Set the back edge of the template flush to the back edge of the desk. Center the template side to side.

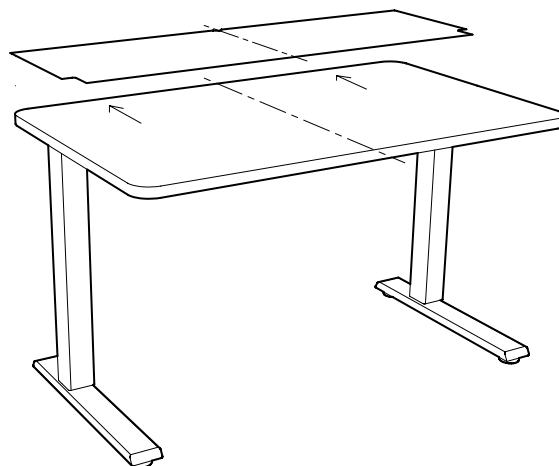

02

STICK YOUR FEET

Remove the backing on the Team Carrel's self adhesive Registration Feet and place them in the openings on the template. Press firmly to adhere.

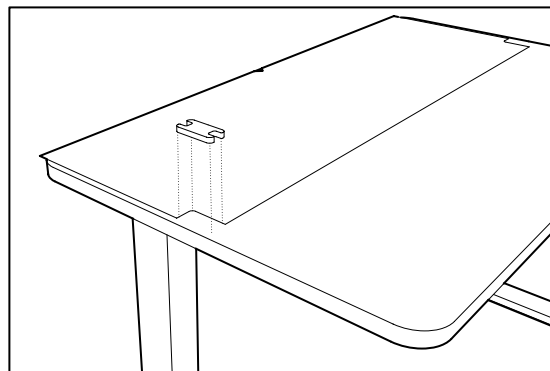

03

DROP IT IN

Remove the template and lower the Team Carrel onto the desk so that the indentations on the carrel align with the Registration Feet. Voila!

