

EXPOSED IN THE OPEN WORKPLACE?

Find shelter with a Team.

The Team Carrel is a refined and functional desktop shelter optimized for high-density benching and shared table setups. Lightweight and reversible, it's a great solution for open plan offices and smaller workstations, creating a renewed sense of personal space without sacrificing elegant design.

KEY FEATURES



Store Flat



No Holes
Needed



Reversible



*Shown in Slate Fiberboard/Pebble Forbo

SOPHISTICATED SIMPLICITY

Team Carrels feature a one-piece design with innovative living hinges, and are provided with an installer-friendly location template, making tool-free setup a snap. Available in a suite of luxurious finishes, including dual-material versions that can be quickly reversed for a new look, there's a Team Carrel to compliment any workplace.

SPECIFICATIONS

MATERIAL OPTIONS

SINGLE MATERIAL



Acoustic Felt



Charcoal



Heathered Grey

DUAL MATERIAL



Forbo

+



Iron



Pebble



Mushroom



Color Fiberboard



Slate



Fog



Europly



Walnut



White Oak



Classic Birch

INQUIRES

Team Carrels can be ordered through select dealers in the US, or direct from Second Space if we don't have a dealer in your area. If you'd like to locate a dealer, make an order inquiry, or just get some more information, please contact us at lets.talk@second-space.co.

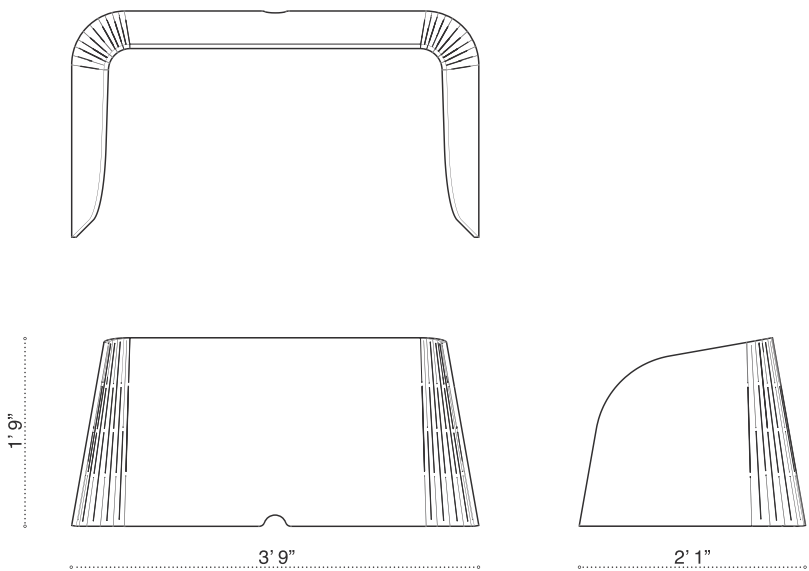

*Shown in Charcoal Acoustic Felt

EXAMPLE CONFIGURATIONS

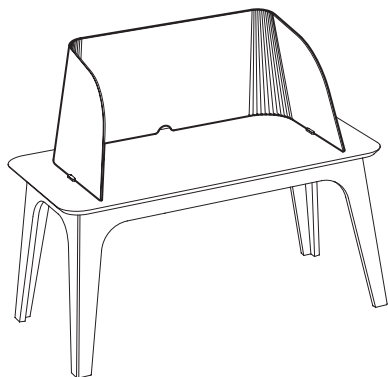

EXAMPLE INDIVIDUAL DESK

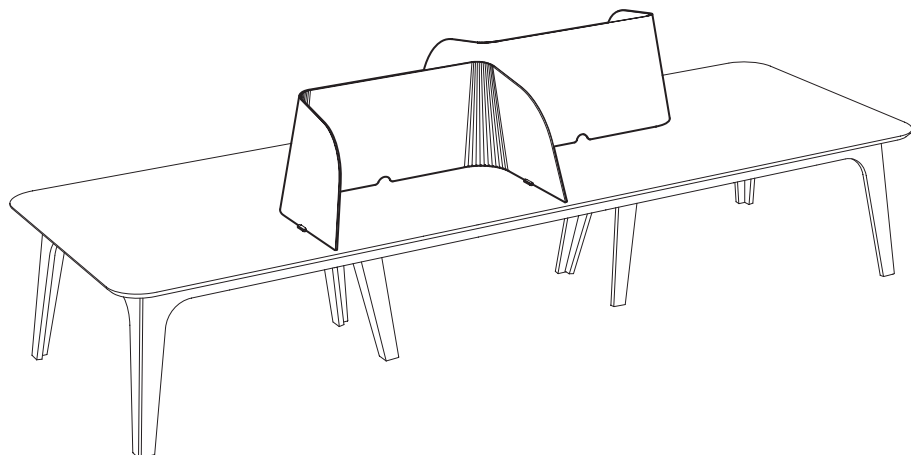

EXAMPLE COMMUNAL TABLE

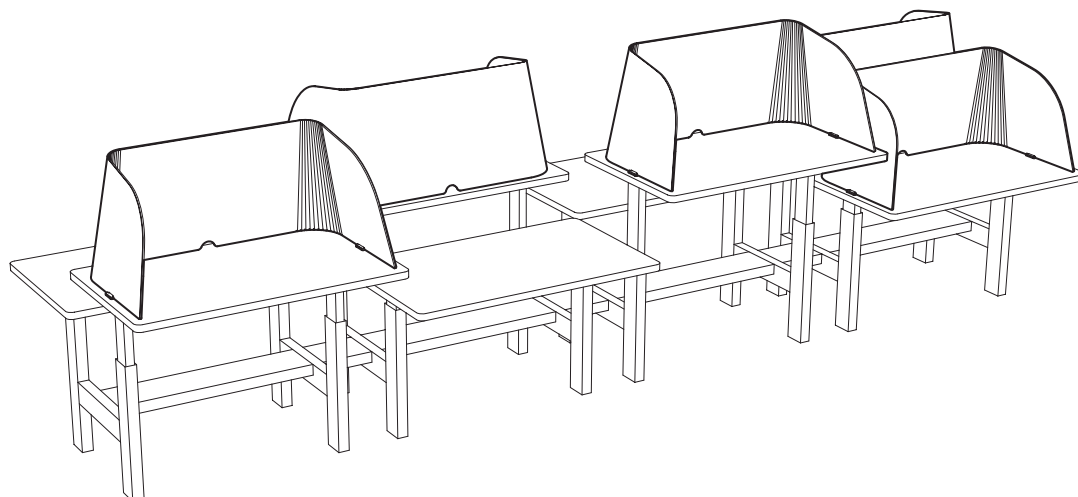

EXAMPLE BENCHING