

Adaptive Carrel System

INSTRUCTIONS

DESK MOUNT INSTALLATION

01

Place provided mounting template on desk in desired location.

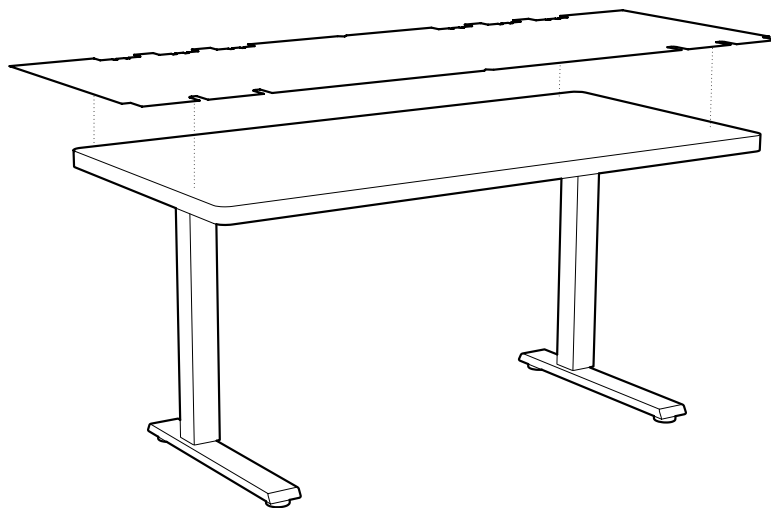

02

Peel and Install Wing Mount Bracket and Desk Mount Bracket, adhering them to desk surface in the locations indicated by the template. Press down firmly to seat the pressure sensitive adhesive.

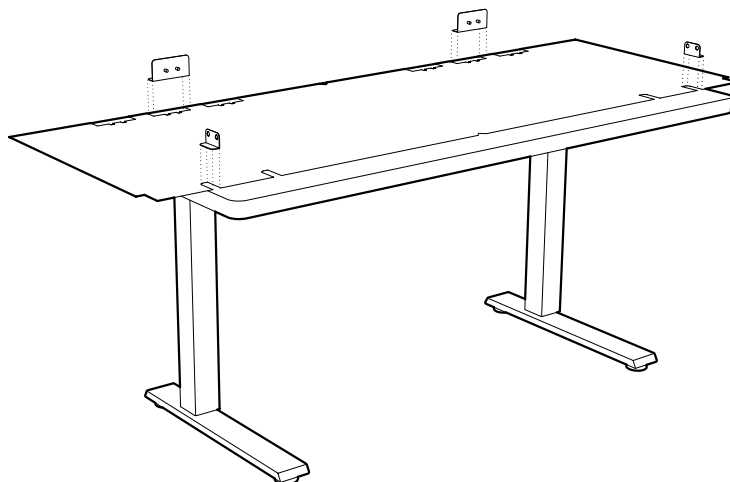



PANEL CONNECTOR INSTALLATION

01

Choose an adequate workspace. This should be a large, empty worksurface, or even a clean area of floor. Press Connector Plate standoffs into holes on from the desired EXTERIOR side of the Back Panel.

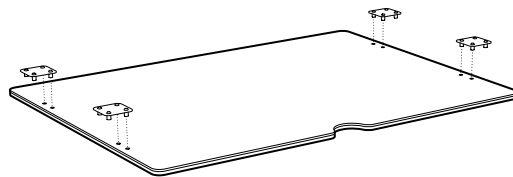

02

Turn Back Panel over showing the desired INTERIOR material facing up. Then press Wing Panel onto open Connector Plate standoffs.

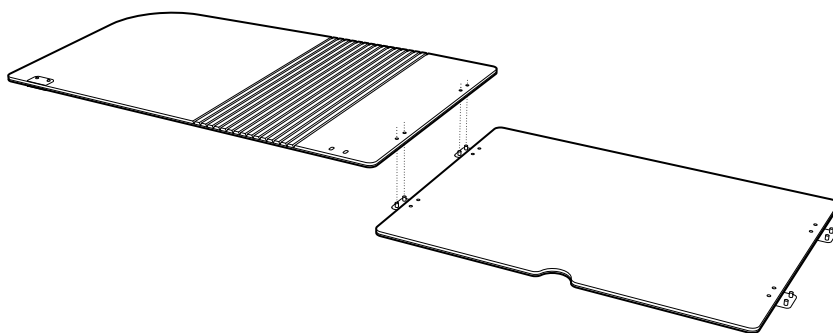

03

Install other side of Connector Plates for the installed Wing. FULLY TIGHTEN THESE SCREWS WITH HEX KEY PROVIDED.

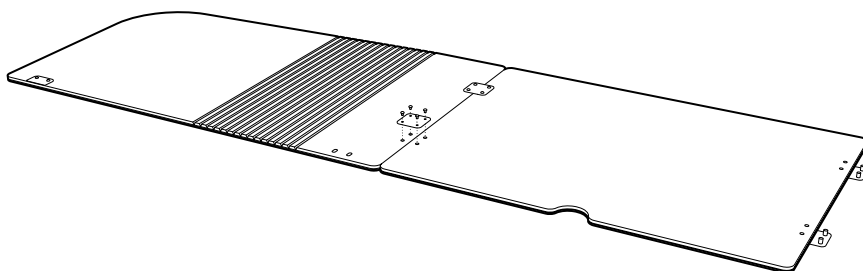

04

Fold Wing Panel to center. Repeat steps 2-4 for other Wing installation.

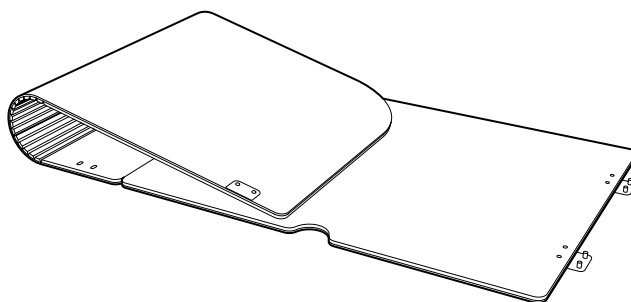



PRODUCT INSTALLATION

01

Slide slots in Wing Panels onto the protruding Exterior Desk Mount Bracket standoffs.

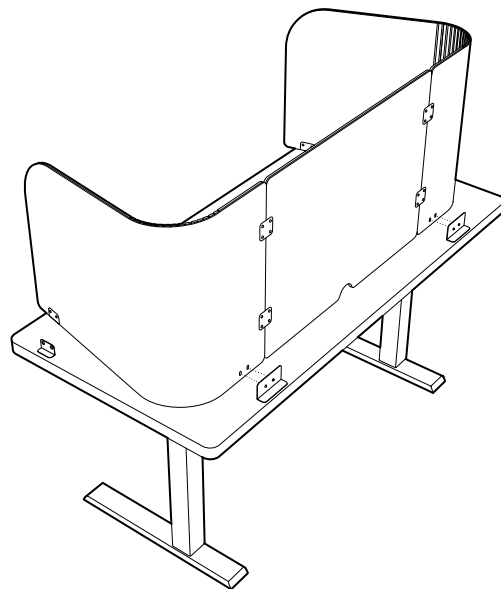

02

Align Wing Plates with Wing Mount Brackets, connecting them with the integrated magnet.

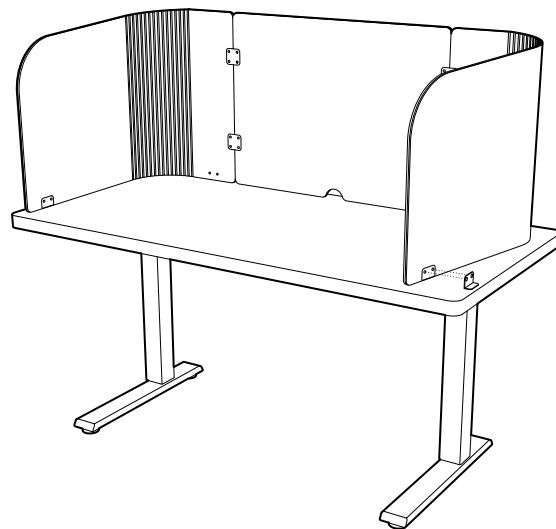

03

Screw Interior Desk Mount Plates onto standoffs. FULLY TIGHTEN THESE SCREWS WITH HEX KEY PROVIDED.

