

WORKPLACE NEEDS IN FLUX?

Adapt with ease.

The Adaptive Carrel System is a component-based solution that creates personal space to focus at workstations of multiple sizes. Designed to simplify the management of fluctuating office capacity, it features extended-depth end panels that hinge inward to signal a 'closed' status for workstations not in use, a boon for hot-desking environments and workforce spacing. Plus, its modular nature allows it to reconfigure with the changing needs of your office.

KEY FEATURES



No Holes
Needed



Modular



Open/Close
Capability



*Shown in Walnut Europly/Pebble Forbo

CHANGE WITH THE TIMES.

The Adaptive Carrel System is our most versatile worksurface partition, featuring modular components to suit any desk size. In addition to our unique Deep Wings that close to signal unused workstations, the system also features back panel options to accommodate a wide range of hardware, from laptops and tablets to monitor arrays. Add a palette of diverse material choices and thoughtfully designed hardware that's easily installed on any substrate, and you've got a solution with the flexibility to grow along with your business.

SPECIFICATIONS

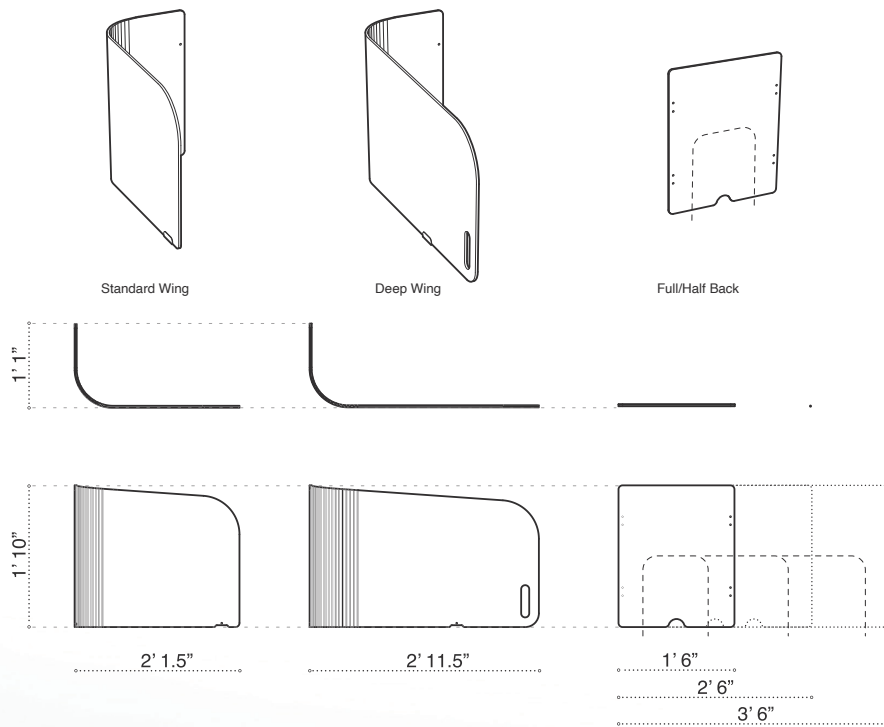

MATERIAL OPTIONS

SINGLE MATERIAL



DUAL MATERIAL

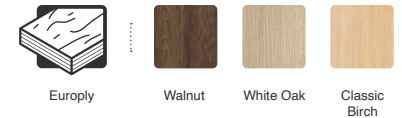
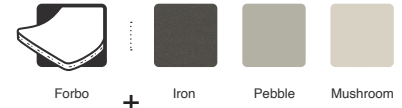

INQUIRES

The Adaptive Carrel System can be ordered through select dealers in the US, or direct from Second Space if we don't have a dealer in your area. If you'd like to locate a dealer, make an order inquiry, or just get some more information, please contact us at lets.talk@second-space.co.



*Shown in Fog Fiberboard/Iron Forbo

EXAMPLE CONFIGURATIONS

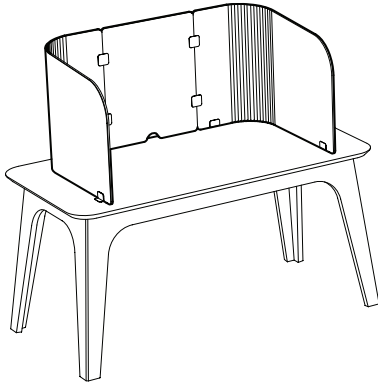

EXAMPLE INDIVIDUAL DESK (48" / Full Back / Standard Wings)

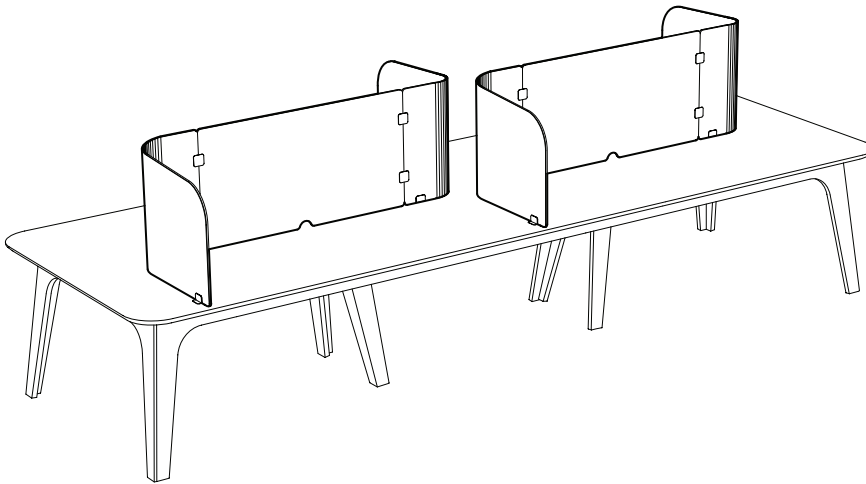

EXAMPLE COMMUNAL TABLE (72" / Full Back / Standard Wings / Zig Zag)

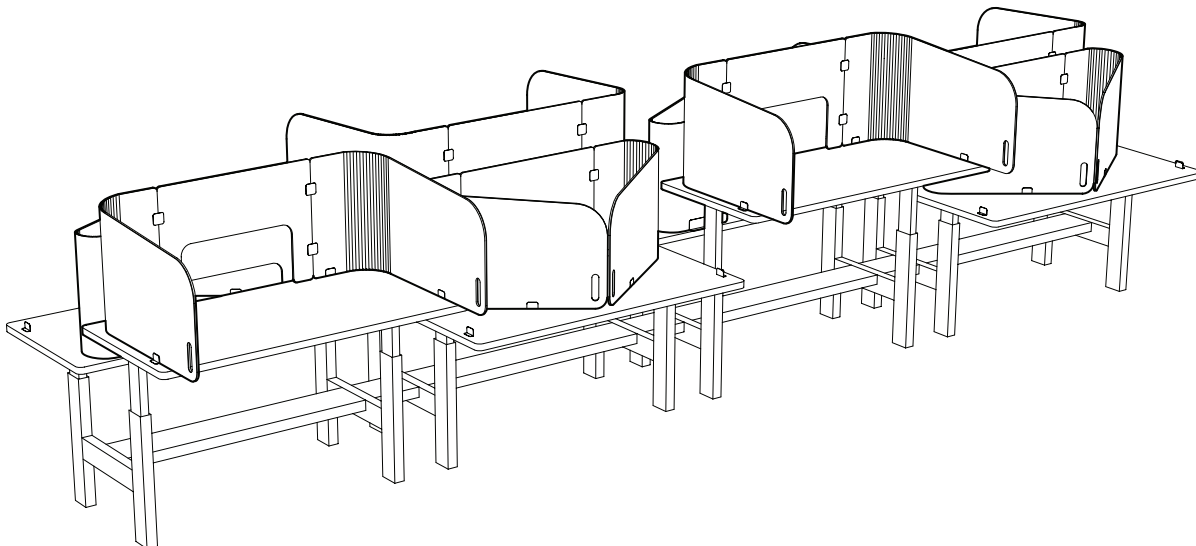

EXAMPLE BENCHING (60" / Half Back / Deep Wings / Open-Close)