



baby hammock owner's manual



natural materials



no harmful synthetics



earth friendly



age: newborn

A smooth transition from womb to world.

A Nature's Sway baby hammock's gentle movement and snug embrace, naturally soothes your baby by simulating the familiar sensation of being carried by their mother. That comforting feeling helps your baby drift off to sleep, and even stay asleep longer.



**made in
new zealand**

WARNING: Please take the time to read this booklet carefully. It is extremely important to ensure correct assembly and use, to reduce the risk of harm to your baby. Incorrect use can present a risk of suffocation. We ask that you trust your instincts as a parent to keep your baby safe but if you are in any doubt about anything to do with your baby hammock, please contact us at hello@naturesway.co.nz.

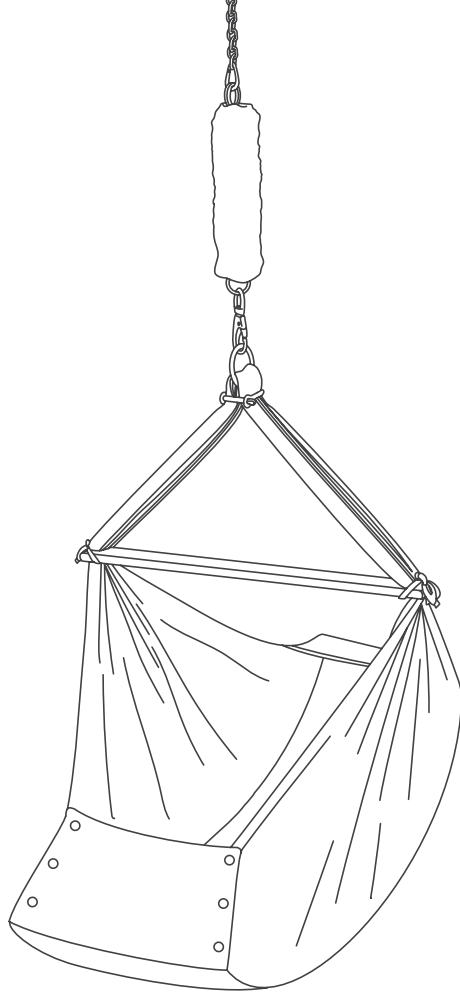

Congratulations!

You have chosen a product to help your baby transition from womb to world as smoothly as possible. We appreciate the confidence you have expressed in the Nature's Sway brand by choosing one of our hammocks for your precious baby.

Since 1993, we have endeavoured to create reliable, high quality products using carefully sourced materials and we back our products with a 2 year warranty (conditions apply - see back page).

contents

safety checklist	page 4
suspension options.....	page 5
setting up your baby hammock.....	page 6
placing your baby in the hammock.....	page 8
care instructions	page 9
baby hammock accessories	page 10

safety checklist ✓

1. **When a child is able to roll, sit, kneel or to pull themselves up, the hammock is no longer safe and should not be used.**
2. Always place your baby on their back in the hammock. Never place your baby on their side or front.
3. Always ensure that your baby's chin is not resting on their chest, so that their airways are unobstructed.
4. Always ensure that your hammock is correctly used and assembled, according to these instructions.
5. Always monitor your baby when using the hammock and stay close by.
6. Always ensure that the wooden spreader beam is well secured and perfectly horizontal.
7. Always ensure that the D-Shackle is closed tightly and centred on the hammock body. (See page 6)
8. Always ensure all clips and carabiners are securely closed.
9. Never leave young children unsupervised around your hammock.
10. Never place anything in the hammock that could cover your baby's face or interfere with breathing.
11. Never bounce or sway your hammock vigorously.
12. Never use any parts or accessories from other manufacturers.
13. Never use your hammock if parts are broken, torn, frayed or missing.
14. Never place your hammock near any fire, oven, stove or heater.
15. Never suspend your hammock from any fixture not recommended by Nature's Sway.
16. The lowest part of your hammock should be no higher than 500mm from the floor.
17. Maximum weight is 15kg (33 lbs).

suspension options

Ceiling screw

Our stainless steel coach eye ceiling screws are designed to hang your hammock from a solid wooden beam or ceiling joist. We recommend you use a stud detector or consult a building professional before installing.

Installation

1. Drill a pilot hole, into the centre of the beam. (4mm diameter, 40mm depth)
2. Insert the ceiling screw and tighten until the thread is no longer visible.
3. **Make sure the ceiling screw can hold the weight of an adult *before* hanging the hammock.**

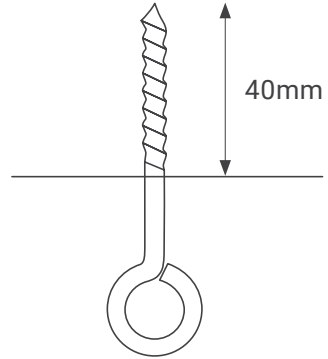

Door frame clamp

Our door frame clamp is designed to clamp above standard door frames only.

Requirements

1. Minimum wall thickness – 75mm.
Maximum wall thickness – 150mm.
2. Minimum flat surface – 15mm.
3. Never use the door frame clamp on a door frame that is not flat and horizontal or is worn, broken or damaged.
4. Never swing your hammock while on a door frame clamp, use for gentle bouncing motion only.
5. Make sure the door frame clamp is secure before use.

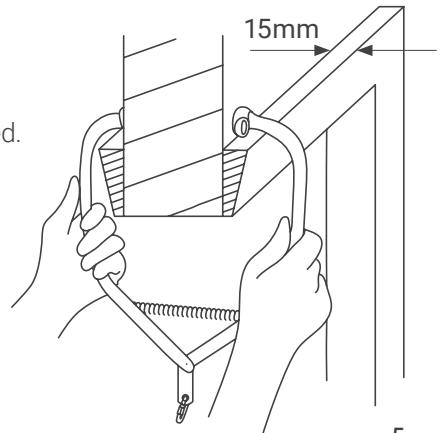
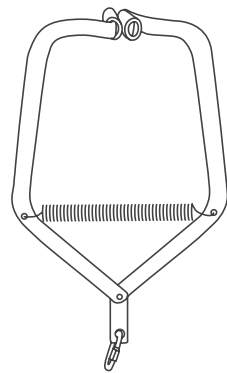

setting up your baby hammock

Parts

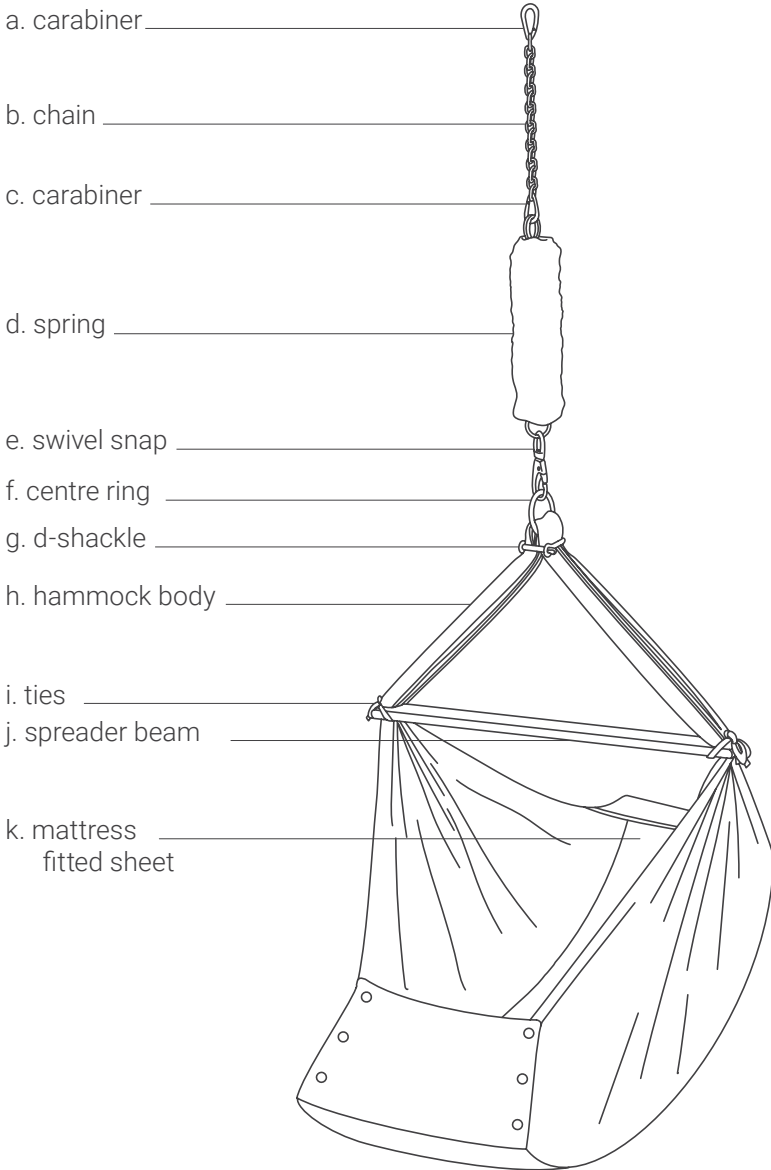

setting up your baby hammock

1. Closely inspect the hammock body and all other parts for any damage during shipping or storage.
2. Hang the chain (b.) from your chosen suspension point (see suspension options on page 5) using a carabiner (a.) at the top and at the bottom (c.).
3. Hang the spring from the bottom carabiner making sure the swivel snap (e.) is at the bottom.
4. Hang the hammock body (h.) by attaching the centre ring (f.) to the swivel snap. Make sure the d-shackle (g.) is closed tight and holding the centre ring securely in the centre of the hammock body.
5. Gather the sides of the hammock body and ensure the two ties (i.) are exactly equal distance down from the centre ring.
6. Tightly gather the fabric at the ties and tie them around the gathered fabric once. Push the gathered fabric into the two notches on either end of the spreader beam (j.) just above the ties.
7. Wrap the ties diagonally up over the spreader beam and tie in a secure bow. Check that the spreader beam is perfectly horizontal and securely in place.
8. Cover the mattress (k.) with the baby hammock fitted sheet and place it in to the hammock body, ensuring it is positioned squarely and evenly in the centre of the hammock body. Adjust the hammock body until there are no creases or folds below the mattress.
9. Adjust the chain length if necessary by moving the carabiners on the chain, to get the hammock to the required height.

How to tie the spreader beam.

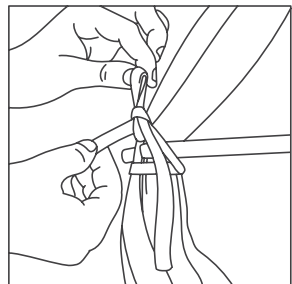
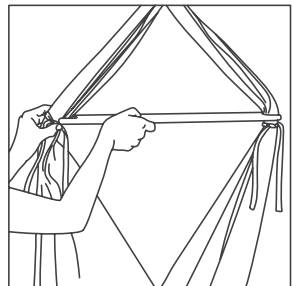
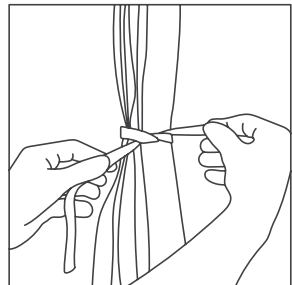
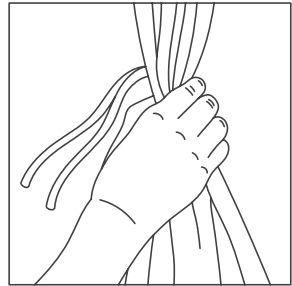

Video instructions available at naturesway.co.nz

placing your baby in the hammock

- Place your baby on their back in the centre of the hammock.
- Ensure that your baby's chin is not resting on their chest and that their airways are unobstructed.
- One of the features of the hammock is that it makes the baby feel like they are being held, so expect to see the baby's weight pull the fabric into gentle folds around their head and body.

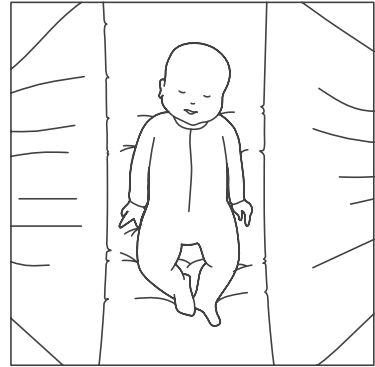

- As your baby grows they may require a stiffener underneath the mattress to make the hammock base firmer. The Nature's Sway coconut fibre mattress stiffener is recommended for babies over 4kg and is sold separately.
- On average, babies use the baby hammock for their first six months. Around this age when their bodies start to strengthen, they naturally require less movement and most babies make the transition to a still, flat bed easily. When a child is able to roll, sit, kneel or to pull themselves up, the hammock is no longer safe and should not be used.
- Pay close attention to your baby and always stay close by.
- Do not put excessive layers of clothing or bedding on your baby, as there is a danger of your baby overheating. The Nature's Sway wool mattress offers natural insulation and helps regulate your baby's body temperature.
- Position your baby so their head is not lower than their feet. A newborn's head and body proportions can sometimes cause their head to tilt lower than their feet in the baby hammock. If this happens, place a small weight under the mattress at the foot end to slightly elevate the head end. This can also be a good position for babies prone to reflux.
- Place your hammock and baby in a draught free area, with no obstacles below or around the hammock.

care instructions

Hammock

We recommend you wash the hammock body before use.

1. Remove the d-shackle (g. on page 6)
2. Cold, gentle, machine wash with the centre ring still attached (f. on page 6). Do not bleach.
3. Medium iron when hammock is still damp. Do not iron on logo print.
4. Hang to dry. Do not tumble dry.
5. When the hammock is dry, gather the fabric neatly and re-attach the d-shackle.

It is very important to make sure that the d-shackle is holding the centre ring firmly in the centre of the hammock body. If the centre ring is not centred on the hammock body, the hammock's mattress will not be level which can cause your baby to roll.

Please note: The exact shade of cotton colour may vary. Small marks or slight slubs in the fabric are also not uncommon and will not effect the function of the baby hammock in any way.

Sheets

We recommend you wash the hammock sheets before use.
Cold machine wash, hang to dry or tumble dry, hot iron.

Wool mattress

Gentle surface wash only. If the wool mattress gets completely submerged in water, it tends to compact and be permanently altered, which our warranty does not cover. We also have a 100% wool mattress protector which is sold separately. We recommend replacing your hammock's mattress for each new baby that uses the hammock.

Please note: Sometimes, upon opening a new mattress, a faint smell can be detected by those of us with very sensitive noses. This is just the residual smell of the lanolin in the wool and with a little air and sunshine, it will quickly subside.

Storage

Store your hammock and all parts in a dry, pest-free environment.

accessories

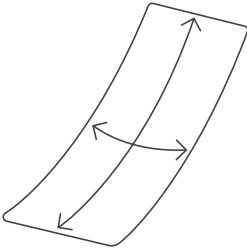

Mattress stiffener

As your baby grows they may require a stiffener underneath the mattress to make the hammock base firmer and more open. We recommend them for babies 4kg and over. Made from coconut husk fibre.

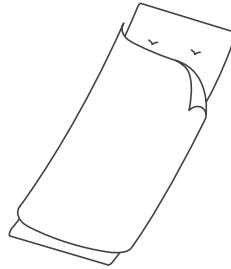

Mattress protector

Nature's Sway Mattress Protectors are made in New Zealand using 100% NZ wool. The natural lanolin provides the waterproofing and requires minimal care.

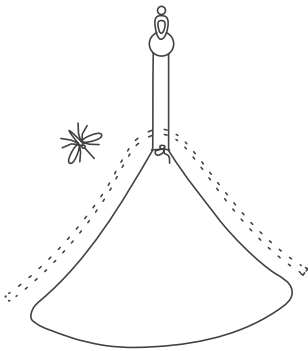

Mosquito net

Our mosquito nets are made from a beautifully soft silk georgette. The sheer, breathable fabric is perfect to keep mosquitoes and other insects out, for a peaceful sleep.

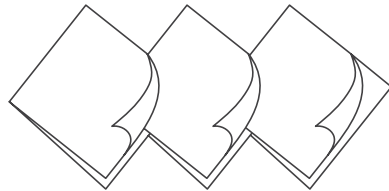

Hammock sheets

Extra sheets are sold separately. Available in summer and winter cotton fabrics.

accessories



A hammock stand is the perfect compliment to your baby hammock and it ensures that your baby can rest peacefully wherever you are. They are easy to assemble and dismantle for storage and portability.

Beechwood hammock stand

Made in New Zealand from locally and sustainably grown red and silver beech trees.

Assembled Height: 1.78 m
Assembled Footprint: Approx. 1 m²

Steel hammock stand

Made in New Zealand from strong steel tubing and finished with durable powder coating.

Assembled Height: 1.88 m
Assembled Footprint: Approx. 1 m²



Manufactured by Nature's Sway Ltd in Auckland, New Zealand.

Ph 09 8382374. Email: hello@naturesway.co.nz
www.naturesway.co.nz

2 YEAR Warranty

Conditions: The warranty is subject to proper assembly, installation and use according to this owner's manual. The warranty will be void if the instructions are not followed or products are subjected to abuse, negligence, improper use, inappropriate adaptation, or the hammock is attached to equipment other than that manufactured by Natures Sway.

Please note: The Natures Sway wool mattress is exempt from the 2 year warranty. We guarantee the mattress against manufacturer's faults for 6 months but because it is made using only natural materials (wool and cotton), the mattress will naturally compact with use and requires special washing procedures. We recommend that a new mattress is used for each new baby.

Retain your sales receipt and record your date and place of purchase.

Nature's Sway baby hammocks and parts have been thoroughly strength tested on a 158 tonne computerised testing bed, calibrated by Australian Calibrating Services. All parts have a minimum working weight of 75kg and a breaking weight of no less than 150kg. Our springs have been fitted with a safety strap, allowing a maximum movement of 30cm. Please be aware; because we don't use any potentially harmful bleaches or dyes, your hammock's exact shade may vary slightly.