

INVISI™

SERIES II

4.5/3 litre concealed cistern
237007, 237003 and 237004

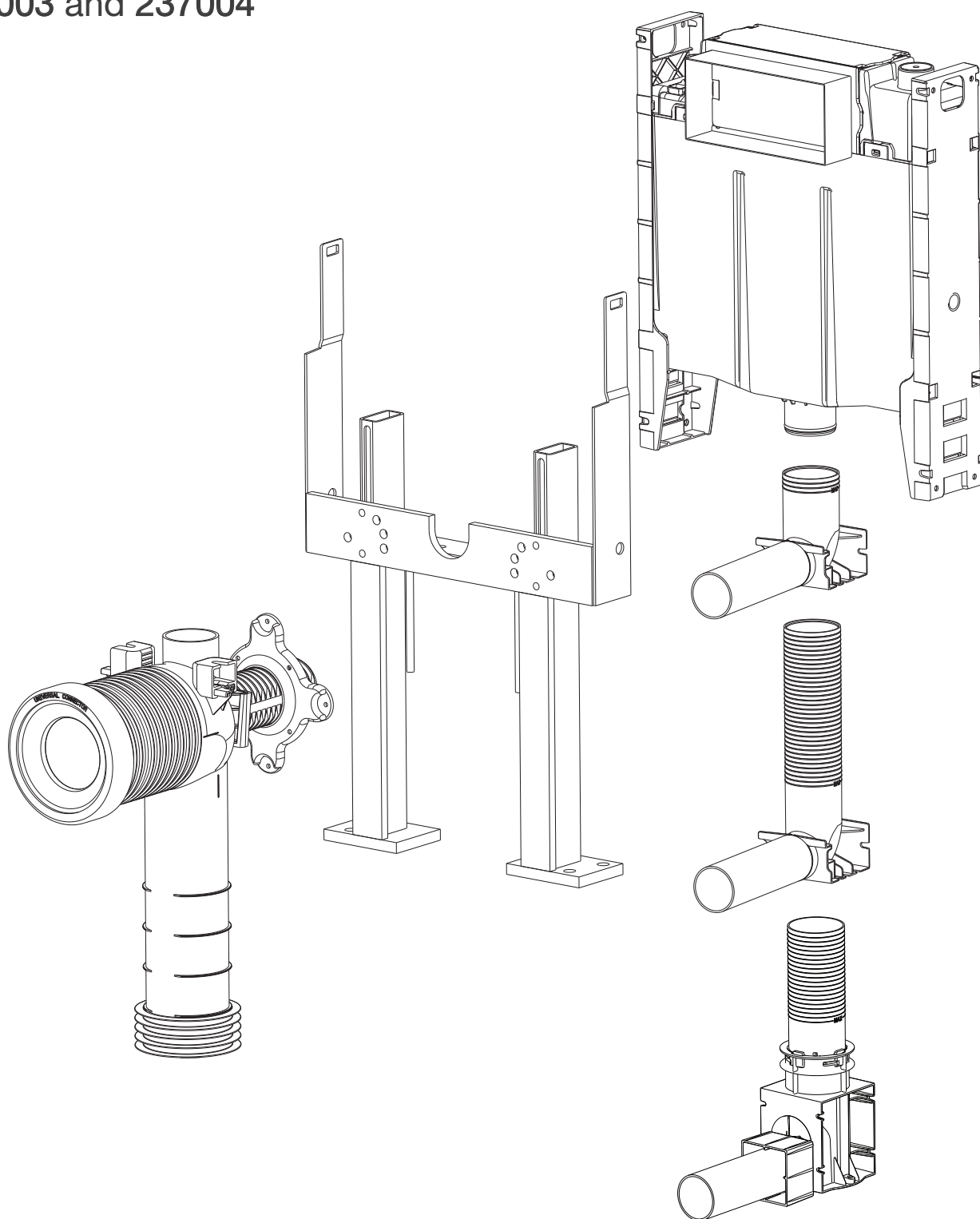

| | |
|--|----|
| Adjustable Flush Pipe Assembly | 2 |
| 5 Step Easy Install | 3 |
| Installation Requirements | 3 |
| Cistern Service Access Options | 4 |
| Button Mounting Options | 5 |
| Installing the Cistern - 237 007 | |
| Inwall Access - stud wall | 6 |
| Inwall Access - masonry wall | 7 |
| Induct Access | 8 |
| In Ceiling Access | 9 |
| Under Counter Access | 10 |
| Custom Panel Access | 11 |
| Installing the Cistern - 237 003 | |
| Inwall Access | 12 |
| Induct Access | 14 |
| In Ceiling Access | 15 |
| Where removal of the cistern may be required | 16 |
| Where adjustment of the cistern height is required | 16 |
| Installing the Cistern - 237 004 | |
| Under Counter Access | 17 |
| Optional Remote Mounting Box Kit - 237 006 | 18 |
| Access Panel Variations | 19 |
| 6/3 Litre Conversion | 19 |
| Preparation for Fitout | 20 |
| Removing Internal Components through Access Window | 21 |
| Adjustable Flush Pipe Feature - 237 007 | 22 |
| Servicing - Outlet Valve | 23 |
| Servicing - Inlet Valve | 24 |
| Important Notices | 24 |
| Helplines | 24 |

Adjustable Flush Pipe Assembly

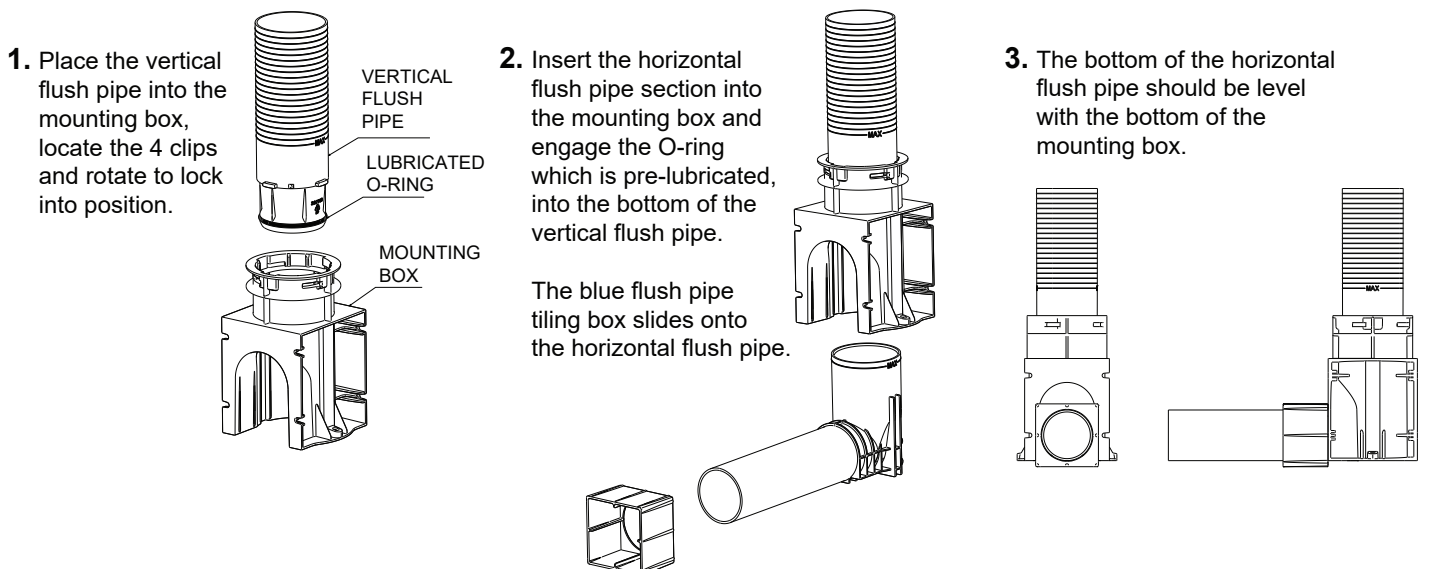

5 Step Easy Install

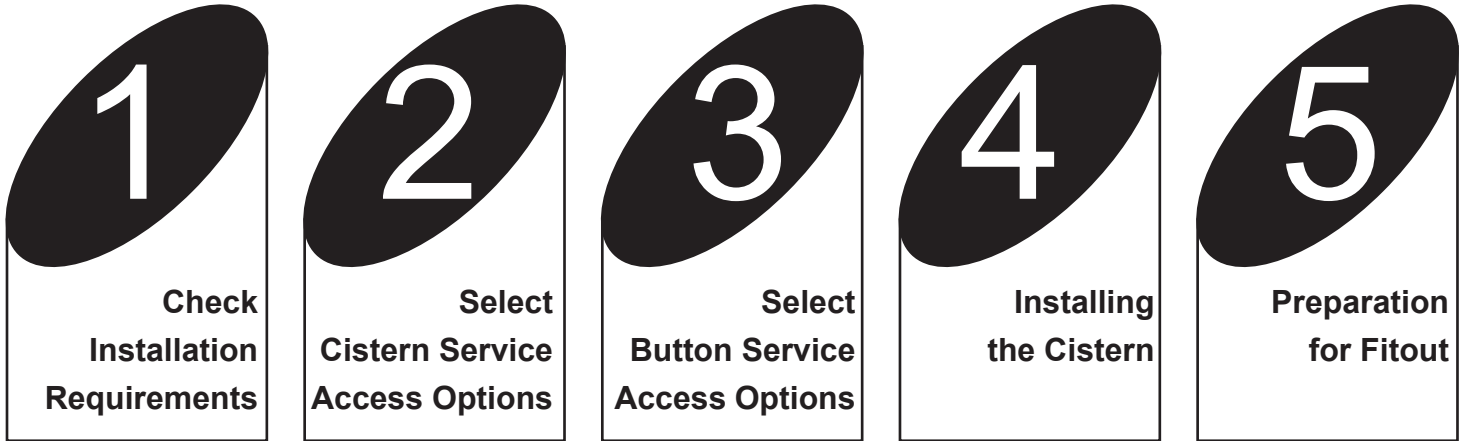

Installation Requirements

237 007 - Invisi II 4.5/3L Dual Flush Cistern with Adjustable Flush Pipe

CONTENTS

- Invisi II - 4.5/3L Concealed Cistern
- Mounting Brackets
- Adjustable Flush Pipe
- 0.5m of Pneumatic Tube
- Cistern Fixing Pack

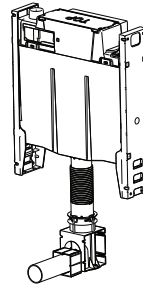

REQUIREMENTS

- 90mm Min Inwall Cavity Depth
- 400mm Min - 420mm Max Cavity Width (e.g. between studs)
- 1/2 inch BSP Water Connection

237 003 - Invisi II 4.5/3L Dual Flush Cistern - with Standard Wall Hung Pan Bracket

CONTENTS

- Invisi II - 4.5/3L Concealed Cistern
- Mounting Brackets
- Inwall, Wall Hung Pan Bracket
- Tall Flush Pipe
- 0.5m of Pneumatic Tube
- 90mm Waste Pipe
- Pan Bracket Fixing Pack

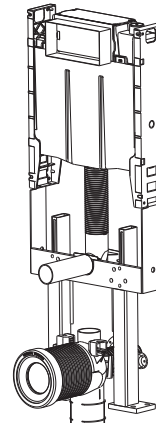

REQUIREMENTS

- 90mm Min Inwall Cavity Depth
- 400mm Min - 420mm Max Cavity Width (e.g. between studs)
- 1/2 inch BSP Water Connection

237 004 - Invisi II 4.5/3L Dual Flush Cistern - with Under Counter Wall Hung Pan Bracket

CONTENTS

- Invisi II - 4.5/3L Concealed Cistern
- Mounting Brackets
- Under Counter, Wall Hung Pan Bracket
- Short Flush Pipe
- 0.5m of Pneumatic Tube
- 90mm Waste Pipe
- Pan Bracket Fixing Pack

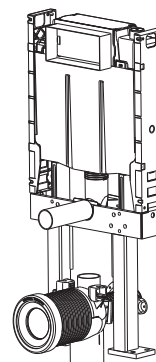

REQUIREMENTS

- 850mm Min Height to under counter
- 90mm Min (Front Mount Button Panel)
- 100mm Min (Top Mount Button Panel)
- Inwall Cavity Depth
- 400mm Min - 420mm Max Cavity Width (e.g. between studs)
- 1/2 inch BSP Water Connection

Inwall Access

This allows access to cistern internals through the button panel window. Standard installation requires no change to product configuration.

An optional Remote Mounting Box Kit (*refer to page 18*) is required if using Remote Button Panel and or extending the flush pipe .

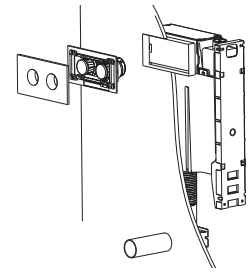

In duct Access

This allows access to the whole cistern. Standard installation will require Remote Mounting Box Kit (*refer to page 18*) for use with Remote Button Panel.

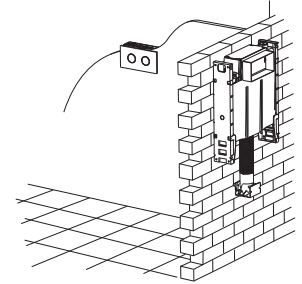

In Ceiling Access

This allows access to the whole cistern or access to cistern internals through the panel window depending on installation. Standard installation will require Remote Mounting Box Kit (*refer to page 18*) for use with Remote Button Panel.

Optional Top Access will require the access panel to be converted (*refer to page 19*).

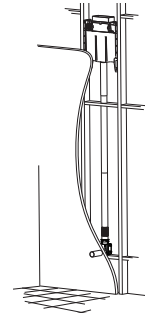

Under Counter Access (*optional under counter flush pipe 237222 is required*)

This allows access to cistern internals through the button panel window. Standard installation requires no change to product configuration.

Optional Top Access will require the access panel to be converted (*refer to page 19*).

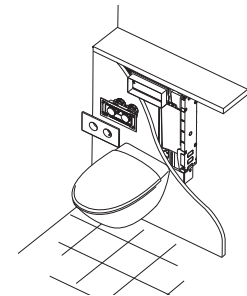

Large Panel Access

This allows access to the whole cistern. Standard installation requires no change to product configuration.

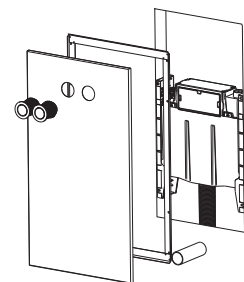

Custom Panel Access

This allows access to the whole cistern or access to cistern internals through the panel window depending on installation.

An optional Remote Mounting Box Kit (*refer to page 18*) is required if using Remote Button Panel and or extending the flush pipe.

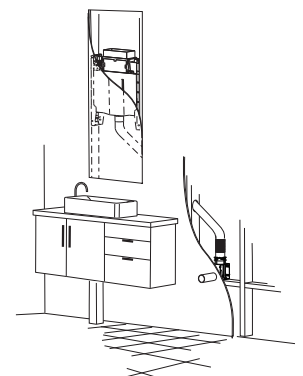

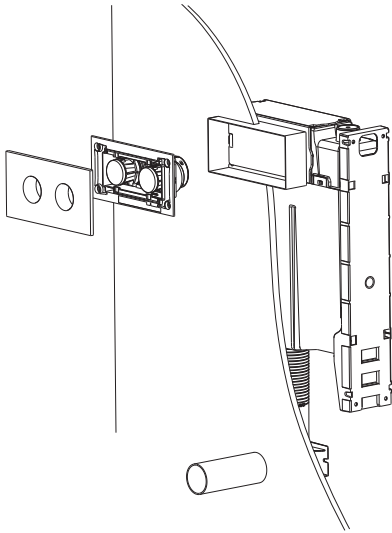

Direct Panel Mounting - Front

This is suitable for use with any of the button panel kits.

Requires a 5mm minimum - 45mm maximum total cladding thickness.

Access to the cistern internals is provided through the panel window.

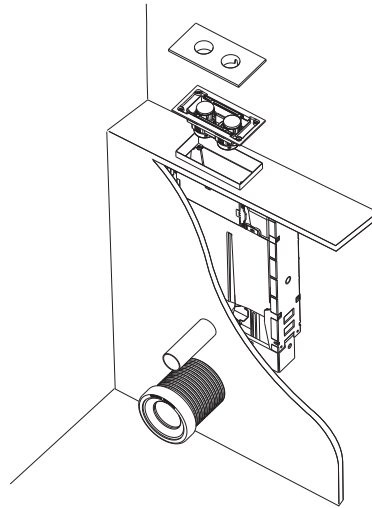

Direct Panel Mounting - Top (Under Counter)

This is suitable for use with any of the button panel kits.

Requires a 5mm minimum - 45mm maximum total cladding thickness.

Access to the cistern internals is provided through the panel window.

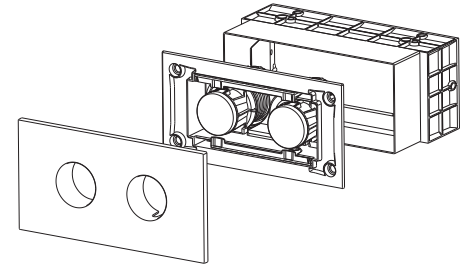

Remote Panel Mounting

This is suitable for use with any of the button panel kits.

Suits up to 45mm maximum total cladding thickness.

A Blanking Panel is required for inwall access to cistern internals.

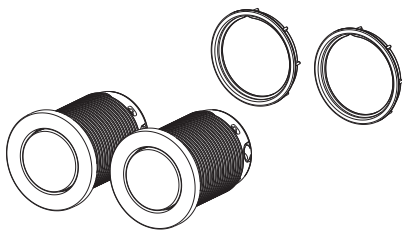

Remote Button Mounting

Access to the rear of the buttons must be provided for servicing.

Suitable for mounting through panels up to 55mm thick.

A Blanking Panel is required for inwall access to cistern internals.

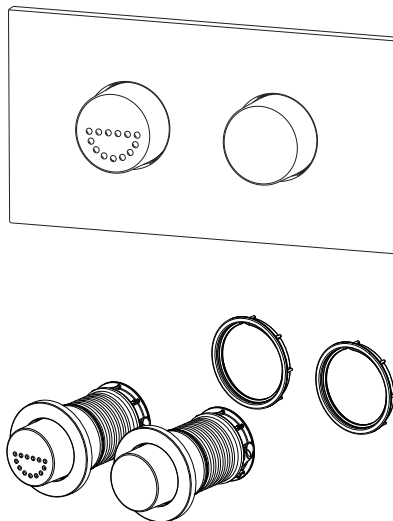

Care Buttons

A Care Button Panel and Care Remote Buttons are available for use in disabled applications.

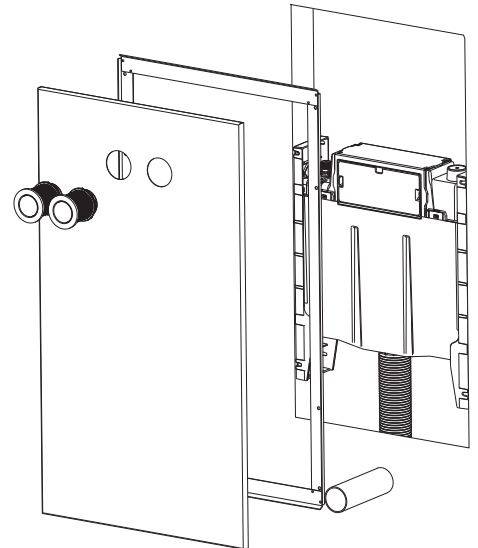

Large Button Panel

Used in combination with Round Remote Buttons or Care Remote Buttons allows access to the whole cistern .

Inwall Access - stud wall

- 1.** Check the DN 100 Soil Pipe is centred between the studs - check there is 400 - 420 mm between the studs (450mm nominal to stud centres).
- 2.** Calculate the finished floor height (allowing for floor gradings and tile thickness, etc.) and add this to the known height of the selected pan's inlet. Mark this resulting height on the stud - **This is your datum and flush pipe centre line.**
- 3.** Fix Nogging 25mm below datum.

- 4.** Cut flush pipe if required and chamfer the inside edge.
Note: "MAX" indicates the maximum amount that the flush pipe can be trimmed.

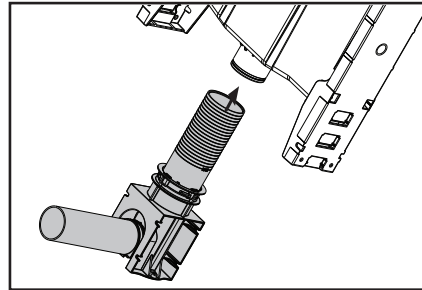

- 5.** Lubricate 'O'Ring on cistern tail using soapy water and slide flush pipe on.

- 6.** Screw cistern to studs via the 2 front, top and bottom holes in each mounting bracket making sure the water connection fitting is on the left hand side of cistern.

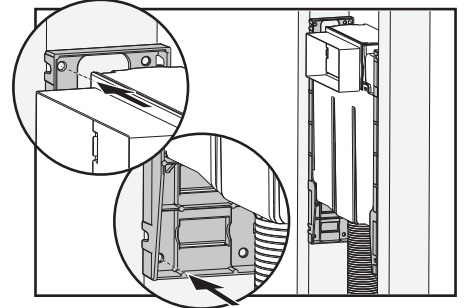

- 7.** Secure the flush pipe to the Nogging utilising 2 of the screw holes in the flush pipe mounting box and slide blue flush pipe tiling box over flush pipe.

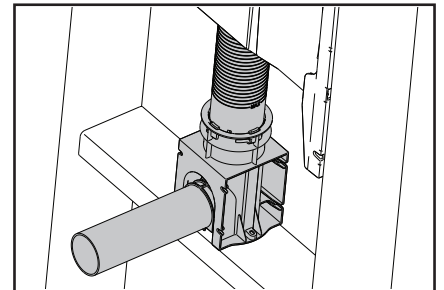

- 8.** Connect the water supply.

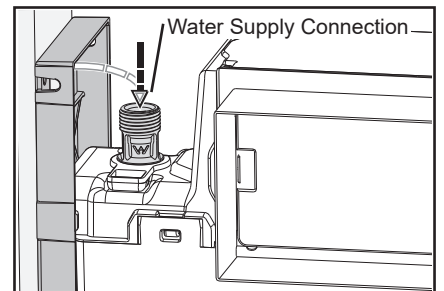

- 9.** Remove Dust Cover, turn Isolating Tap ON, fill tank & set water level using Adjusting Screw on the inlet valve.

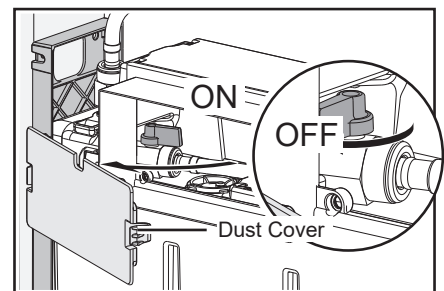

- 10.** Check cistern and all joints for leaks.

- 11.** Turn Isolating Tap OFF. Continue with Preparation for Fitout on page 20.

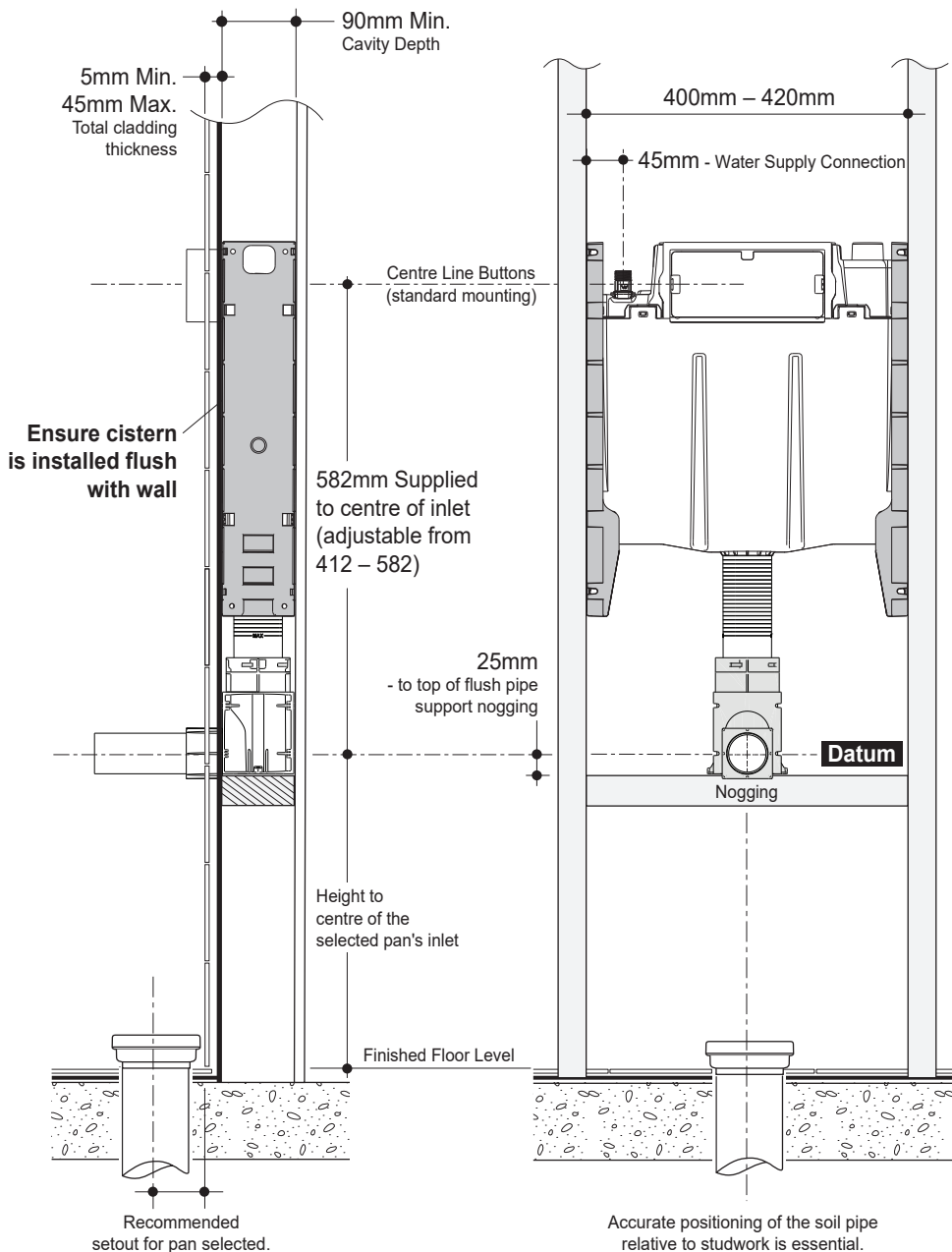

Inwall Access - masonry wall

1. Check the DN 100 Soil Pipe is centred to the hole built into the masonry wall.

2. Make sure the hole for the flush pipe is at the correct height. Calculate the finished floor height (allowing for floor gradings and tile thickness, etc.) and add this to the known height of the selected pan's inlet. Mark this resulting height on the wall - **This is your datum and flush pipe centre line.**

Confirm cistern location according to selected panel

3. Confirm size and positioning of opening as shown is relative to your datum. Allowance must be made for finishing of the wall above the flush pipe (refer to options on page 20.).

4. Cut flush pipe if required and chamfer the inside edge.

Note: "MAX" indicates the maximum amount that the flush pipe can be trimmed.

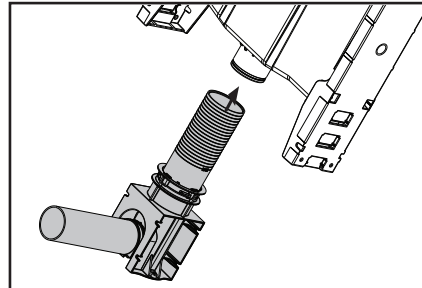

5. Lubricate 'O'Ring on cistern tail using soapy water and slide flush pipe on.

6. Screw cistern to wall via the 2 front, top and bottom holes in each mounting bracket making sure the water connection fitting is on the left hand side of cistern.

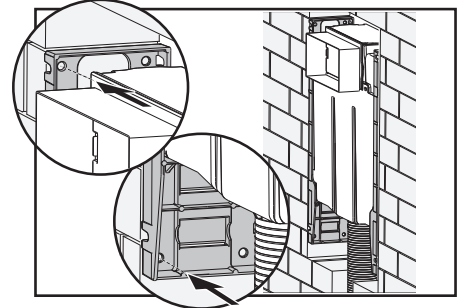

7. Secure the flush pipe to the masonry utilising 2 of the screw holes in the flush pipe mounting box and slide blue flush pipe tiling box over flush pipe.

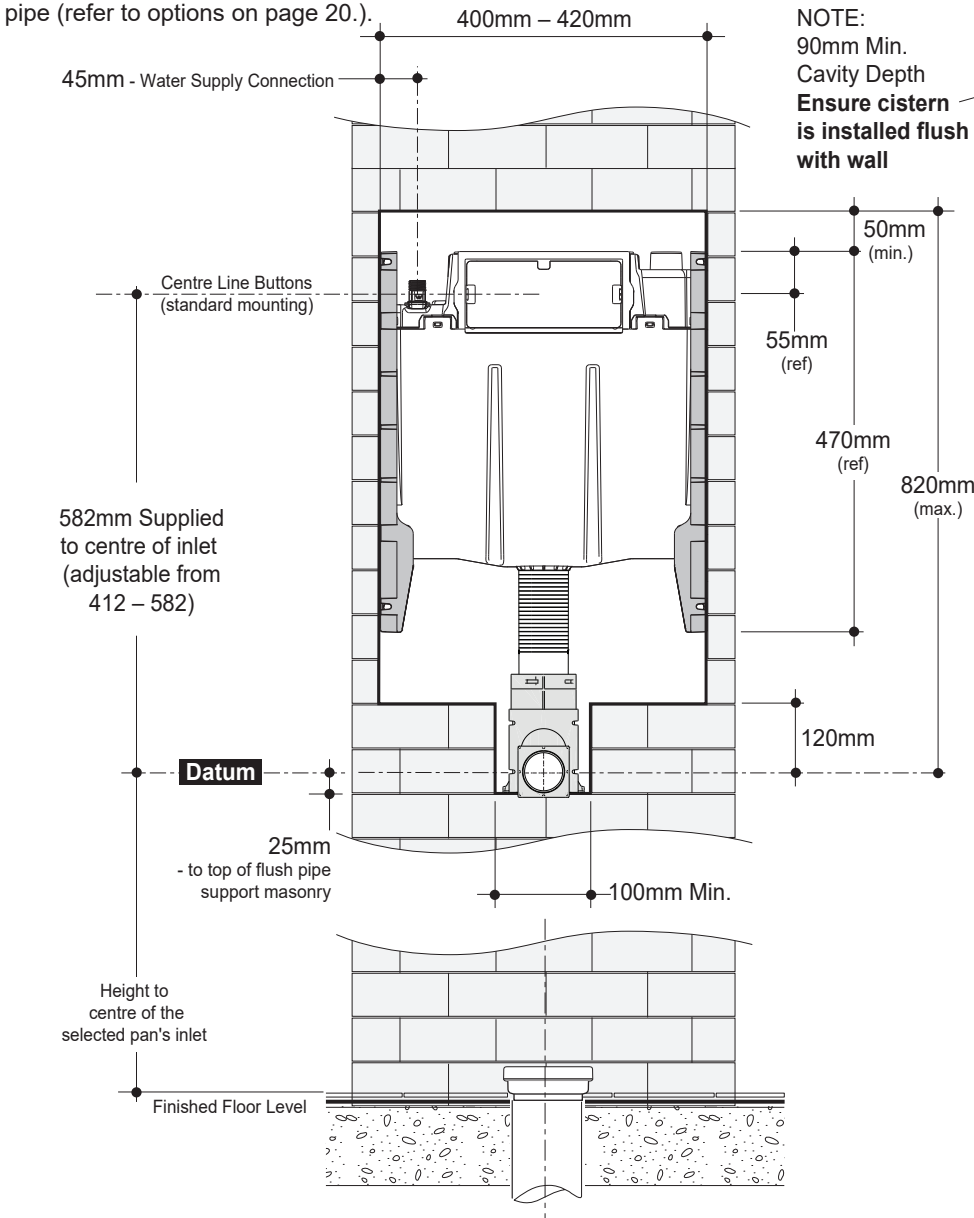
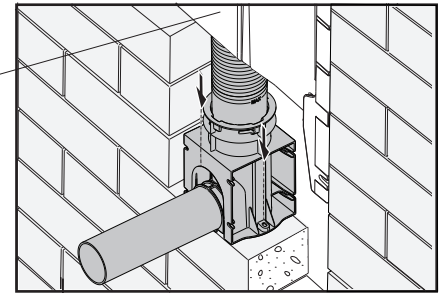

Accurate positioning of the soil pipe relative to studwork is essential.

8. Connect the water supply.

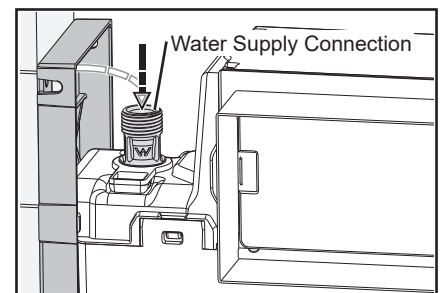

9. Remove Dust Cover, turn Isolating Tap ON, fill tank & set water level to the WL mark using Adjusting Screw on the inlet valve.

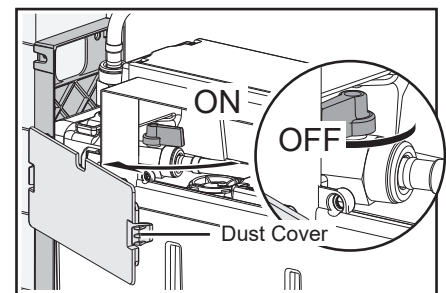

10. Check cistern and all joints for leaks.

11. Turn Isolating Tap OFF. Continue with Preparation for Fitout on page 20.

Induct Access

1. Calculate the finished floor height (allowing for floor gradings and tile thickness, etc.) and add this to the known height of the selected pan's inlet. Mark this resulting height on the wall - **This is your datum and flush pipe centre line.**
2. Drill a 51mm/2 inch minimum hole for the flush pipe, ensuring it is centred to your DN 100 Soil Pipe.
3. Fix a Nogging 25mm below datum.

4. Cut flush pipe if required and chamfer the inside edge.
Note: "MAX" indicates the maximum amount that the flush pipe can be trimmed.

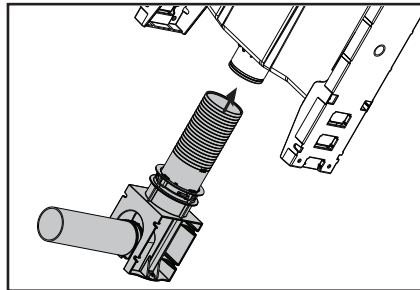

6. Place the flush pipe through hole and secure cistern to duct wall using 2 screws via holes provided in each of the mounting brackets.

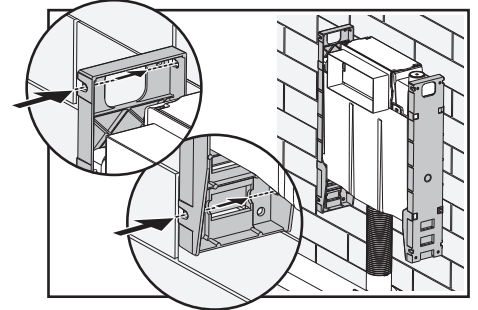

5. Lubricate 'O'Ring on cistern tail using soapy water and slide flush pipe on so that it is protruding in the opposite direction from that of the Service Access Box.

7. Secure the flush pipe to the Nogging utilising 2 of the screw holes in the flush pipe mounting box and slide blue flush pipe tiling box over flush pipe.

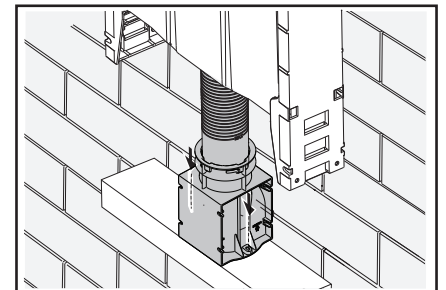

8. Connect the water supply.

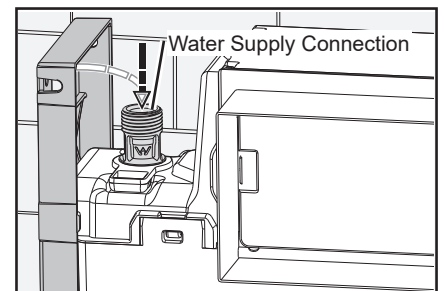

9. Remove Dust Cover, turn Isolating Tap ON, fill tank & set water level to the WL mark using Adjusting Screw on the inlet valve.

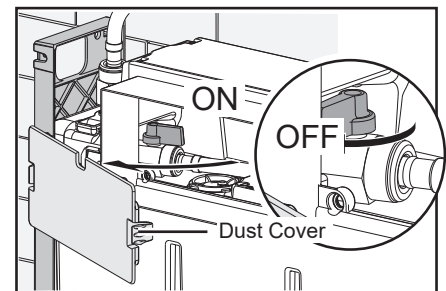

10. Check cistern and all joints for leaks.

11. Turn Isolating Tap OFF. Continue with Preparation for Fitout on page 20.

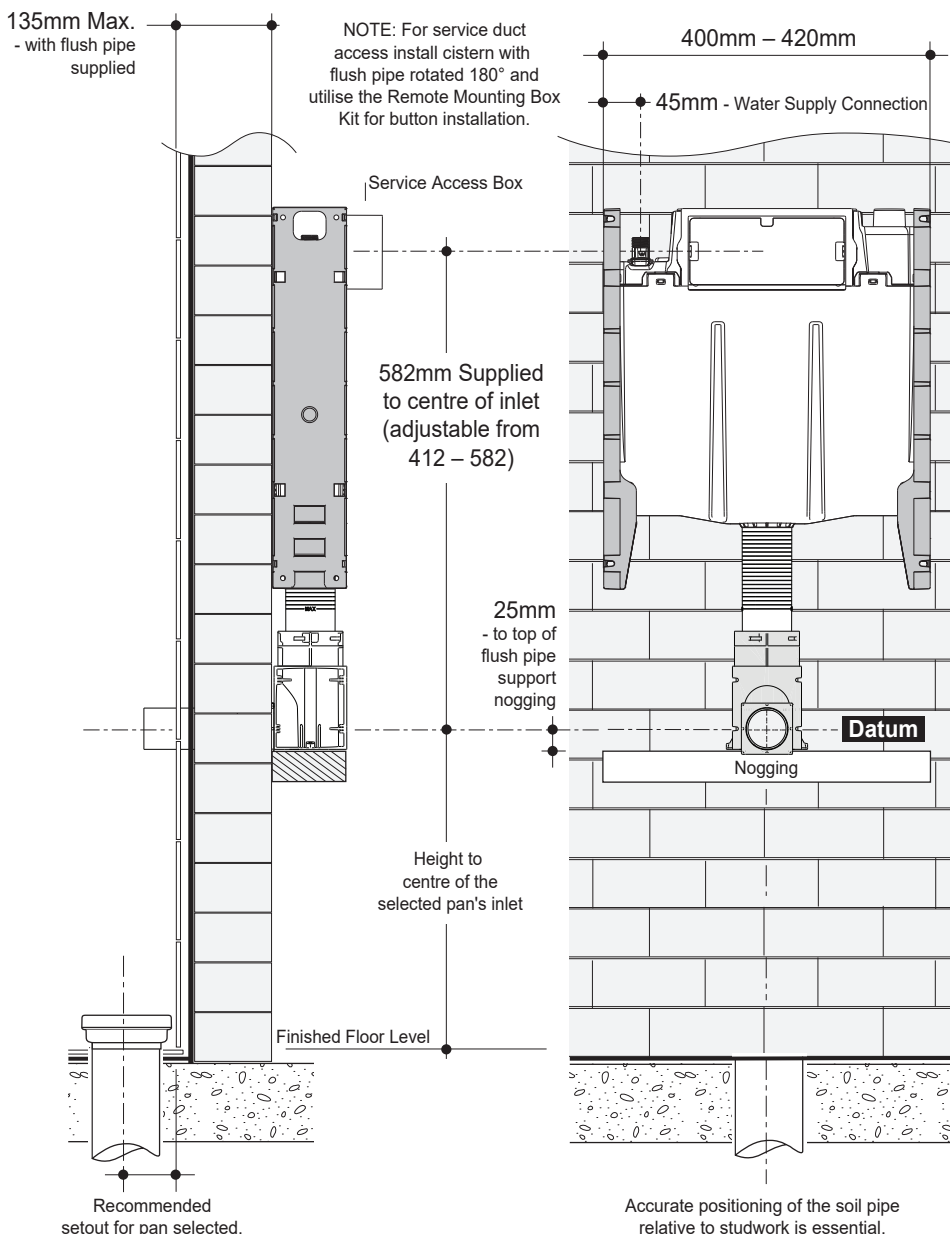

In Ceiling Access

1. Cistern can be a maximum height of 3 metres above the known height of the selected pan.
2. Calculate the finished floor height (allowing for floor gradings and tile thickness, etc.) and add this to the known height of the selected pan's inlet. Mark this resulting height on the stud - **This is your datum and flush pipe centre line.**

3. Fix Nogging 25mm below datum.

4. Utilising the Elevated Flush Pipe Parts included in the Remote Mounting Box Kit fabricate and install flush pipe (refer to page 18).
Note: "MAX" indicates the maximum amount that the flush pipe can be trimmed.

5. Lubricate 'O'Ring on cistern tail using soapy water and slide flush pipe on.

6. Screw cistern to studs via the 2 front, top and bottom holes in each mounting bracket making sure the water connection fitting is on the left hand side of cistern.

Note: Cistern may be installed on wall face (refer to page 8 - Induct Access)

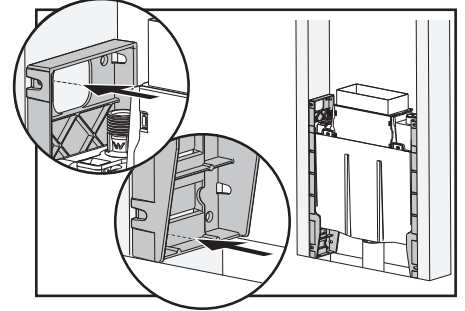

7. Secure the flush pipe to the Nogging utilising 2 of the screw holes in the flush pipe mounting box and slide blue flush pipe tiling box over flush pipe.

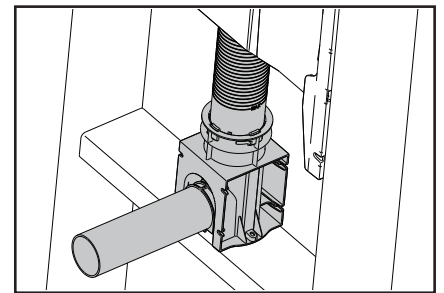

8. Connect the water supply.

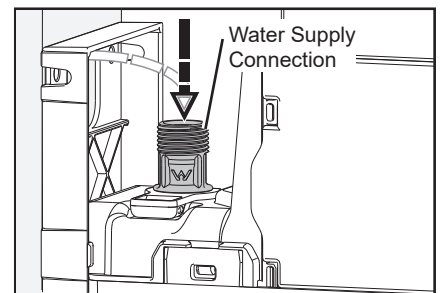

9. Remove Dust Cover, turn Isolating Tap ON, fill tank & set water level to the WL mark using Adjusting Screw on the inlet valve.

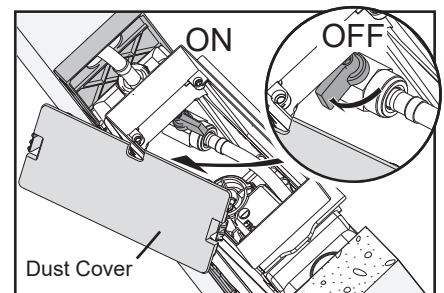

10. Check cistern and all joints for leaks.

11. Turn Isolating Tap OFF. Continue with Preparation for Fitout on page 20.

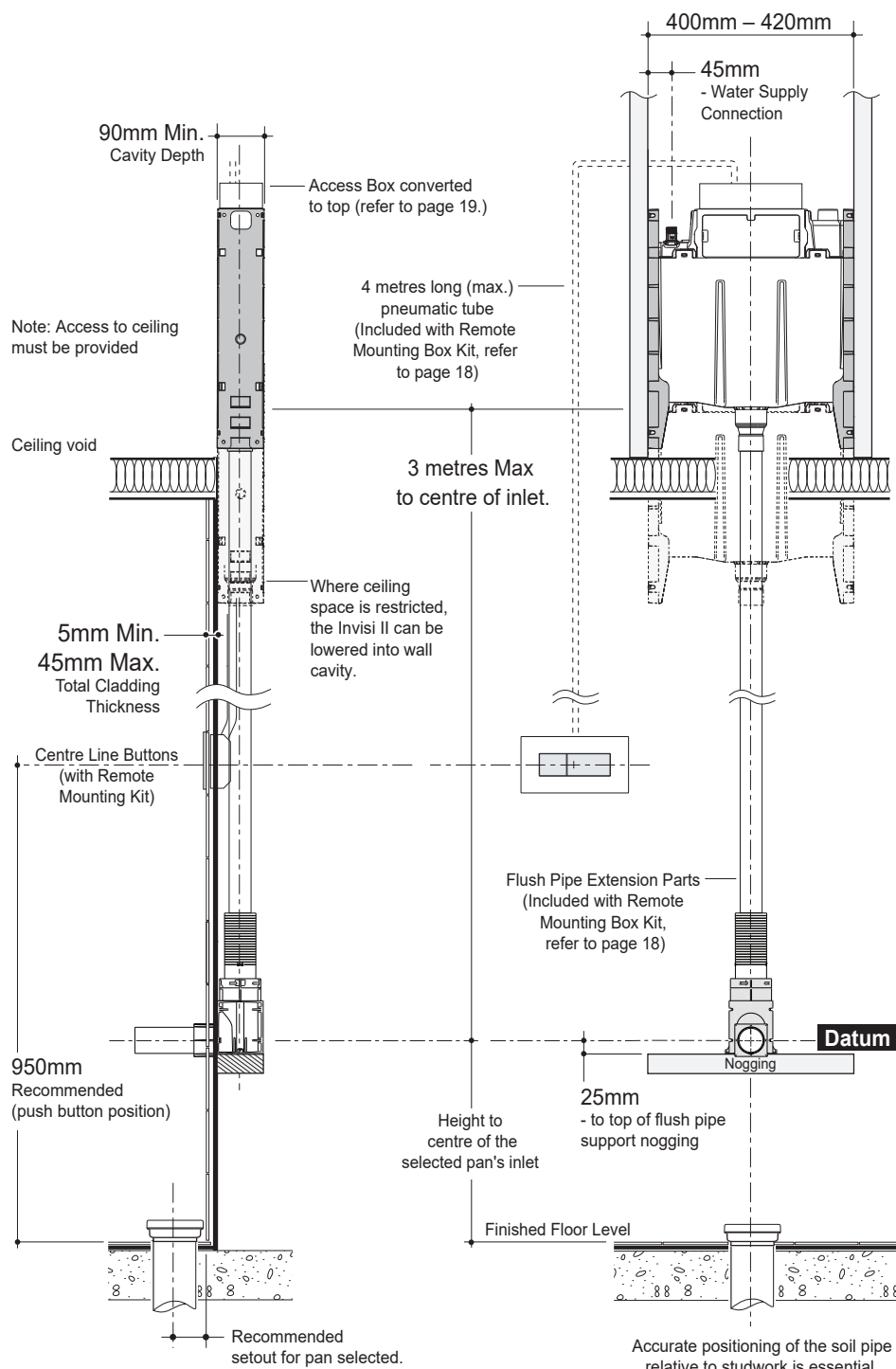

Under Counter Access (optional under counter flush pipe 237222 is required)

1. Check the DN 100 Soil Pipe is centred between the studs - check there is 400 - 420 mm between the studs (450mm nominal to stud centres).
2. Calculate the finished floor height (allowing for floor gradings and tile thickness, etc.) and add this to the known height of the selected pan's inlet. Mark this resulting height on the stud - **This is your datum and flush pipe centre line.**
3. Fix Nogging 25mm below datum.
Note: Where the Counter is at the minimum height the flush pipe must be trimmed to the "max" amount and cistern installed with the top surface of the Brackets hard up against the underside of the counter top.

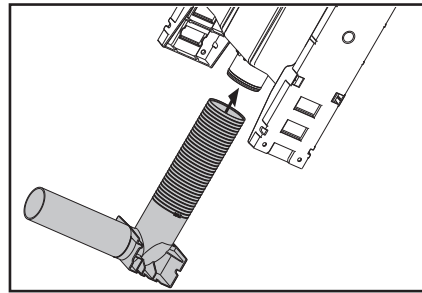

4. Cut flush pipe if required and chamfer the inside edge.
Note: "MAX" indicates the maximum amount that the flush pipe can be trimmed.

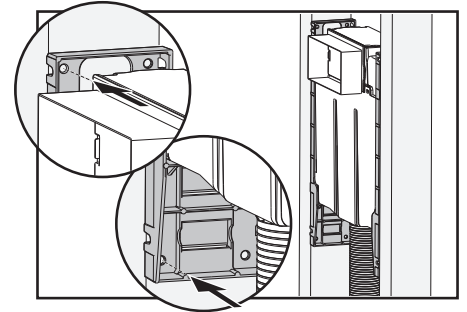

6. Screw cistern to studs via the 2 front, top and bottom holes in each mounting bracket making sure the water connection fitting is on the left hand side of cistern (continue next page).

5. Lubricate 'O'Ring on cistern tail using soapy water and slide flush pipe on.

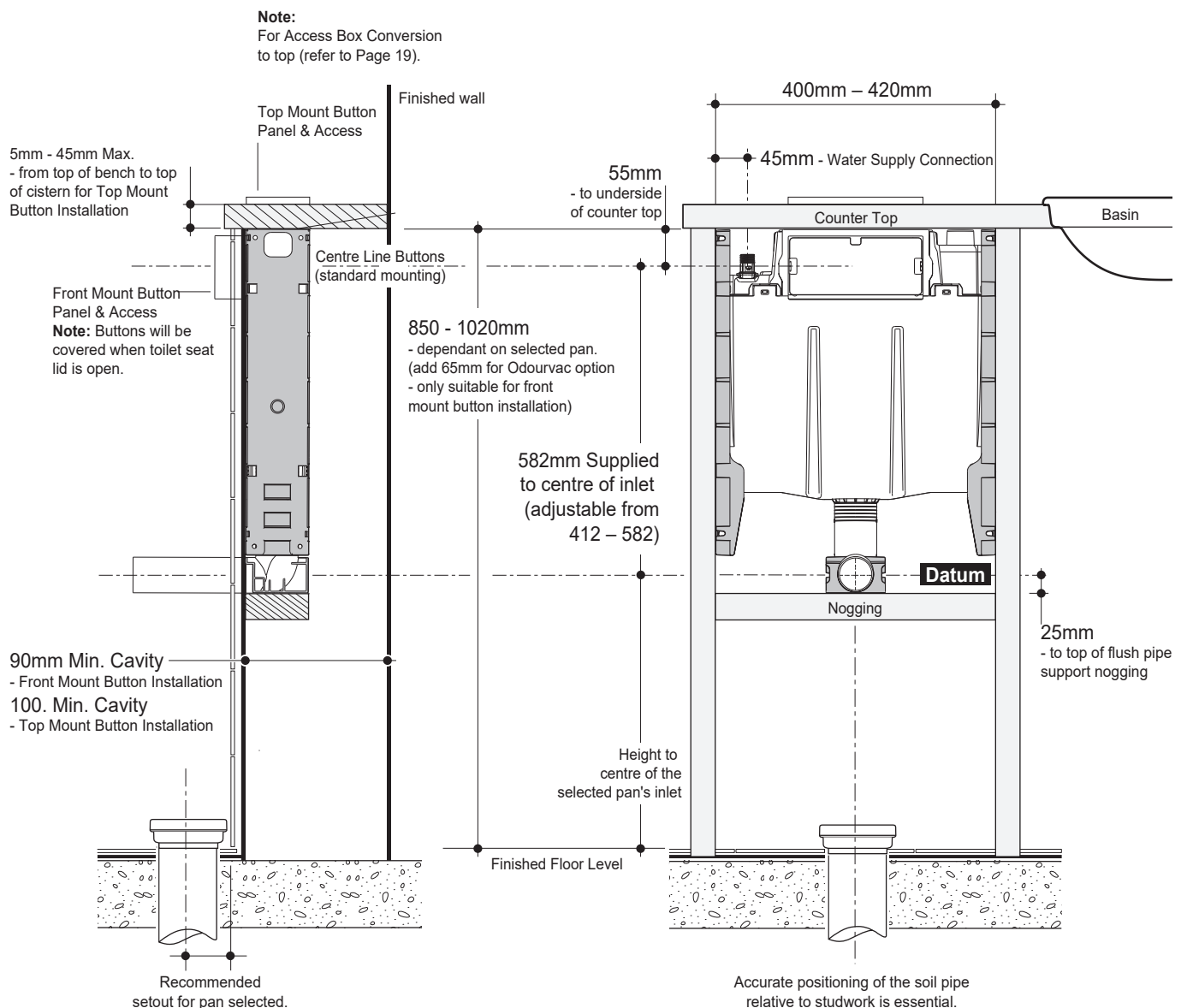

Under Counter Access - continued

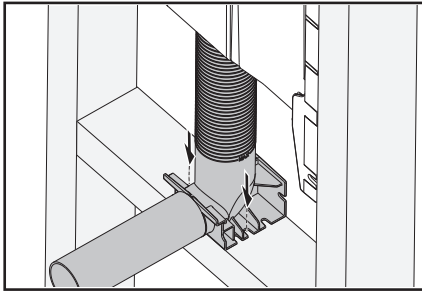

7. Secure the flush pipe to the Nogging utilising 2 of the screw holes in the flush pipe mounting box.

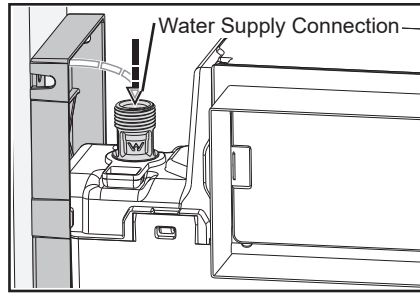

8. Connect the water supply.

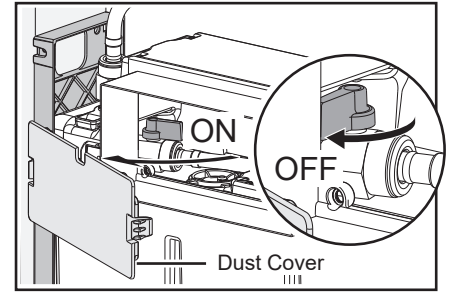

9. Remove Dust Cover, turn Isolating Tap ON, fill tank & set water level to the **WL** mark using Adjusting Screw on the inlet valve.

10. Check cistern and all joints for leaks.

11. Turn Isolating Tap **OFF**. Continue with Preparation for Fitout on page 20.

Custom Panel Access

1. The design of the custom panel is limited only by the designers imagination.

2. Cistern must be mounted using the attached Mounting Brackets. Refer to appropriate installation method on previous pages.

3. Allowances for access to at least the cistern internals if not the entire cistern must be incorporated into the design.

4. Refer to page 18 for flush pipe design guidelines.

The minimum front access requirements for servicing cistern internal are:

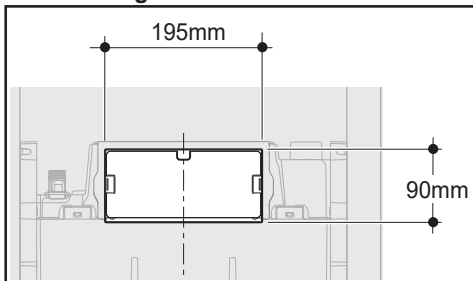

The minimum top access requirements for servicing cistern internal are:

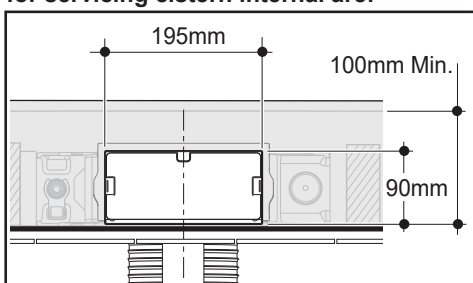

The minimum front access requirements for cistern removal are:

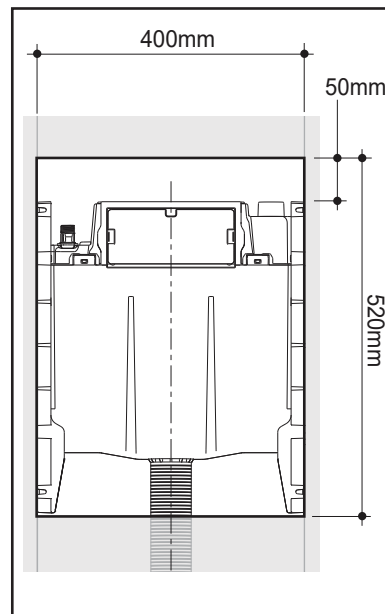

5. Check cistern and all joints for leaks..

6. Turn Isolating Tap **OFF**. Continue with Preparation for Fitout on page 20.

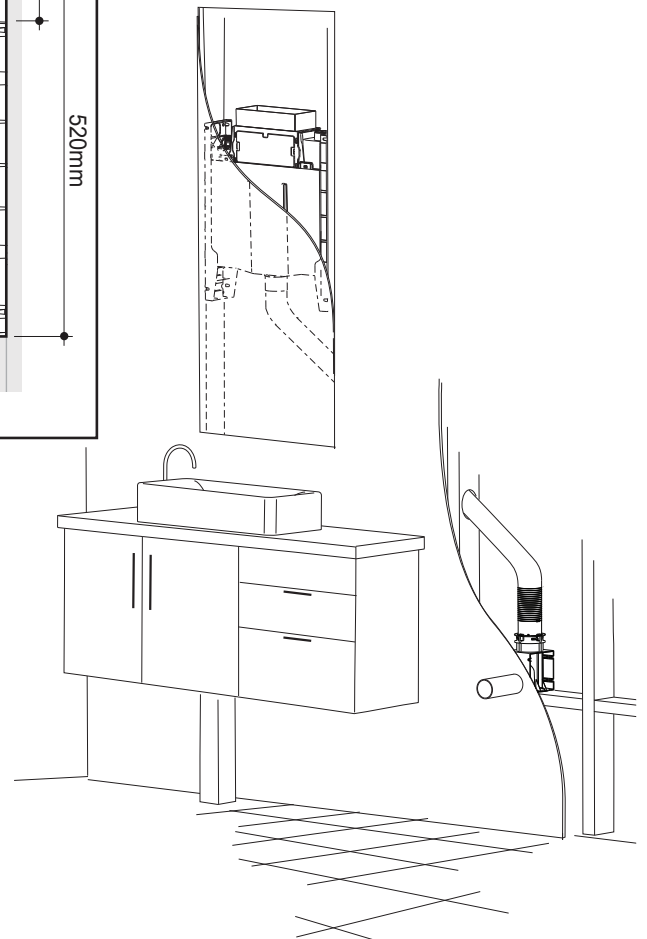

Inwall Access

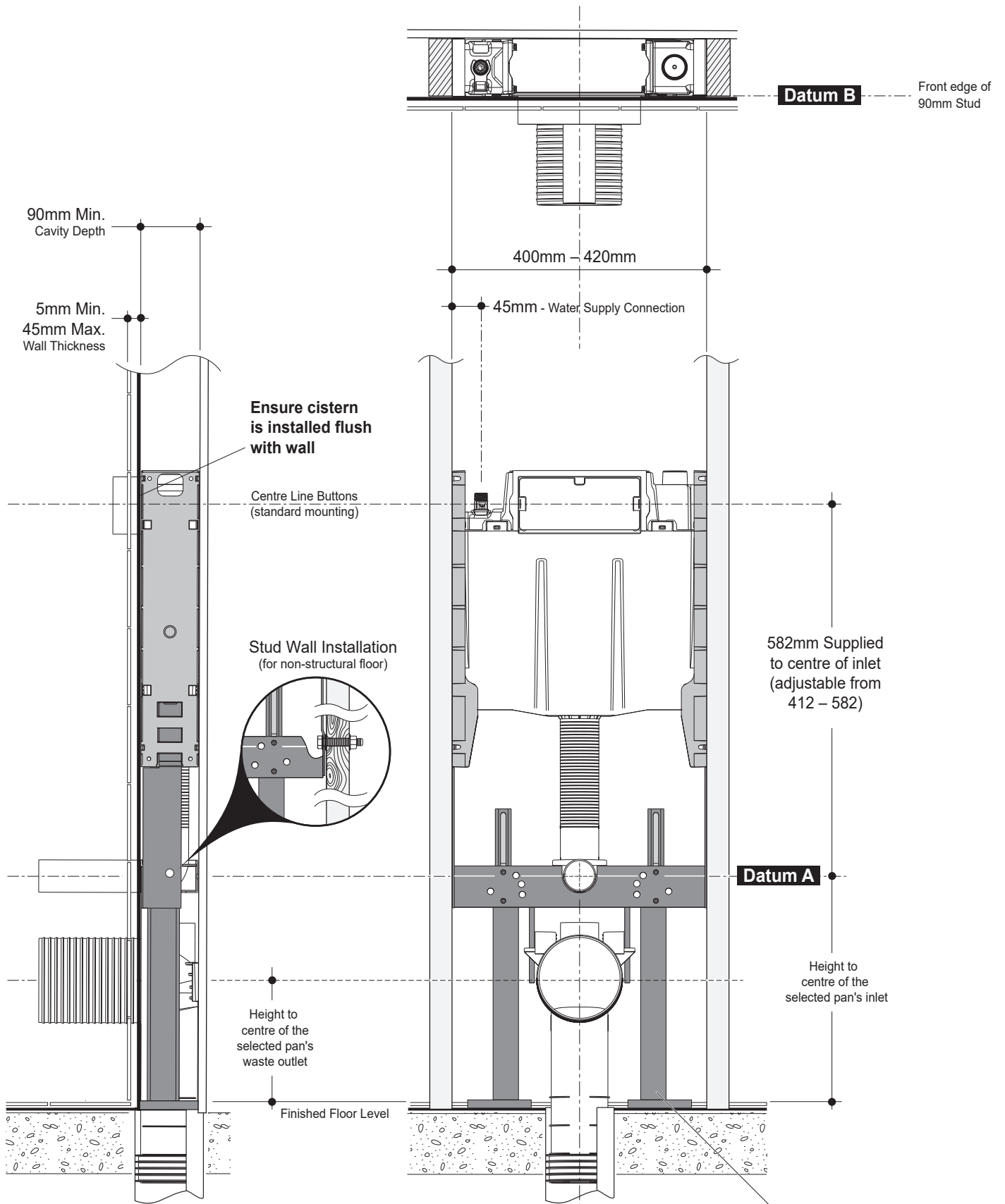

To achieve a minimum wall cavity of 90mm the soil pipe must be accurately centralised.

Accurate positioning of the soil pipe relative to studwork is essential.

Caroma Invisi 2 Integrated Wall Hung Pan Bracket

Inwall Access - continued

1. Check the DN 100 Soil Pipe is centred between the studs - check there is 400 - 420 mm between the studs (450mm nominal to stud centres).

2. Calculate the finished floor height (allowing for floor gradings and tile thickness, etc.) and add this to the known height of the selected pans inlet. Mark this resulting height on the stud - **This is your "Datum A" and flush pipe centre line.**

NOTE: When using a Large Panel, fabricating full size Custom Panel and or where adjustment of the cistern height in relation to "Datum A" is required refer to page 16.

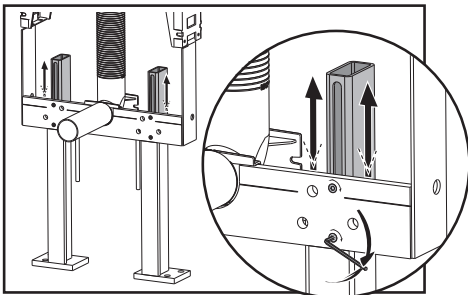

3. Measure and ensure the Flush Pipe Centre Line which is marked on the Pan Bracket is at the correct height. This should match the Datum A previously established. Use an allen key to adjust. Ensure bolts are tightened after setting.

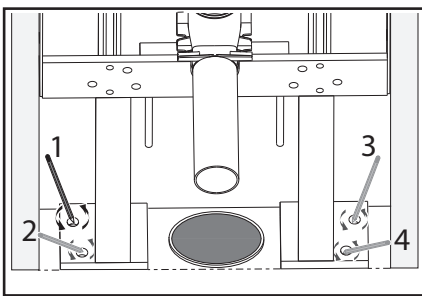

4. Place the Pan Bracket & Cistern Assembly in position and mark out all 4 bolt locations in the bracket feet.

NOTE: The front face of the Pan Bracket should be flush with the front face of the studs ("Datum B") & the DN 100 Soil Pipe should be central in both the wall cavity and between studs as well as being cut flush with the floor.

If using a Copper soil pipe, then use the part 237306 - Waste Pipe Seal - 100m Copper DWV (not supplied in this kit)

5. Move Pan Bracket & Cistern Assembly out of it's installation position and drill the 4 holes in the floor as marked.

For Structural Flooring

Drill Ø12mm hole for use with M12 TRU Bolts supplied in pack.

For Non Structural Flooring

Drill to suit fixings used (fixings not supplied). The vertical arms of the pan bracket must also be bolted to side studs.

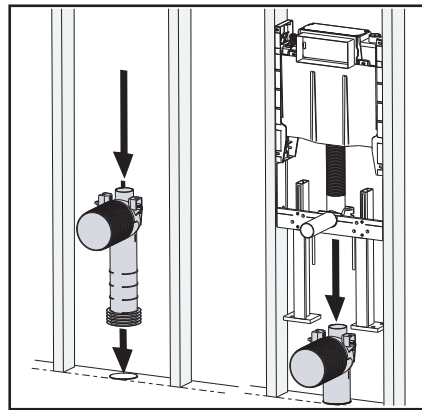

6. Lubricate the Waste Pipe with soap and water and push into the soil pipe. Carefully reposition Pan Bracket & Cistern Assembly and secure with fixings.

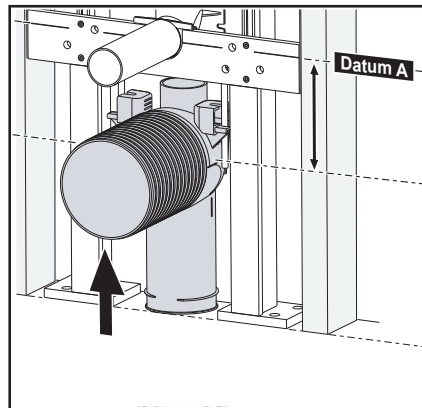

7. Slide the Waste Pipe up so the centre line marked on the body is set at the correct spacing from the flush pipe "Datum A".

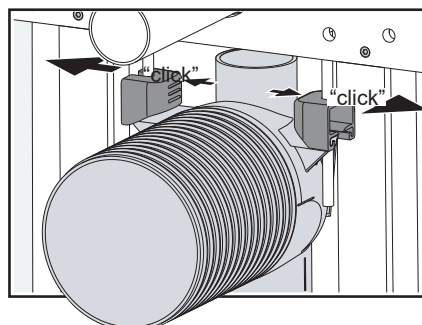

8. Secure the Waste Pipe position by firmly pushing the Waste Pipe Clips outwards to latch on to the threaded rods.

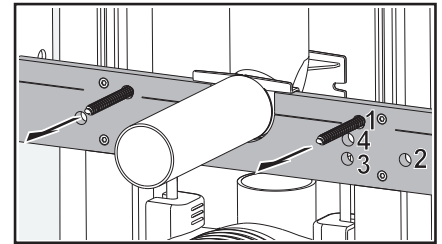

9. Screw in threaded rods for mounting the pan and lock in position with nuts against the Front Plate. Four hole spacings are accommodated to suit the selected pan:

- 1 - 200mm
- 2 - 280mm
- 3 - 180mm
- 4 - 180mm

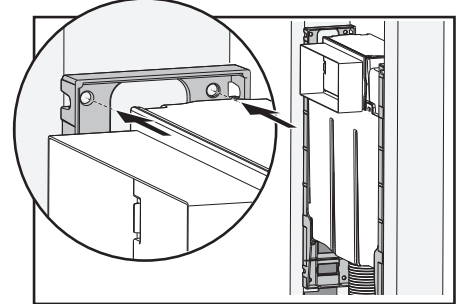

10. Screw the cistern in place using at least 1 of the 2 holes provided in the top of each mounting bracket. Make sure the water connection fitting is on the left hand side of cistern and cistern is flush with wall.

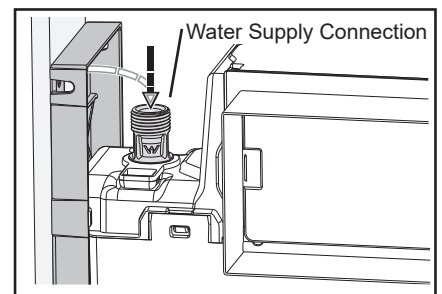

11. Connect the water supply.

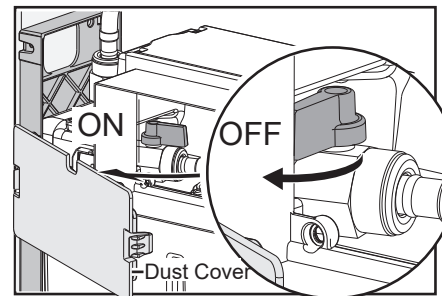

12. Remove Dust Cover, turn Isolating Tap ON, fill tank & set water level to the WL mark using Adjusting Screw on the inlet valve.

13. Check cistern and all joints for leaks.

14. Turn Isolating Tap OFF. Continue with Preparation for Fitout on page 20. 13

Induct Access

Refer to pages 12 to 13 for installation procedure.

NOTE: For Induct Structural Wall installations the Invisi 2 cistern pack 237 007 in conjunction with the D788 Sanifix Bolt Through Wall Pan Bracket (Code No. 687 788) is recommended, as pictured adjacent.

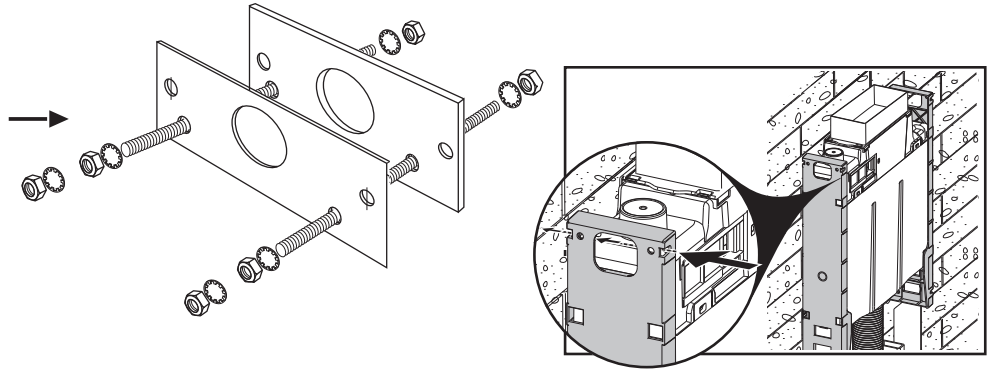

135mm Max. with supplied flush pipe.
Ensure at least 300mm clearance above top of cistern for service access.

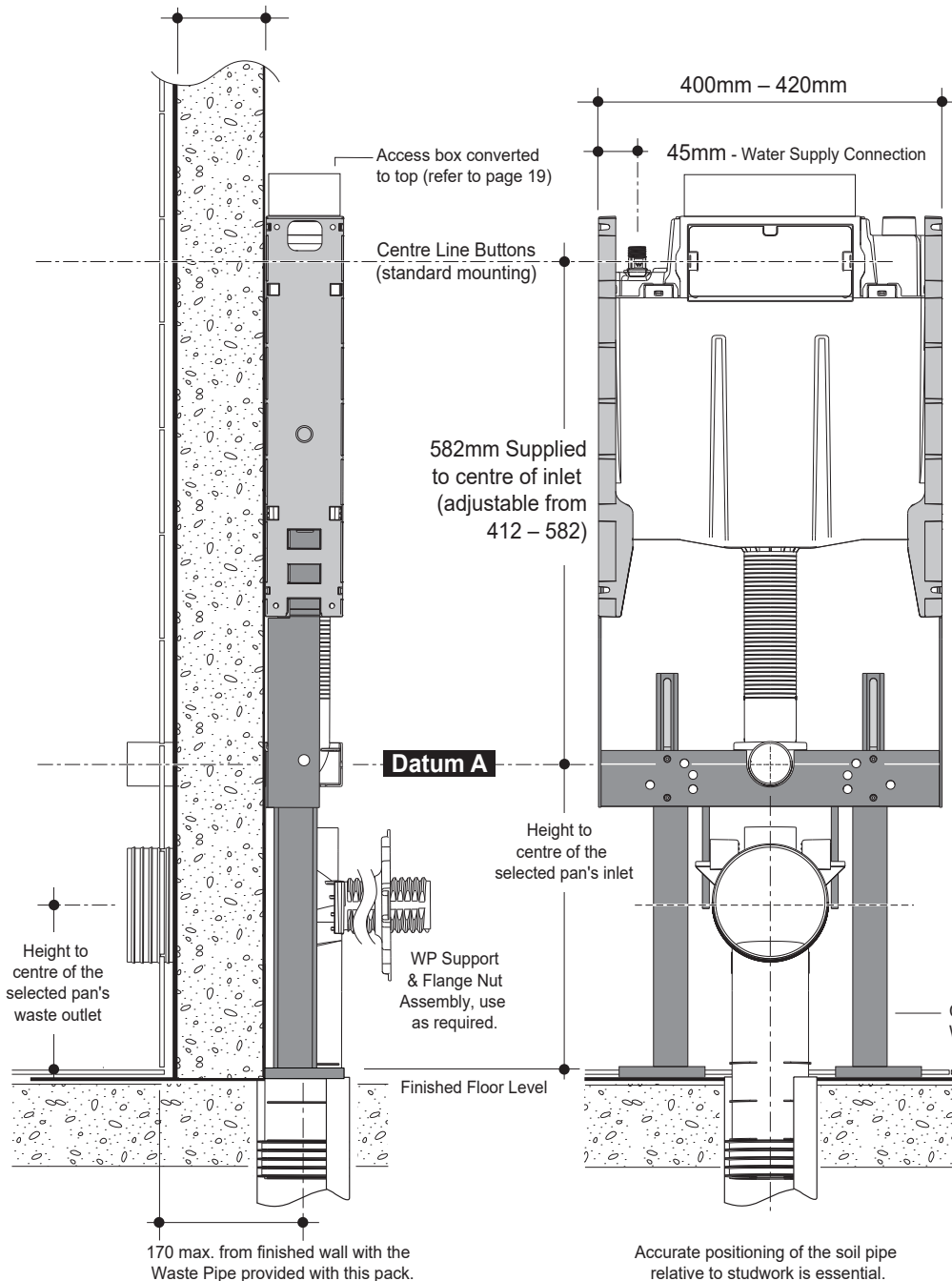

Waste Pipe Adjustment

Allows for the DN 100 Soil Pipe being set back from the wall face up to 25mm.

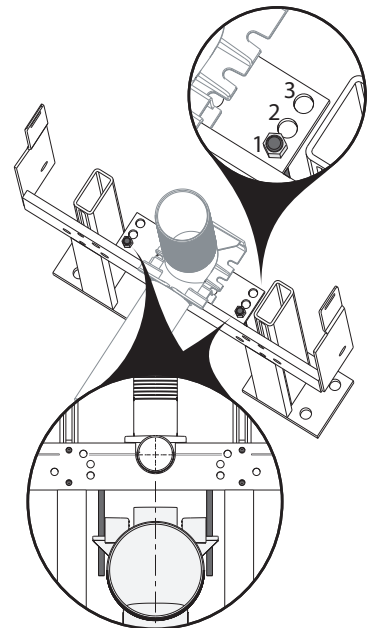

Accurate positioning of the soil pipe relative to studwork is essential.

In Ceiling Access

Refer to page 16 for removing the cistern from the pan bracket, before referring to pages 12 to 13 for installation procedure.

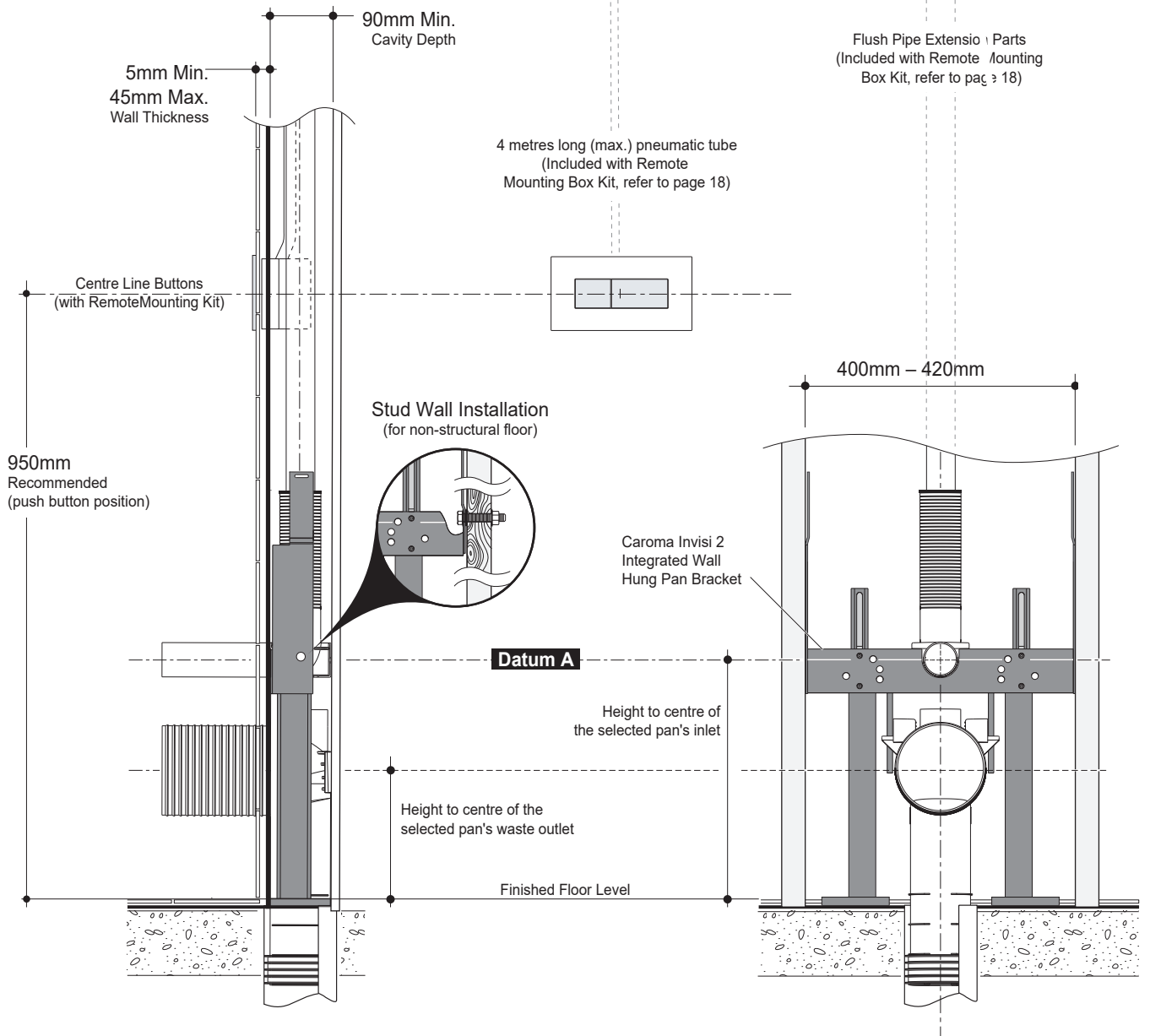
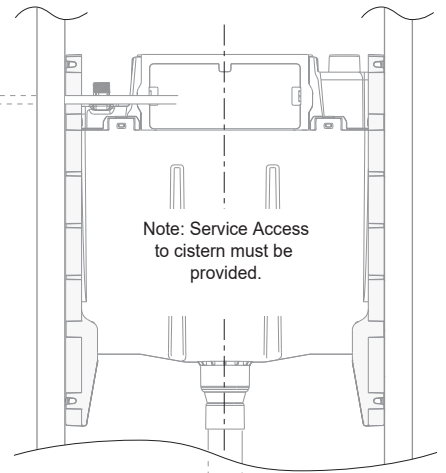

To achieve a minimum wall cavity of 90mm the soil pipe must be accurately centralised.

Accurate positioning of the soil pipe relative to studwork is essential.

Where removal of the cistern may be required.

- When using a Large Panel or full size custom panel.

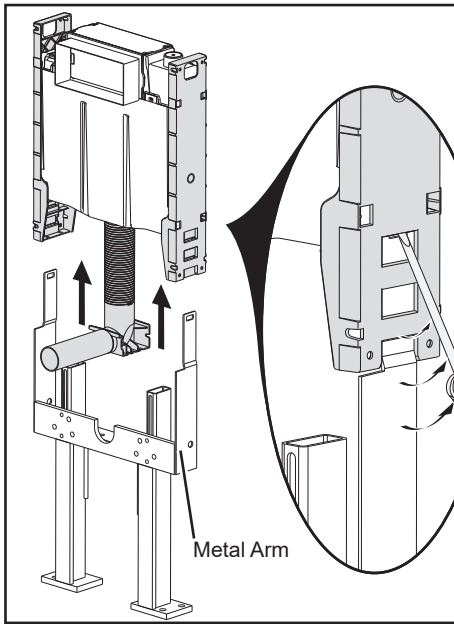

Remove cistern from Pan Bracket using a screw driver to lever the plastic tab out of the hole in the Metal Arm, both sides.

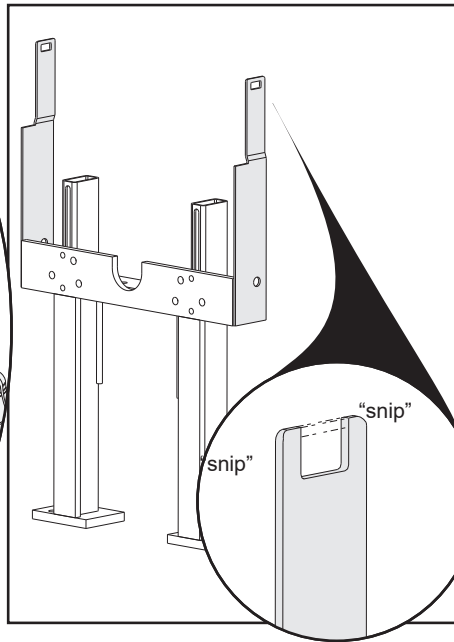

Cut the hole in the metal arm so it is open at the top. This ensures the plastic tab will no longer lock in position.

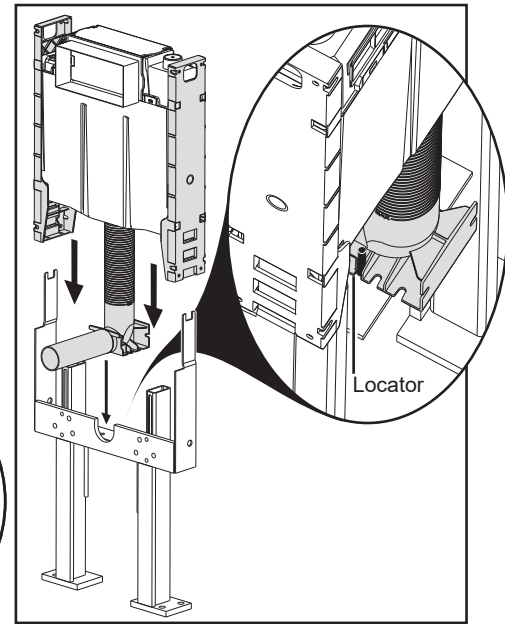

Slide the cistern back into place ensuring the Flush Pipe is correctly positioned on the Pan Bracket.

Continue with installation (Refer to pages 12 to 13 for procedure).

Where adjustment of the cistern height is required.

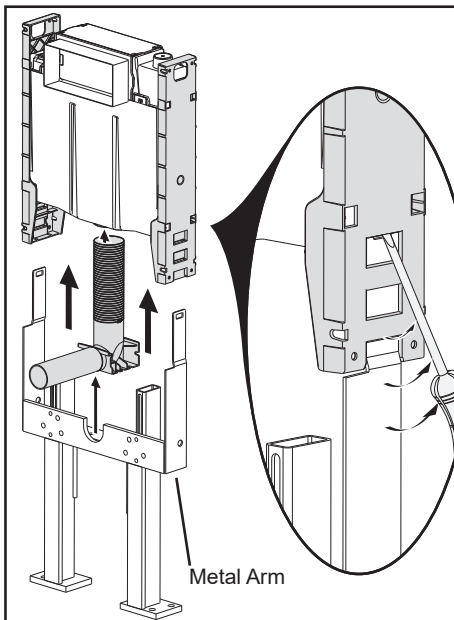

Remove cistern from Pan Bracket using a screw driver to lever the plastic tab out of the hole in the Metal Arm, both sides.

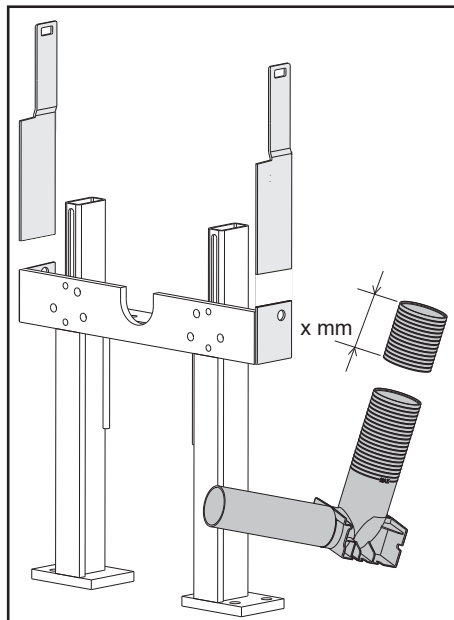

If the Height of the cistern is to be lowered, cut the Flush Pipe and chamfer the inside edge.

Remove the Metal Arms of the Pan Bracket at the point shown. **Note:** Lowering the cistern may cause buttons to be covered when toilet seat lid is open.

If the cistern height is to be raised then Flush Pipe Extension Parts included in the Remote Mounting Box Kit (refer to page 18) are required.

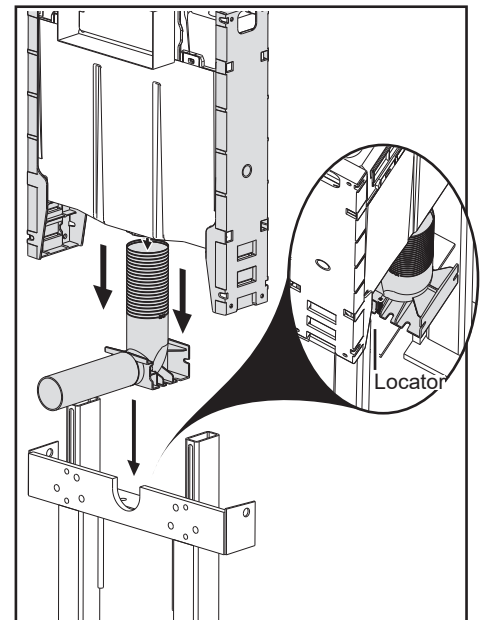

Lubricate 'O' Ring on cistern tail using soapy water & slide Flush Pipe on.

Ensure the Flush Pipe is correctly positioned on the Pan Bracket.

Continue with installation (Refer to pages 12 to 13 for procedure).

Under Counter Access

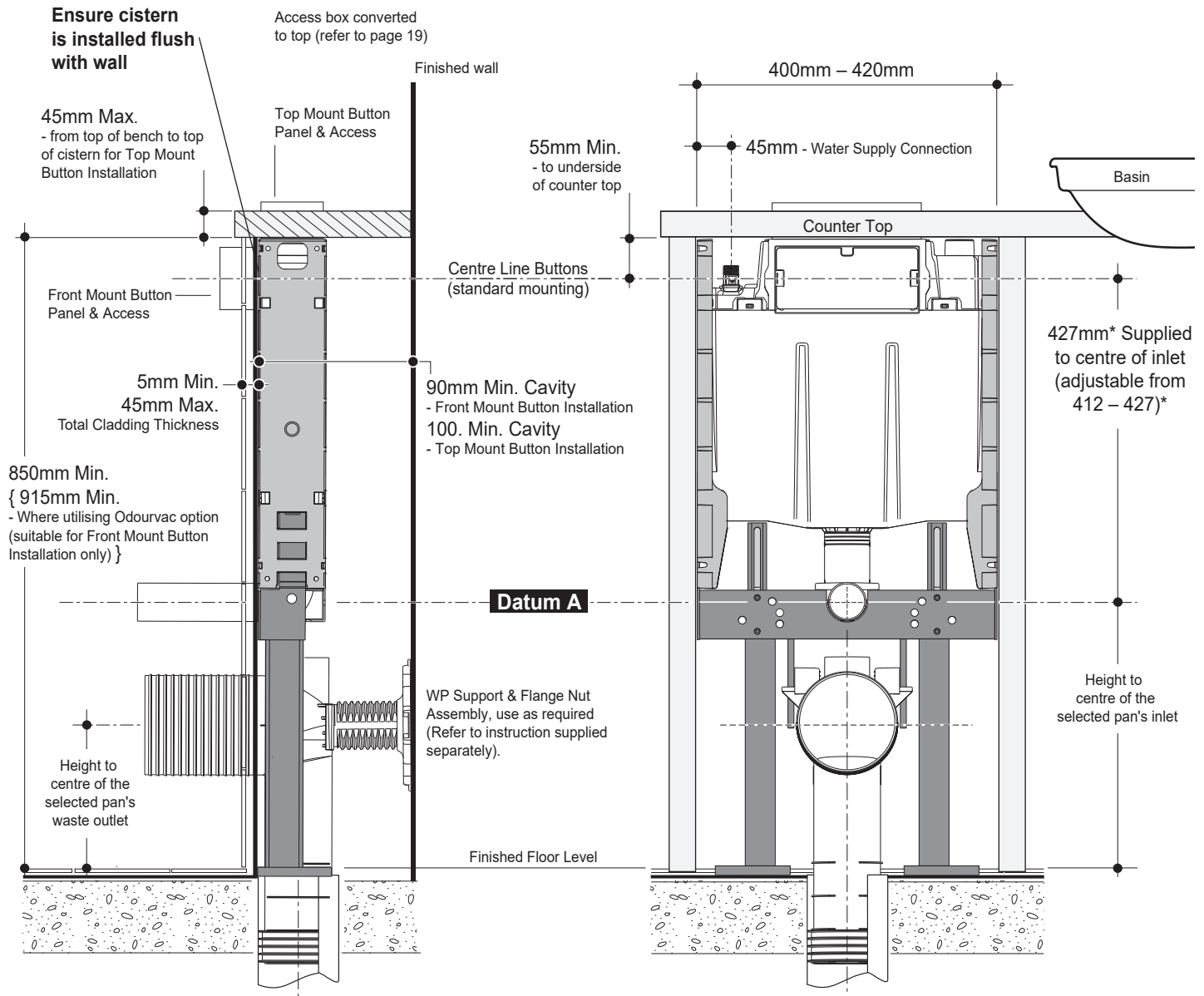

Accurate positioning of the soil pipe relative to studwork is essential.

To achieve a minimum under counter cavity of 90mm the soil pipe must be accurately centralised.

The Bracket system is suitable for installation only where non compressible wall materials are used.

Note: For undercounter front access, the buttons will be covered when the toilet seat lid is open

Kit Includes

- Remote Mounting Box
- 2 x 4m Pneumatic Tubes
- Breather Tube
- Cistern Adaptor
- Flush Pipe Adaptor

The Remote Mounting Box has been specifically designed in conjunction with and to facilitate the installation of button panel sets in remote Invisi II installations.

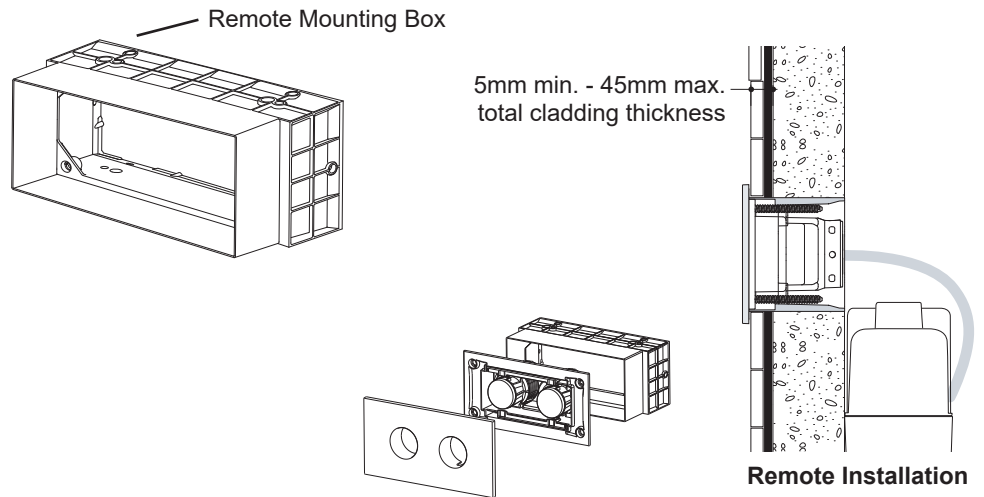

Example - Inceiling/Remote Installation

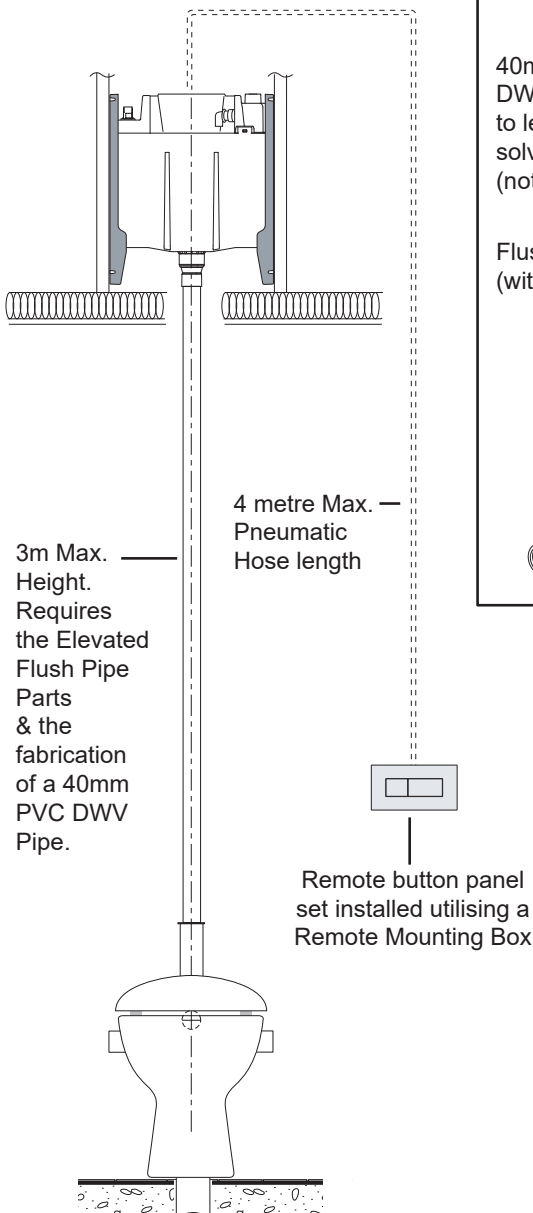

Elevated Flush Pipe Parts

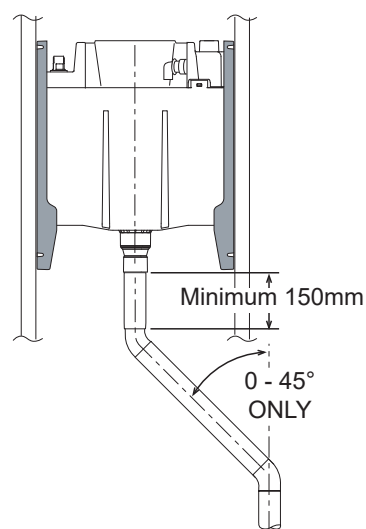
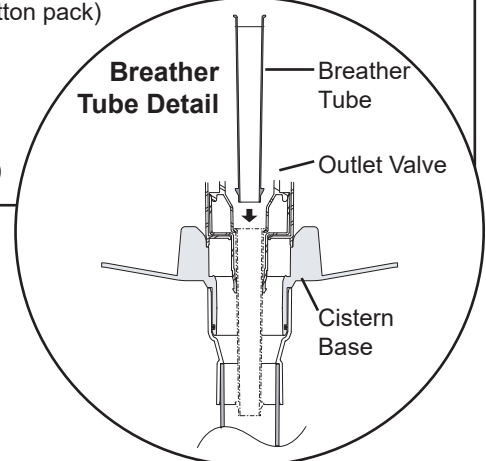
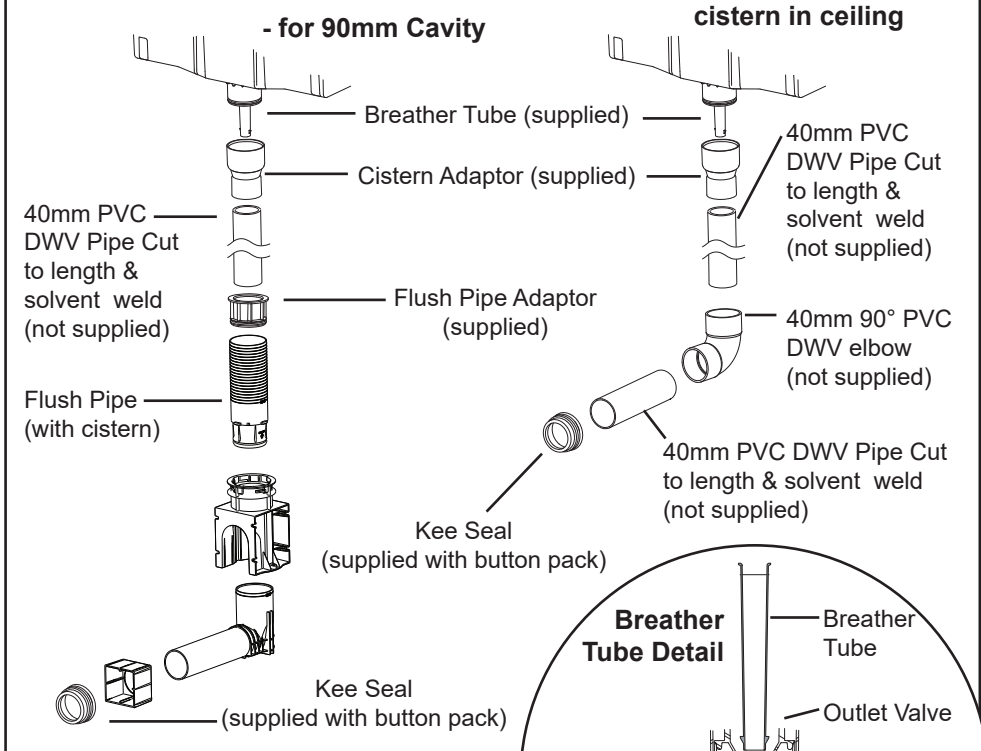

Example - Offset/Remote Installation

NOTE:
All flush pipe offsets must be run at 45°. The inclusion of any additional bends in the flush pipe may have a negative effect on the products flushing performance.

The Cistern is supplied standard with Front Access.
For conversion from Front to Top Access follow this procedure.

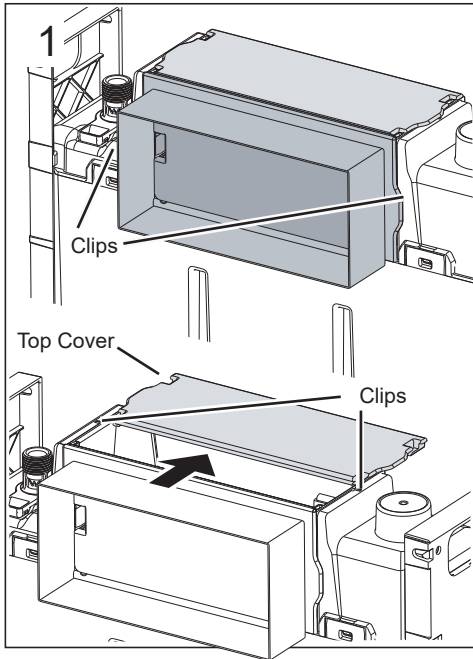

Slide the Top Panel back and off the lid. (This panel will no longer be required). There are clips at each end so the Top Panel should be carefully levered or flexed to clear both clips.

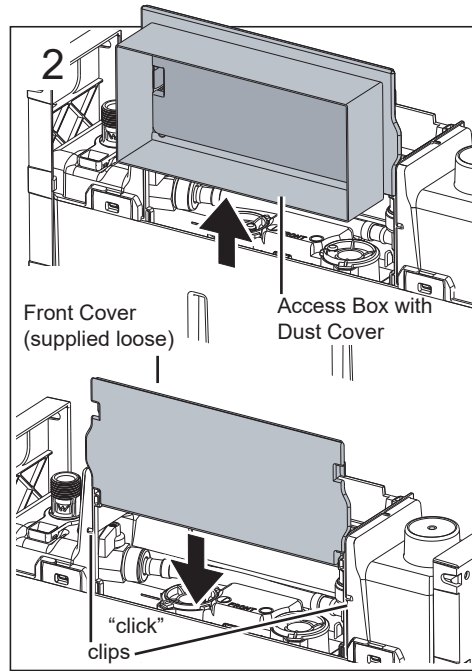

Slide the Access Box up and off the lid. There are clips at each end so the Top Panel should be carefully levered or flexed to clear both clips.

Find the Front Panel supplied loose in the pack (This panel is slightly larger than the Top Panel). Slide the Front Panel onto the lid ensuring it locks into position.

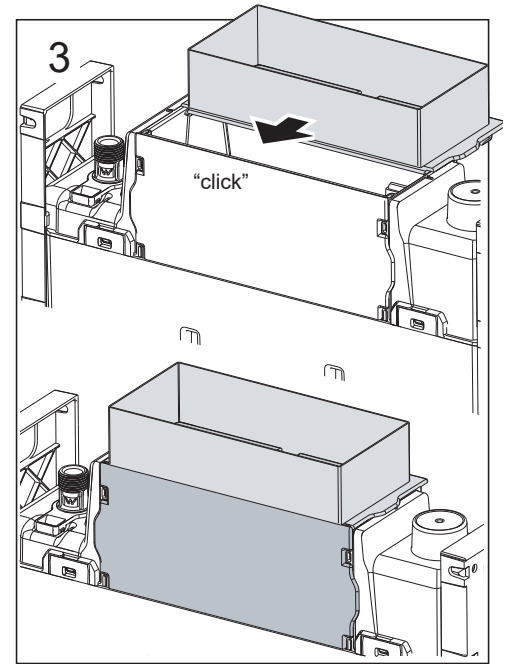

Slide the Access Box onto the lid ensuring the overhang tab is to the rear of the cistern and it locks into position.

The Panel and Access Box should lock together neatly as shown.

6/3 Litre Conversion

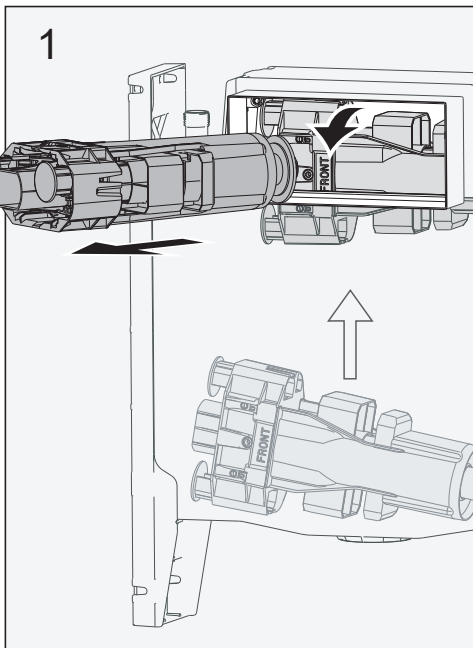

Ensure mains water is turned off and remove Outlet Valve from cistern as per the instructions page 21.

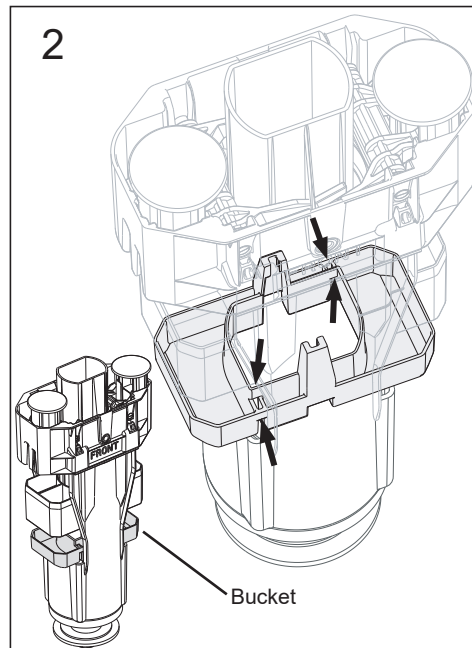

Using side cutters or a knife cut the Bucket in all 4 places.

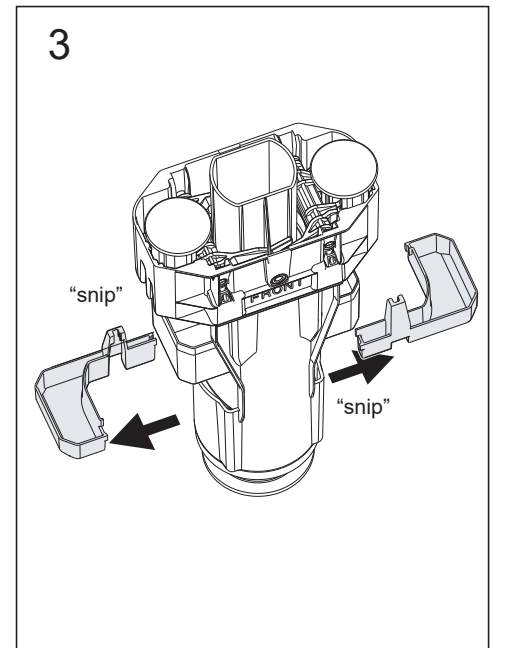

Remove and discard Bucket. Refit Outlet Valve and all other internals back into the cistern.

Pneumatic Tube Connections

Firmly connect the pneumatic tube into the half and full flush positions. Each tube should be inserted approx. 16mm until it hits a stop.

NOTE:

- 4.5/3L Cisterns are supplied with 0.5m length pneumatic tube.
- Remote Mounting Box Kit is supplied with 2 x 4m lengths of pneumatic tube.
- 4m lengths of pneumatic tube can be purchased separately Part No. 237 702

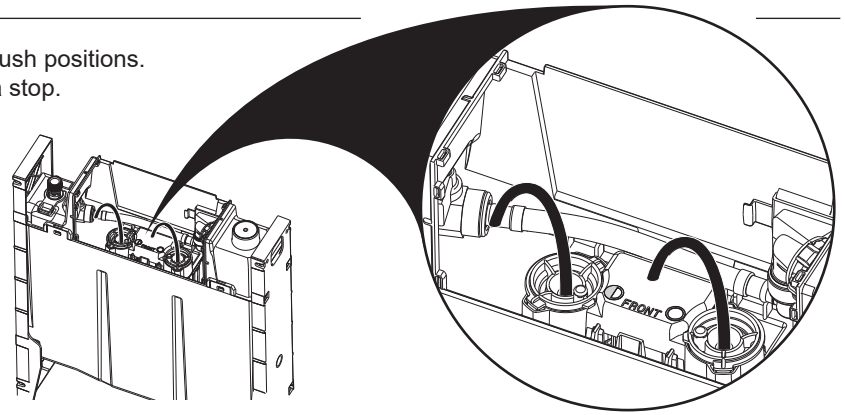

Direct Panel Mounting

Cut Pneumatic Tube in half so you have 2 x 0.25m lengths. Attach the tubes to the cistern as shown above. Tuck neatly back inside the Access Window and clip the dust cover panel back into position. When finishing the wall, clad and tile right up to the edge of the Access Window.

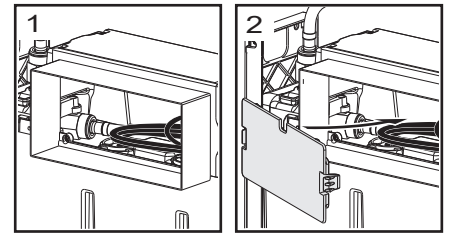

Remote Panel Mounting

Attach the tubes to the cistern as shown above. Break out tab in the Top Panel or Dust Cover Panel to allow the Tubes to protrude and clip back into position. Feed the 4m lengths of Pneumatic Tube through the framework and out through the Mounting Box. Apply tape over end of tubes to prevent any dirt from getting inside and tuck neatly back inside the Mounting Box. When finishing the wall clad and tile right up to the edge of the Access Window and or Remote Mounting Box.

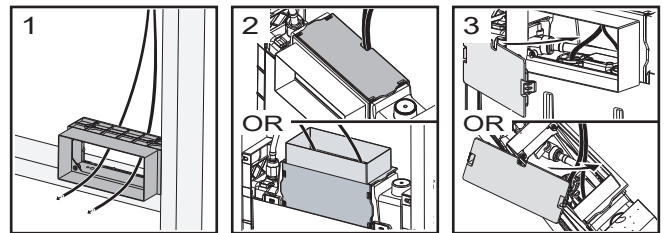

Remote Button Mounting

Attach the tubes to the cistern as shown above. Break out tab in the Top Panel or Dust Cover Panel to allow the Tubes to protrude and clip back into position. Feed Pneumatic Tubes through the framework and out through the Drilled Holes. Apply tape over end of tubes to prevent any dirt from getting inside and tuck neatly back inside holes.

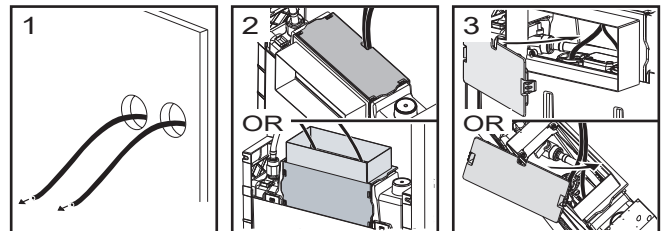

Large Button Panel

Attach the tubes to the cistern as shown above. Break out tab in the Top Panel to allow the Tubes to protrude and clip the Dust Cover Panel back into position. Trim the Access Window all around so it protrudes between 10-15mm from the front face of the Dust Cover Panel. Apply tape over end of tubes to prevent any dirt from getting inside and tuck neatly back inside the large Access Window.

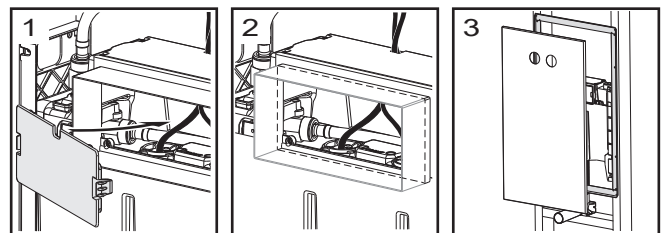

Options for Finishing Around the Flush Pipe

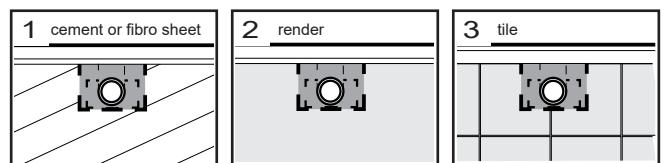

Pan Bracket

Ensure the Wall Hung Pan Mounting Bolts, Flush Pipe and Waste Pipe are all set to the correct height and spacing to suite the selected pan. When finishing the wall clad and tile right up to the edge of these parts.

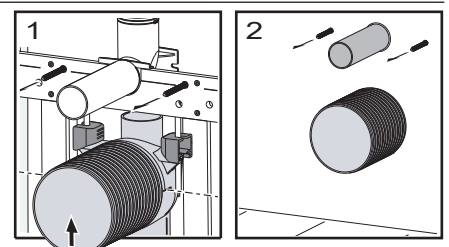

Removing Internal Components through Access Window

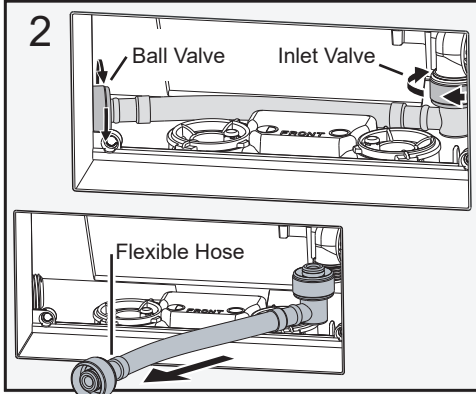
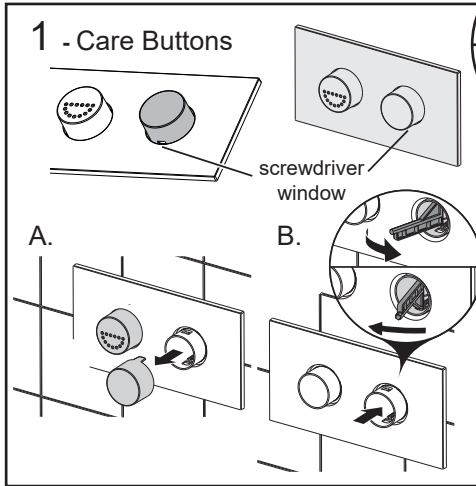
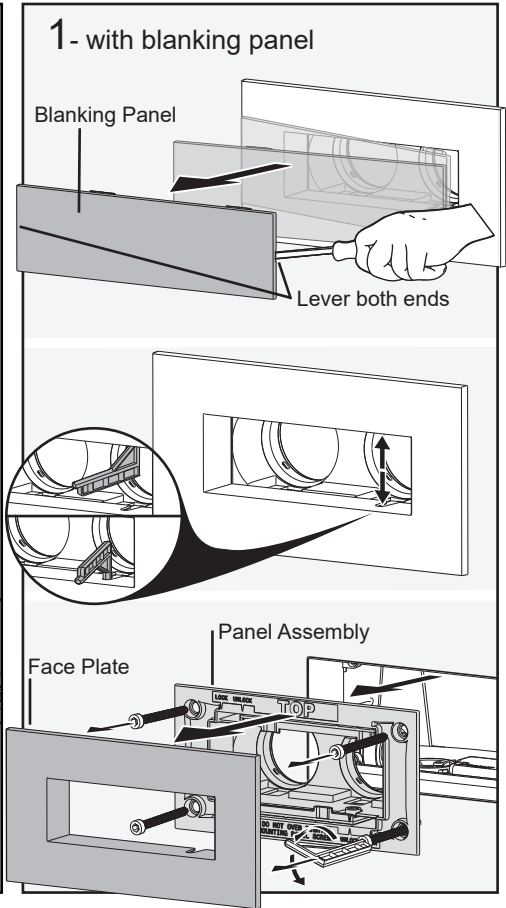
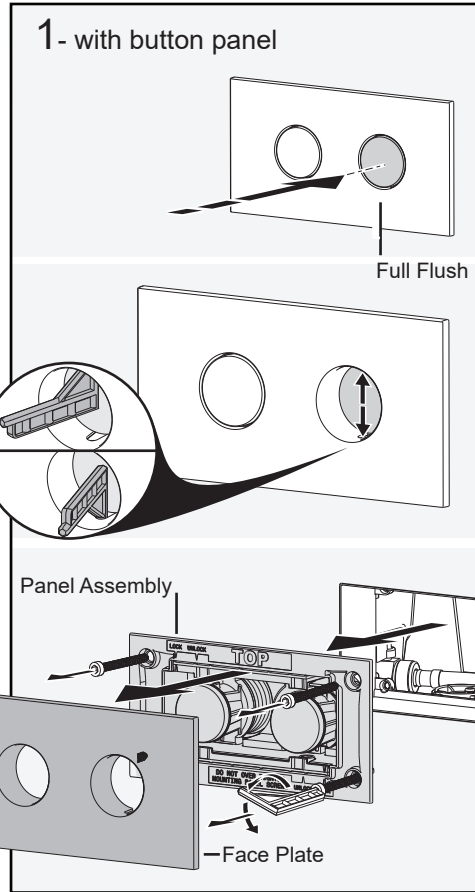
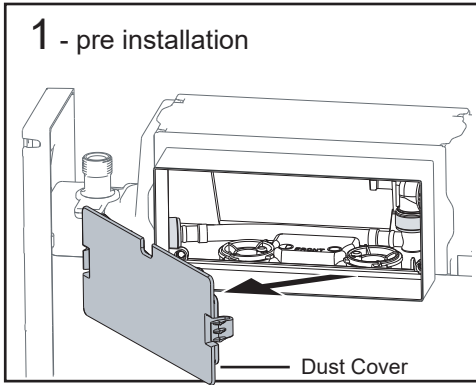

Disconnect Flexible Hose from the Inlet Valve and the Ball Valve.

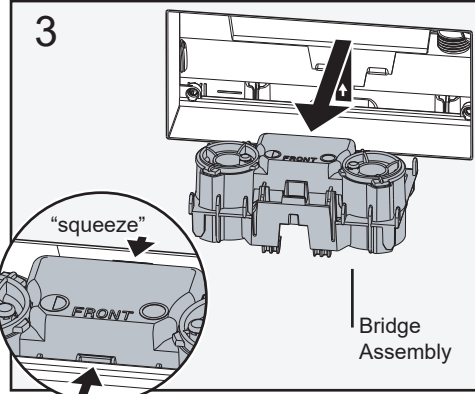

Remove the Bridge Assembly by squeezing tabs front and back to disengage from locking tabs inside the tank.

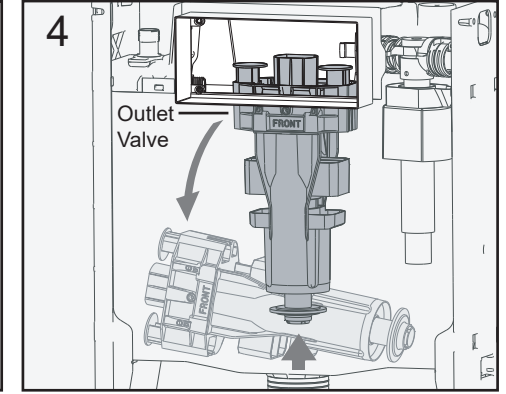

Lift the Outlet Valve to disengage from guide ribs in the base of the tank and lay over on it's side.

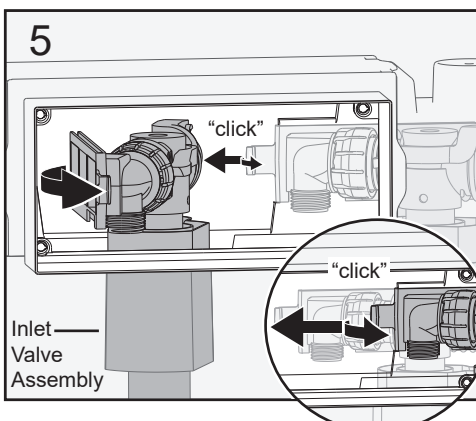

Lift tab and slide the Inlet Valve Bracket to the left.

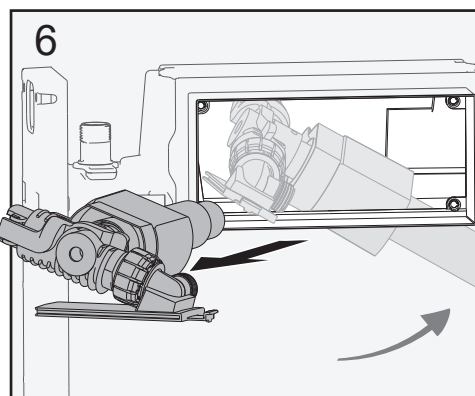

Rotate and remove the Inlet Valve.

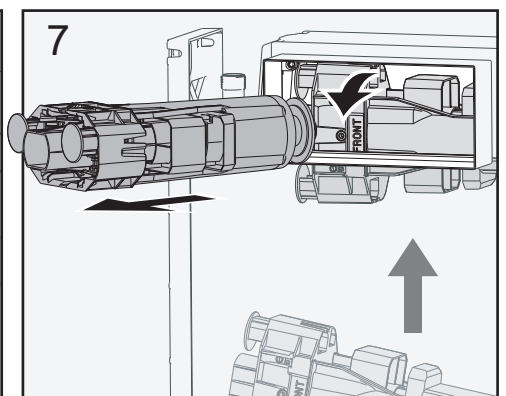

Lift the Outlet Valve from the base of the tank, roll forwards and rotate so the button end comes out first.

NOTE: Reverse procedure to reassemble. 21

The adjustable flush pipe is a new feature for the Invisi II system. If the pan inlet hole is higher than the flush pipe due to floor tiling height variations, the flush pipe can be raised by up to 25mm.

1. After the adjustable flush pipe has been mounted and before the tiler prepares the wall, the blue flush pipe tiling box must slide onto the horizontal flush pipe section as shown in **Fig. 1**.
2. Ensure the horizontal flush pipe is pushed down to the lower position. The tiler can then tile the wall making sure to tile up to the tiling box, as shown in **Fig 2**.
3. Once tiling is complete and the tiles are set, remove the tiling box and discard, as shown in **Fig. 3**.
4. At the time of the pan installation measure the pan inlet hole and check it lines up with the flush pipe. If the flush pipe is too low the horizontal section of the flush pipe can be raised for better alignment to the pan. To adjust the flush pipe insert a large flat edge screwdriver into the gap between the underside of the flush pipe and the noggin and gently lever the underside of the flush pipe to raise to the required height, as shown in **Fig. 4** and **Fig. 5**. Care must be taken not to damage the pipe. If the tiles above the flush pipe restrict the movement then carefully cut a small section of the tile away to allow the flush pipe to move upwards. (*Ensure the pan will cover up the gap created in the tiles when the pan is installed*).

Please Note: The horizontal flush pipe can have a total adjustment range of 25mm.

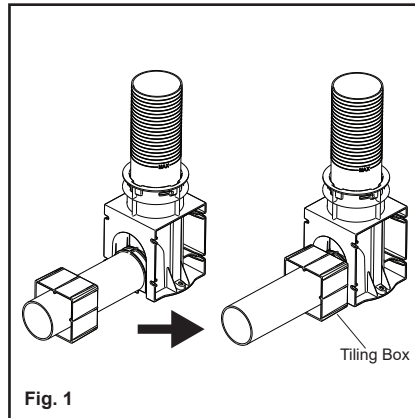

Fig. 1

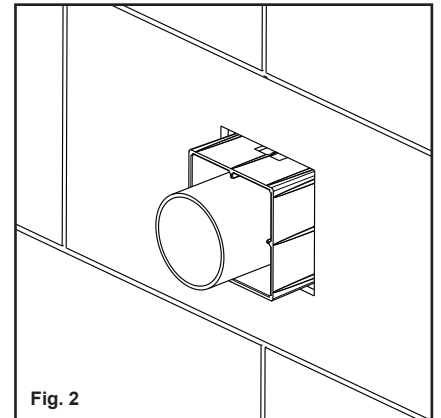

Fig. 2

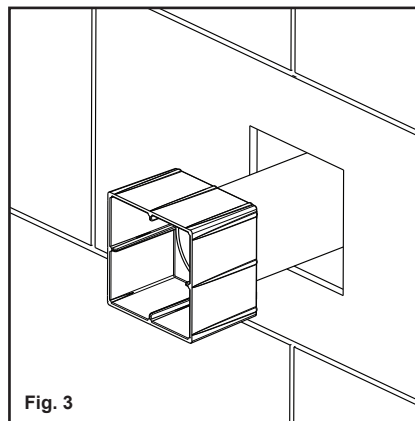

Fig. 3

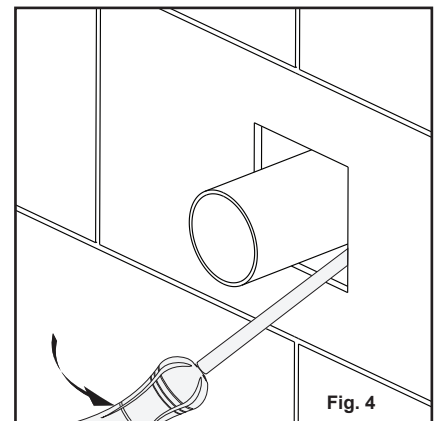

Fig. 4

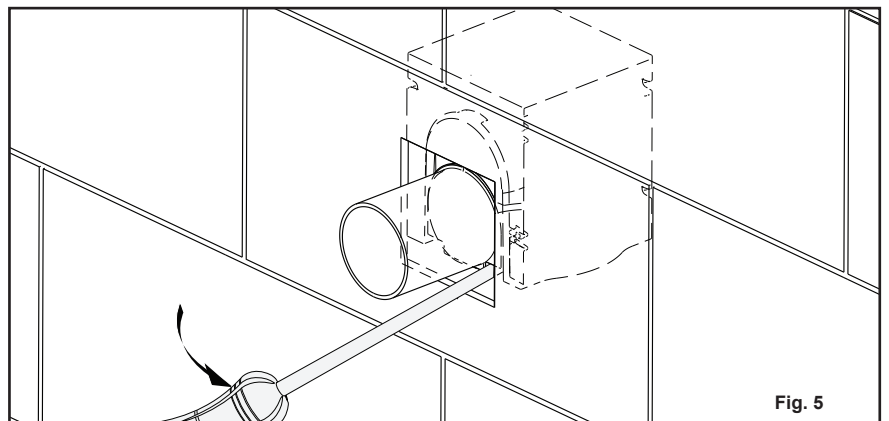

Fig. 5

Servicing Requirements

- Servicing is only required in instances where outlet valve operation is found to be faulty.

Troubleshooting Guide

- If Outlet Valve leaks ► Inspect seal for damage and replace if necessary.
- If short flushing ► Check pneumatic tubes are pushed into the bridge and buttons
- If any other issues arise ► Consult a plumber or Caroma After Sales Service.

Spare Parts Information

- Caroma Invisi II Outlet Valve compatible Spare Part Kits are:
 - 237 172** Containing - **1 x Complete 4.5/3L Outlet Valve**
 - 237 070** Containing - **10 x Diaphragm Seal**
- Refer to - **Maintenance & Spare Parts Instructions**

Maintenance & Spare Parts Instructions

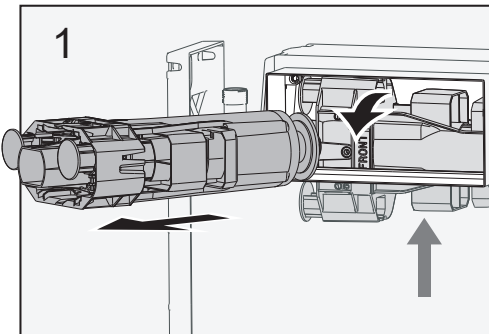

1
Ensure mains water is turned off and remove Outlet Valve from cistern as per the instructions on page 21.

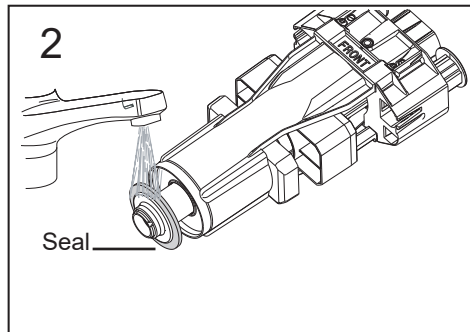

2
Wash seal to remove any dirt and inspect for damage. If necessary remove seal and replace (Spare Part Kit 237 070).

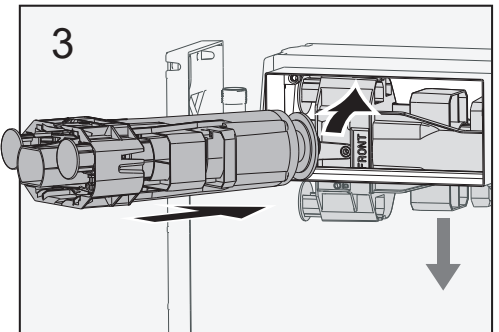

3
Re-assemble complete Outlet Valve and refit into cistern. Turn mains water back on, wait for cistern to fill and test both buttons to ensure they activate the outlet valve.

Servicing Requirements

- Inlet Valve Seal may require periodic cleaning (dependant on water quality) - procedure as defined below.

Troubleshooting Guide

- Inlet Valve is slow to fill OR fails to open ► Ensure tap is open.
- Inlet Valve fails to close ► Clean & inspect seal as described above, replace Cap Assembly & Seal if damaged.
- If any other issues arise ► Consult a plumber or Caroma After Sales Service.

Spare Parts Information

- Caroma Invisi II Inlet Valve compatible Spare Part Kits are:
687 171 Containing - **1 x Complete Unifill Inlet Valve** with bayonet connection
687 049 Containing - **1 x Cap Assembly - 1 x Seal**
Refer to - **Maintenance & Spare Parts Instructions**

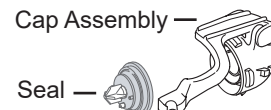

Maintenance & Spare Parts Instructions

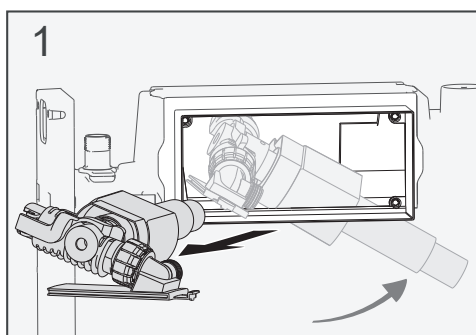

Ensure mains water is turned off and remove Inlet Valve from cistern as per the instructions on page 21.

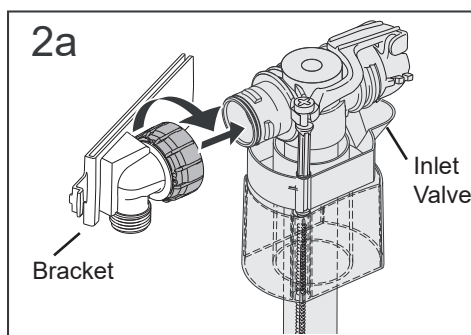

To replace complete Inlet Valve:
Rotate nut anti-clockwise & pull to disconnect it from the Bracket.

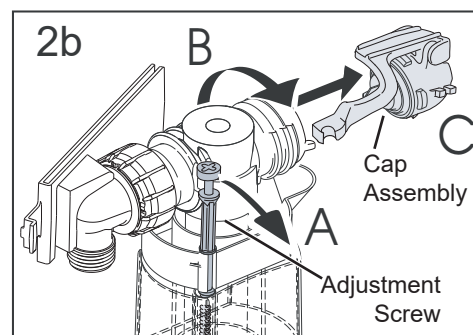

To clean and inspect seal:
Unclip the Adjustment Screw, rotate anti-clockwise & pull to remove cap assembly.

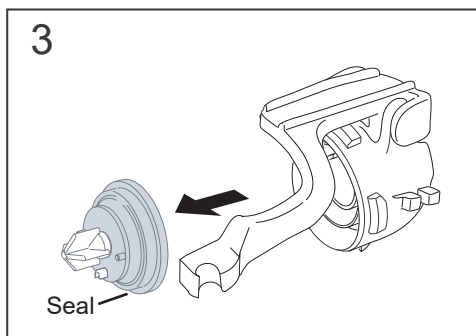

Remove seal from Cap Assembly.

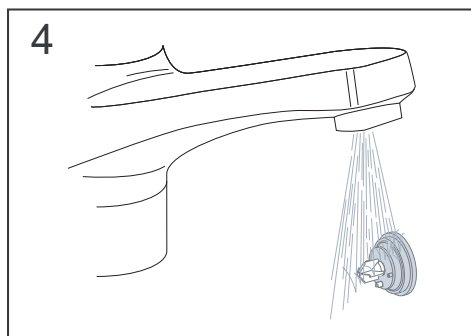

Wash seal to remove any dirt and inspect for damage.

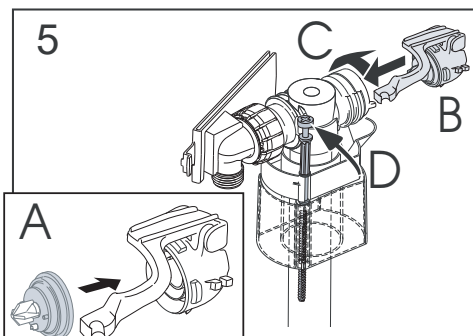

Replace seal onto cap assembly. If necessary replace cap & Seal (Spare Part Kit 687 049). Push & rotate clockwise to re-attach cap assembly, re-clip Adjustment Screw and refit into cistern.

Recommended Water Supply Pressure

Water Supply pressure minimum 30 kPa - Maximum 1000 kPa

Important Notices

Helplines

Australia
New Zealand
USA

131416
09 279 2700
1800 605 4218