

Adheseal

Flooring, Roofing and Decking



UC Leveller - Mapei

A fast hardening levelling / smoothing compound for interior applications suitable for depths of 3mm to 70mm. UC Leveller can be used where resistance to heavy loads and traffic is needed along with an especially smooth surface.

Colour	Size	Code
Grey	20kg	UCLEVELLER



Ultraplan - Mapei

An ultra-fast levelling / smoothing compound for interior applications suitable for depths of 1mm to 15mm. Ultraplan can be used where resistance to heavy loads and traffic is needed along with an especially smooth surface.

Colour	Size	Code
Grey	20kg	ULTRAPLAN

Liquid Flashing Repair Product



Roofers Flash n Patch Liquid Flashing - Adheseal

A highly elastic waterborne hybrid acrylic sealant for applications such as sealing around roof penetrations, seams, inside guttering, damaged roof tiles, punctured roof membrane and around dektites. It has an exceptional resistance to weathering and possesses excellent adhesion to most building materials whilst still maintaining its superb elasticity through both hot and cold climates. Flash n Patch has outstanding adhesion to many common materials including colorbond, zincalume, aluminium, polycarbonate, brick and blockwork, timber, steel and pvc.

Features:

- Excellent adhesion
- UV stable
- Outstanding elasticity
- Water clean up
- Non staining
- Non toxic
- Non hazardous
- Paintable

Colour	Size	Code
Grey	10L	FLASHPATCH/10

Protective and Decorative Coatings

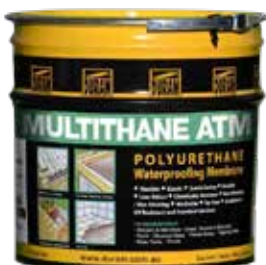

Multithane ATC - Duram

A single pack, aliphatic polyurethane waterproofing top coat which has been formulated as a complimentary top coat for Multithane UV. ATC provides greater UV protection and forms a tough, flexible, seamless, highly UV stable, waterproof coating.

Colour	Size	Code
Grey	15L	MULTITHATC/15



Everflex WPUV - Adheseal

A high performance UV stable waterborne polyurethane / latex waterproofing membrane suitable for internal and external applications. It can be topped, tiled or left exposed and is capable of accommodating expected structural movement.

Applications:

- Exposed concrete and metal roofs
- Balconies, patios and decks to be topped or tiled
- Showers and plant rooms

Colour	Size	Code
Grey	15L	WPUV/15



ViroTuff - Duram

A water based single pack, liquid applied, urethane / polymer, decorative, anti-slip protective coating. ViroTuff provides a UV resistant, tough, durable, semi-flexible trafficable coating with an attractive textured finish. It is suitable for foot and vehicular traffic and is available in a range of colours.

Slip Resistance Rating: Tested to AS/NZ 4586:2004 BPN up to 58.

Appendix A - (Wet Pendulum): Class V After 5000 cycles: BPN up to 44 Class X

Applications:

- Decks, balconies, patios, garages, steps, entertaining and pool surrounds
- Playgrounds, walkways, public toilets and change rooms
- Commercial kitchens and bar areas
- Factory and warehouse floors

Available Colours:

- Black
- Light Grey
- Dark Grey
- Charcoal
- Mossvale
- Clay Pot
- Raw Cotton
- Balsa Stone
- Safety Yellow
- Jarrah
- Heartwood

Colour	Size	Code
Light Grey	4L	VIROTUFFLG/4
Light Grey	15L	VIROTUFFLG/15
Dark Grey	4L	VIROTUFFDG/4
Dark Grey	15L	VIROTUFFDG/15
Safety Yellow	4L	VIROTUFFSY/4
Safety Yellow	15L	VIROTUFFSY/15



Traffic Pave - Aftex

A water-based, slip-resistant UV stable coating with excellent performance against wear and weathering, providing a rejuvenated fresh and safe surface coating that is suitable for internal and external use. Traffic Pave has excellent hot tyre resistance and forms a hardwearing finish.

Available Colours:

- Tan
- Terracotta
- Light Grey
- Slate Grey
- Black
- Daffodil
- Snow
- Emerald
- Sea

Colour	Size	Code
Light Grey	14L	TRAFFPAVELG/14
Slate Grey	14L	TRAFFPAVESG/14



Megapoxy H - Primer

A low viscosity epoxy sealer that is commonly used as a primer coat for Megapoxy protective & decorative floor coatings (including paint flake flooring systems).

Colour	Size	Code
Clear	4L	MPH/4
Clear	20L	MPH/20



Megapoxy 132

Megapoxy 132 is a two-component solvent-less 100% solids epoxy resin. It creates a heavy duty, protective, chemical resistant epoxy coating suitable for decorative floor and wall cladding. Using durable, non - fading pigments will provide floor toppings and wall coatings with pleasing and serviceable appearance and strength. Suitable for garage floors, warehouse or factory floors and can also be used to create a trowelable mortar for screeding floors.

Colour	Size	Code
Clear	15L Kit	MP132CL/15
Clear	30L Kit	MP132CL/30
Grey - N35	15L Kit	MP132GR/15
Grey - N35	30L Kit	MP132GR/30



Megapoxy MC

A two-component epoxy resin that creates a heavy duty, protective and decorative coating for concrete, steel, timber, masonry and more. It has a high resistance to abrasion, impact and a wide range of chemicals. Megapoxy MC can be applied by airless spray equipment, roller or brush and has a long working time (2 hours). For applications requiring fast cure properties Megapoxy MC2 is also available.

Features/Applications:

- Floor & wall coating (decorative & protective)
- Base coat for a decorative paint flake floor coating system
- Provides a hygienic, dust free surface
- Suitable for use in storage tanks that hold chemicals such as foodstuffs and fuel
- Suitable for use in pools
- Resistant to hydrogen sulphide that may be present in pipes and plants used for treatment of sewage

Available Colours*



White	5kg Kit	MPMCWH/5
Grey	5kg Kit	MPMCGR/5
Koala Grey	5kg Kit	MPMCKOGR/5
Dark Grey	5kg Kit	MPMCDKGR/5
Pacific Blue	5kg Kit	MPMCPB/5
Safety Yellow	5kg Kit	MPMCYELL/5
Black	5kg Kit	MPMCBLK/5

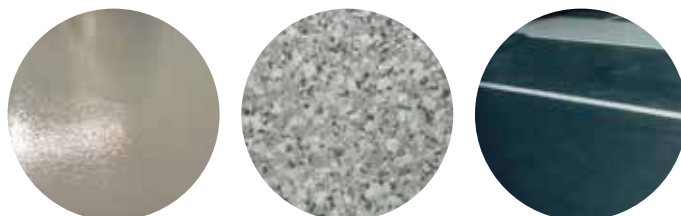

*Colours are not exact. Colours shown are a representation only. Please refer to the actual product sample.

Adheseal

FlexFlake

Step by step installation guide



STEP 1 Prepare

Diamond grind or acid etch the concrete substrate to provide a sufficient key and remove any impurities in the slab such as residues and paint oil grease etc. Previous coatings should be removed and substrate issues such as rising damp problems should be treated before proceeding.



STEP 2 Repair

Repair cracks and any imperfections in the substrate.



STEP 3 Clean

Ensure that the floor surface is clear, dust-free.



STEP 4 Primer

Apply primer coat and allow to fully cure.



STEP 5 Base Coat

Apply selected coloured base coat



STEP 6 Broadcast Flakes

Evenly broadcast FlexFlake paint flakes ensuring the entire floor has dry flake applied. Then allow coloured base coat to fully cure.



STEP 7 Remove Loose Flakes

Use a garden blower or vacuum to remove excess (un-bonded) flake then use a large scraper to remove any loose or sharp flake.



STEP 8 Clean

Again, use a garden blower or vacuum to remove excess (un-bonded) flake.



STEP 9 Seal

Apply a coat of sealer with FlexKote 1PU-C or FlexKote 2AS-C (ensuring there is no pooling). Apply more coats if required.



FlexPrime - Adheseal

A two-part, modified polymer used as a bonding agent and vapour barrier for concrete, timber and steel before the application of Flexkrete 102. This primer promotes adhesion to damp concrete, helps eliminate pinholes caused by outgassing. FlexPrime can be applied by brush, roller or spray. Approximately 8m² per litre coverage.

Size	Code
500ml	FKP/500
2L	FKP/2
10L	FKP/10



Flexkrete 102 - Adheseal

A rapid curing two-part vinyl polymer resin that is used as a base coat for a paint flake floor coating system and also for concrete repair applications. FlexKrete 102 can achieve a 60 minute cure time and cures 3 times harder than concrete. It is essential to use this product in conjunction with FlexPrime primer.

Applications:

- Base coat for paint flake flooring systems
- Base coat for surface reinstatement (broadcast)
- Remedial concrete repairs

Colour	Size	Code
Grey	4kg	FK102GR/4
Grey	20kg	FK102GR/20



FlexTemp - Adheseal

An optional additive used to rapidly accelerate the cure speed of FlexKrete 102 resin in applications that require extremely fast return to service and is also recommended for applications in cooler environments. Using FlexTemp as an accelerant, can achieve full cure in as little as 15 minutes. Adding FlexTemp will allow FlexKrete 102 to be applied in temperatures as low as -18°C.

Size	Code
150ml	FKT/150



FlexKote 1PU - Adheseal

A high performance, single component, UV stabilised, clear, protective and seamless decorative polyurethane floor finish. This coating is a durable, non-yellowing sealer for concrete, masonry, FlexKrete and flake flooring applications.

Features:

- Extremely tough & durable
- Non-yellowing
- Stain resistant
- Wear resistant
- Tyre stain resistant
- Chemical resistant

Colour	Size	Code
Clear / High Gloss	10L	FKOTE1PUCG/10
Clear / High Gloss	20L	FKOTE1PUCG/20



FlexKote 2AS - Adheseal

A rapid drying high performance two-component polyaspartic floor coating. This non-yellowing formula is durable, abrasion resistant and provides a high gloss clear coating suitable for external and internal applications. FlexKote 2AS-C is commonly used when a rapid return to service is required or in low temperature cure environments such as cool rooms.

Features:

- Extremely tough & durable
- Fast return to service
- Low odour & non flammable
- Tyre stain resistant
- Excellent scratch resistance
- Non-yellowing
- Excellent chemical stain resistance

Applications:

- Clear or pigmented seamless floor coating for concrete
- Drive ways, walk ways, factory & shop floors

Colour	Size	Code
Clear / High Gloss	20L	FKOTE2ASCG/20



FlexFlake - Adheseal

Paint flakes that are one part of a multi-part epoxy or FlexKrete decorative flooring system that is widely used in commercial and domestic applications. There are a wide variety of single and blended Flake colours available.

Example Colours



Black Marble XL



Oyster

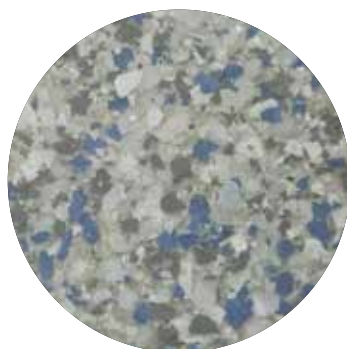

Glacier

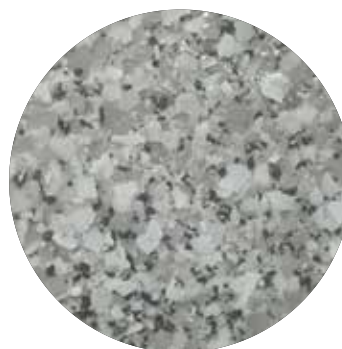

Moonlite

Please contact Adheseal to view the full colour range available.

*Colours are not exact. Colours shown are a representation only. Please refer to the actual product sample.

P E D E S T A L

Buzon



THE ORIGINAL AND AWARD WINNING SCREWJACK PEDESTAL



**Create Raised Timber & Paved Floors On Balconies,
Podiums & Roof Tops**

PASCO

www.buzon.com.au
www.buzon-world.com





Buzon Height Adjustable Pedestal



The award-winning Buzon Pedestal appeals to architects and builders when it comes to the design and construction of raised floors.

It can be used with pavers, timber decking and steel grating to create raised floors on balconies, terraces, green roofs, temporary floors and water features. Capable of accommodating heights from 17mm-1070mm, it can conceal services and offer easy access for maintenance of waterproof membranes.

The Buzon pedestal incorporates a patented slope-correcting device, which compensates for a substrate fall of 0-5%, to provide a perfectly level floor finish. The interchangeable spacer tabs allow for 2mm, 3mm, 4.5mm, 6mm, 8mm and 10mm gaps between pavers, providing positive drainage and making uneven paving lines a thing of the past.

Designed, manufactured and tested in Belgium, the Buzon pedestal is capable of supporting up to 1,000kg. Used on projects all over the world, the applications of the Buzon pedestal are endless.

DPH Series Pedestal Sizing Chart - Adjustable from 17mm to 1070mm

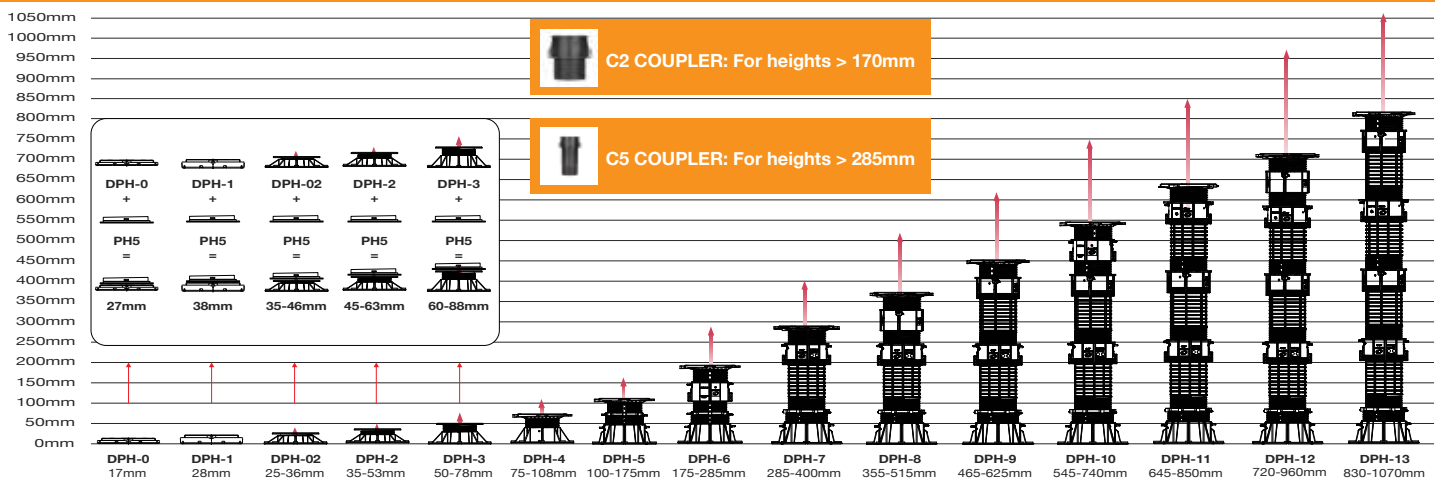

Spacer Tabs

The head can be fitted with spacer tabs, to give the desired opening between pavers for water drainage and ventilation.



Available with tab widths of 2, 4.5, 6, 8 and 10mm

Shims

Made of 1 and 2 mm Reinforced EPDM (Shore 50), for use with marble, granite and stone pavers to act as:

- Anti slip
 - Shock Absorber
- Also compensates for the difference in thickness of the pavers used during the installation



PH5 Slope Corrector

Manufactured from recycled polypropylene, the PH5 slope corrector can compensate for a horizontal slope, from 0 to 5% (slope from 0 to 5cm per meter). For good run-off of rain water, the minimum slope should be 2%.

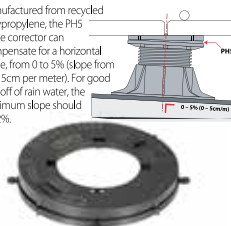

Joist/Batten Holder

Support for all types of joists or battens:

- Timber batten or joists
- Composite Timber battens or joists
- Aluminium/Steel sections

Width of the holder is 65mm with holes on the sides for a mechanical fixing.



Adjustable Joist / Batten Holder

Support for all types of joist or battens:

- Timber batten or joists
- Composite timber battens or joists.
- Aluminium / steel sections

Adjustable from 35 – 90mm with holes on the sides for a mechanical fixing.



FEATURES:

- Designed & manufactured in Belgium
- Made from 5mm thick 80% recycled polypropylene
- 2, 3, 4.5, 6, 8 & 10mm Paver Spacer Tabs
- Adjustable heights from 17mm to 1070mm
- UV stable & chemical resistant
- Provision for mechanical fixing if required
- Inbuilt safety locking mechanism
- Millimetric adjustment

BENEFITS:

- Provides a sustainable solution
- Easy access to waterproofing membrane
- Allows for positive drainage & air ventilation
- Reduces sound transmission & increases temperature insulation
- Ability to conceal services (i.e. plumbing, electrical etc)
- Compensates for 0-5% fall
- Will support up to 1000Kg to a height of 1070mm
- Quick & easy installation
- Reduces weigh loading by eliminating sand & cement mortar beds



All Types of Timber & Composite Decking



Pedestal + Joist/Batten Holder

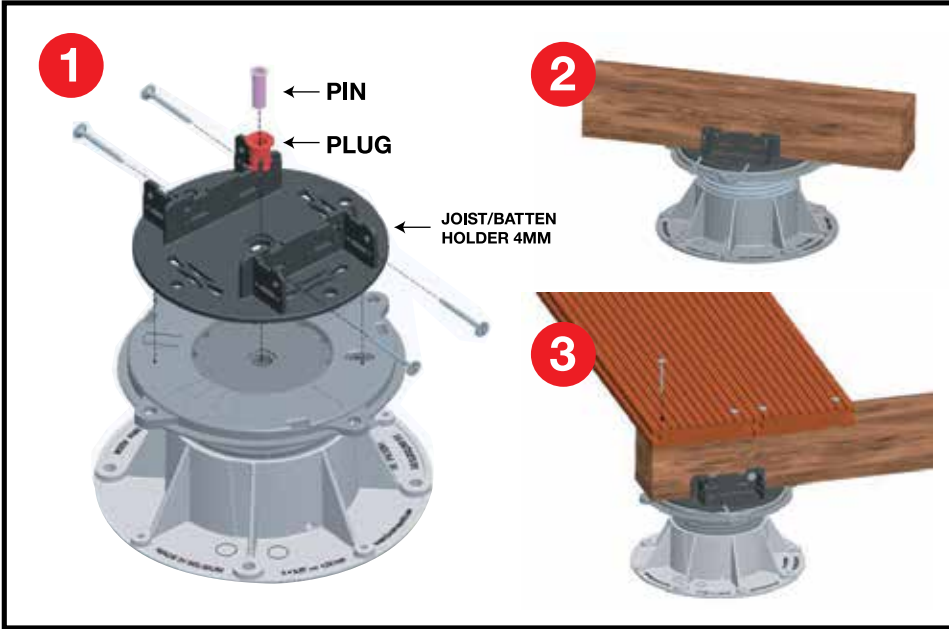



All Types of Pavers & Stone

The Buzon height adjustable pedestal has a unique 0 – 5% slope compensation device, invented and patented by Claude Buzon

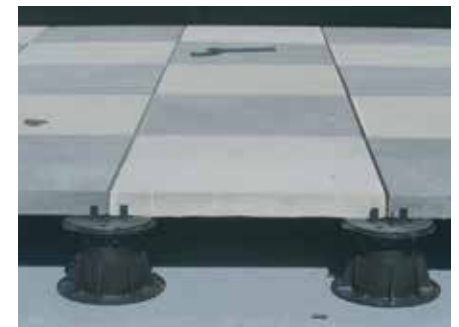

PASCO

Head Office (VIC)
13-15 Brighton St
Richmond VIC 3121
Tel: (03) 9429 9111
Fax: (03) 9429 6111

NSW Distributor
Ausdrain
Suite 10, 2-4 Bells Ave
Cammeray NSW 2062
Tel: (02) 9929 7650
Fax: (02) 9929 7655

WA Distributor
Civil & General Distributors
27 Oxleigh Drive
Malaga, WA 6090
Tel: (08) 9249 4733
Fax: (08) 9209 1220

SA Distributor
P. Hughes Enterprises
15 Saltram Rd
Glenelg, SA 5045
Tel: 0432 418 255
Fax: (08) 8376 3094

QLD Distributor
Adheseal - Brisbane
26 Wolverhampton St
Stafford QLD 4053
Tel: (07) 3356 0000
Fax: (07) 3356 0005

QLD Distributor
Adheseal - Sunshine Coast
2/18 Kessling Ave
Kunda Park QLD 4556
Tel: (07) 5477 0022
Fax: (07) 5477 0020



DPH-0 - Buzon (17mm Non Adjustable Pedestal)

The DPH-0 is a 17mm fixed height pedestal and is the lowest fixed pedestal in the DPH range. There is a selection of Buzon accessories available to support raised floors in outdoor and indoor applications. Adding the optional Buzon PH5 slope corrector will add 9mm to the pedestal height.

Size	Code
17mm	BUZDPH/0



DPH-1 - Buzon (28mm Non Adjustable Pedestal)

The DPH-1 is a 28mm fixed height pedestal and is the highest fixed pedestal in the DPH range. There is a selection of Buzon accessories available to support raised floors in outdoor and indoor applications. Adding the optional Buzon PH5 slope corrector will add 9mm to the pedestal height.

Size	Code
28mm	BUZDPH/1



DPH-02 - Buzon (25-36mm Screwjack Pedestal)

The DPH-02 pedestal has an adjustable height range from 25 to 36mm. There is a selection of Buzon accessories available to support raised floors in outdoor and indoor applications. Adding the optional Buzon PH5 slope corrector will add 9mm to the pedestal height.

Size	Code
25-36mm	BUZDPH/02



DPH-2 - Buzon (35-53mm Screwjack Pedestal)

The DPH-2 pedestal has an adjustable height range from 35 to 53mm. There is a selection of Buzon accessories available to support raised floors in outdoor and indoor applications. Adding the optional Buzon PH5 slope corrector will add 9mm to the pedestal height.

Size	Code
35-53mm	BUZDPH/2



DPH-3 - Buzon (50-78mm Screwjack Pedestal)

The DPH-3 pedestal has an adjustable height range from 50 to 78mm. There is a selection of Buzon accessories available to support raised floors in outdoor and indoor applications. Adding the optional Buzon PH5 slope corrector will add 9mm to the pedestal height.

Size	Code
50-78mm	BUZDPH/3



DPH-4 - Buzon (75-108mm Screwjack Pedestal)

The DPH-4 pedestal has an adjustable height range from 75 to 108mm with an integrated slope corrector that compensates for a horizontal slope from 0 - 5% or 0 - 5cm per metre. There is a selection of Buzon accessories available to support raised floors in outdoor and indoor applications.

Size	Code
75-108mm	BUZDPH/4



DPH-5 - Buzon (100-175mm Screwjack Pedestal)

The DPH-5 pedestal has an adjustable height range from 100-175mm with an integrated slope corrector that compensates for a horizontal slope from 0 - 5% or 0 - 5cm per metre. There is a selection of Buzon accessories available to support raised floors in outdoor and indoor applications. Using Buzon couplers can increase the height for installations up to 1070mm.

Size	Code
100-175mm Screwed	BUZDPH/5
100-175mm Un-Screwed	BUZDPH/5UNS



Coupler - Buzon

Couplers are added to the DPH-5 pedestal to extend the height range of the pedestal. Using Buzon couplers can increase the height for installations up to 1070mm.

Size	Code
C2	For heights 170mm BUZC/2
C5	For heights 285mm BUZC/5



Shims - Buzon

For use with marble, granite and stone pavers. The shims act as a shock absorber and compensates for the difference in thickness of pavers during the installation.

Size	Code
1mm	BUZSHIM/1
2mm	BUZSHIM/2



Joist/Batten Holder - Buzon

A joist or batten holder that clips to the top of the DPH Pedestal series to support all types of battens and will accommodate up to a 65mm wide joist with holes on the side for mechanical fixing. The Joist/Batten Holder also requires a locking pin and plug and will increase the pedestal height by 4mm.

Size	Code
Up to 65mm	BUZJBH



Adjustable Joist / Batten Holder Support - Buzon

An adjustable joist or batten holder that clips to the top of the DPH Pedestal series to support all types of joists or battens. It has an adjustable width from 35 - 90mm and has holes on the sides for mechanical fixing. The Adjustable Joist/Batten Holder also requires a locking pin and plug and will increase the pedestal height by 10mm.

Size	Code
35-90mm	BUZAJBH



PH5 Slope Corrector - Buzon

The slope corrector adjusts the angle of the head to compensate for a horizontal slope from 0 - 5% or 0 - 5cm per metre, therefore allowing the head of the pedestal and in turn the finished surface to be perfectly level. The PH5 Slope Corrector can be used with DPH0, DPH1, DPH02, DPH2 & DPH3. Using this product will increase the pedestal height by 9mm.

Size	Code
-	BUZPH/5



Spacer Tabs - Buzon

The spacer tabs are designed for Buzon tile and paver installations. They clip to the top of the chosen pedestals to achieve the desired opening between pavers for water drainage and ventilation. Plug is not required for Spacer Tabs.

Size	Code
2mm	BUZST/2
3mm	BUZST/3
4.5mm	BUZST/4
6mm	BUZST/6
8mm	BUZST/8
10mm	BUZST/10



Plug - Buzon

First part of a two-part locking mechanism to secure the Buzon Joist Batten Holder to the DPH pedestals. The plug size required will depend on the pedestal and accessory combination used.

Medium Plug:

- For all DPH pedestals except when combined with PH5 Slope Corrector or Buzon Adjustable Joist Holders

Long Plug:

- Suitable for DPH-0 to DPH-3 pedestals in combination with using a PH5 Slope Corrector
- Suitable for all DPH pedestal sizes when using the Buzon Adjustable Batten Holder

Size	Code
Medium	BUZPLUGM
Long	BUZPLUGL



Pin - Buzon

Second part of a two part locking mechanism to secure the Buzon accessories to the DPH pedestals. The pin size required will depend on the pedestal used.

Size	Code
Long (for all DPH pedestal except DPH-0)	BUZPINL



*The Original
and The Best*



RAIMONDI
Professional Tiling Tools.
Exclusively Distributed by B.A.T. Trims



1800 BAT TRIMS (1800 228 874)
www.battrims.com



RLS Starter Kit

Raimondi Levelling System (RLS) ensures precise levelling of tiles and assists to speed up the tile setting process. RLS is strongly recommended when installing flexible, large format, heavy or low-thickness tiles. Kit includes: floor pliers, 100 small base clips and 100 wedges.

Size	Code
RLS Starter Kit	RLSSTART



RLS Large Base Clips

Raimondi Levelling System large base clips. Minimum joint width 1.5mm. Tile thickness 12 - 20mm.

Size	Code
200 Pieces	RLSCLIPLG/200
400 Pieces	RLSCLIPLG/400
1500 Pieces	RLSCLIPLG/1500



RLS Small Base Clips

Raimondi Levelling System small base clips. Minimum joint width 1.5mm. Tile thickness 3 - 12mm.

Size	Code
100 Pieces	RLSCLIPSM/100
250 Pieces	RLSCLIPSM/250
500 Pieces	RLSCLIPSM/500



RLS Wedges

Raimondi Levelling System Wedges. Suits both small & large base clips. RLS wedges are reusable.

Size	Code
100 Pieces	RLSWEDGE/100
250 Pieces	RLSWEDGE/250
500 Pieces	RLSWEDGE/500



RLS Adjustable Traction Pliers

Raimondi Levelling System adjustable floor or wall pliers.

Size	Code
RLS Floor Pliers	RLSPLIERFLOOR
RLS Wall Pliers	RLSPLIERWALL



RLS Replacement Traction Plier Protective Cap

Raimondi Levelling System replacement protective cap for floor and wall adjustable traction pliers.

Size	Code
-	RLSPLIERCAP